



US 20020040880A1

(19) **United States**

(12) **Patent Application Publication**  
**Vasudeva**

(10) **Pub. No.: US 2002/0040880 A1**

(43) **Pub. Date: Apr. 11, 2002**

(54) **DROP-BIN CONTAINERS AND HOLDERS FOR SAME**

(76) Inventor: **Kailash C. Vasudeva, Waterloo (CA)**

Correspondence Address:  
**BORDEN LADNER GERVAIS, LLP**  
**1000 - 60 QUEEN STREET**  
**OTTAWA, ON K1P 5Y7 (CA)**

(21) Appl. No.: **09/982,856**

(22) Filed: **Oct. 22, 2001**

**Related U.S. Application Data**

(63) Continuation-in-part of application No. 09/422,964, filed on Oct. 22, 1999, now patented.

**Publication Classification**

(51) **Int. Cl.<sup>7</sup> ..... A47B 81/00**

(52) **U.S. Cl. .... 211/99; 312/271**

(57) **ABSTRACT**

An organizer is provided, having a holder and at least one container unit, the at least one container unit comprising a housing having opposing side walls, and a plurality of bins mounted between the side walls for rotation between closed and open positions, such that in the closed position, outer faces of the bins are generally coplanar, and in the open position, the outer faces each angle outwardly from the

housing, thereby providing access into the bins, the bins being connected together for movement in unison, the outer faces occupying substantially all of a front portion of the housing. The holder has at least upper and lower elements, the at least one container unit being securable between the upper and lower elements. Each container unit has at least one tab at the bottom thereof, to insert into a corresponding slot in one of the upper and lower elements, and at least one catch to engage a corresponding means in the other of the upper and lower elements. The organizer can be used in combination with another holder, connected thereto. The multiple holders can be hinged together, connected back to back, or connected side to side. The holder advantageously provides a common vertical center wall, with the container units being securable to either side thereof by any suitable means. The housing has a tab extending upwardly from an upper surface thereof, the tab having an opening for hanging the at least one container unit. The tab is either foldable against the upper surface or removable from the housing, so as not to interfere with the connection of the at least one container unit with the holder. In one embodiment, a number of container units are attachable to the holder, in any of a multitude of locations, and the pivoting of the bins is actuated via pinion wheels arranged on each bin, each pinion wheel being engaged in contact with a slidable rack, so that when the rack is manipulated by a user to slide up or down, the rack causes the pinion wheel to rotate and thus the bin is caused to pivot. The racks are connected via at least one cross-beam, so that the manipulation of one rack causes the other racks to perform the same movement as the one rack.

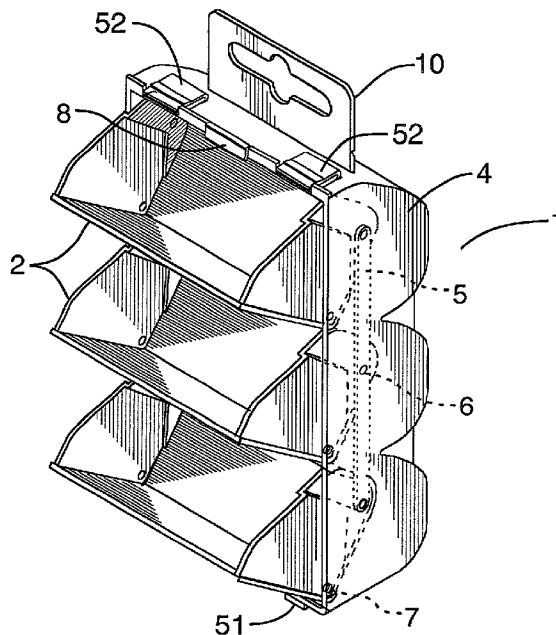

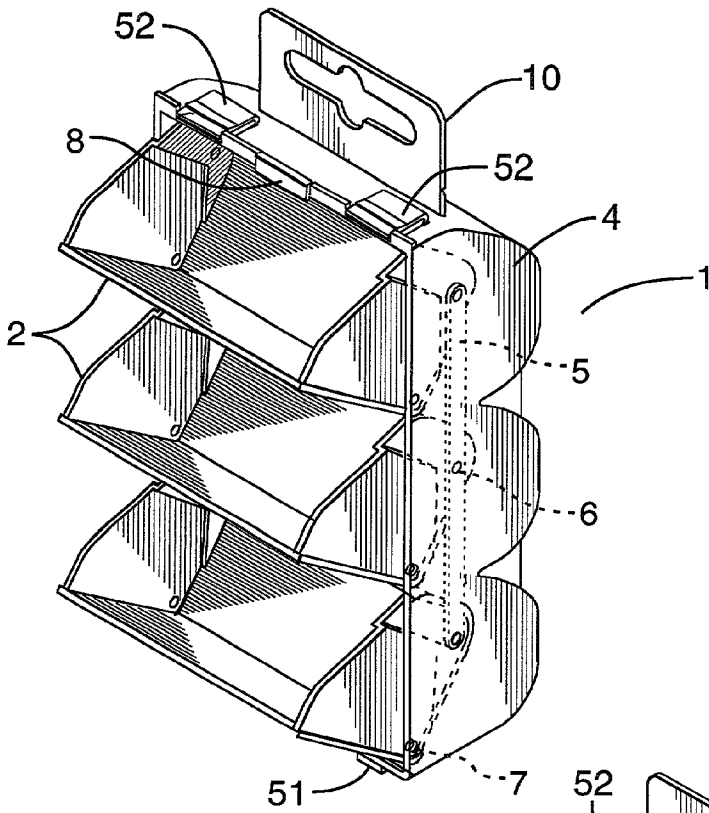

FIG. 1

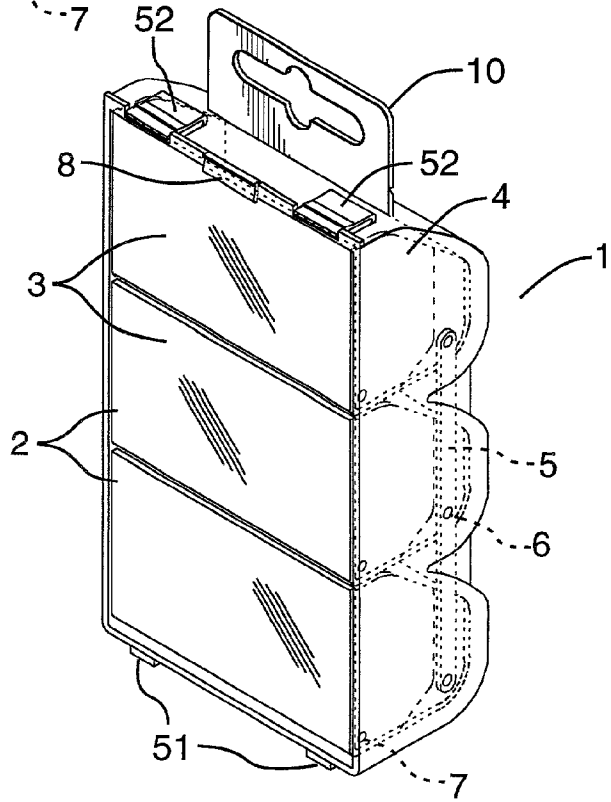

FIG. 2

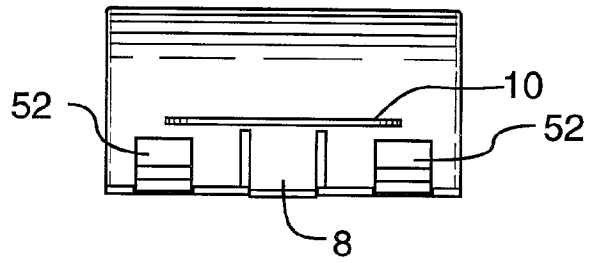

FIG. 3

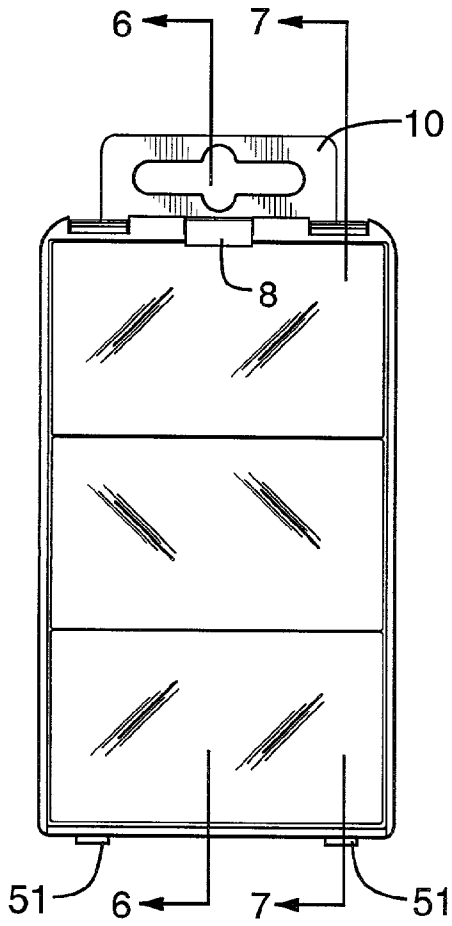

FIG. 4

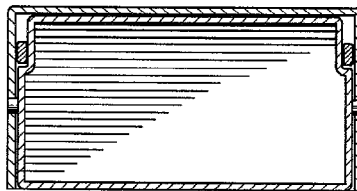

FIG. 5

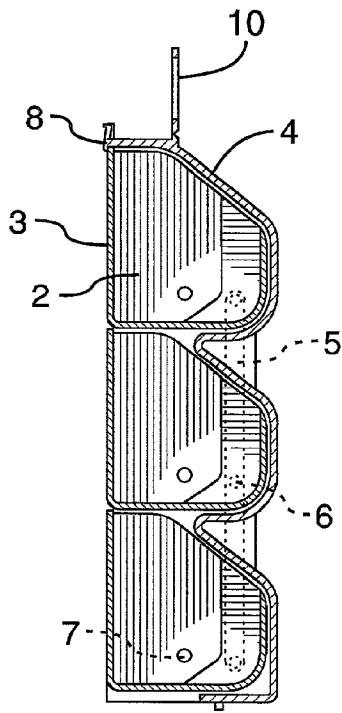

FIG. 6

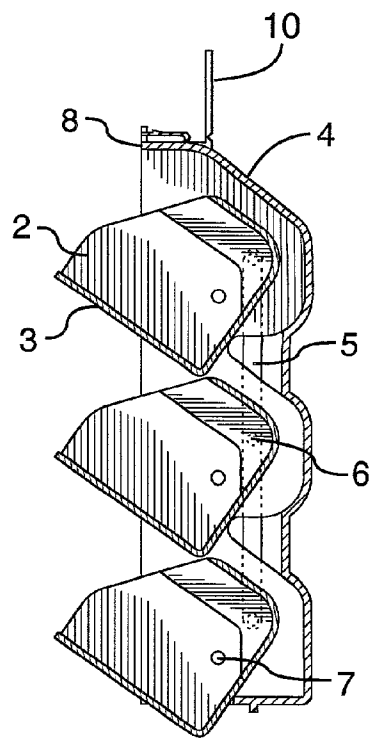

FIG. 7

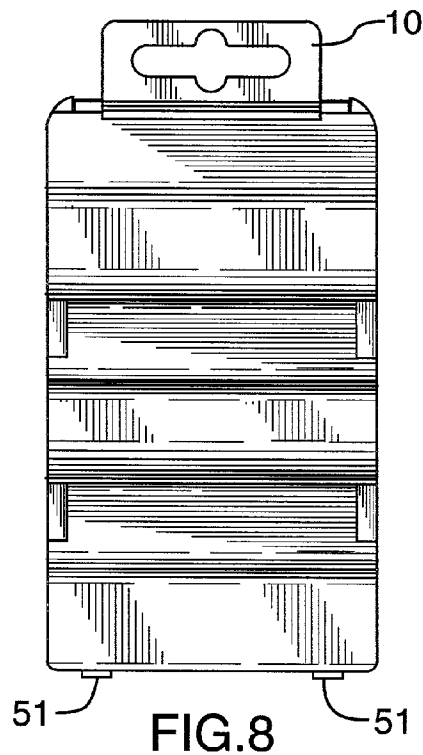

FIG. 8

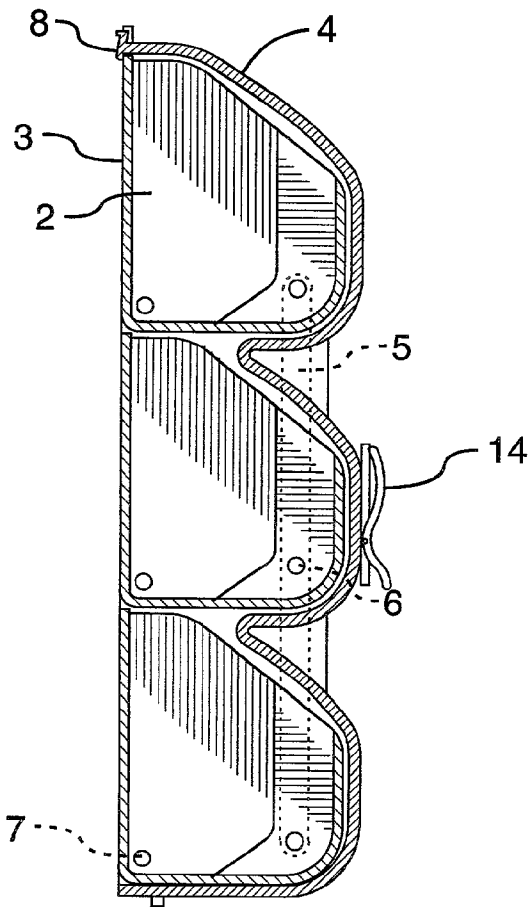

FIG. 10

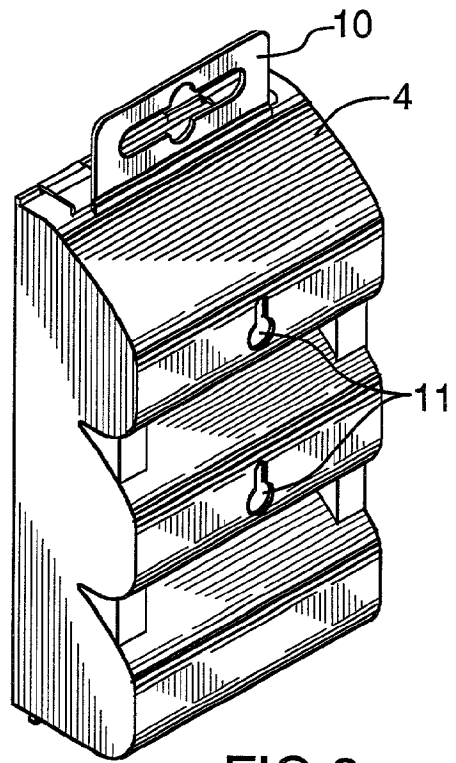

FIG. 9

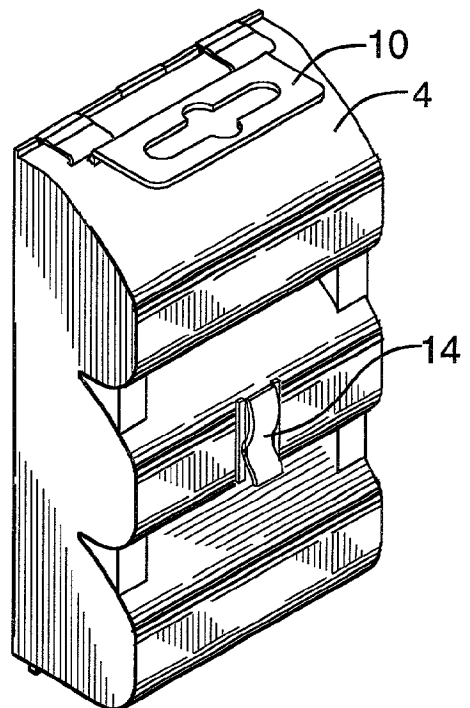

FIG. 11

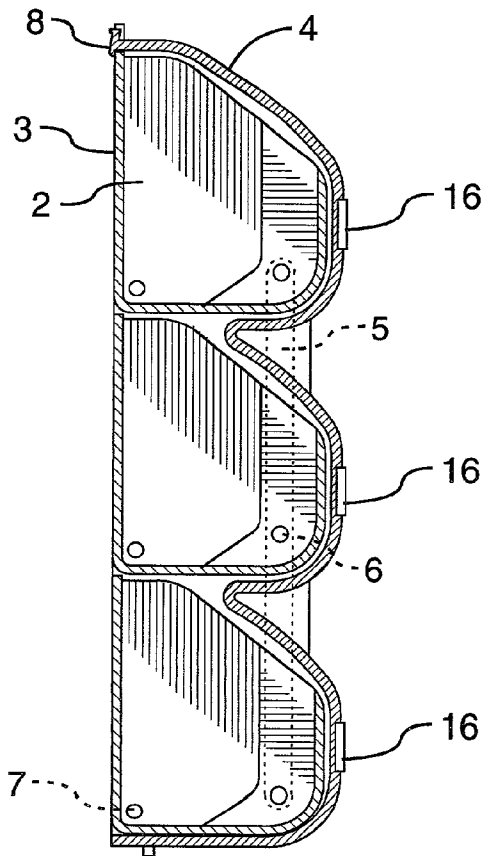

FIG. 12

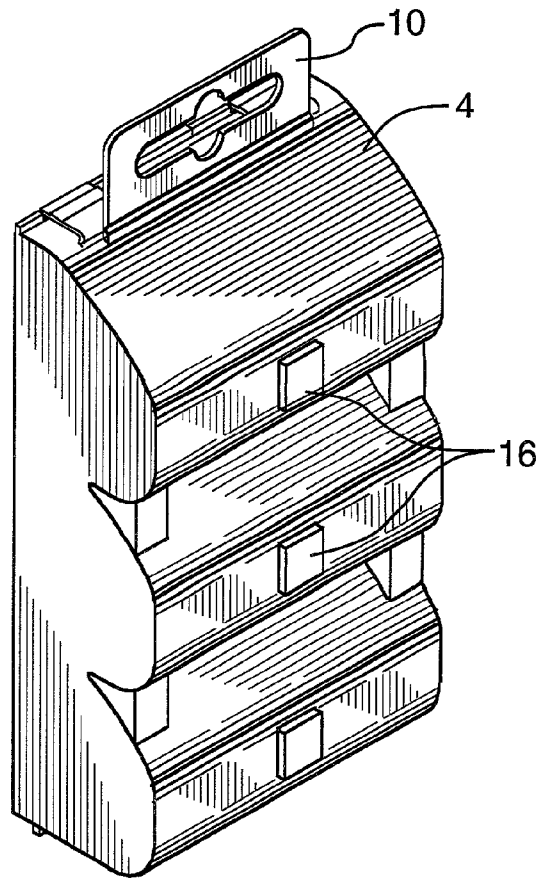

FIG. 13

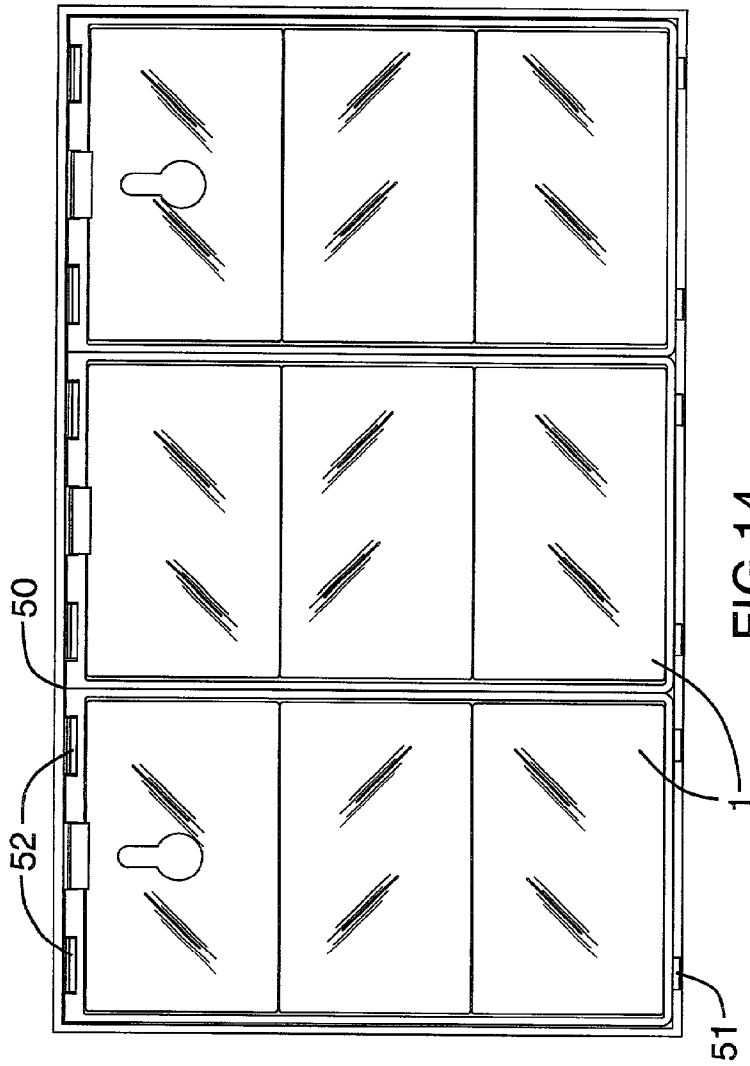

FIG. 14

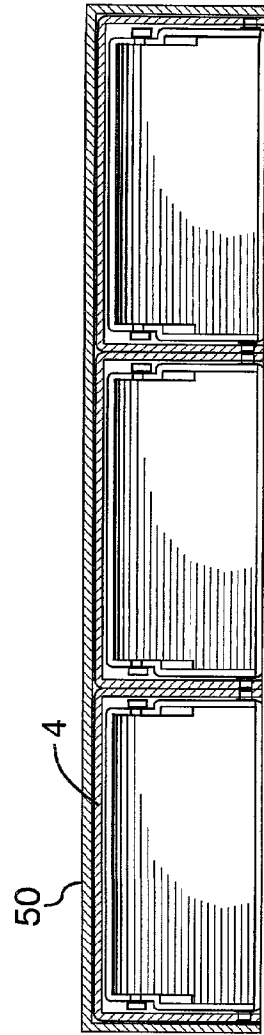

FIG. 15

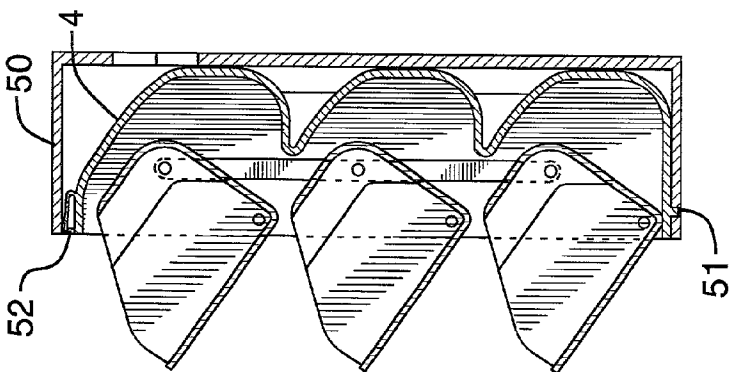

FIG. 16

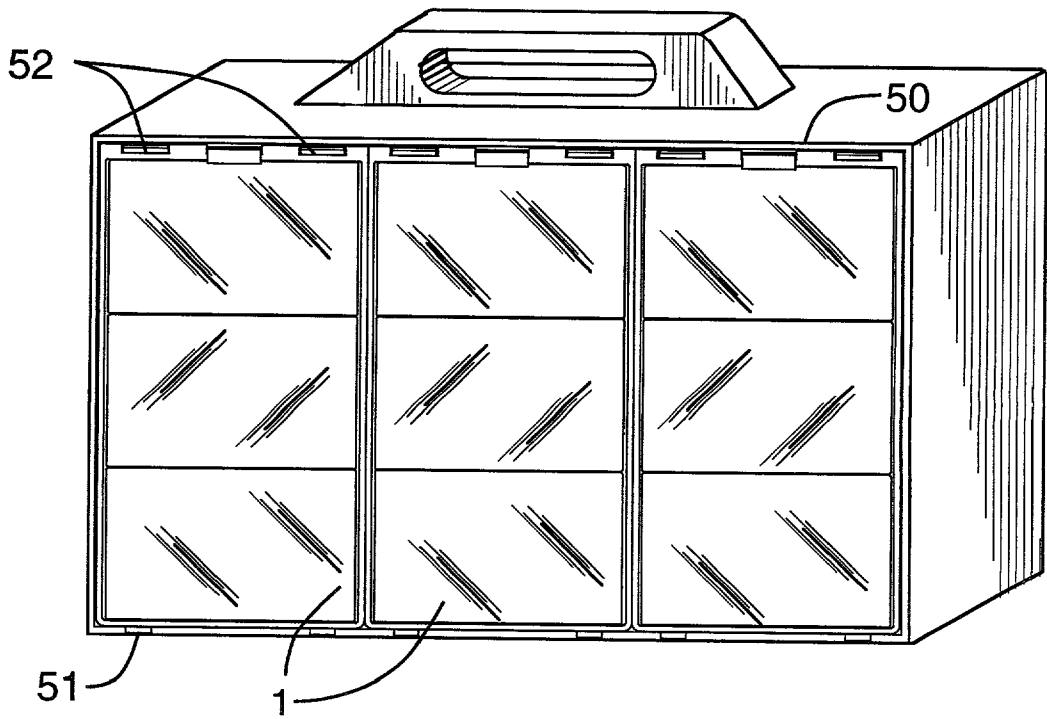
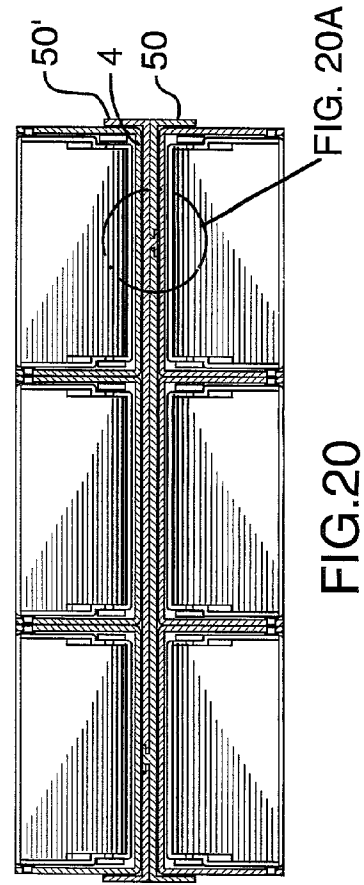
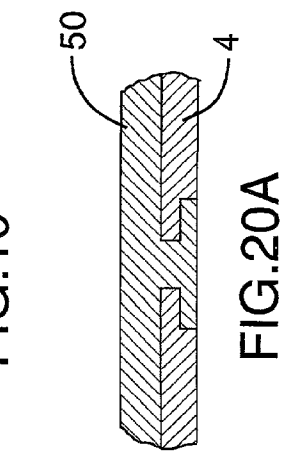
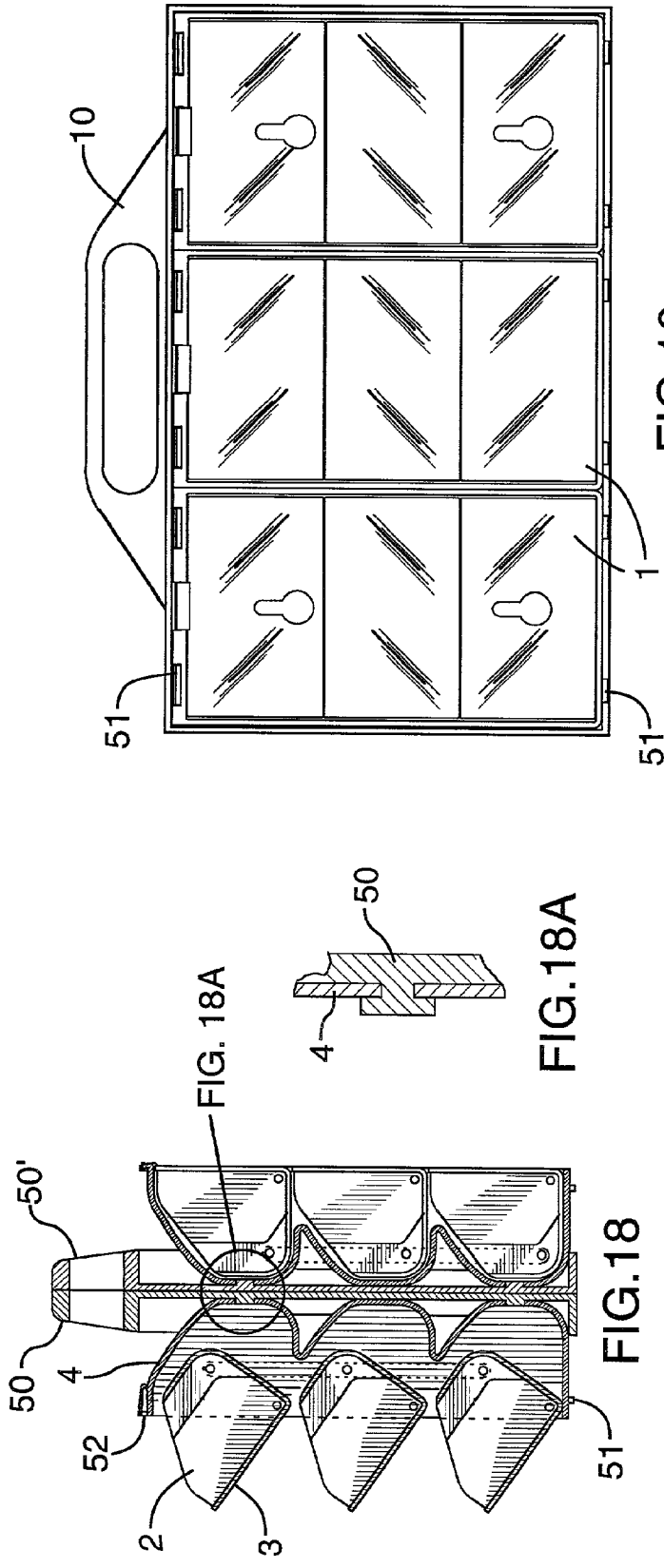

FIG.17





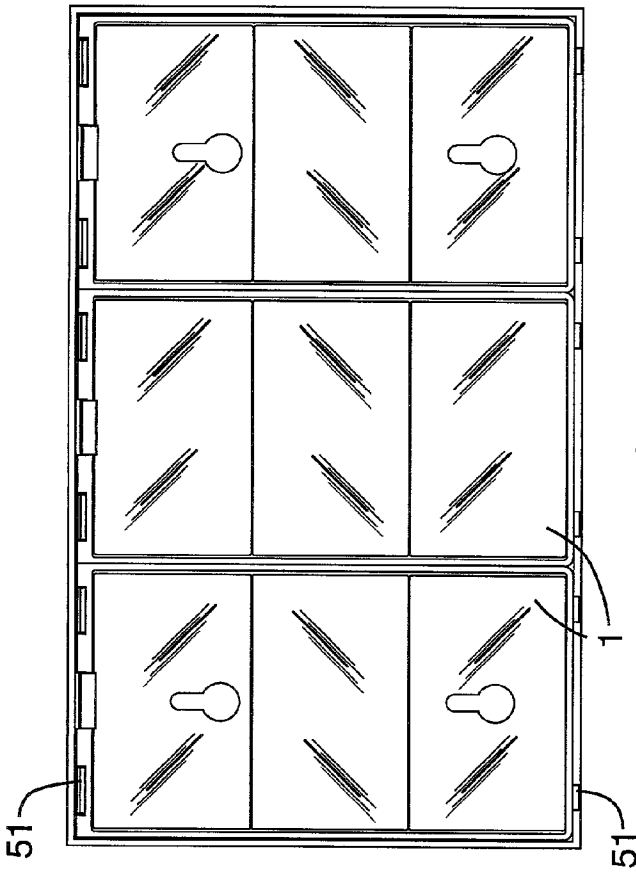

FIG. 22

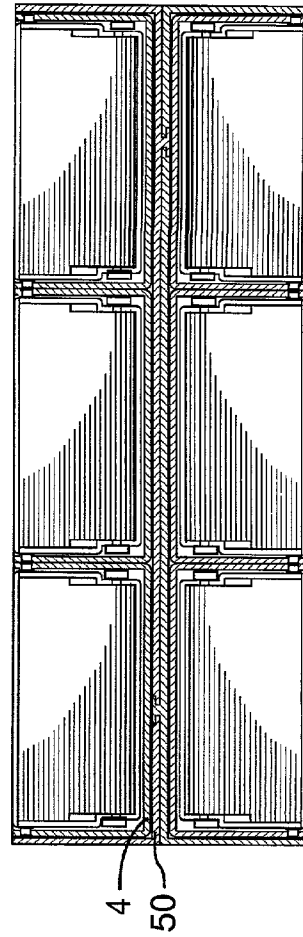

FIG. 23

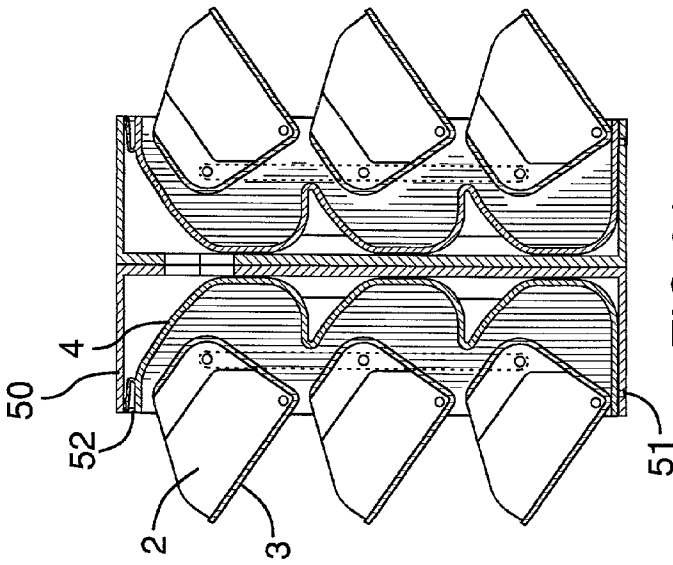

FIG. 21

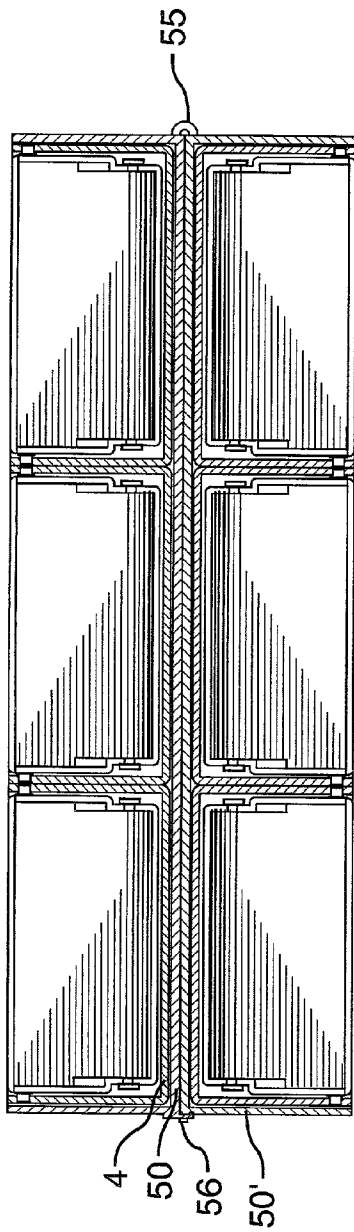

FIG. 24

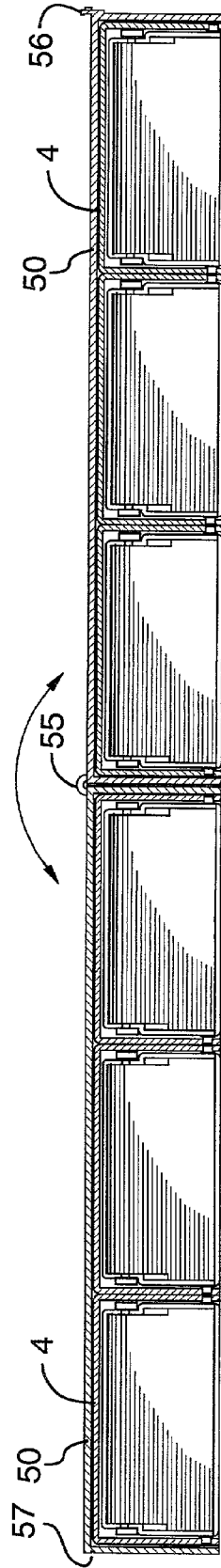

FIG. 25

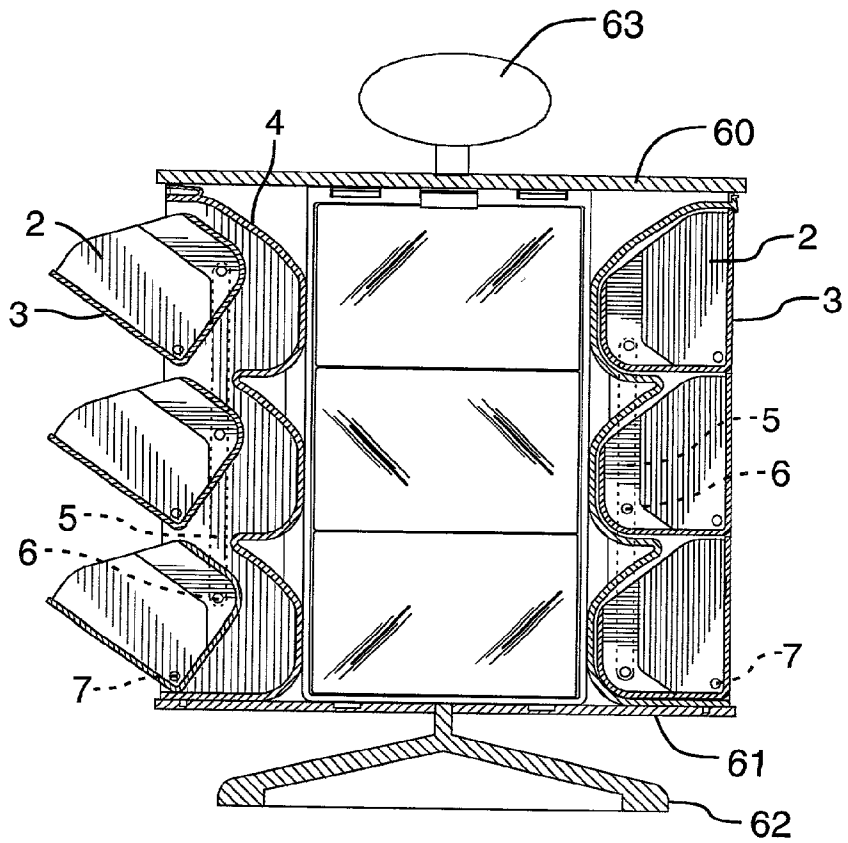

FIG. 26

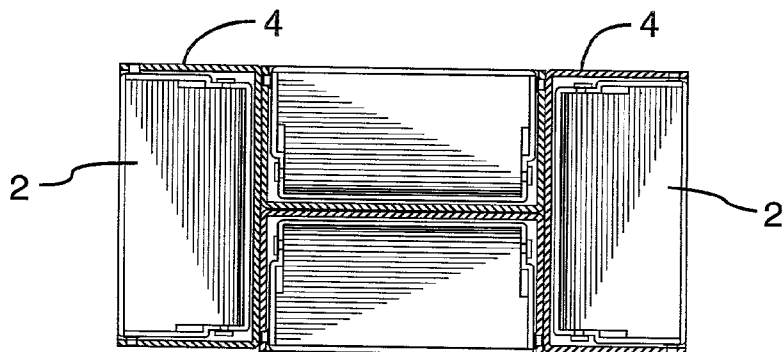

FIG. 27

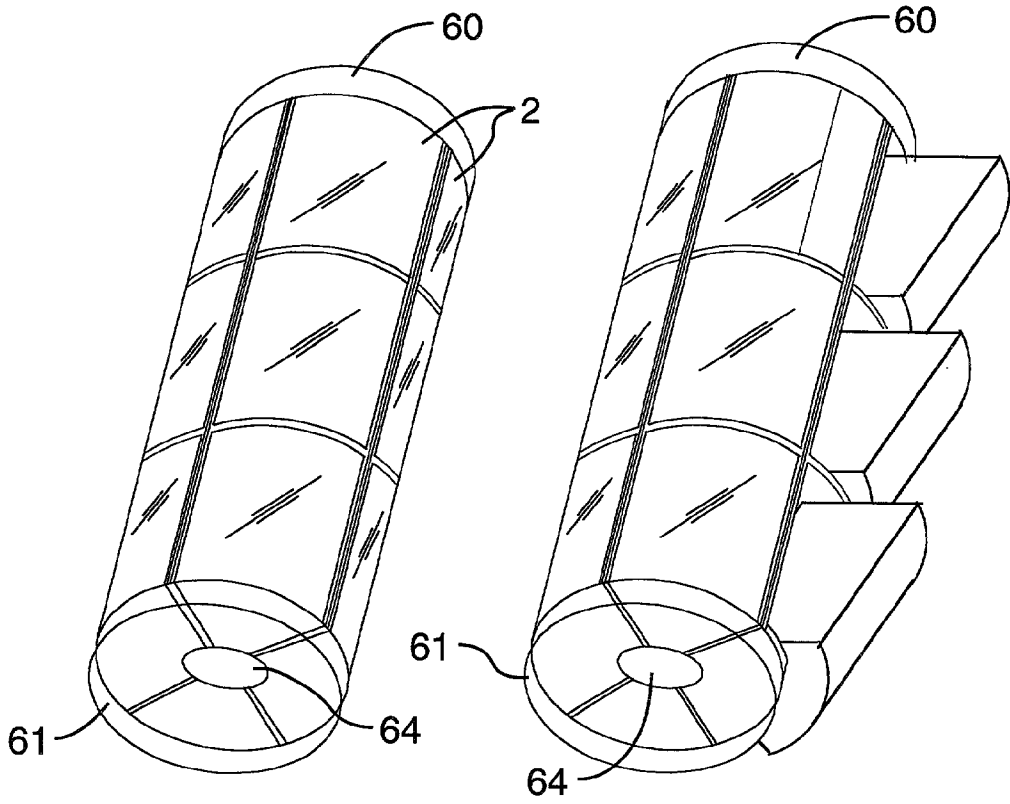

FIG.28

FIG.29

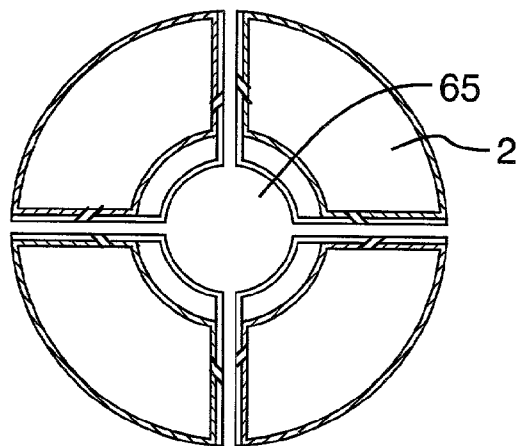

FIG.30

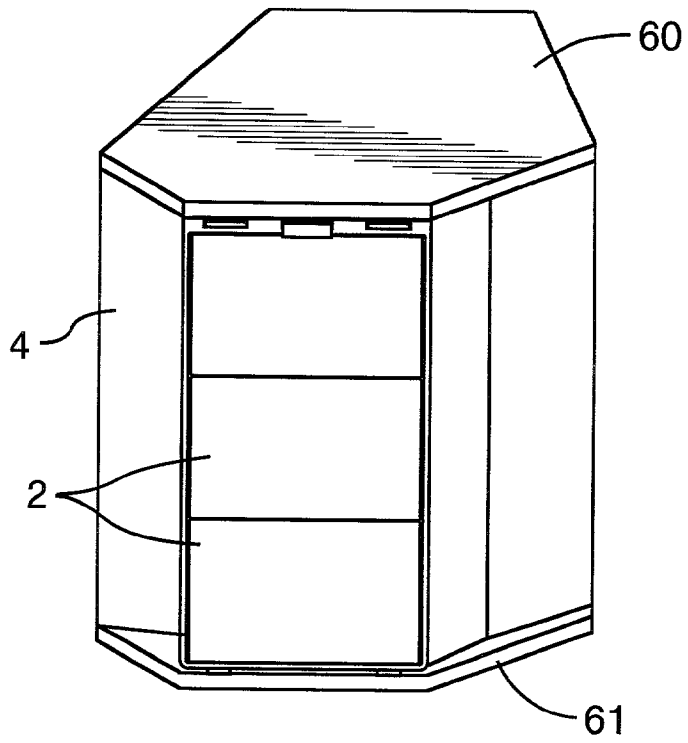

FIG. 31

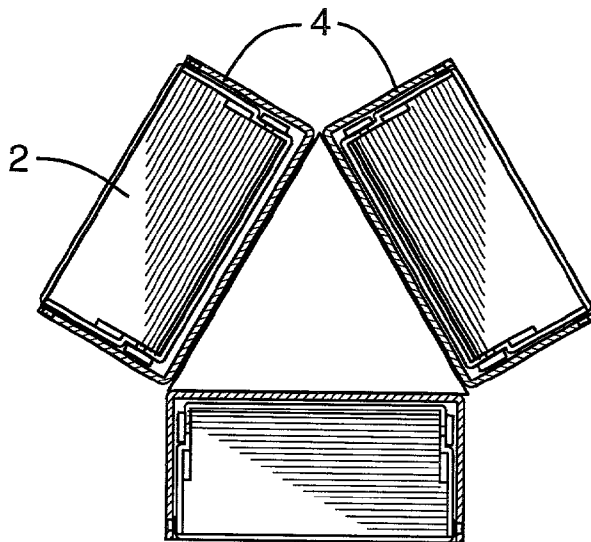

FIG. 32

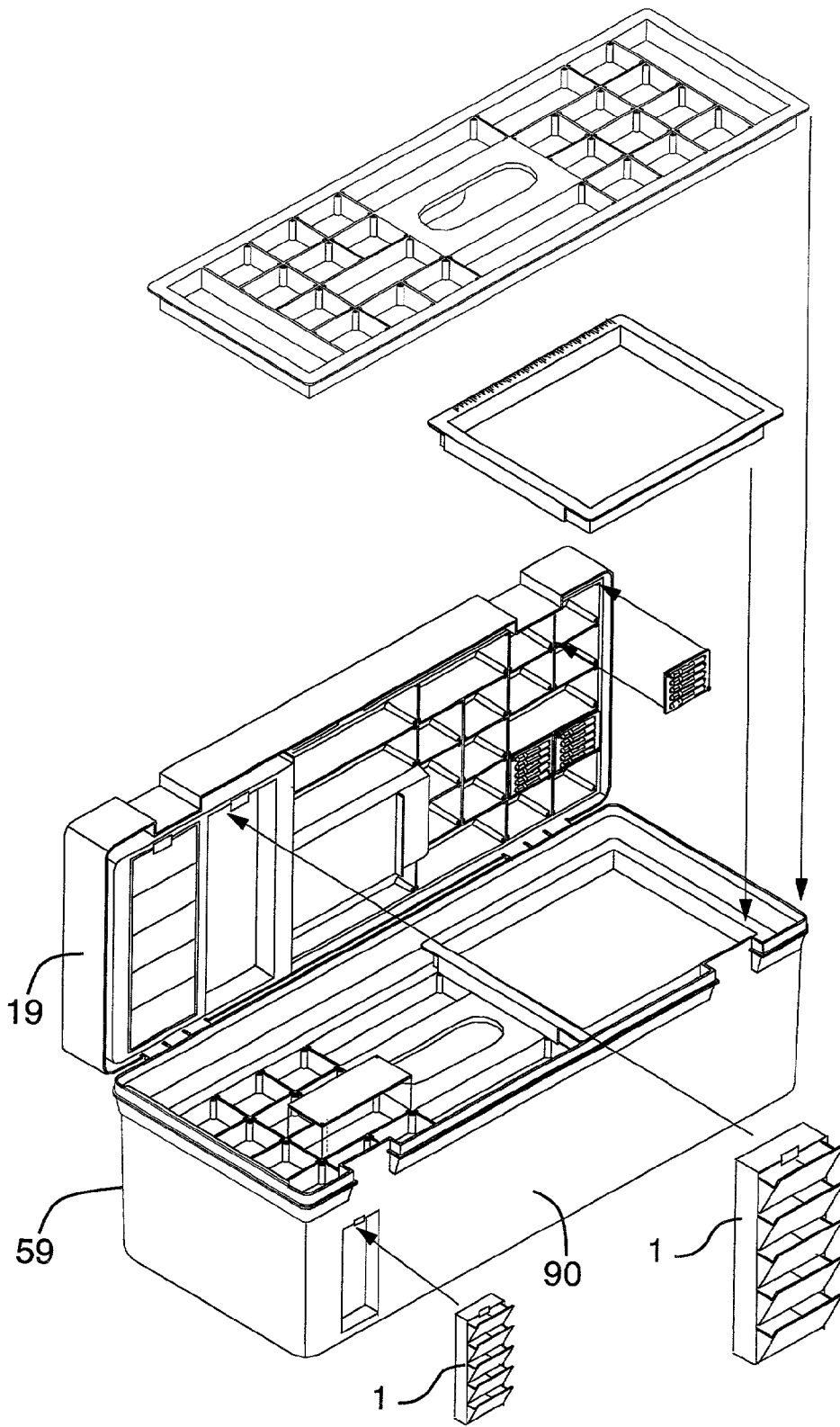

FIG.33

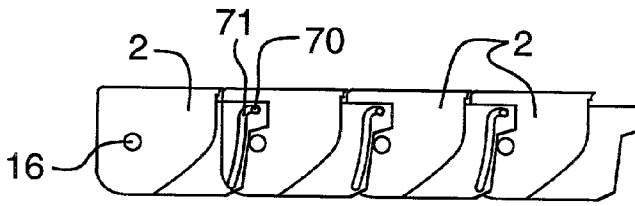

FIG. 34

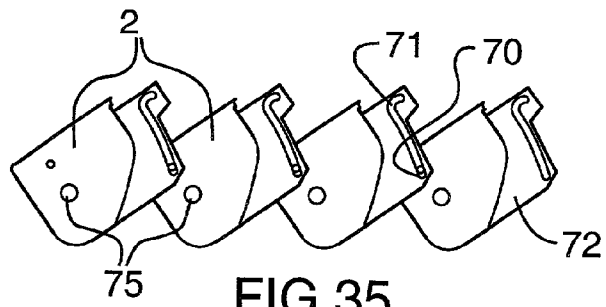

FIG. 35

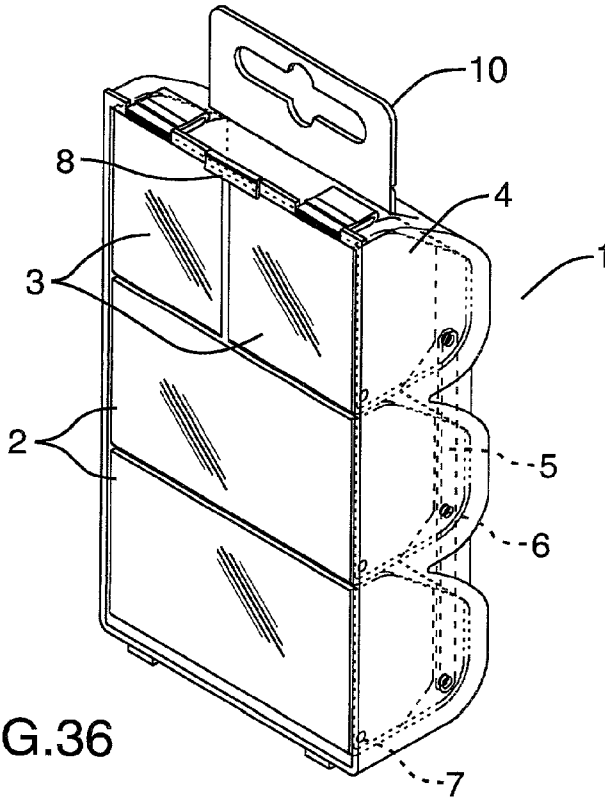

FIG. 36



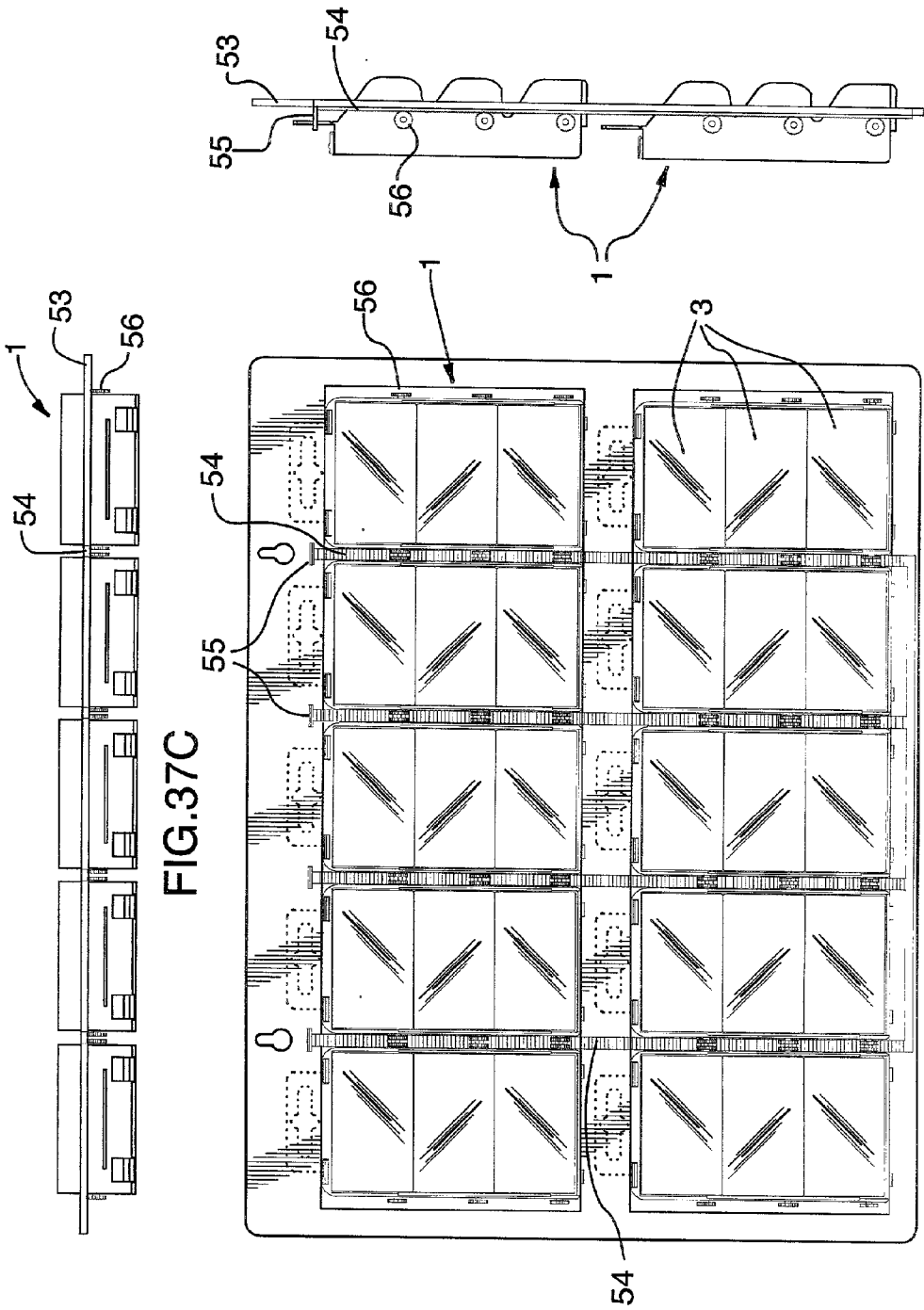

FIG.37C

FIG.37B

FIG.37A

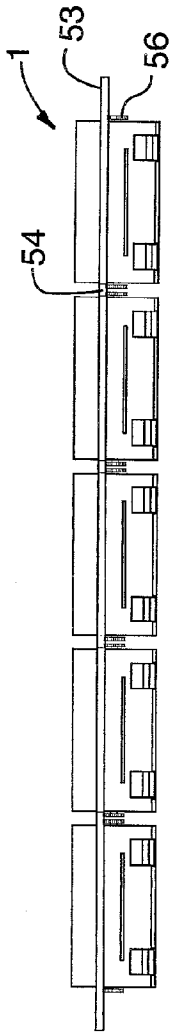

FIG. 37F

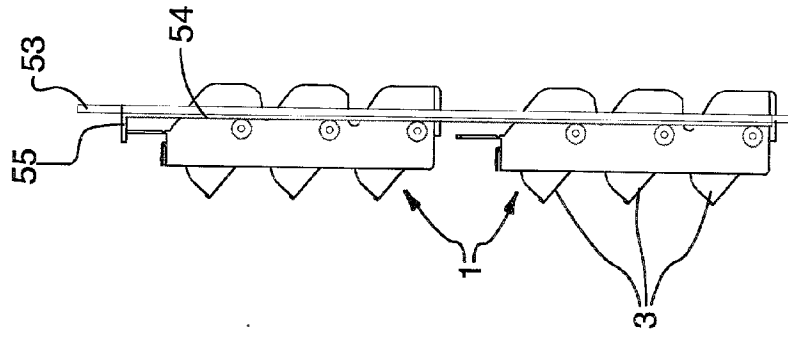

FIG. 37E

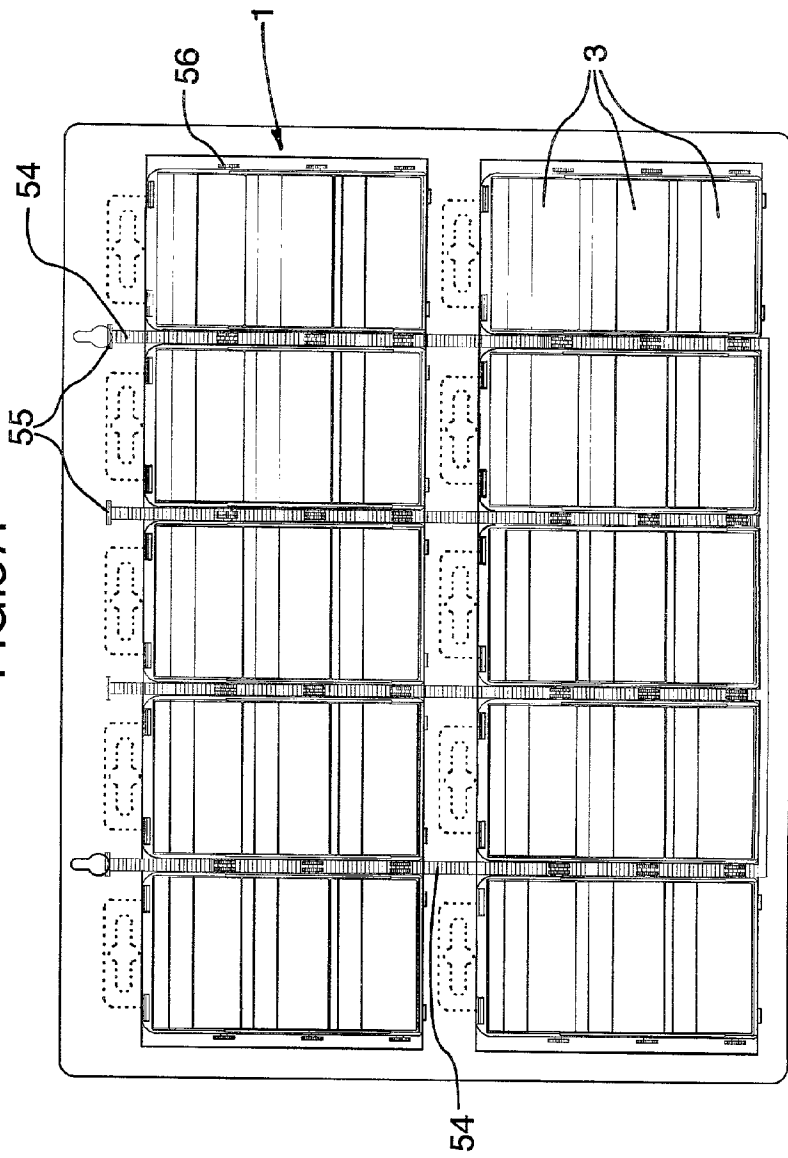

FIG. 37D

## DROP-BIN CONTAINERS AND HOLDERS FOR SAME

### REFERENCE TO RELATED APPLICATION

[0001] This is a continuation-in-part of application Ser. No. 09/422,964, filed Oct. 22, 1999.

### BACKGROUND OF THE INVENTION

[0002] This invention relates to compartmentalized containers for objects, particularly intended for hardware items and tool components, but useful for a wide variety of purposes. Other uses could include, for example, cosmetic kits, fishing tackle, organizers for medication, storage for pens, pencils, crayons, storage for various condiments in the kitchen, organizers for women's trinkets, hobby kits, recreational items, sewing kits, etc.

[0003] Although many containers exist, of course, there is always a need for new and improved containers which are easy and convenient to market and to use, and which can be easily carried around by a person, if desired (either one at a time, or several at a time).

### SUMMARY OF THE INVENTION

[0004] In the invention, an organizer is provided, having a holder and at least one container unit, the at least one container unit comprising a housing having opposing side walls, and a plurality of bins mounted between the side walls for rotation between closed and open positions, such that in the closed position, outer faces of the bins are generally coplanar, and in the open position, the outer faces each angle outwardly from the housing, thereby providing access into the bins, the bins being connected together for movement in unison, the outer faces occupying substantially all of a front portion of the housing.

[0005] Advantageously, the holder has at least upper and lower elements, the at least one container unit being securable between the upper and lower elements.

[0006] Preferably, each container unit has at least one tab at the bottom thereof, to insert into a corresponding slot in one of the upper and lower elements, and at least one catch to engage a corresponding means in the other of the upper and lower elements.

[0007] Advantageously, the organizer is a combination with another holder, connected thereto. Preferably, the organizer has two holders, one being hinged to the other along one side thereof. Alternatively, at least two holders are connected back to back, or side to side.

[0008] Preferably, the holder provides a common vertical center wall, with the container units being securable to either side thereof by any suitable means.

[0009] Advantageously, the housing has a tab extending upwardly from an upper surface thereof, the tab having an opening for hanging the at least one container unit.

[0010] The tab is either foldable against the upper surface or removable from the housing, so as not to interfere with the connection of the at least one container unit with the holder.

[0011] Preferably, a number of container units are attachable to the holder, in any of a multitude of locations, and the pivoting of the bins is actuated via pinion wheels or the like

arranged on each bin, each pinion wheel or the like being engaged in contact with a slidable rack, so that when the rack is manipulated by a user to slide up or down, or a bin is rotated, the rack causes the pinion wheel to rotate and thus the bin is caused to pivot. Advantageously, the racks are connected via at least one cross-beam, so that the manipulation of one rack causes the other racks to perform the same movement as the one rack.

[0012] The units in holders provide great flexibility for carrying job-specific items, e.g. seals and washers for plumbing jobs, Marrette™ connectors, assorted terminals, etc. for electrical jobs, and so on. Using a holder which can carry a number of drop-bin units allows the user to remove and replace units as desired, thus avoiding the need to carry an entire toolbox to a particular job.

[0013] Further features of the invention will be described or will become apparent in the detailed description which follows.

### BRIEF DESCRIPTION OF THE DRAWINGS

[0014] In order that the invention may be more clearly understood, the preferred embodiment thereof will now be described in detail by way of example, with reference to the accompanying drawings, in which:

[0015] FIG. 1 is a perspective view of the preferred embodiment of the drop-bin unit, with the bins open;

[0016] FIG. 2 is a corresponding view with the bins closed;

[0017] FIG. 3 is a top view of the unit;

[0018] FIG. 4 is a front view of the unit;

[0019] FIG. 5 is a top cross-sectional view of the unit;

[0020] FIG. 6 is a side cross-sectional view of the unit, with the bins closed;

[0021] FIG. 7 is a side cross-sectional view of the unit, with the bins open;

[0022] FIG. 8 is a rear view of the unit;

[0023] FIG. 9 is a perspective view of the rear of the unit;

[0024] FIG. 10 is a side cross-sectional view showing a clip on the rear of the unit;

[0025] FIG. 11 is a perspective view showing the unit with the clip;

[0026] FIG. 12 is a side cross-sectional view showing magnets on the rear of the unit;

[0027] FIG. 13 is a perspective view showing the unit with the magnets;

[0028] FIG. 14 is a front view showing a holder with three units mounted therein;

[0029] FIG. 15 is a top cross-sectional view showing the holder and units of FIG. 14;

[0030] FIG. 16 is a side cross-sectional view showing the holder and units of FIG. 14, with the bins open;

[0031] FIG. 17 is a perspective view showing a similar holder to that of FIGS. 14-16, but with a carrying handle;

[0032] FIG. 18 is a side cross-sectional view showing two holders, mated with each other back-to-back;

[0033] FIG. 18A is a close-up cross-sectional view showing the connection between a housing of one of the units, and one of the FIG. 18 holders;

[0034] FIG. 19 is a front view showing the holders of FIG. 18;

[0035] FIG. 20 is a top cross-sectional view of the FIG. 18 holder;

[0036] FIG. 20A is a close-up cross-sectional view showing the connection between the FIG. 18 holders;

[0037] FIG. 21 is a side cross-sectional view of a holder similar to that of FIG. 18, but fully covering the sides of the units;

[0038] FIG. 22 is a front view showing the holder of FIG. 21;

[0039] FIG. 23 is a top cross-sectional view showing the FIG. 21 holder;

[0040] FIG. 24 is a top cross-sectional view showing a holder which has two sections which are hinged to each other, shown folded shut;

[0041] FIG. 25 is a top cross-sectional view showing the FIG. 24 holder, folded open;

[0042] FIG. 26 is a front cross-sectional view showing a carousel arrangement of several units;

[0043] FIG. 27 is a top cross-sectional view of the FIG. 26 holder;

[0044] FIG. 28 is a perspective view showing a cylindrical version;

[0045] FIG. 29 is a perspective view showing the FIG. 28 version with the bins open;

[0046] FIG. 30 is a top cross-sectional view of the FIG. 28 version;

[0047] FIG. 31 is a perspective view showing a holder with three units arranged in a triangular fashion;

[0048] FIG. 32 is a top cross-sectional view showing the FIG. 31 holder;

[0049] FIG. 33 is an exploded perspective view showing the units mountable in a tool box

[0050] FIG. 34 is a side view showing an alternative means of ganging the bins, with the bins closed;

[0051] FIG. 35 is a side view showing the same alternative means of ganging the bins, with the bins open;

[0052] FIG. 36 is a perspective view corresponding to FIG. 2, showing an embodiment where the bins are not of uniform width;

[0053] FIG. 37A is a front view of bins mounted in a common frame and having means for concurrent opening of all bins when one bin is opened, showing the bins in a closed position;

[0054] FIG. 37B is a side view of the bins shown in FIG. 37A;

[0055] FIG. 37C is a top view of the bins shown in FIG. 37A;

[0056] FIG. 37D is a front view of bins mounted in a common frame and having means for concurrent opening of all bins when one bin is opened, showing the bins in an open position;

[0057] FIG. 37E is a side view of the bins shown in FIG. 37D; and

[0058] FIG. 37F is a top view of the bins shown in FIG. 37D.

#### DETAILED DESCRIPTION OF THE INVENTION

[0059] The preferred embodiment of the "drop-bin" unit 1, seen most clearly in FIGS. 1 and 2, can be sold and used on its own, or can be sold on its own intended to be used as part of a larger system, or sold together with a larger system. The unit has several bins 2 arranged to pivot outwardly about a generally horizontal axis. FIG. 1 shows the bins pivoted outwardly to an open position, and FIG. 2 shows the bins in their closed position where outer faces 3 of the bins are generally aligned vertically with each other.

[0060] The larger system could be, for example, a holder which is configured to receive one or many such drop-bins forming an organizer. The holder could be, for example, a holder 50 as shown in FIG. 14. This and other holders are described in detail below, as specific examples only. Alternatively, the holder could be a tool box 59, as shown in FIG. 33, i.e. one or more units could be fitted into recesses in the outside 60 of a tool box or could be snapped below the lid 61 of the tool box.

[0061] More will be said about various holder options later, but first the preferred embodiment of the drop bin unit will be described in detail.

[0062] Within each drop-bin unit 1, the bins 2 are stacked one above another within a housing 4, and are connected together, for example via at least one gang bar 5 connecting the bins to each other, such that pivoting one bin outwardly causes all of the ganged bins to pivot outwardly in unison. There could be one gang bar only, or one gang bar along each side of the bins. Alternatively, the bins could be connected in the manner shown in FIGS. 34 and 35, described in greater detail below, or in any other suitable fashion.

[0063] Each gang bar is connected to the bins by protruding pins 6 located along its length which fit into holes in the side walls of each bin. Alternatively, it should be clear that the pins could protrude from the side walls of each bin, to fit into holes in the gang bar. The bins pivot in the housing via pins 7 on either side of the bins. Obviously, these could be pins extending from the bins into holes or depressions in the housing, or vice versa.

[0064] The bins are kept in their closed position by a flexible plastic tab 8 at the top of the housing, the tab having a lip extending just slightly downwardly to catch the uppermost bin. The tab could be configured as shown in FIGS. 1 and 2, or with slots on either side thereof as in FIG. 3, for cantilevering to promote flexibility. Any other suitable means of securing the bins to the housing could be used. To open the bins, pulling slightly on one of them is enough to

disengage the tab **8**, to allow the bins to rotate. Alternatively, in some embodiments, it could be made necessary that the tab must be manually dislodged in order for the bins to be openable. Closing the bins causes the lip to catch the uppermost bin slightly, so that they remain closed until pulled outwardly again.

[0065] The entire unit preferably is molded plastic, but the entire assembly and/or one or more of the bins could be of metal or other suitable material, to permit other uses. For example, the unit to be used as a combination ashtray/coinc holder.

[0066] Preferably, each drop-bin unit is fitted with a tab **10**, with a hole for hanging on a peg hook at the point of sale or in the purchasers workshop. The tab can be fixed, but preferably has a living hinge where it joins the body of the housing, so that it can be folded flat, as shown in **FIG. 13**, if the unit is to be snapped into a holder. Alternatively, it can be frangible, so that it can be broken off by the purchaser if desired, or otherwise easily removable from the drop-bin unit.

[0067] Preferably, each unit can also have keyhole opening **11** on a rear surface, for hanging the unit on a nail, screw, etc.

[0068] Optionally, as shown in **FIGS. 10 and 11**, each unit can be provided with a molded/detachable clip **14** that can enable clipping on a rail (individually or side-by-side) or carrying on a belt or in a pocket.

[0069] Alternatively, as shown in **FIGS. 12 and 13**, the units can be fitted with one or more adhesive-backed magnets **16** to facilitate mounting on any metal surface, i.e. the side of a metal tool box, refrigerator, etc.

[0070] Similarly, the units could have a Velcro™ hook or pile strip (not shown) that would allow it to be secured to a counterpart strip on another object, for example the sun visor in an automobile.

[0071] Larger systems can be assembled by fitting individual drop-bin units together, either back-to-back or side-by-side, using a variety of means, i.e. pins and holes, slots, tongue-and-groove, etc. Alternatively, larger systems can be assembled by snapping one or more units into various holders, as mentioned previously. Various holder options will now be described in greater detail.

[0072] As shown in **FIGS. 14-16**, for example, a separate holder **50** can be provided that will enable drop-bins to be snapped in. As seen in **FIGS. 1 and 2**, the units preferably have two tabs **51** at the bottom thereof, to insert into corresponding slots in the holder **50**. The units also preferably have two springy catches **52** at the top thereof, with a lip portion which projects slightly upwardly, such that when the tabs **51** are inserted, and the unit is then rotated into the holder, the catches **52** cause the lip portions to snap into corresponding slots in the top of the holder. The units can be removed by depressing the catch slightly to disengage the lip portions from the slots.

[0073] **FIGS. 14-16** show a holder with three units mounted therein. Obviously, however, there could be only one unit, if desired, or many.

[0074] As illustrated in various drawings, the holder can be fabricated with a handle for carrying (e.g. **FIG. 17**), and/or keyhole openings at the rear for wall mounting (**FIG. 19**).

[0075] **FIG. 18** is an example showing two holders **50** and **50'**, mated with each other back-to-back. **FIG. 18A** shows one example of how the housings **4** can be connected to the holder **50**. **FIG. 19** is a front view showing the holders of **FIG. 18**. **FIG. 20** is a top cross-sectional view. **FIG. 20A** is a close-up cross-sectional view again showing one example of how the housings **4** can be connected to the holder **50**.

[0076] **FIG. 21** is a side cross-sectional view showing another alternative with two holders **50** and **50'**, similar to that of **FIG. 18** but fully covering the top, bottom and sides of the units. **FIG. 22** is a front view showing the holder of **FIG. 21**, and **FIG. 23** is a top cross-sectional view.

[0077] **FIG. 24** is a top cross-sectional view showing a holder which has two sections **50** and **50'** which are hinged to each other by a hinge **55**, shown folded shut. A catch **56** engages a notch **57** to hold the section together, or any other suitable catch or closure means could be used. **FIG. 25** shows the **FIG. 24** holder, folded open.

[0078] **FIG. 26** is a front cross-sectional view showing a carousel arrangement of several units. The bins snap between top and bottom plates **60** and **61** respectively, mounted on a base **62**. A handle **63** is provided, for carrying or rotating the assembly. **FIG. 27** is a top cross-sectional view of the **FIG. 26** holder.

[0079] **FIG. 28** is a perspective view showing a cylindrical version, where wedge-shaped bins are mounted between upper and lower plates **60** and **61** around a central post assembly **64**. **FIG. 29** is a perspective view showing the **FIG. 28** version with the bins open. **FIG. 30** is a top cross-sectional view of the **FIG. 28** version.

[0080] **FIG. 31** is a perspective view showing a holder with three units arranged in a triangular fashion between top and bottom plates **60** and **61**. **FIG. 32** is a top cross-sectional view showing the **FIG. 31** holder

[0081] **FIG. 33** is an exploded perspective view showing the units mountable in a tool box.

[0082] To summarize some possible variations on the holders, they can be attached to each other in a variety of ways:

[0083] a. back-to-back such that drop-bins are accessible from either side;

[0084] b. side-by-side such that drop-bins are accessible from the same side;

[0085] c. top-to-bottom such that drop-bins are accessible from the same side;

[0086] d. top-to-bottom, and/or back-to-back, and/or side-to-side;

[0087] e. holders can be molded and connected together via a living hinge. The holder, in this case, can be folded and secured back-to-back to provide access to the drop-bins from either side; or

[0088] f. the holder can be swung open and be flat, in which case, all the drop bins are accessible from the same side.

[0089] Also, double-thickness holders can be molded that will accept drop-bins in either direction.

[0090] The holders can be fabricated in many shapes and configurations, having drop-bins of corresponding shapes:

[0091] a. a circular holder around which drop-bins are installed. The holder can be rotated to select a particular bin/contents;

[0092] b. the holder can be polygonal, inserted into a swivel base, and equipped with a turning knob at the top (to rotate holder);

[0093] c. the holder can have a common wall (with or without a handle) onto which drop-bins can be attached from either side using various means (mentioned previously).

[0094] Yet another variation is that the holder could have a common vertical center wall, with drop-bin units secured to either side thereof by any suitable means

[0095] FIGS. 34 and 35 illustrate an alternative means of ganging the bins, i.e. instead of using gang bars. In this embodiment, the bins pivot on pins 75. Pins 70 from one bin ride in a slot 71 in a flange 72 attached to the side of the adjacent bin. By virtue of the geometry of the slot 71, rotating one bin 2 causes the wall of the slot to act on the pin of the adjacent bin, to cause that bin to rotate as well.

[0096] A further variation is that the width of the bins could be varied or split. For example, as shown in FIG. 36, one or more of the bins could be split into two separate bins, one ganged from one side and the other ganged from the other side.

[0097] FIGS. 37A to 37F show an embodiment of the invention, in which a number of drop-bin units 1 are attachable to a frame 53, in any of a multitude of locations. The pivoting of the bins 2 is actuated via pinion wheels 56 arranged on each bin. Each pinion wheel of a drop-bin unit seated in the frame is engaged in contact with a slidable rack 54, so that when the rack is manipulated by a user, via a finger tab 55 for instance, to slide up or down (as is shown in the figures), the rack causes the pinion wheel to rotate and thus the bin to pivot. The racks are connected via a cross-beam 57, so that the manipulation of one causes the other racks to perform the same movement. Thus, by manipulating one rack, all the drop-bin units 1 that are inserted into the frame have their bins pivoted simultaneously and the same amount. The drop-bin units are held in the frame by friction or by retaining means (not shown). FIGS. 37A to 37C show a frame being full of inserted drop-bin units and the racks in a position to pivot all bins to a closed position. If one location in the frame is empty, i.e. no drop-bin unit is inserted, the pivoting of bins of the drop-bin units that are inserted into the frame is not interrupted, because the racks run the length of the frame to engage any possible pinion wheel of any inserted drop-bin unit in any possible location on the frame.

1. An organizer having a holder and at least one container unit, said at least one container unit comprising a housing

having opposing side walls, and a plurality of bins mounted between said side walls for rotation between closed and open positions, such that in said closed position, outer faces of said bins are generally coplanar, and in said open position, said outer faces each angle outwardly from said housing, thereby providing access into said bins, said bins being connected together for movement in unison, said outer faces occupying substantially all of a front portion of said housing.

2. An organizer as recited in claim 1, wherein said holder comprises at least upper and lower elements, said at least one container unit being securable between said upper and lower elements.

3. An organizer as recited in claim 2, wherein each said container unit has at least one tab at the bottom thereof, to insert into a corresponding slot in one of said upper and lower elements, and at least one catch to engage a corresponding means in the other of said upper and lower elements.

4. An organizer as recited in claim 1, in further combination with another said holder, connected thereto.

5. An organizer as recited in claim 4, comprising two said holders, one being hinged to the other along one side thereof.

6. An organizer as recited in claim 4, comprising two said holders, connected back to back.

7. An organizer as recited in claim 4, comprising at least two said holders, connected side to side.

8. An organizer as recited in claim 1, wherein said holder provides a common vertical center wall, with said container units being securable to either side thereof by any suitable means.

9. An organizer as recited in claim 1, wherein said housing has a tab extending upwardly from an upper surface thereof, said tab having an opening for hanging said at least one container unit.

10. An organizer as recited in claim 9, wherein said tab is foldable against said upper surface so as not to interfere with the connection of said at least one container unit with said holder.

11. An organizer as recited in claim 9, wherein said tab is removable from said housing so as not to interfere with the connection of said at least one container unit with said holder.

12. An organizer as recited in claim 1, wherein a number of container units are attachable to said holder, in any of a multitude of locations, and the pivoting of said bins is actuated via pinion wheels arranged on each said bin, each pinion wheel being engaged in contact with a slidable rack, so that when a bin or rack is manipulated by a user, said manipulation causes rotation of said pinion wheel and movement of said bin and rack.

13. An organizer as recited in claim 12, wherein said racks are connected via at least one cross-beam, so that the manipulation of one said rack or bin causes the other racks and bins to perform the same movement as said one rack or bin.

\* \* \* \* \*