



(86) Date de dépôt PCT/PCT Filing Date: 2001/03/22
 (87) Date publication PCT/PCT Publication Date: 2001/09/27
 (45) Date de délivrance/Issue Date: 2003/04/22
 (85) Entrée phase nationale/National Entry: 2002/08/19
 (86) N° demande PCT/PCT Application No.: US 2001/040364
 (87) N° publication PCT/PCT Publication No.: 2001/070376
 (30) Priorités/Priorities: 2000/03/23 (60/191,891) US;
 2001/03/19 (09/812,499) US

(51) Cl.Int.⁷/Int.Cl.⁷ B01D 53/22
 (72) Inventeurs/Inventors:
 EDLUND, DAVID J., US;
 PLEDGER, WILLIAM A., US;
 STUDEBAKER, TODD, US
 (73) Propriétaire/Owner:
 IDATECH, LLC, US
 (74) Agent: SMART & BIGGAR

(54) Titre : MODULES DE MEMBRANES METALLIQUES A SELECTIVITE POUR L'HYDROGENE ET PROCEDES DE FABRICATION

(54) Title: HYDROGEN-SELECTIVE METAL MEMBRANE MODULES AND METHOD OF FORMING THE SAME

(57) **Abrégé/Abstract:**

Membrane modules that contain one or more hydrogen-selective membranes, methods for preparing the same, and hydrogen purification systems, fuel processors and devices containing the same. In some embodiments, the membrane modules include one or more hydrogen-selective membranes supported on a screen structure, of which a variety of embodiments are disclosed. In some embodiments, the membrane or membranes are adhesively mounted on the screen structure during assembly. In some embodiments, the screen structure includes a plurality of screen members adhesively mounted together during assembly. In some embodiments, the screen structure includes a coating.

(12) INTERNATIONAL APPLICATION PUBLISHED UNDER THE PATENT COOPERATION TREATY (PCT)

(19) World Intellectual Property Organization
International Bureau



(43) International Publication Date
27 September 2001 (27.09.2001)

PCT

(10) International Publication Number
WO 01/70376 A1

- (51) International Patent Classification⁷: **B01D 53/22**
- (74) Agent: **D'ASCENZO, David, S.**; Kolisch, Hartwell, Dickinson, McCormack & Heuser, P.C., Suite 200, 520 S.W. Yamhill Street, Portland, OR 97204 (US).
- (21) International Application Number: PCT/US01/40364
- (22) International Filing Date: 22 March 2001 (22.03.2001)
- (81) Designated States (*national*): AE, AG, AL, AM, AT, AU, AZ, BA, BB, BG, BR, BY, BZ, CA, CH, CN, CO, CR, CU, CZ, DE, DK, DM, DZ, EE, ES, FI, GB, GD, GE, GH, GM, HR, HU, ID, IL, IN, IS, JP, KE, KG, KP, KR, KZ, LC, LK, LR, LS, LT, LU, LV, MA, MD, MG, MK, MN, MW, MX, MZ, NO, NZ, PL, PT, RO, RU, SD, SE, SG, SI, SK, SL, TJ, TM, TR, TT, TZ, UA, UG, US, UZ, VN, YU, ZA, ZW.
- (25) Filing Language: English
- (26) Publication Language: English
- (30) Priority Data:
60/191,891 23 March 2000 (23.03.2000) US
09/812,499 19 March 2001 (19.03.2001) US
- (84) Designated States (*regional*): ARIPO patent (GH, GM, KE, LS, MW, MZ, SD, SL, SZ, TZ, UG, ZW), Eurasian patent (AM, AZ, BY, KG, KZ, MD, RU, TJ, TM), European patent (AT, BE, CH, CY, DE, DK, ES, FI, FR, GB, GR, IE, IT, LU, MC, NL, PT, SE, TR), OAPI patent (BF, BJ, CF, CG, CI, CM, GA, GN, GW, ML, MR, NE, SN, TD, TG).
- (71) Applicant (*for all designated States except US*): **IDATECH, LLC** [US/US]; P.O. Box 5339, Bend, OR 97708-5339 (US).

- (72) Inventors; and
(75) Inventors/Applicants (*for US only*): **EDLUND, David, J.** [US/US]; 1698 Davenport, Bend, OR 97701 (US). **PLEDGER, William, A.** [US/US]; 69222 Harness, Sisters, OR 97759 (US). **STUDEBAKER, Todd** [US/US]; 3029 N.E. Charleston Court, Bend, OR 97701 (US).

Published:

— with international search report

For two-letter codes and other abbreviations, refer to the "Guidance Notes on Codes and Abbreviations" appearing at the beginning of each regular issue of the PCT Gazette.

(54) Title: HYDROGEN-SELECTIVE METAL MEMBRANE MODULES AND METHOD OF FORMING THE SAME

(57) Abstract: Membrane modules that contain one or more hydrogen-selective membranes, methods for preparing the same, and hydrogen purification systems, fuel processors and devices containing the same. In some embodiments, the membrane modules include one or more hydrogen-selective membranes supported on a screen structure, of which a variety of embodiments are disclosed. In some embodiments, the membrane or membranes are adhesively mounted on the screen structure during assembly. In some embodiments, the screen structure includes a plurality of screen members adhesively mounted together during assembly. In some embodiments, the screen structure includes a coating.



WO 01/70376 A1

HYDROGEN-SELECTIVE METAL MEMBRANE MODULES AND METHOD OF FORMING THE SAME

Field of the Invention

The invention relates generally to hydrogen purification systems and
5 more particularly to hydrogen-selective membranes, methods for forming membrane
modules containing a plurality of hydrogen-selective membranes, and hydrogen
producing and purifying systems containing the same.

Background of the Invention

Hydrogen-selective membranes formed from hydrogen-permeable
10 metals, most notably palladium and alloys of palladium, are known. In particular,
planar palladium-alloy membranes have been disclosed for purifying hydrogen gas
streams, such as hydrogen gas streams produced by steam reformers, autothermal
reformers, partial oxidation reactors, pyrolysis reactors and other fuel processors,
including fuel processors configured to supply purified hydrogen to fuel cells or other
15 processes requiring high-purity hydrogen.

To be economical, palladium and palladium-alloy membranes must be
thin. For example, planar membranes are typically approximately 0.001 inches thick.
However, these extremely thin membranes are subject to wrinkling during assembly
into a membrane module containing one or more hydrogen-selective membranes. A
20 membrane that has one or more wrinkles is subject to premature failure due to stress
fractures forming at the wrinkle. When such a failure occurs, impurities that
otherwise would be unable to pass through the membrane can now pass through the
membrane, thereby reducing the purity of the product hydrogen stream and potentially
damaging the fuel cell stack or other hydrogen-consuming device with which the
25 purified stream is used.

Therefore, there is a need for a method for preparing hydrogen-
selective membranes for use in a fuel processor or other hydrogen-purifying device
without wrinkling the membranes.

Summary of the Invention

30 The present invention is directed to membrane modules that contain
one or more hydrogen-selective membranes, methods for preparing the same, and
hydrogen purification systems, fuel processors and devices containing the same. In
some embodiments, the membrane modules include one or more hydrogen-selective

membranes supported on a screen structure, of which a variety of embodiments are disclosed. In some embodiments, the membrane or membranes are adhesively mounted on the screen structure during assembly. In some embodiments, the screen structure includes a plurality of screen members adhesively mounted together during assembly. In some embodiments, the screen structure includes a coating.

In accordance with one aspect of the invention, there is provided a hydrogen purification assembly. The assembly includes a membrane module adapted to receive a mixed gas stream containing hydrogen gas and other gases, a product output through which a product stream is removed from the membrane module, and a byproduct output through which a byproduct stream is removed from the membrane module. The product stream contains at least substantially hydrogen gas, and the byproduct stream contains at least a substantial portion of the other gases. The assembly further includes at least one membrane envelope. The at least one membrane envelope includes a pair of hydrogen-selective membrane regions. Each membrane region has a feed side and a permeate side, and the membrane regions are spaced-apart from each other with their permeate sides facing each other and defining a harvesting conduit extending therebetween. The harvesting conduit is in fluid communication with the product output to enable gas passing through the membrane regions into the harvesting conduit to be withdrawn from the membrane module through the product output. The feed sides are in fluid communication with the mixed gas stream. The at least one membrane envelope further includes a support within the harvesting conduit. The support is adapted to support the permeate sides of the membrane regions, and includes a pair of generally opposed contact surfaces that are adapted to respectively support the permeate sides of the pair of membrane regions. The contact surfaces are selected from the group consisting of contact surfaces that include a coating adapted to prevent intermetallic diffusion between the contact surfaces and the membrane regions and contact surfaces that are formed from an expanded metal material.

In accordance with another aspect of the invention, there is provided a method for forming a hydrogen-selective membrane module. The method includes providing a pair of hydrogen-selective metal membranes having feed sides and permeate sides, and providing a

-2A-

support including outer surfaces through which hydrogen gas may flow. The method further includes adhesively mounting the permeate side of one of the hydrogen-selective metal membranes to one of the outer surfaces of the support and adhesively mounting the permeate side of another of the hydrogen-selective metal membranes to the other of the outer surfaces of the support to form a membrane envelope having a harvesting conduit extending between the permeate sides of the hydrogen-selective metal membranes. The method also includes placing the membrane envelope in a membrane module having a pair of end plates, and subjecting the membrane module to oxidizing conditions to remove at least a substantial portion of the adhesive.

Other aspects and features of the present invention will become apparent to those ordinarily skilled in the art upon review of the following description of specific embodiments of the invention in conjunction with the accompanying figures.

Brief Description of the Drawings

Fig. 1 is a schematic diagram of a fuel cell system containing a fuel processor with a membrane module according to the present invention.

Fig. 2 is a schematic diagram of another embodiment of the fuel cell system of Fig. 1.

Fig. 3 is a schematic diagram of a fuel processor suitable for use in the fuel cell systems of Figs. 1 and 2 and including a membrane module according to the present invention.

Fig. 4 is a schematic diagram of another embodiment of the fuel processor of Fig. 3.

Fig. 5 is a schematic diagram of a hydrogen purifier containing a membrane module according to the present invention.

Fig. 6 is a fragmentary side elevation view of a membrane envelope constructed according to the present invention and including a screen structure.

Fig. 7 is an exploded isometric view of another embodiment of a membrane envelope constructed according to the present invention and including a screen structure having several layers.

-2B-

Fig. 8 is a cross-sectional view of the membrane envelope of Fig. 7.

Fig. 9 is a fragmentary isometric view of an expanded metal screen member suitable for use in the screen structure of Fig. 7.

Fig. 10 is an exploded isometric view of another membrane envelope according to the present invention.

Fig. 11 is an exploded isometric view of another membrane envelope constructed according to the present invention.

Fig. 12 is an exploded isometric view of another membrane envelope constructed according to the present invention.

Fig. 13 is an exploded isometric view of another membrane module constructed according to the present invention.

Fig. 14 is a cross-sectional view of a fuel processor that includes a membrane module constructed according to the present invention.

Fig. 15 is a cross-sectional view of another fuel processor that includes a membrane module constructed according to the present invention.

5 Detailed Description and Best Mode of the Invention

A fuel cell system according to the present invention is shown in Fig. 1 and generally indicated at 10. System 10 includes at least one fuel processor 12 and at least one fuel cell stack 22. Fuel processor 12 is adapted to produce a product hydrogen stream 14 containing hydrogen gas from a feed stream 16 containing a feedstock. The fuel cell stack is adapted to produce an electric current from the portion of product hydrogen stream 14 delivered thereto. In the illustrated embodiment, a single fuel processor 12 and a single fuel cell stack 22 are shown and described, however, it should be understood that more than one of either or both of these components may be used. It should also be understood that these components have been schematically illustrated and that the fuel cell system may include additional components that are not specifically illustrated in the figures, such as feed pumps, air delivery systems, heat exchangers, heating assemblies and the like.

Fuel processor 12 produces hydrogen gas through any suitable mechanism. Examples of suitable mechanisms include steam reforming and autothermal reforming, in which reforming catalysts are used to produce hydrogen gas from a feed stream containing a carbon-containing feedstock and water. Other suitable mechanisms for producing hydrogen gas include pyrolysis and catalytic partial oxidation of a carbon-containing feedstock, in which case the feed stream does not contain water. Still another suitable mechanism for producing hydrogen gas is electrolysis, in which case the feedstock is water. For purposes of illustration, the following discussion will describe fuel processor 12 as a steam reformer adapted to receive a feed stream 16 containing a carbon-containing feedstock 18 and water 20. However, it is within the scope of the invention that the fuel processor 12 may take other forms, as discussed above.

30 Examples of suitable carbon-containing feedstocks include at least one hydrocarbon or alcohol. Examples of suitable hydrocarbons include methane, propane, natural gas, diesel, kerosene, gasoline and the like. Examples of suitable

alcohols include methanol, ethanol, and polyols, such as ethylene glycol and propylene glycol.

Feed stream 16 may be delivered to fuel processor 12 via any suitable mechanism. Although only a single feed stream 16 is shown in Fig. 1, it should be understood that more than one stream 16 may be used and that these streams may contain the same or different components. When carbon-containing feedstock 18 is miscible with water, the feedstock is typically delivered with the water component of feed stream 16, such as shown in Fig. 1. When the carbon-containing feedstock is immiscible or only slightly miscible with water, these components are typically delivered to fuel processor 12 in separate streams, such as shown in Fig. 2.

In Figs. 1 and 2, feed stream 16 is shown being delivered to fuel processor 12 by a feed stream delivery system 17. Delivery system 17 includes any suitable mechanism, device, or combination thereof that delivers the feed stream to fuel processor 12. For example, the delivery system may include one or more pumps that deliver the components of stream 16 from a supply. Additionally, or alternatively, system 17 may include a valve assembly adapted to regulate the flow of the components from a pressurized supply. The supplies may be located external of the fuel cell system, or may be contained within or adjacent the system.

Fuel cell stack 22 contains at least one, and typically multiple, fuel cells 24 adapted to produce an electric current from the portion of the product hydrogen stream 14 delivered thereto. This electric current may be used to satisfy the energy demands, or applied load, of an associated energy-consuming device 25. Illustrative examples of devices 25 include, but should not be limited to, a motor vehicle, recreational vehicle, boat, tool, light or lighting assemblies, appliances (such as household or other appliances), household, signaling or communication equipment, etc. It should be understood that device 25 is schematically illustrated in Fig. 1 and is meant to represent one or more devices or collection of devices that are adapted to draw electric current from the fuel cell system. A fuel cell stack typically includes multiple fuel cells joined together between common end plates 23, which contain fluid delivery/removal conduits (not shown). Examples of suitable fuel cells include proton exchange membrane (PEM) fuel cells and alkaline fuel cells. Fuel cell stack 22 may receive all of product hydrogen stream 14. Some or all of stream 14 may

additionally, or alternatively, be delivered, via a suitable conduit, for use in another hydrogen-consuming process, burned for fuel or heat, or stored for later use.

Fuel processor 12 is any suitable device that produces hydrogen gas. Preferably, the fuel processor is adapted to produce substantially pure hydrogen gas, and even more preferably, the fuel processor is adapted to produce pure hydrogen gas. For the purposes of the present invention, substantially pure hydrogen gas is greater than 90% pure, preferably greater than 95% pure, more preferably greater than 99% pure, and even more preferably greater than 99.5% pure. Suitable fuel processors are disclosed in U.S. Patent Nos. 5,997,594, 5,861,137, and 6,221,117, and U.S. Patent Application Publication No. U.S. 2001/0045061 A1, which was published on November 29, 2001.

An example of a suitable fuel processor 12 is a steam reformer. An example of a suitable steam reformer is shown in Fig. 3 and indicated generally at 30. Reformer 30 includes a reforming, or hydrogen-producing, region 32 that includes a steam reforming catalyst 34. Alternatively, reformer 30 may be an autothermal reformer that includes an autothermal reforming catalyst. In reforming region 32, a reformat stream 36 is produced from the water and carbon-containing feedstock forming feed stream 16. The reformat stream typically contains hydrogen gas and impurities, and therefore is delivered to a separation region, or purification region, 38, where the hydrogen gas is purified. In separation region 38, the hydrogen-containing stream is separated into one or more byproduct streams, which are collectively illustrated at 40, and a hydrogen-rich stream 42 by any suitable pressure-driven separation process. In Fig. 3, hydrogen-rich stream 42 is shown forming product hydrogen stream 14. Separation region 38 includes a membrane module 44 according to the present invention and contains one or more hydrogen-selective membranes 46. Membrane module 44 is discussed and illustrated in more detail subsequently.

Reformer 30 may, but does not necessarily, further include a polishing region 48, such as shown in Fig. 4. Polishing region 48 receives hydrogen-rich stream 42 from separation region 38 and further purifies the stream by reducing the concentration of, or removing, selected compositions therein. For example, when

stream 42 is intended for use in a fuel cell stack, such as stack 22, compositions that may damage the fuel cell stack, such as carbon monoxide and carbon dioxide, may be removed from the hydrogen-rich stream. The concentration of carbon monoxide should be less than 10 ppm (parts per million) to prevent the control system from isolating the fuel cell stack. Preferably, the system limits the concentration of carbon monoxide to less than 5 ppm, and even more preferably, to less than 1 ppm. The concentration of carbon dioxide may be greater than that of carbon monoxide. For example, concentrations of less than 25% carbon dioxide may be acceptable. Preferably, the concentration is less than 10%, even more preferably, less than 1%. Especially preferred concentrations are less than 50 ppm. It should be understood that the acceptable minimum concentrations presented herein are illustrative examples, and that concentrations other than those presented herein may be used and are within the scope of the present invention. For example, particular users or manufacturers may require minimum or maximum concentration levels or ranges that are different than those identified herein.

Region 48 includes any suitable structure for removing or reducing the concentration of the selected compositions in stream 42. For example, when the product stream is intended for use in a PEM fuel cell stack or other device that will be damaged if the stream contains more than determined concentrations of carbon monoxide or carbon dioxide, it may be desirable to include at least one methanation catalyst bed 50. Bed 50 converts carbon monoxide and carbon dioxide into methane and water, both of which will not damage a PEM fuel cell stack. Polishing region 48 may also include another hydrogen-producing device 52, such as another reforming catalyst bed, to convert any unreacted feedstock into hydrogen gas. In such an embodiment, it is preferable that the second reforming catalyst bed is upstream from the methanation catalyst bed so as not to reintroduce carbon dioxide or carbon monoxide downstream of the methanation catalyst bed.

Steam reformers typically operate at temperatures in the range of 200° C and 700° C, and at pressures in the range of 50 psi and 1000 psi, although temperatures outside of this range are within the scope of the invention, such as depending upon the particular type and configuration of fuel processor being used. Any suitable heating mechanism or device may be used to provide this heat, such as a heater, burner, combustion catalyst, or the like. The heating assembly may be

[JUS 01 / 40364
IPEAUS 14 JAN 2002

PCT:US01/40364 14012002

external the fuel processor or may form a combustion chamber that forms part of the fuel processor. The fuel for the heating assembly may be provided by the fuel processing system, or fuel cell system, by an external source, or both.

In Figs. 3 and 4, reformer 30 is shown including a shell 31 in which the
5 above-described components are contained. Shell 31, which also may be referred to as a housing, enables the fuel processor, such as reformer 30, to be moved as a unit. It also protects the components of the fuel processor from damage by providing a protective enclosure and reduces the heating demand of the fuel processor because the components of the fuel processor may be heated as a unit. Shell 31 may, but does not
10 necessarily, include insulating material 33, such as a solid insulating material, blanket insulating material, or an air-filled cavity. It is within the scope of the invention, however, that the reformer may be formed without a housing or shell. When reformer 30 includes insulating material 33, the insulating material may be internal the shell, external the shell, or both. When the insulating material is external a shell containing
15 the above-described reforming, separation and/or polishing regions, the fuel processor may further include an outer cover or jacket external the insulation.

It is further within the scope of the invention that one or more of the components may either extend beyond the shell or be located external at least shell 31. For example, and as schematically illustrated in Fig. 4, polishing region 48 may
20 be external shell 31 and/or a portion of reforming region 32 may extend beyond the shell.

Although fuel processor 12, feed stream delivery system 17, fuel cell stack 22 and energy-consuming device 25 may all be formed from one or more discrete components, it is also within the scope of the invention that two or more of
25 these devices may be integrated, combined or otherwise assembled within an external housing or body. For example, a fuel processor and feed stream delivery system may be combined to provide a hydrogen-producing device with an on-board, or integrated, feed stream delivery system, such as schematically illustrated at 26 in Fig. 1. Similarly, a fuel cell stack may be added to provide an energy-generating device with
30 an integrated feed stream delivery system, such as schematically illustrated at 27 in Fig. 1.

Fuel cell system 10 may additionally be combined with an energy-consuming device, such as device 25, to provide the device with an integrated, or on-

board, energy source. For example, the body of such a device is schematically illustrated in Fig. 1 at 28. Examples of such devices include a motor vehicle, such as a recreational vehicle, automobile, boat or other seacraft, and the like, a dwelling, such as a house, apartment, duplex, apartment complex, office, store or the like, or a self-contained equipment, such as an appliance, light, tool, microwave relay station, transmitting assembly, remote signaling or communication equipment, etc.

It is within the scope of the invention that the above-described fuel processor 12 may be used independent of a fuel cell stack. In such an embodiment, the system may be referred to as a fuel processing system, and it may be used to provide a supply of pure or substantially pure hydrogen to a hydrogen-consuming device, such as a burner for heating, cooking or other applications. Similar to the above discussion about integrating the fuel cell system with an energy-consuming device, the fuel processor and hydrogen-consuming device may be combined, or integrated.

It is also within the scope of the present invention that the membrane modules disclosed herein may be used as a hydrogen purifier independent of a fuel processor or fuel cell stack. An example of a membrane module 44 configured for use as a hydrogen-purifier is schematically illustrated in Fig. 5 and generally indicated at 60. As shown, a mixed gas stream 61 containing hydrogen gas 62 and other gases 63 is delivered to purifier 60, which contains a membrane module 44 constructed according to the present invention. The membrane module contains at least one hydrogen-selective membrane 46, and separates the mixed gas stream into a product stream 64 containing at least substantially hydrogen gas and a byproduct stream 65 containing at least substantially the other gases. Another way to describe the purifier is that the product stream contains at least a substantial portion of the hydrogen gas in the mixed gas stream and that the byproduct stream contains at least a substantial portion of the other gases. Similar to the fuel processors and fuel cell systems discussed above, purifier 60 may be integrated with a hydrogen-producing device to provide a hydrogen-producing device with an integrated hydrogen purifier and/or with a hydrogen-consuming device to provide a hydrogen-consuming device with an integrated hydrogen purifier.

It should be understood that the hydrogen purity of the product stream, the hydrogen content of the byproduct stream, the percentage of hydrogen from the

mixed gas stream that forms the byproduct stream, and similar compositions of the product and byproduct streams may be selectively varied depending upon the construction of the membrane module and/or the operating conditions within which the membrane module is used. For example, the compositions of the product and byproduct streams may vary at least partially in response to at least the following factors: the temperature of the membrane module, the pressure of the membrane module, the composition of the hydrogen-selective membrane, the state of wear of the hydrogen-selective membrane, the thickness of the hydrogen-selective membrane, the composition of the mixed gas stream, the number of hydrogen-selective membranes used in the membrane module, and the number of sequential membranes through which the mixed gas, product and/or byproduct streams may pass.

As discussed, a suitable structure for use in separation region 38 is a membrane module 44, which contains one or more hydrogen-permeable and hydrogen-selective membranes 46. The membranes may be formed of any hydrogen-selective material suitable for use in the operating environment and conditions in which the membrane module is operated, such as in a purifier, fuel processor or the like. Examples of suitable materials for membranes 46 are palladium and palladium alloys, and especially thin films of such metals and metal alloys. Palladium alloys have proven particularly effective, especially palladium with 35 wt% to 45 wt% copper. These membranes are typically formed from a thin foil that is approximately 0.001 inches thick. It is within the scope of the present invention, however, that the membranes may be formed from hydrogen-selective metals and metal alloys other than those discussed above and that the membranes may have thicknesses that are larger or smaller than discussed above. For example, the membrane may be made thinner, with commensurate increase in hydrogen flux. Suitable mechanisms for reducing the thickness of the membrane include rolling, sputtering and etching. A suitable etching process is disclosed in U.S. Patent No. 6,152,995.

The hydrogen-permeable membranes may be arranged in pairs around a common permeate channel to form a membrane envelope, as is disclosed in the patents and published patent applications referred to herein and as schematically illustrated in Fig. 6 at 66.
In

PT 01 / 40364
IPEAUS 14 JAN 2002

PCT. US01/40364, 14012002

such a configuration, the membrane pairs may be referred to as a membrane envelope, in that they define a common permeate channel, or harvesting conduit, through which the permeated gas may be collected and removed to form hydrogen-rich stream 42 (or product hydrogen stream 14 or purified hydrogen stream 64, depending on the particular implementation of the membrane module).

It should be understood that the membrane pairs may take a variety of suitable shapes, such as planar envelopes and tubular envelopes. Similarly, the membranes may be independently supported, such as with respect to an end plate or around a central passage. For purposes of illustration, the following description and associated illustrations will describe the membrane module as including one or more membrane envelopes 66. It should be understood that the membranes forming the envelope may be two separate membranes, or may be a single membrane folded, rolled or otherwise configured to define two membrane regions, or surfaces, 67 with permeate faces 68 that are oriented toward each other to define a conduit 69 therebetween from which the permeate gas may be collected and withdrawn.

To support the membranes against high feed pressures, a support, or screen structure, 70 is used. Screen structure 70 provides support to the hydrogen-selective membranes, and more particularly includes surfaces 71 that against which the permeate sides 68 of the membranes are supported. Screen structure 70 also defines harvesting conduit 69, through which permeated gas may flow both transverse and parallel to the surface of the membrane through which the gas passes, such as schematically illustrated in Fig. 6. The permeate gas, which is at least substantially pure hydrogen gas, may then be harvested or otherwise withdrawn from the membrane module, such as to form streams 42, 64, and/or 14. Because the membranes lie against the screen structure, it is preferable that the screen structure does not obstruct the flow of gas through the hydrogen-selective membrane. The gas that does not pass through the membranes forms one or more byproduct streams, as schematically illustrated in Fig. 6.

To reiterate, the membrane module discussed herein may include one or more membrane envelopes 66, typically along with suitable input and output ports through which the mixed gas stream, such as reformat stream 36 or mixed gas stream 61, is delivered to the membrane module and from which the hydrogen-rich and byproduct streams are removed. In some embodiments, the membrane module may

PCT/US 01 / 40364
PEAUS 14 JAN 2002

PCT/US01/40364-14012002

include a plurality of membrane envelopes. When the membrane module includes a plurality of membrane envelopes, the module may include fluid conduits interconnecting the envelopes, such as to deliver a mixed gas stream thereto, to withdraw purified hydrogen gas therefrom, and/or to withdraw the gas that does not pass through the membranes from the membrane module. When the membrane module includes a plurality of membrane envelopes, the permeate stream, byproduct stream, or both, from a first membrane envelope may be sent to another membrane envelope for further purification.

An embodiment of a suitable screen structure 70 is shown in Figs. 7 and 8 and generally indicated at 72. Screen structure 72 includes plural screen members 73. In the illustrated embodiment, the screen members include a coarse mesh screen 74 sandwiched between fine mesh screens 76. It should be understood that the terms "fine" and "coarse" are relative terms. Preferably, the outer screen members are selected to support membranes 46 without piercing the membranes and without having sufficient apertures, edges or other projections that may pierce, weaken or otherwise damage the membrane under the operation conditions with which the membrane module is used. Because the screen structure needs to provide for flow of the permeated gas generally parallel to the membranes, it is preferable to use a relatively coarser inner screen member to provide for enhanced parallel flow conduits. In other words, the finer mesh screens provide better protection for the membranes, while the coarser mesh screen provides better flow generally parallel to the membranes.

According to the method of the present invention, an adhesive, such as a contact adhesive, is used to secure membranes 46 to the screen structure during fabrication. An example of a suitable adhesive is sold by 3M under the trade name SUPER 77. An adhesive may additionally or alternatively be used to adhere the fine mesh screens to coarse mesh screen 74 during assembly. In Fig. 7, reference numerals 78 and 80 are used to indicate respectively adhesive joining membrane 46 with screen structure 70 and individual screen members 73. It should be understood that adhesives 78 and 80 may have the same or different compositions, thicknesses and/or application methods.

The use of adhesive 78 allows the sandwiched screen structure to be retained as a unit in a selected configuration, such as the flat, planar configuration

shown in Figs. 7 and 8. The use of adhesive 80 allows the thin membranes to be firmly attached to the screen structure without any wrinkles in the membrane. It is important that these components be held flat and in close contact during assembly of the membrane module. If the membrane buckles, or if the screen structure buckles, then a wrinkle will form in the membrane during use. Similarly, if the membranes are improperly positioned relative to the screen structure, wrinkles may also occur, such as when the membrane module is pressurized. As pointed out above, wrinkles in the membrane lead to stress fractures and fatigue fractures, causing failure of the membrane module and contamination of the purified gas stream.

In practice, a light coating of contact adhesive 78 is sprayed or otherwise applied to the two opposing major surfaces of the coarse mesh screen 74 and then fine mesh screens 76 are attached, one to each major surface of the coarse screen. Adhesive 78 holds screen structure 72 together. Alternatively, the adhesive may be applied to screens 76 instead of being applied to the coarse screen. Similarly, adhesive 80 is applied between the corresponding surfaces of the fine mesh screens and hydrogen-selective membranes 46 may then be adhesively secured to the opposed surfaces of the fine mesh screens. As discussed herein, the adhesive is at least substantially, or completely, removed after fabrication of the membrane envelope and/or membrane modules so as to not interfere with the operation of the membrane envelopes.

It is within the scope of the invention that the screen members may be of similar or the same construction, and that more or less screen members may be used. It is also within the scope of the invention that any suitable supporting medium that enables permeated gas to flow in the harvesting conduit generally parallel and transverse to the membranes may be used. For example, porous ceramics, porous carbon, porous metal, ceramic foam, carbon foam, and metal foam may be used to form screen structure 70, either alone, or in combination with one or more screen members 73. As another example, fine mesh screens 76 may be formed from expanded metal instead of a woven mesh material. Preferably, screen structure 70 is formed from a corrosion-resistant material that will not impair the operation of the membrane module and devices with which the membrane module is used. Examples of suitable materials for metallic screen members include stainless steels, titanium and alloys thereof, zirconium and alloys thereof, corrosion-resistant alloys, including Inconel™

PC..JS 01 / 40364
IPERUS 14 JAN 2002

PCT/US01/40364 14012002

alloys, such as 800HTM, and HastelloyTM alloys, and alloys of copper and nickel, such as MonelTM.

An example of an expanded metal screen member is shown in Fig. 9 and generally indicated at 82. Expanded metal sheets include a latticework 83 of metal that defines a plurality of apertures 84 through which permeated gas may flow. Although other processes may be used, expanded metal sheets may be formed from scoring a sheet of metal and then stretching the metal to provide apertures, such as apertures 84 at the scores. It should be understood that the expanded metal screen member has been schematically illustrated in Fig. 9, and that the actual shape of the apertures may vary and will often have shapes that generally resemble diamonds, parallelograms or other geometric shapes, for example as shown in Fig. 12. The sheet may also include a solid perimeter region 86, which is advantageous because it is free from projections, burrs, or other wire ends that may be present in woven mesh screen members and which may pierce or otherwise damage the hydrogen-selective membranes. Although only a portion of expanded metal screen member 82 is shown in Fig. 9, the perimeter region 86 of the screen member may extend all the way around the screen member. Alternatively, only the perimeter regions that contact membranes 46 may be solid surfaces.

All of the foregoing metallic screen compositions may include a coating 85 on surface 71 (such as shown in Fig. 6). Examples of suitable coatings include aluminum oxide, tungsten carbide, tungsten nitride, titanium carbide, titanium nitride, and mixtures thereof. These coatings are generally characterized as being thermodynamically stable with respect to decomposition in the presence of hydrogen. Suitable coatings are formed from materials, such as oxides, nitrides, carbides, or intermetallic compounds, that can be applied as a coating and which are thermodynamically stable with respect to decomposition in the presence of hydrogen under the operating parameters (temperature, pressure, etc.) in which the membrane module will be subjected. Alternatively, the coating may be applied to an expanded metal screen member that is used in place of a fine mesh screen, in which case the coating would be applied to at least the surface of the expanded mesh that will contact the hydrogen-selective membrane 46. Suitable methods for applying such coatings to the screen or expanded metal screen member include chemical vapor deposition, sputtering, thermal evaporation, thermal spraying, and, in the case of at least

01/40364

PEAUS 14 JAN 2002

PET. US 01. 40364. 14012002

aluminum oxide, deposition of the metal (e.g., aluminum) followed by oxidation of the metal to give aluminum oxide. In at least some embodiments, the coatings may be described as preventing intermetallic diffusion between the hydrogen-selective membranes and the screen structure.

5 Preferably, the screen structure and membranes are incorporated into a membrane module that includes frame members 88 that are adapted to seal, support and/or interconnect the membrane envelopes for use in fuel processing systems, gas purification systems, and the like. Fine mesh metal screen 76 fits within permeate frame 90. Expanded metal screen member 86 may either fit within permeate frame 90
10 or extend at least partially over the surface of permeate frame 90. Examples of suitable frame members 88 include supporting frames and/or gaskets. These frames, gaskets or other support structures may also define, at least in part, the fluid conduits that interconnect the membrane envelopes in an embodiment of membrane module 44 that contains two or more membrane envelopes. Examples of suitable gaskets are
15 flexible graphite gaskets, although other materials may be used, such as depending upon the operating conditions in which a particular membrane module is used.

 An example of a membrane envelope 66 that includes frame members 88 is shown in Fig. 10. As shown, screen structure 70 is placed in a permeate frame 90 that forms a portion of membrane module 44. The screen structure and frame 90
20 may collectively be referred to as a screen frame or permeate frame 91. Permeate gaskets 92 and 92' are attached to permeate frame 90, preferably but not necessarily, by using another thin application of adhesive. Next, membranes 46 are attached to screen structure 70 using a thin application of adhesive, such as by spraying or otherwise applying the adhesive to either or both of the membrane and/or screen
25 structure. Care should be taken to ensure that the membranes are flat and firmly attached to the corresponding screen member 73. Finally, feed plates, or gaskets, 94 and 94' are optionally attached, such as by using another thin application of adhesive. The resulting membrane assembly is then stacked with feed, or end, plates to form membrane module 44. Optionally, two or more membrane envelopes may be stacked
30 between the end plates.

 Optionally, each membrane 46 may be fixed to a frame 104, such as a metal frame and such as shown in Fig. 11. If so, the membrane is fixed to the frame, for instance by ultrasonic welding or another suitable attachment mechanism, and the

membrane-frame assembly is then attached to screen structure 70 using adhesive. Other examples of attachment mechanisms achieve gas-tight seals between plates forming membrane envelope 66, as well as between the membrane envelopes, include one or more of brazing, gasketing, and welding. The membrane and attached frame may
5 collectively be referred to as a membrane plate 96.

For purposes of illustration, the geometry of fluid flow through membrane envelope 66 is described with respect to the embodiment of envelope 66 shown in Fig. 10. As shown, a mixed gas stream, such as reformat stream 36, is delivered to the membrane envelope and contacts the outer surfaces 97 of membranes
10 46. The hydrogen gas that permeates through the membranes enters harvesting conduit 69, which is formed between the permeate faces 68 of the membranes. The harvesting conduit is in fluid communication with conduits 100 through which the permeate stream may be withdrawn from the membrane envelope. The portion of the mixed gas stream that does not pass through the membranes flows to a conduit 98
15 through which this gas may be withdrawn as byproduct stream 40. In Fig. 10, a single byproduct conduit 98 is shown, while in Fig. 11 a pair of conduits 98 and 102 are shown to illustrate that any of the conduits described herein may alternatively include more than one fluid passage. It should be understood that the arrows used to indicate the flow of streams 40 and 42 have been schematically illustrated, and that the
20 direction of flow through conduits 98, 100 and 102 may vary, such as depending upon the configuration of a particular membrane module.

In Fig. 12, another example of a suitable membrane envelope 66 is shown. For purposes of illustration, envelope 66 is shown having a generally rectangular form. The envelope of Fig. 12 also provides another example of a
25 membrane envelope having a pair of byproduct conduits 98 and 102 and a pair of hydrogen conduits 100. As shown, envelope 66 includes gaskets or spacer plates 94 as the outer most plates in the stack. Generally, each of spacer plates includes a frame 106 that defines an inner open region 108. Each inner open region 108 couples laterally to conduits 98 and 102. Conduits 100, however, are closed relative to open region 108,
30 thereby isolating the hydrogen-rich stream 42. Membrane plates 96 lie adjacent and interior to plates 94. Membrane plates 96 each include as a central portion thereof a hydrogen-selective membrane 46, which may be secured to an outer frame 104 that is shown for purposes of illustration. In plates 96, all of the ports are closed relative to

membrane 46. Each membrane lies adjacent to a corresponding one of open regions 108, i.e., adjacent to the flow of mixed gas arriving to the envelope. This provides opportunity for hydrogen to pass through the membrane, with the remaining gases, i.e., the gases forming byproduct stream 40, leaving open region 108 through conduit 102.

5 Screen plate 91 lies intermediate membrane plates 96, i.e., on the interior or permeate side of each of membranes 46. Screen plate 91 includes a screen structure 70. Conduits 98 and 102 are closed relative to the central region of screen plate 91, thereby isolating the byproduct stream 40 and the reformate-rich flow 36 from hydrogen-rich stream 42. Conduits 100 are open to the interior region of screen plate 91. Hydrogen, having

10 passed through the adjoining membranes 46, travels along and through screen structure 70 to conduits 100 and eventually to an output port as the hydrogen-rich stream 42.

As discussed, membrane module 44 may include one or more membrane envelopes in which the membranes have been adhesively bonded to the screen structure, and/or in which the screen structure includes two or more screen

15 members 83 that are adhesively bonded together. Typically, the membrane module further includes end plates having input and output ports through which the mixed gas, product (or hydrogen-rich) and byproduct streams are removed from the membrane module. An example of a suitable membrane module is shown in Fig. 13 in the form of a plate membrane module. As shown, the module contains end plates

20 110 between which one or more membrane envelopes 66 are contained. In the illustrated embodiment, three membrane envelopes are shown for purposes of illustration, but it should be understood that more or less envelopes may be used. The membrane envelopes are in fluid communication with at least one of the end plates, through which the mixed gas stream is delivered and from which the byproduct 40

25 and hydrogen-rich 42 streams are removed.

As shown in the illustrative embodiment of Fig. 13, one of the end plates contains a reformate input port 112 for a mixed gas stream, such as reformate stream 36 or any of the other feeds to the membrane modules discussed herein. The end plates further include a pair of exit ports 114 for permeate, or hydrogen-rich,

30 stream 42 and an exit port 116 for byproduct stream 40. It should be understood that the number and sizing of the ports for each stream may vary, and that at least one of the ports may be contained on the other end plate or elsewhere on the membrane module, such as on a housing 118 between the end plates, such as shown in Fig. 15.

As shown, the membrane envelopes include conduits 98, 100 and 102 that establish fluid communication with the input and exit ports and between the membrane envelopes. When membrane envelopes 66 are stacked, these various ports align and provide fluid conduits.

5 In operation, reformat gas is introduced to the membrane module through port 112 and is delivered to the membrane envelopes. Hydrogen gas that passes through the hydrogen-selective membranes 46 flows to conduits 100 and is removed from the membrane module through ports 114. The rest of the reformat gases, namely the portion that does not pass through the hydrogen-selective
10 membranes, flows to conduit 102 and is removed from the membrane module as byproduct stream 40 through port 116.

It should be understood that the geometry of the frame members, gaskets, membranes and screen members shown in the Figs. 7-13 are provided as illustrative examples, and it should be understood that these components may be of
15 any suitable shape. For example, illustrations of circular and rectangular plate membrane envelopes are illustrated in Figs. 10-13 for purposes of illustration. Other shapes, and other configurations, such as tubular configurations, are also within the scope of the present invention. Similarly, the configuration and orientation of the passages through the gaskets and plates may vary, depending upon the particular
20 application with which the membrane module will be used.

Membrane modules containing the palladium alloy membranes that are adhesively bonded to screen structure 70 preferably are subjected to oxidizing conditions prior to initial operation of the membrane module to remove the adhesive. If adhesive is not fully removed prior to operation, the carbon residue from the
25 adhesive can alloy with the palladium-alloy membrane and cause a decline in hydrogen permeability. In extreme cases, carbon alloying with the palladium-alloy membrane can form a brittle alloy that physically fails under operating conditions.

The objective of the oxidative conditioning is to burn out the adhesive without excessively oxidizing the palladium-alloy membrane. One set of suitable
30 conditions using the above membrane compositions and adhesive is to heat the membrane module to 200° C while passing air over both the feed side and the permeate side of the membrane. A preferred method is to heat the membrane module to 200° C while the feed side is pressurized to a pressure greater than the permeate

side of the membranes using a slow purge of air (>1 mL/min). Pressures in the range of approximately 50 psig to approximately 200 psig have proven effective. Air at approximately ambient pressure is passed over the permeate side of the membrane at a rate >1 mL/min. These conditions are maintained for approximately 15-25 hours.

5 Then the temperature is increased to 400° C, while maintaining air pressure and flow rate over the feed and permeate sides of the membranes. The temperature is held at 400° C for approximately 2-5 hours. After completing this oxidative conditioning of the membrane module, the adhesive has been burned out of the membrane module and the module is ready to accept a hydrogen-containing feed stream to be purified.

10 Experiments have shown that these methods result in membrane modules containing membranes that are free of wrinkles and without excessive carbon contamination.

It should be understood that the conditions described above were presented to provide an illustrative example and that the operating conditions may vary. For example, different conditions may be used because of such factors as

15 different membrane compositions, different membrane thicknesses, and different adhesives. Similarly, the invented method using an adhesive to secure hydrogen-selective membranes on one or more support screens may be used with purification assemblies other than the fuel processing assemblies described herein and in the incorporated patent applications.

20 An example of a fuel processor 12 containing a membrane module 44 according to the present invention is shown in Fig. 14. In the illustrated embodiment, fuel processor 12 is shown as a steam reformer 30 that contains reforming catalyst 34. Alternatively, reformer 30 may be an autothermal reformer that contains an autothermal reforming catalyst bed. It should be understood that fuel processor 12

25 may be any device adapted to produce hydrogen gas, such as those discussed herein.

In the embodiment of steam reformer 30 shown in Fig. 14, a feed stream 16 is delivered to a vaporization region 150, which as shown contains a vaporization coil 151 in which the feed stream is vaporized. For a steam reformer, a suitable feed stream includes water and a carbon-containing feedstock, such as one or

30 more alcohols or hydrocarbons. When the carbon-containing feedstock is miscible with water, the feedstock and water may be mixed and then vaporized. When the carbon-containing feedstock is not miscible with water, the water is typically vaporized and then mixed with the carbon-containing feedstock. In the illustrated

embodiment, vaporization coil 151 is contained within the shell 31 of the reformer. It is within the scope of the invention that the vaporization region (and coil) may be located external the shell of the fuel processor, such as extending around the shell or otherwise located outside of the shell.

5 The vaporized feed stream is then delivered to hydrogen-producing region 32, which in the context of a reformer, contains at least one reforming catalyst bed. The reformat stream, which is a mixed gas stream containing hydrogen gas and other gases, 36 is then delivered to membrane module 44, which separates the mixed gas stream into hydrogen-rich stream 42 and byproduct stream 40, as discussed above.
10 The illustrated reformer demonstrates that the byproduct stream may be used to provide some or all of the fuel for the reformer's heating assembly 152. Heating assembly 152 includes a heating element 153, which in the illustrated embodiment takes the form of a spark plug. Examples of other suitable heating elements include glow plugs, pilot lights, combustion catalysts, resistance heaters, and combinations
15 thereof, such as a glow plug in combination with a combustion catalyst.

 Heating assembly 152 consumes a fuel stream 154, which may be a combustible fuel stream or an electric current, depending upon the type of heating element used in the heating assembly. In the illustrated embodiment, the heating assembly forms part of a combustion chamber, or region, 155, and the fuel stream
20 includes a combustible fuel and air from an air stream 156. The fuel may come from an external source, such as schematically illustrated at 157, or may be at least partially formed from the byproduct stream 40 from membrane module 44. It is within the scope of the invention that at least a portion of the fuel stream may also be formed from product hydrogen stream 14. In the illustrated embodiment, the exhaust from
25 combustion region 155 flows through heating conduits 158 in reforming region 32 to provide additional heating to the reforming region. Conduits 158 may take a variety of forms, including finned tubes and spirals, to provide sufficient surface area and desirable uniform distribution of heat throughout reforming region 32.

 In Fig. 15, another illustrative example of a steam reformer containing
30 a membrane module 44 constructed according to the present invention is shown. As shown, the reforming region includes a plurality of reforming catalyst tubes 162 that contain reforming catalyst 34. The vaporized feed stream from vaporization region 150 is delivered to tubes 162 via a manifold 172 that distributes the feed stream

between reforming catalyst tubes. As shown in dashed lines in Fig. 15, the manifold may alternatively be located external shell 31 to enable access to the manifold from external the shell, such as to adjust the relative distribution of the vaporized feed stream between the reforming catalyst tubes. Similarly, portions 160 of the reforming catalyst tubes are also shown extending beyond shell 31.

The steam reformer of Fig. 15 also provides an example of a fuel processor 12 in which the byproduct stream may be either used as a portion of fuel stream 154 for combustion region 155, vented (such as through pressure-relief valve assembly 164), or delivered through fluid conduit 166 for storage or use outside of fuel processor 12. Also shown in Fig. 10 are flow regulators 168 for heat produced by heating assembly 152 in combustion region 155. In the illustrated embodiment, regulators 168 take the form of apertures in a combustion manifold 170. The apertures regulate the path along which combustion exhaust travels from combustion region 155 and through reforming region 32. Examples of suitable placement of the apertures include one or more apertures distal heating assembly 152, and a plurality of apertures distributed along the length of manifold 170. When a distribution of spaced-apart apertures is used, the apertures may be evenly spaced, or the openings may be more prevalent distal the burner. Similarly, the size of the apertures may be uniform, or may vary, such as using larger apertures away from heating assembly 152.

It should be understood that the steam reformers shown in Figs. 14 and 15 are shown and described for purposes of illustration and should not be construed as providing exclusive embodiments of fuel processors or steam reformers with which the invented membrane modules may be used. Instead, the structure and components of reformers and fuel processors containing membrane modules according to the invention may vary.

Industrial Applicability

The present invention is applicable in any device in which a stream containing hydrogen gas is purified to produce a purified hydrogen stream. The invention is similarly applicable to fuel processing systems in which hydrogen gas is produced from a feed stream and subsequently purified, such as for delivery to a fuel cell stack or other hydrogen-consuming device.

It is believed that the disclosure set forth above encompasses multiple distinct inventions with independent utility. While each of these inventions has been

disclosed in its preferred form, the specific embodiments thereof as disclosed and illustrated herein are not to be considered in a limiting sense as numerous variations are possible. The subject matter of the inventions includes all novel and non-obvious combinations and subcombinations of the various elements, features, functions and/or properties disclosed herein. Similarly, where the claims recite “a” or “a first” element or the equivalent thereof, such claims should be understood to include incorporation of one or more such elements, neither requiring nor excluding two or more such elements.

It is believed that the following claims particularly point out certain combinations and subcombinations that are directed to one of the disclosed inventions and are novel and non-obvious. Inventions embodied in other combinations and subcombinations of features, functions, elements and/or properties may be claimed through amendment of the present claims or presentation of new claims in this or a related application. Such amended or new claims, whether they are directed to a different invention or directed to the same invention, whether different, broader, narrower or equal in scope to the original claims, are also regarded as included within the subject matter of the inventions of the present disclosure.

THE EMBODIMENTS OF THE INVENTION IN WHICH AN EXCLUSIVE PROPERTY OR PRIVILEGE IS CLAIMED ARE DEFINED AS FOLLOWS:

1. A hydrogen purification assembly, comprising:

a membrane module adapted to receive a mixed gas stream containing hydrogen gas and other gases, a product output through which a product stream is removed from the membrane module, and a byproduct output through which a byproduct stream is removed from the membrane module, wherein the product stream contains at least substantially hydrogen gas and further wherein the byproduct stream contains at least a substantial portion of the other gases; and

at least one membrane envelope comprising:

a pair of hydrogen-selective membrane regions, wherein each membrane region has a feed side and a permeate side, wherein the membrane regions are spaced-apart from each other with their permeate sides facing each other and defining a harvesting conduit extending therebetween, wherein the harvesting conduit is in fluid communication with the product output to enable gas passing through the membrane regions into the harvesting conduit to be withdrawn from the membrane module through the product output, and further wherein the feed sides are in fluid communication with the mixed gas stream; and

a support within the harvesting conduit and adapted to support the permeate sides of the membrane regions, wherein the support includes a pair of generally opposed contact surfaces that are adapted

to respectively support the permeate sides of the pair of membrane regions, and further wherein the contact surfaces are selected from the group consisting of contact surfaces that include a coating adapted to prevent intermetallic diffusion between the contact surfaces and the membrane regions and contact surfaces that are formed from an expanded metal material.

2. The assembly of claim 1, wherein the coating is adapted to be thermodynamically stable with respect to decomposition in the presence of hydrogen.
3. The assembly of claim 2, wherein the coating is adapted to be thermodynamically stable with respect to decomposition in the presence of hydrogen at temperatures less than approximately 700° C.
4. The assembly of claim 3, wherein the coating is adapted to be thermodynamically stable with respect to decomposition in the presence of hydrogen at temperatures less than approximately 400° C.
5. The assembly of any one of claims 2-4, wherein the coating is adapted to be thermodynamically stable with respect to decomposition in the presence of hydrogen at pressures less than approximately 1000 psi.
6. The assembly of claim 5, wherein the coating is adapted to be thermodynamically stable with respect to decomposition in the presence of hydrogen at pressures less than approximately 500 psi.
7. The assembly of any one of claims 1-6, wherein the coating is formed from at least one of the group consisting of oxides, nitrides, carbides, and intermetallic compounds.

8. The assembly of claim 7, wherein the coating is selected from the group consisting of aluminum oxide, tungsten carbide, tungsten nitride, titanium carbide, titanium nitride, and mixtures thereof.
9. The assembly of any one of claims 1-8, wherein the coating is applied to the surfaces by at least one of chemical vapor deposition, sputtering, thermal evaporation, thermal spraying, and deposition followed by oxidation.
10. The assembly of any one of claims 1-9, wherein the support is adapted to permit flow of gas both parallel and transverse to the permeate sides of the membrane regions.
11. The assembly of any one of claims 1-10, wherein the support defines a gas stream path through the harvesting conduit, with the stream path extending parallel and transverse to the permeate sides of the membrane regions.
12. The assembly of any one of claims 1-11, wherein the support is formed from a porous material.
13. The assembly of any one of claims 1-12, wherein the contact surfaces are formed from an expanded metal material.
14. The assembly of any one of claims 1-13, wherein the membrane regions are adhesively bonded to the contact surfaces during fabrication of the membrane envelope and thereafter subjected to oxidizing conditions to remove the adhesive after fabrication of the membrane envelope.

-25-

15. The assembly of any one of claims 1-14, wherein the support includes a plurality of screen members.
16. The assembly of claim 15, wherein the plurality of screen members are adhesively bonded together during fabrication of the membrane envelope.
17. The assembly of any one of claims 15 and 16, wherein the plurality of screen members includes an inner screen member and a pair of outer screen members that form the generally opposed surfaces to which the hydrogen-selective membrane regions are adhesively mounted during fabrication of the membrane envelope.
18. The assembly of claim 17, wherein the inner screen member is coarser than the outer screen members.
19. The assembly of any one of claims 15-18, wherein at least one of the screen members is formed of expanded metal.
20. The assembly of any one of claims 1-19, wherein each hydrogen-selective membrane region is formed from at least one of palladium and a palladium alloy.
21. The assembly of claim 20, wherein each hydrogen-selective membrane region is formed from an alloy containing palladium and copper.
22. The assembly of any one of claims 1-21, wherein the membrane module includes a plurality of membrane envelopes.
23. The assembly of claim 22, wherein the membrane module includes end plates between which the plurality of membrane envelopes are supported, an inlet port through which the mixed gas stream is received by the membrane module, a product

outlet port through which the product stream is withdrawn from the membrane module, and a byproduct port through which the byproduct stream is withdrawn from the membrane module.

24. The assembly of claim 23, wherein the membrane module includes a plurality of gas transport conduits adapted to selectively deliver the mixed gas stream to the feed sides of the membrane regions, remove the product stream from the harvesting conduits, and remove the byproduct stream from the membrane module.
25. The assembly of any one of claims 22-24, wherein each membrane envelope includes an input through which at least a portion of the mixed gas stream is delivered to the feed sides of the membrane regions, a byproduct output through which the portion of the mixed gas stream that does not pass through the hydrogen-selective membrane regions is removed from the membrane envelope, and a product output through which the portion of the mixed gas stream that permeates through the hydrogen-selective membrane regions is removed from the harvesting conduit.
26. The assembly of claim 25, wherein the corresponding inputs, product outputs and byproduct outputs of the plurality of membrane envelopes are in fluid communication with each other to respectively form an inlet conduit, a product conduit and a byproduct conduit.
27. The assembly of any one of claims 1-26, in combination with a hydrogen-producing device adapted to produce the mixed gas stream.
28. The assembly of claim 27, wherein the assembly is at least partially contained within the hydrogen-producing device.

29. The assembly of claim 28, wherein the assembly is entirely contained within the hydrogen-producing device.
30. The assembly of any one of claims 27-29, wherein the hydrogen-producing device includes a hydrogen-producing region that is adapted to receive a feed stream and to produce the mixed gas stream therefrom.
31. The assembly of claim 30, wherein the hydrogen-producing region is a steam reforming region that includes at least one reforming catalyst bed and the feed stream includes water and a carbon-containing feedstock.
32. The assembly of any one of claims 1-31, in combination with a polishing catalyst bed that includes a methanation catalyst and which is adapted to receive the product stream.
33. The assembly of any one of claims 1-32, in combination with a hydrogen-consuming device adapted to receive at least a portion of the product stream.
34. The assembly of claim 33, wherein the hydrogen-consuming device includes a fuel cell stack.
35. The assembly of any one of claims 33-34, wherein the hydrogen-consuming device includes a burner.
36. A method for forming a hydrogen-selective membrane module, the method comprising:

providing a pair of hydrogen-selective metal membranes having feed sides and permeate sides;

providing a support including outer surfaces through which hydrogen gas may flow;

adhesively mounting the permeate side of one of the hydrogen-selective metal membranes to one of the outer surfaces of the support and adhesively mounting the permeate side of another of the hydrogen-selective metal membranes to the other of the outer surfaces of the support to form a membrane envelope having a harvesting conduit extending between the permeate sides of the hydrogen-selective metal membranes;

placing the membrane envelope in a membrane module having a pair of end plates;
and

subjecting the membrane module to oxidizing conditions to remove at least a substantial portion of the adhesive.

37. The method of claim 36, wherein the subjecting step includes heating the membrane module while passing air over and through the membrane envelope.
38. The method of any one of claims 36-37, wherein the subjecting step includes maintaining the feed sides of the membranes at a greater pressure than the permeate sides.
39. The method of any one of claims 36-38, wherein the subjecting step includes heating the membrane module at a first temperature for a first time interval and then heating the membrane module at a second temperature for a second time interval, and further wherein the second temperature is greater than the first temperature.

40. The method of any one of claims 36-39, further comprising repeating the providing and adhesively mounting steps a plurality of times prior to the subjecting step.
41. The method of any one of claims 36-40, wherein the support includes a plurality of screen members.
42. The method of claim 41, wherein the method further includes adhesively mounting at least a first and a second screen member together to form the support.
43. The method of any one of claims 41-42, wherein at least one of the screen members is formed from an expanded metal material.
44. The method of any one of claims 36-43, wherein prior to the adhesively mounting step, the method further includes applying to the outer surfaces of the support a coating that is adapted to prevent intermetallic diffusion between the outer surfaces and the membranes.
45. The method of claim 44, wherein the coating is adapted to be thermodynamically stable in the presence of hydrogen.
46. A membrane module produced according to the method of any one of claims 36-44.

Fig. 1

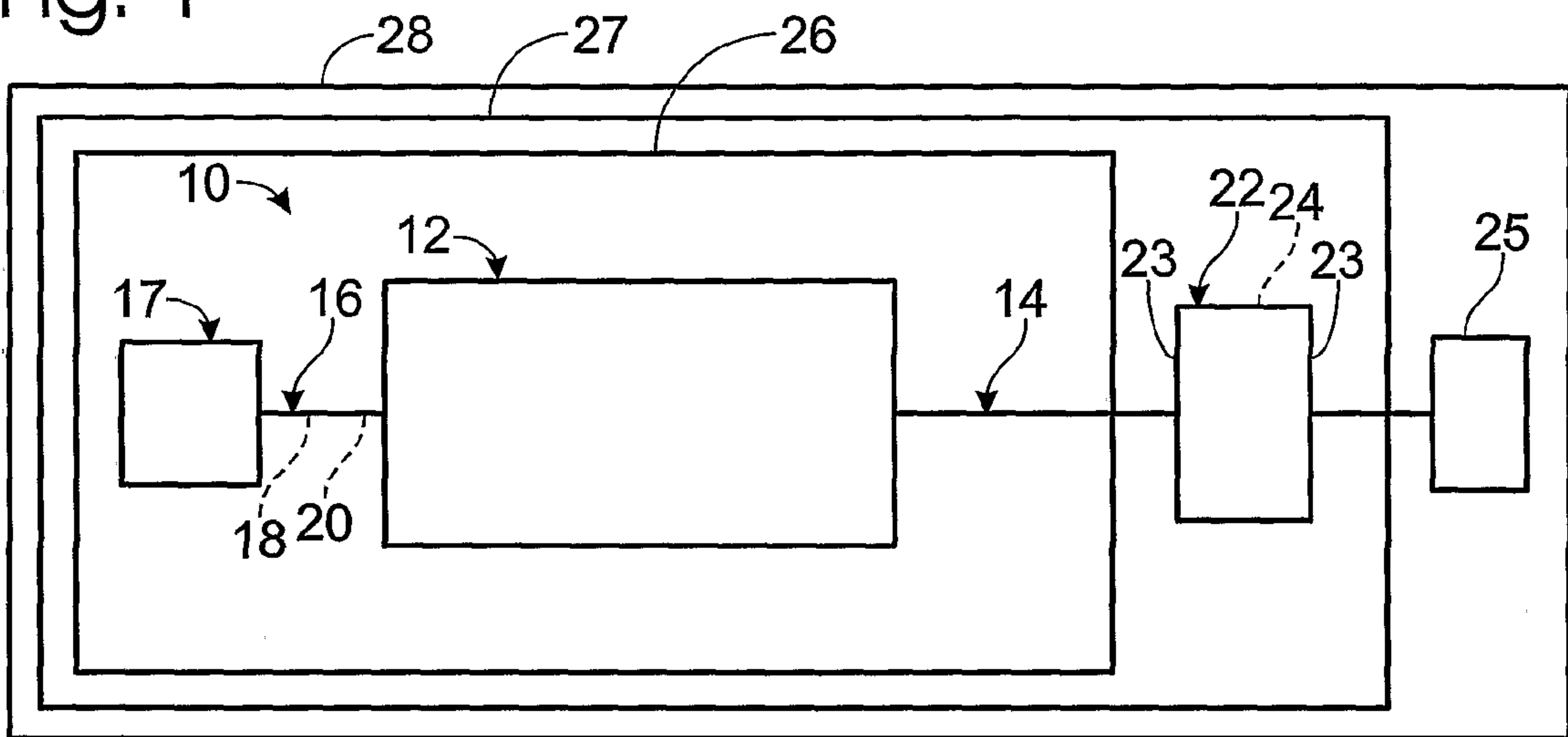

Fig. 2

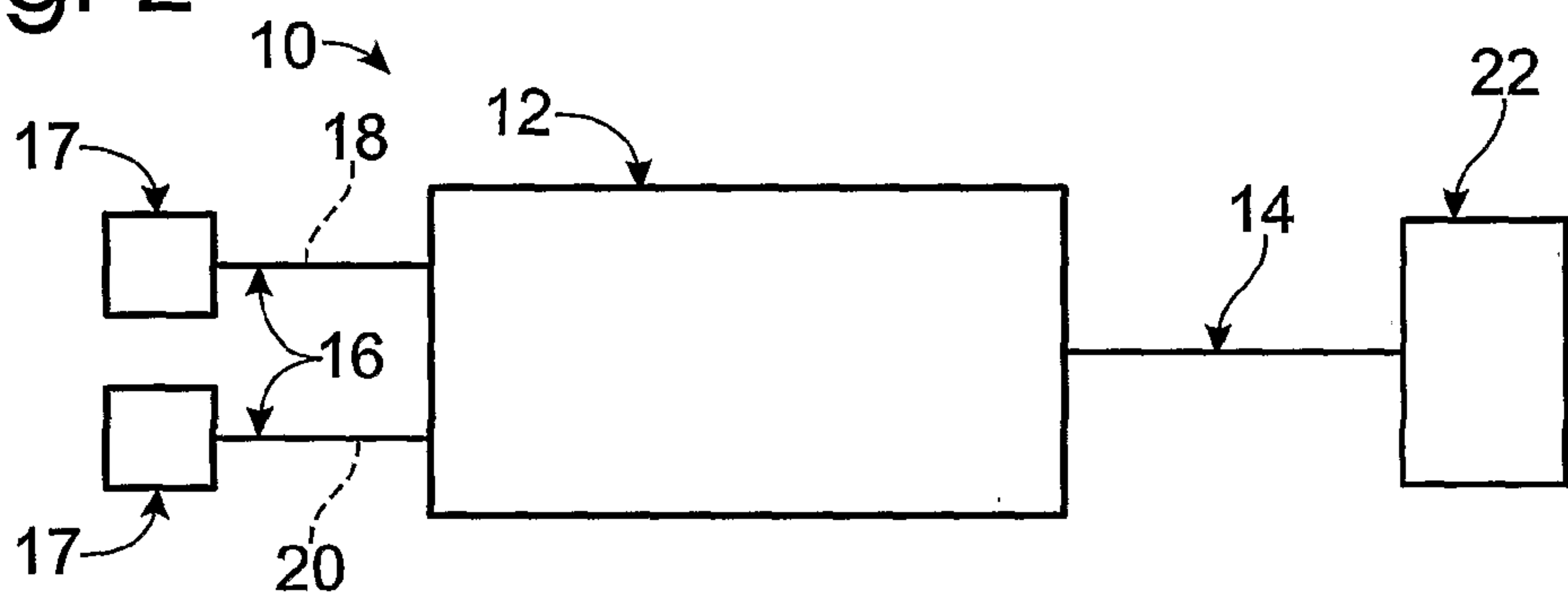

Fig. 3

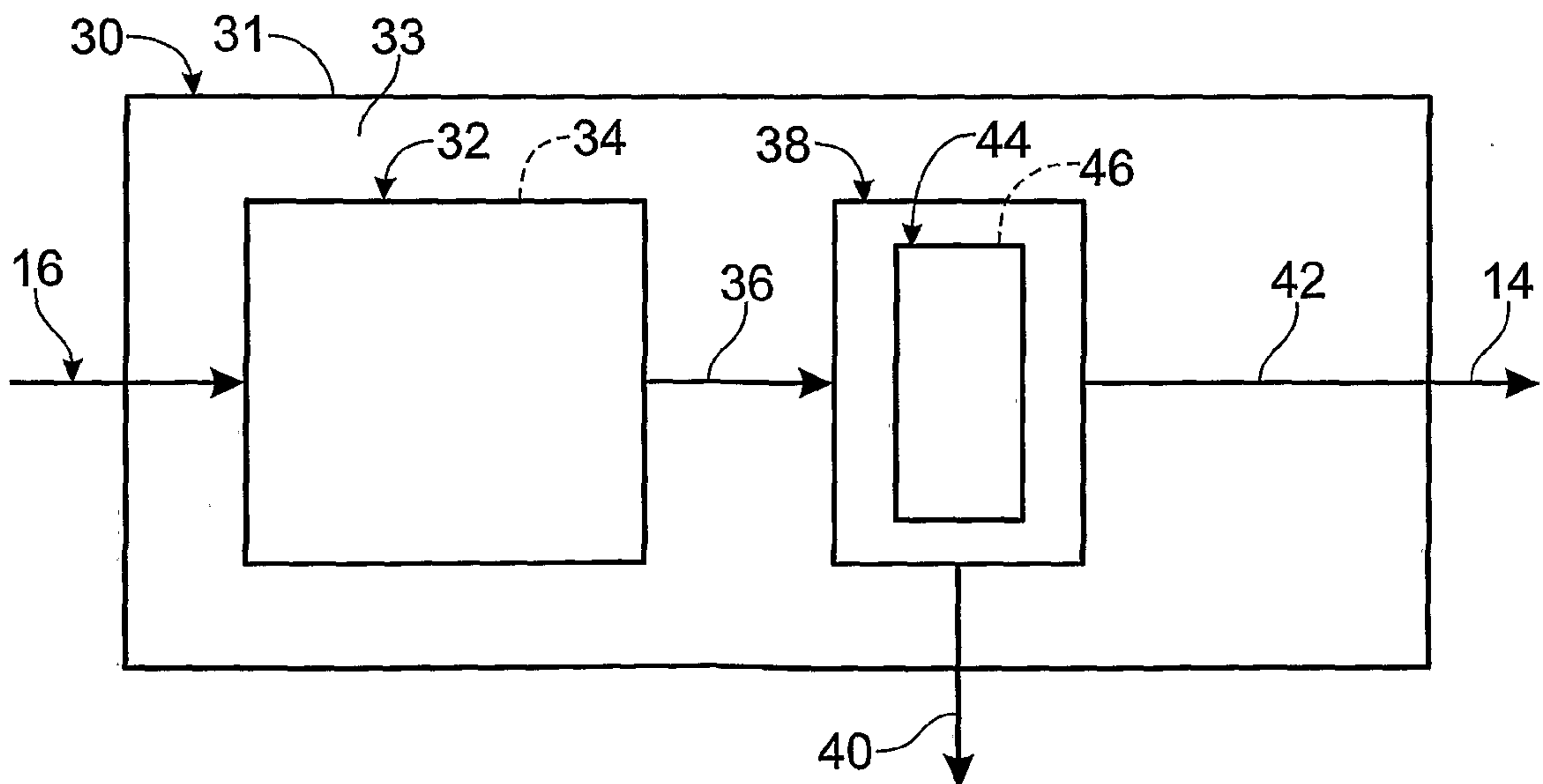

Fig. 4

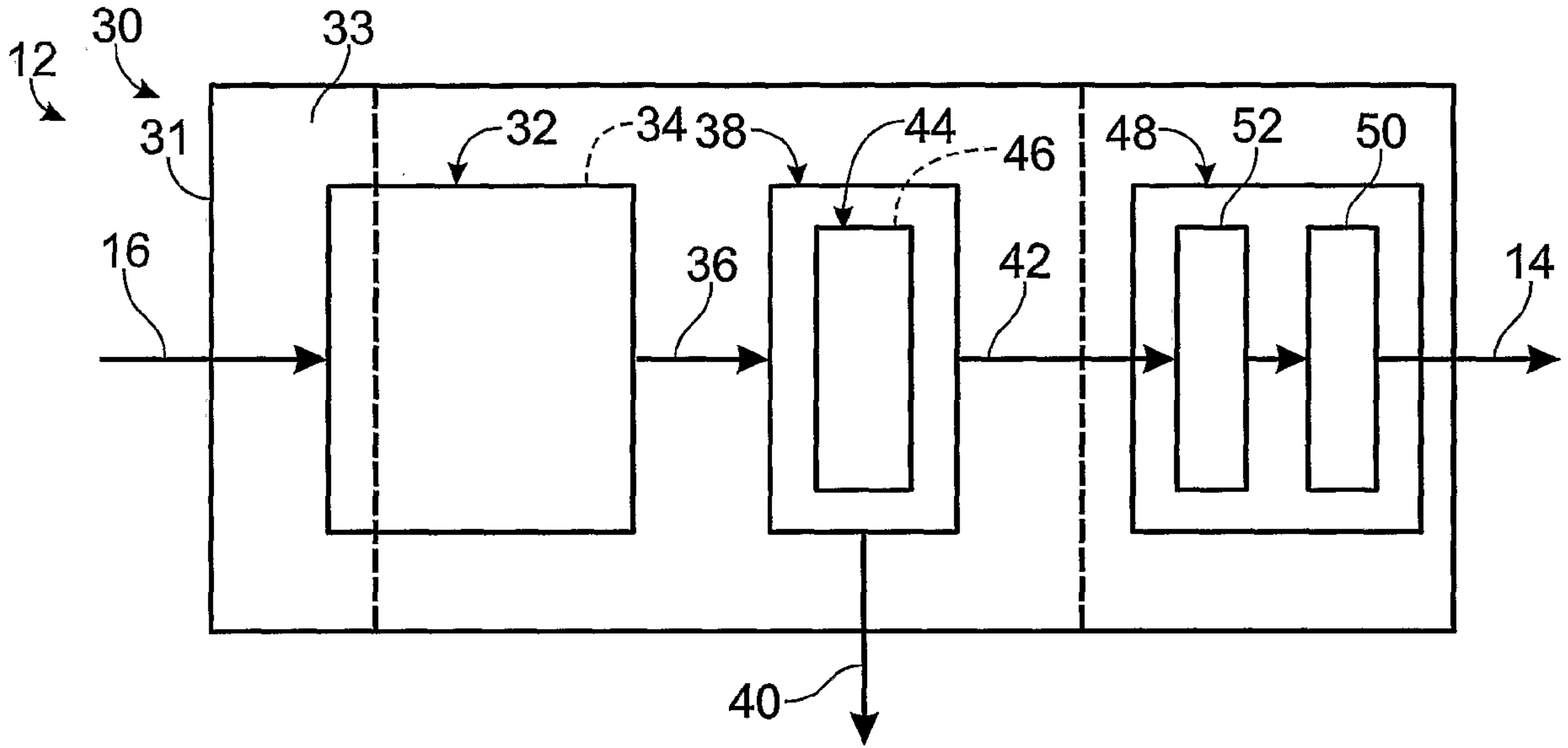

Fig. 5

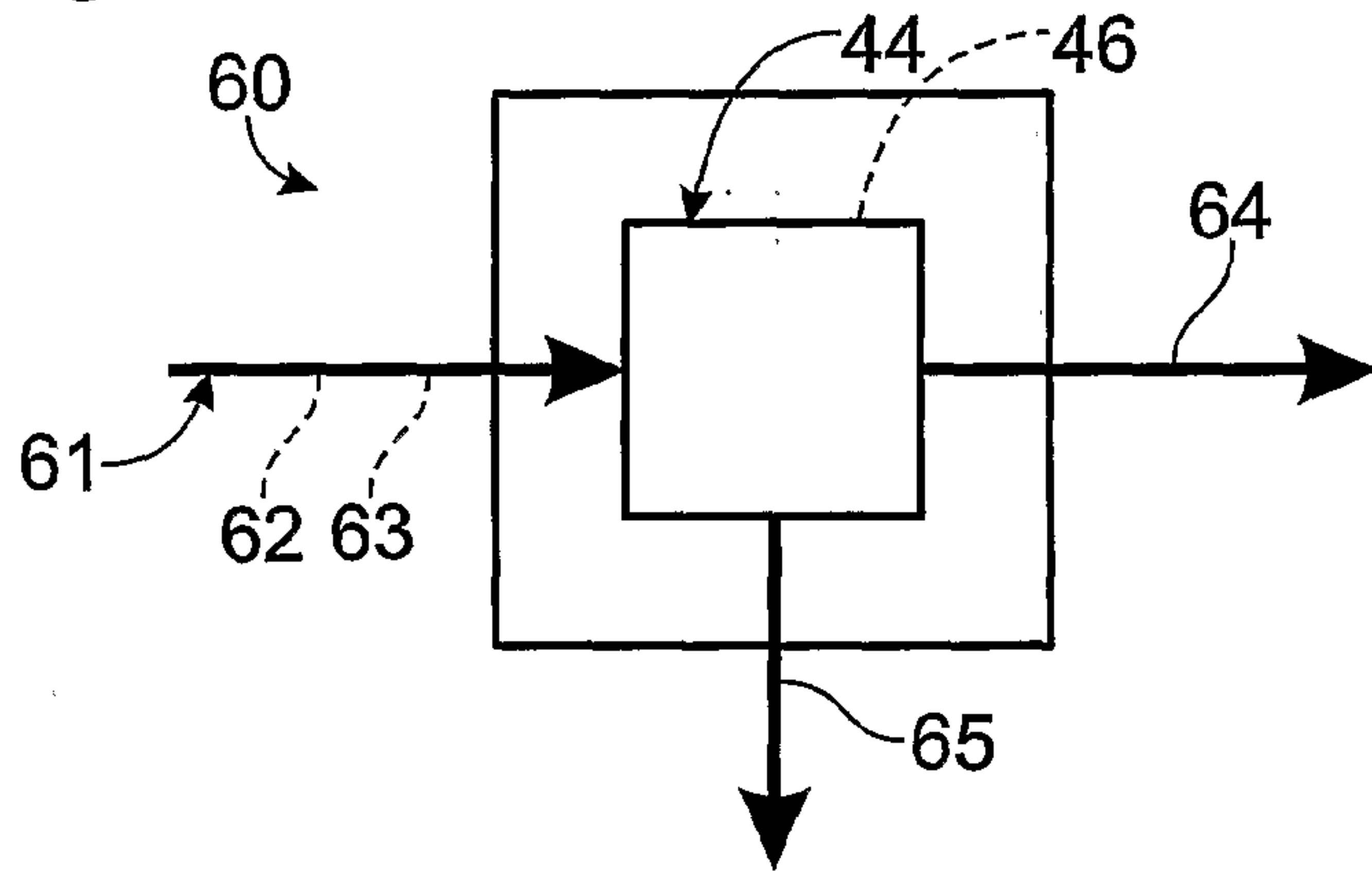
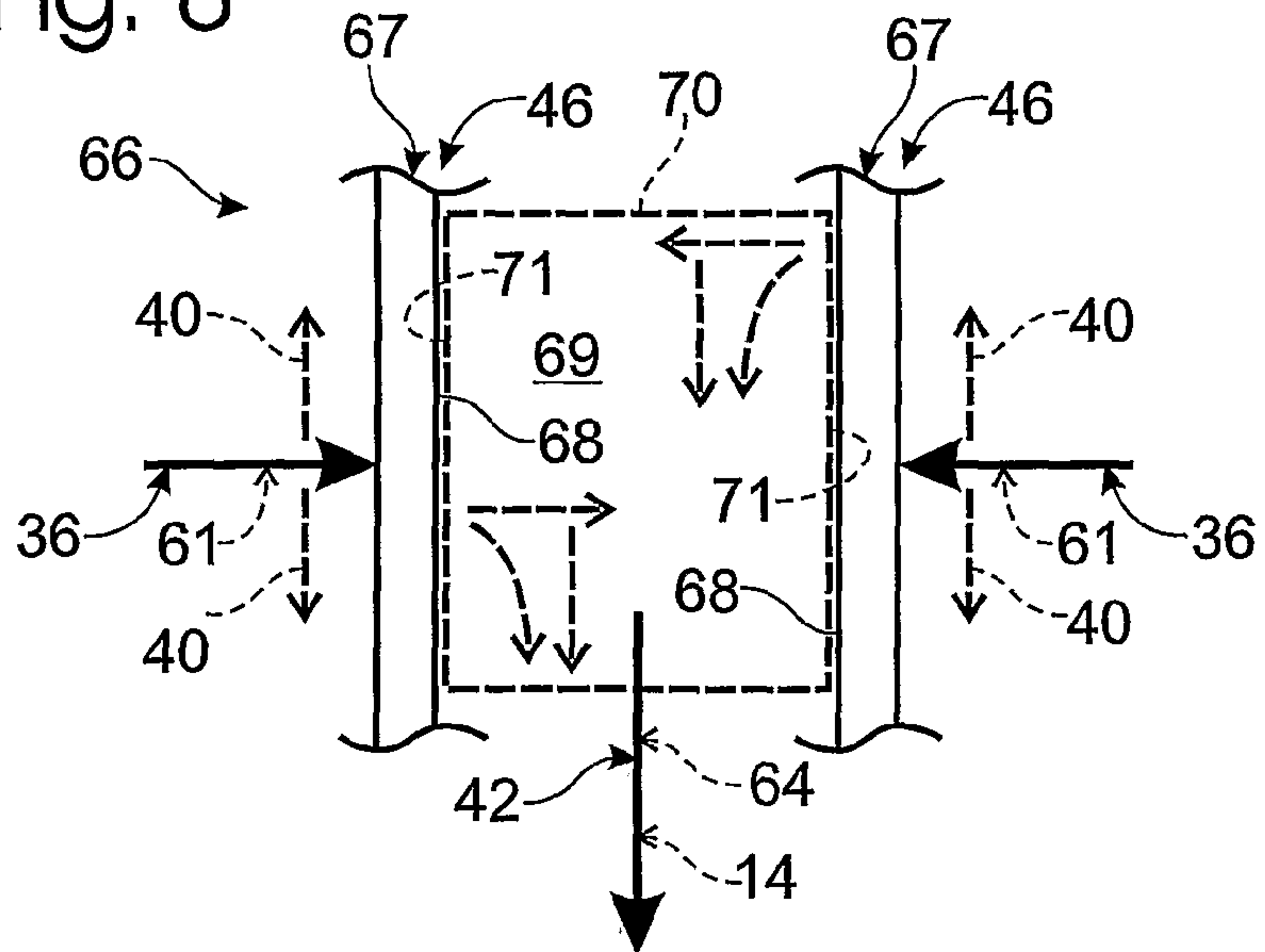

Fig. 6



3/9

Fig. 7

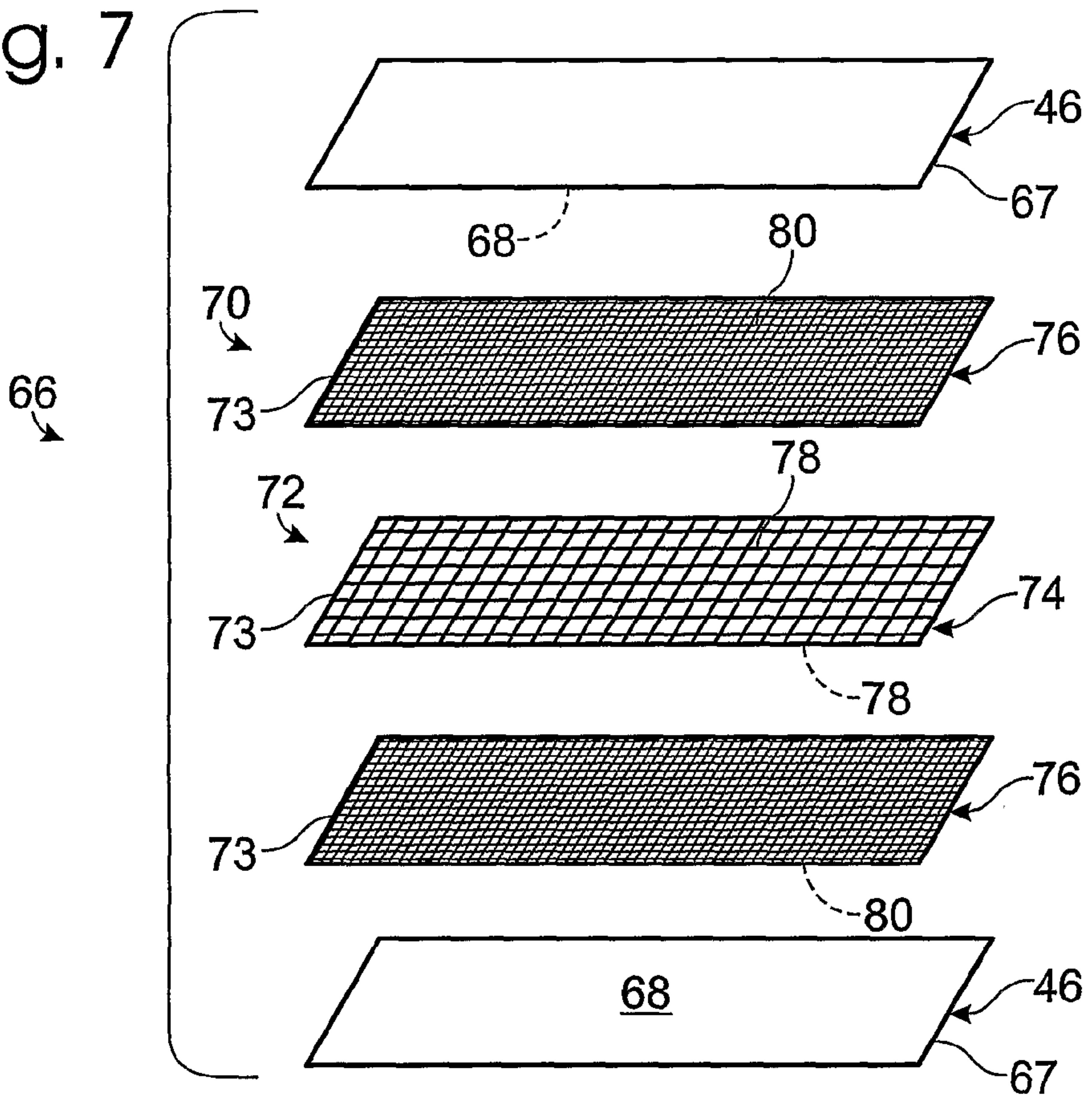

Fig. 8

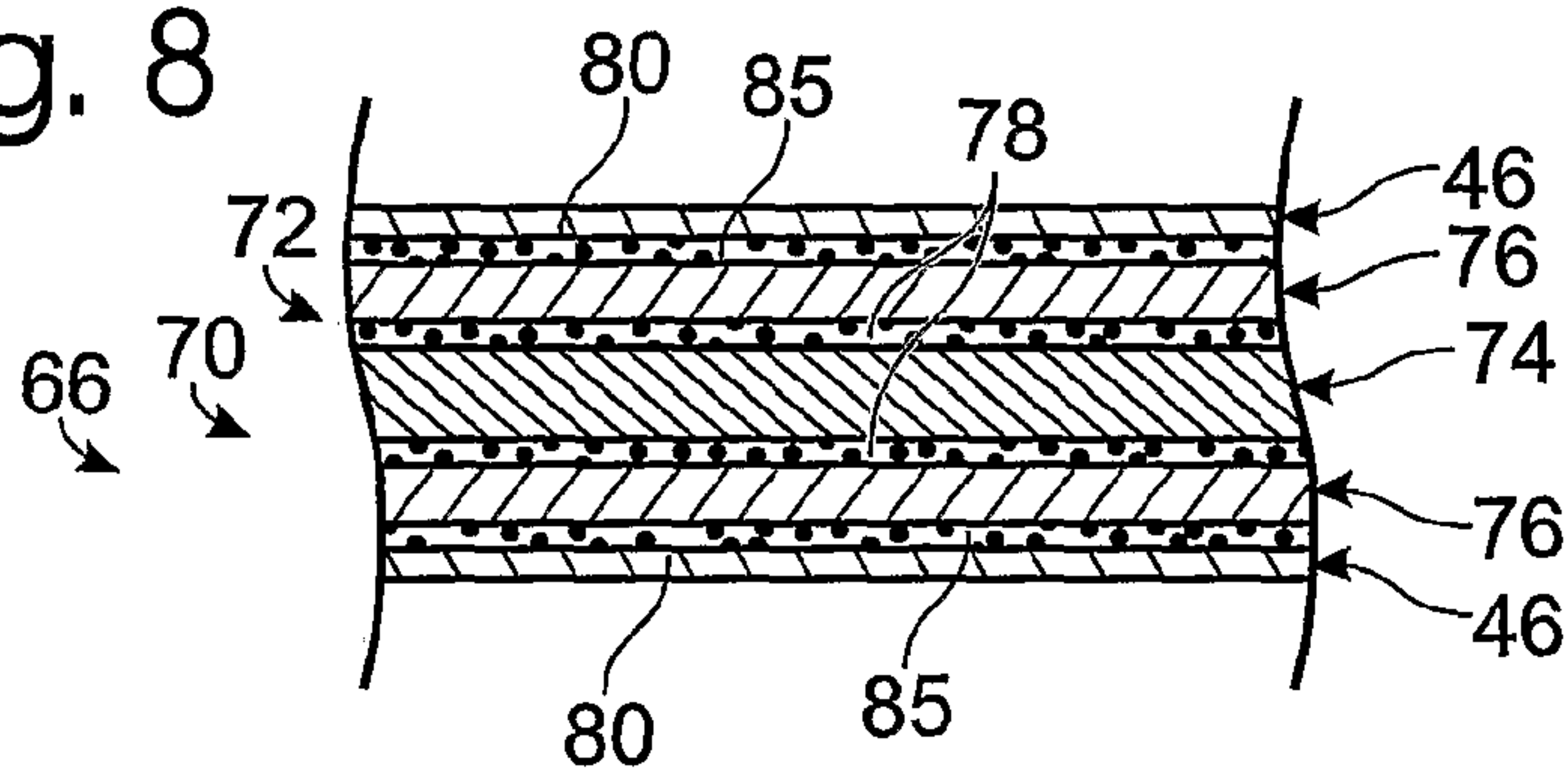
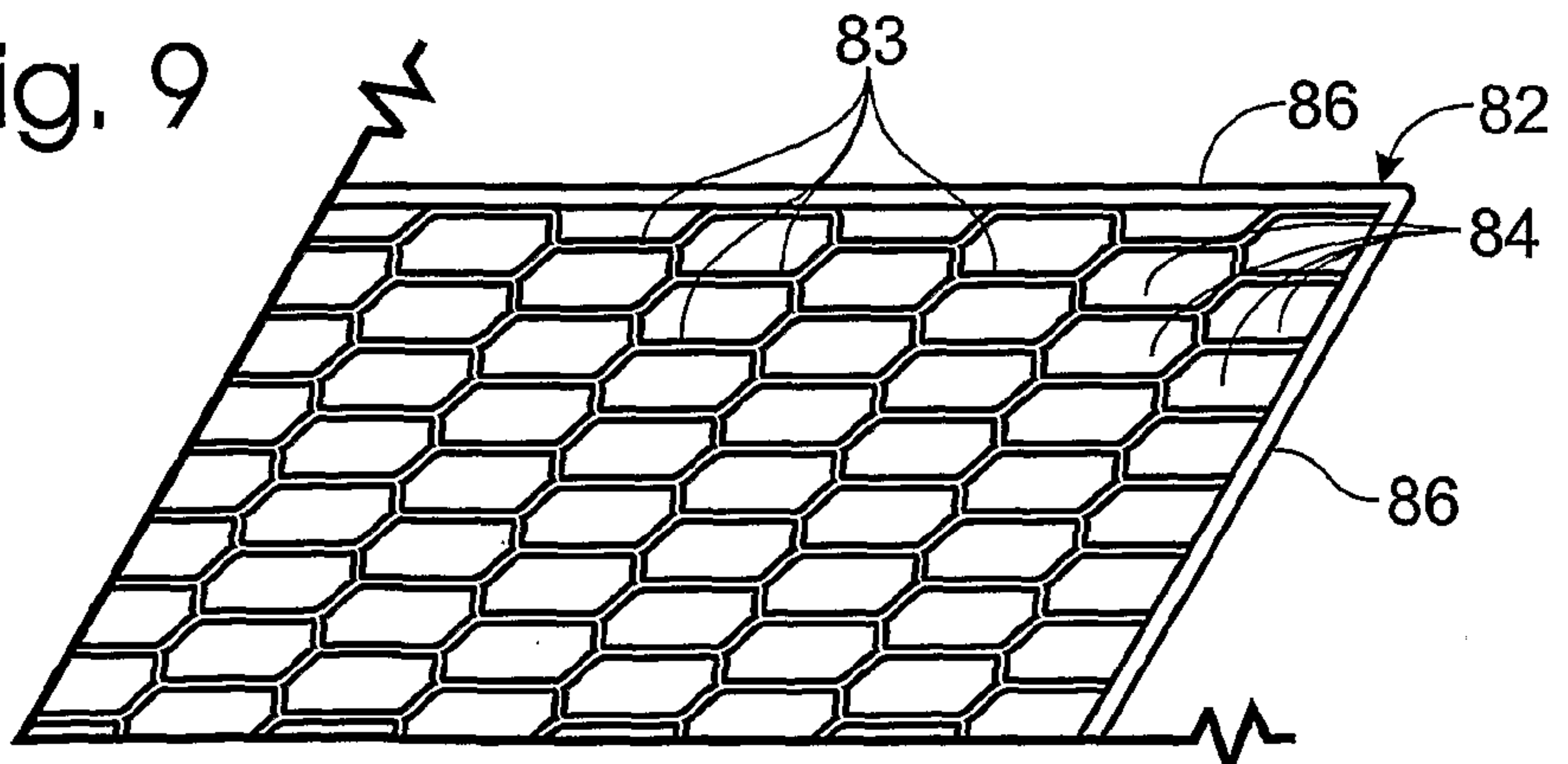

Fig. 9



4/9

Fig. 10

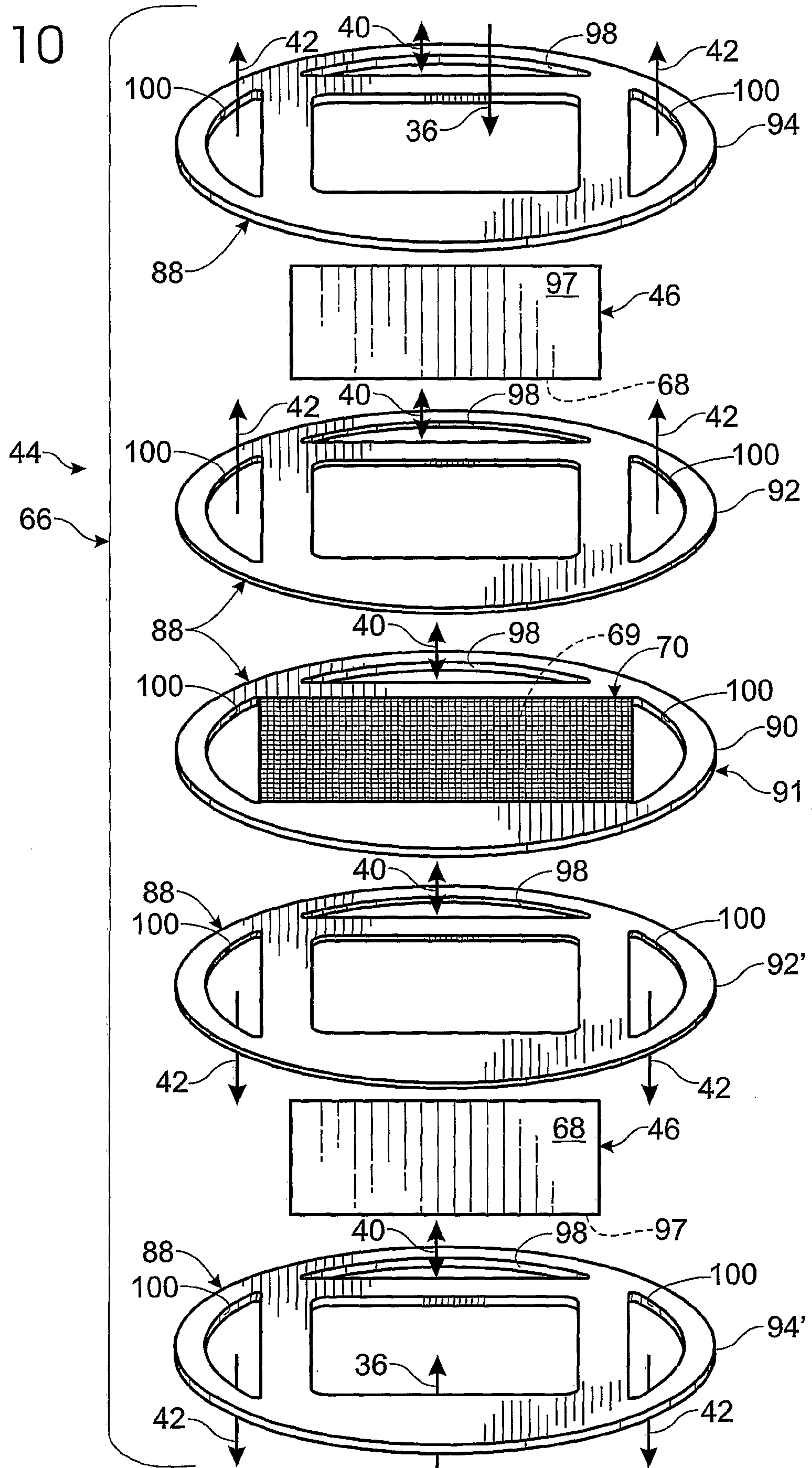

Fig. 11

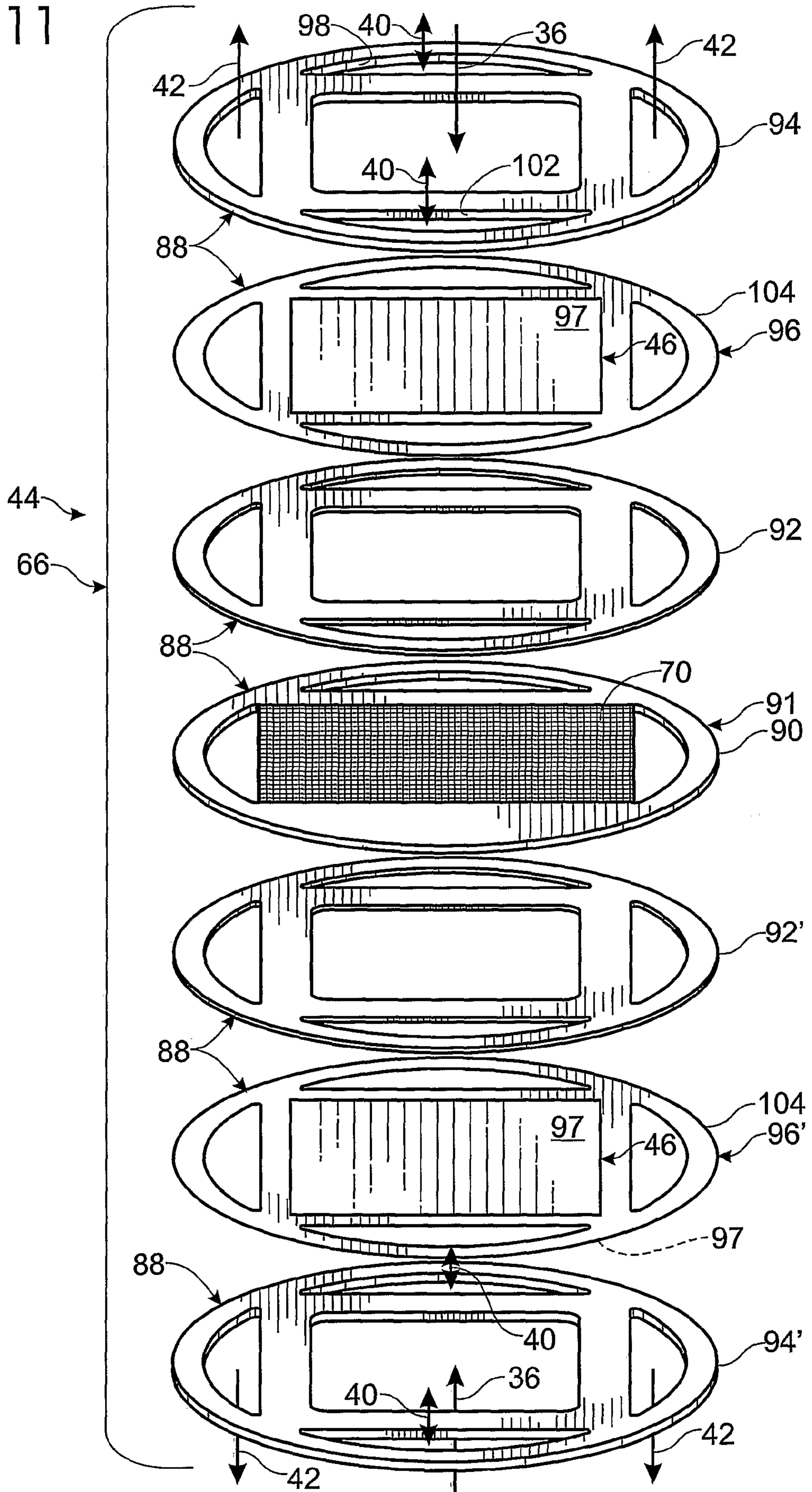
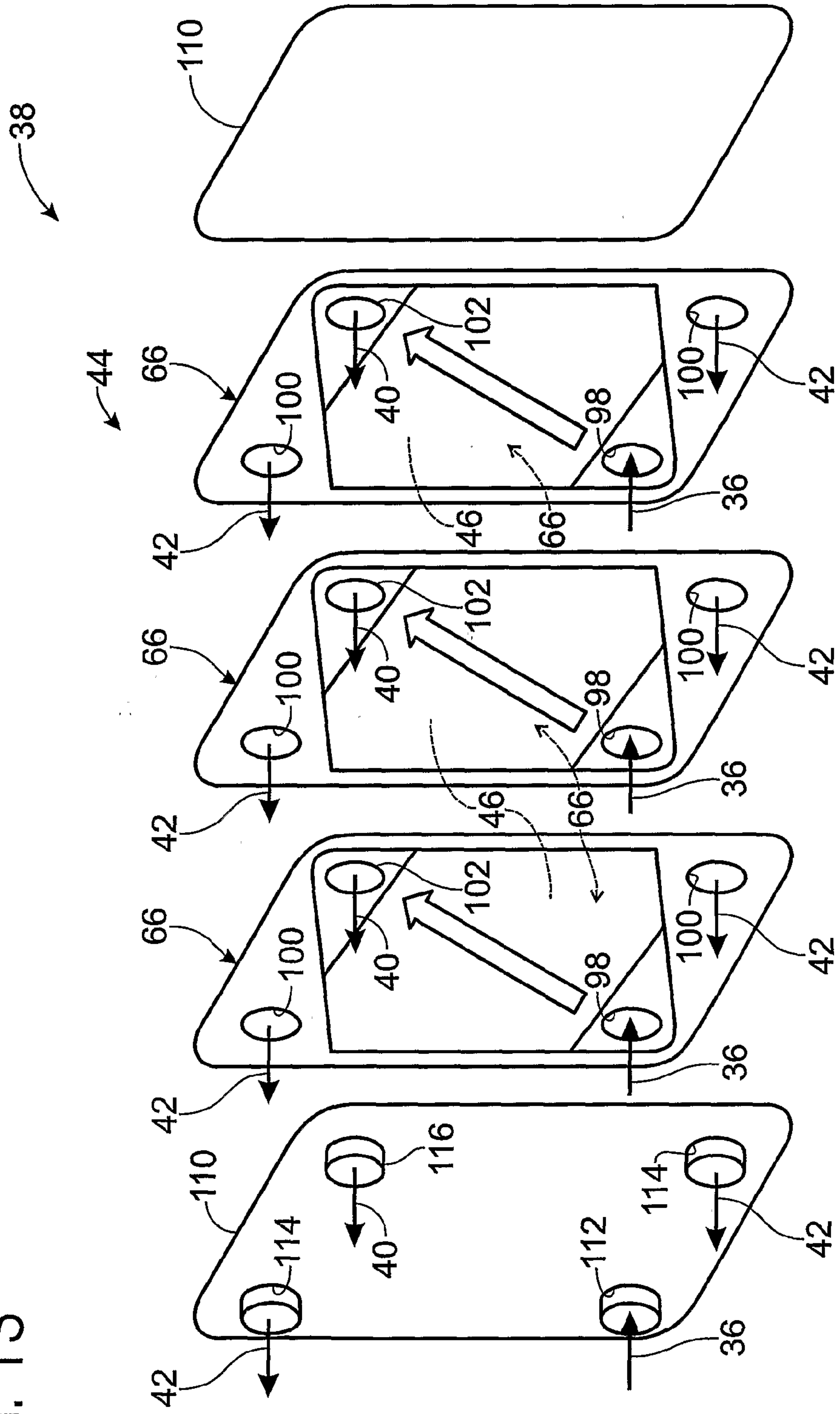

Fig. 13



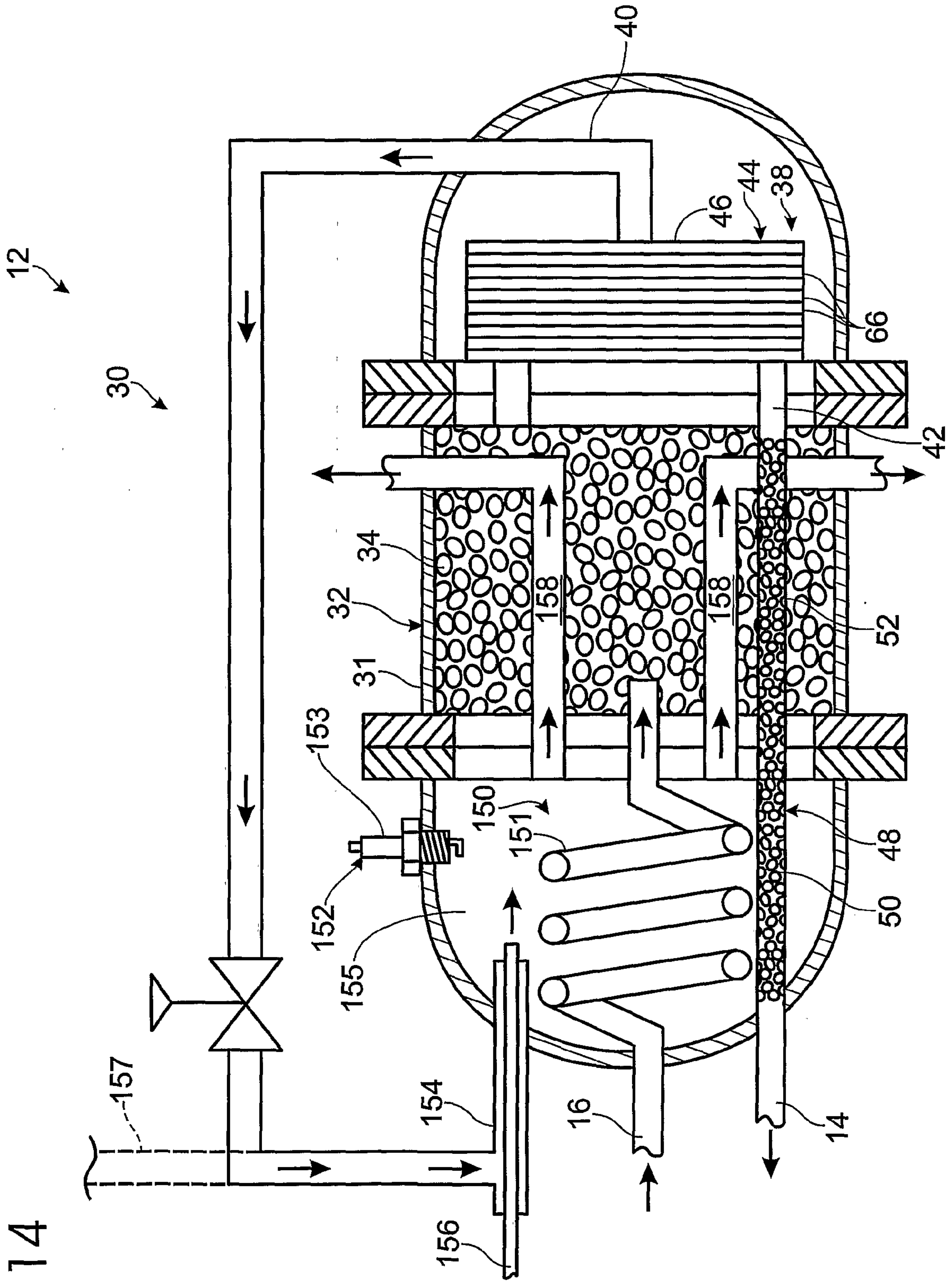

Fig. 14

Fig. 15

