



US00D924113S

(12) **United States Design Patent** (10) **Patent No.:** **US D924,113 S**
Kaoud et al. (45) **Date of Patent:** **** Jul. 6, 2021**

- (54) **VEHICLE WHEEL**
- (71) Applicant: **Ford Global Technologies, LLC**,
Dearborn, MI (US)
- (72) Inventors: **Ehab N. Kaoud**, Livonia, MI (US);
William K. Moore, West Bloomfield,
MI (US); **Junghan Kim**, Troy, MI (US)
- (73) Assignee: **Ford Global Technologies, LLC**,
Dearborn, MI (US)

D718,207	S	*	11/2014	Grake	D12/211
D748,559	S	*	2/2016	Zhao	D12/211
D769,168	S	*	10/2016	Valencia Pollex	D12/211
D775,577	S	*	1/2017	Holstein	D12/211
D824,832	S	*	8/2018	Oh	D12/209
D849,641	S	*	5/2019	Tovey	D12/209
D852,703	S	*	7/2019	De Jung	D12/209
D852,712	S	*	7/2019	Khachatryan	D12/211
D853,301	S	*	7/2019	Hahn	D12/209
D861,570	S	*	10/2019	Bjerke	D12/211
D887,937	S	*	6/2020	Platto	D12/209
D888,640	S	*	6/2020	Hough	D12/209

(**) Term: **15 Years**

(21) Appl. No.: **29/724,003**

(22) Filed: **Feb. 12, 2020**

(51) **LOC (13) Cl.** **12-16**

(52) **U.S. Cl.** **D12/209**

(58) **Field of Classification Search**

USPC D12/204–213; D21/563
 CPC B60B 7/00; B60B 7/02; B60B 7/04; B60B
 7/01; B60B 7/06; B60B 3/02; B60B 3/04;
 B60B 3/06; B60B 3/10; B60B 1/00;
 B60B 1/08; B60B 1/10; B60B 1/12
 See application file for complete search history.

(56) **References Cited**

U.S. PATENT DOCUMENTS

D569,777	S	*	5/2008	Chung	D12/211
D658,560	S	*	5/2012	Thurner	D12/209
D669,010	S	*	10/2012	Nakano	D12/211
D704,119	S	*	5/2014	Platto	D12/209
D705,153	S	*	5/2014	Hall	D12/209
D715,723	S	*	10/2014	Gotschke	D12/211

OTHER PUBLICATIONS

Andrew Wendler, The 2021 Ford F-150, Spied Testing, Looks Pretty Evolutionary, May 8, 2019 <https://www.caranddriver.com/news/a27409108/2021-ford-f-150-pickup-spied/>.

* cited by examiner

Primary Examiner — Stacia A Cadmus
(74) *Attorney, Agent, or Firm* — Michael Spenner

(57) **CLAIM**

The ornamental design for a vehicle wheel, as shown and described.

DESCRIPTION

FIG. 1 is a front elevational view of a vehicle wheel showing our new design; and, FIG. 2 is a perspective view thereof. The claimed design is indicated by the relatively dark portions in the figures. The de-emphasized and relatively light portions form no part of the claimed design.

1 Claim, 2 Drawing Sheets

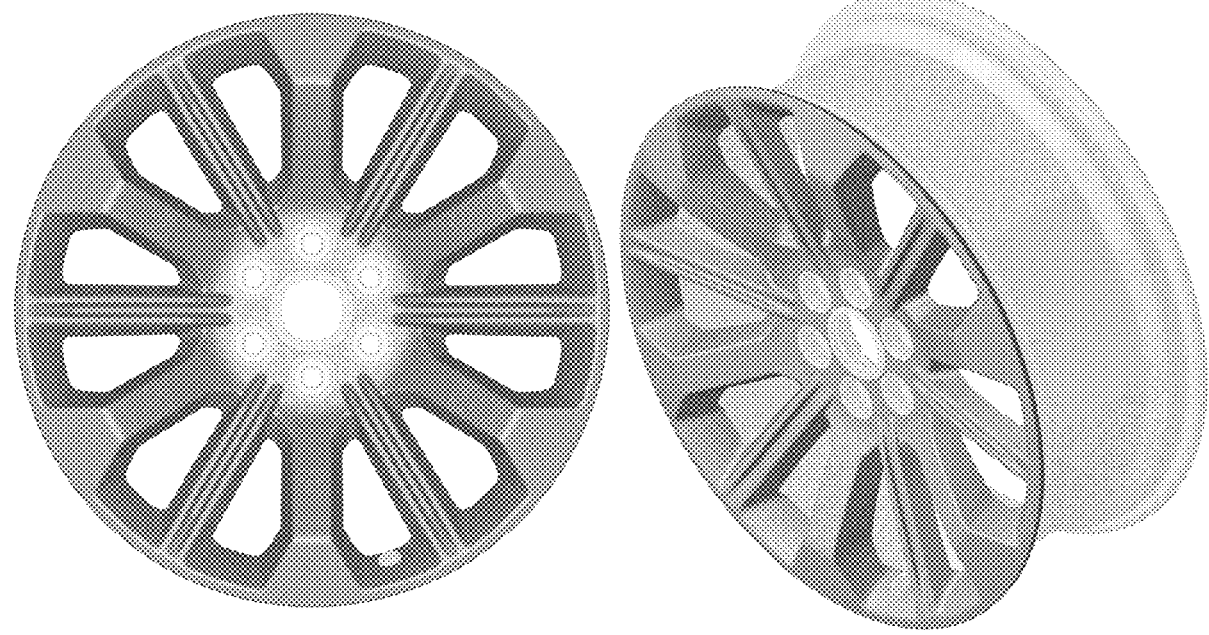

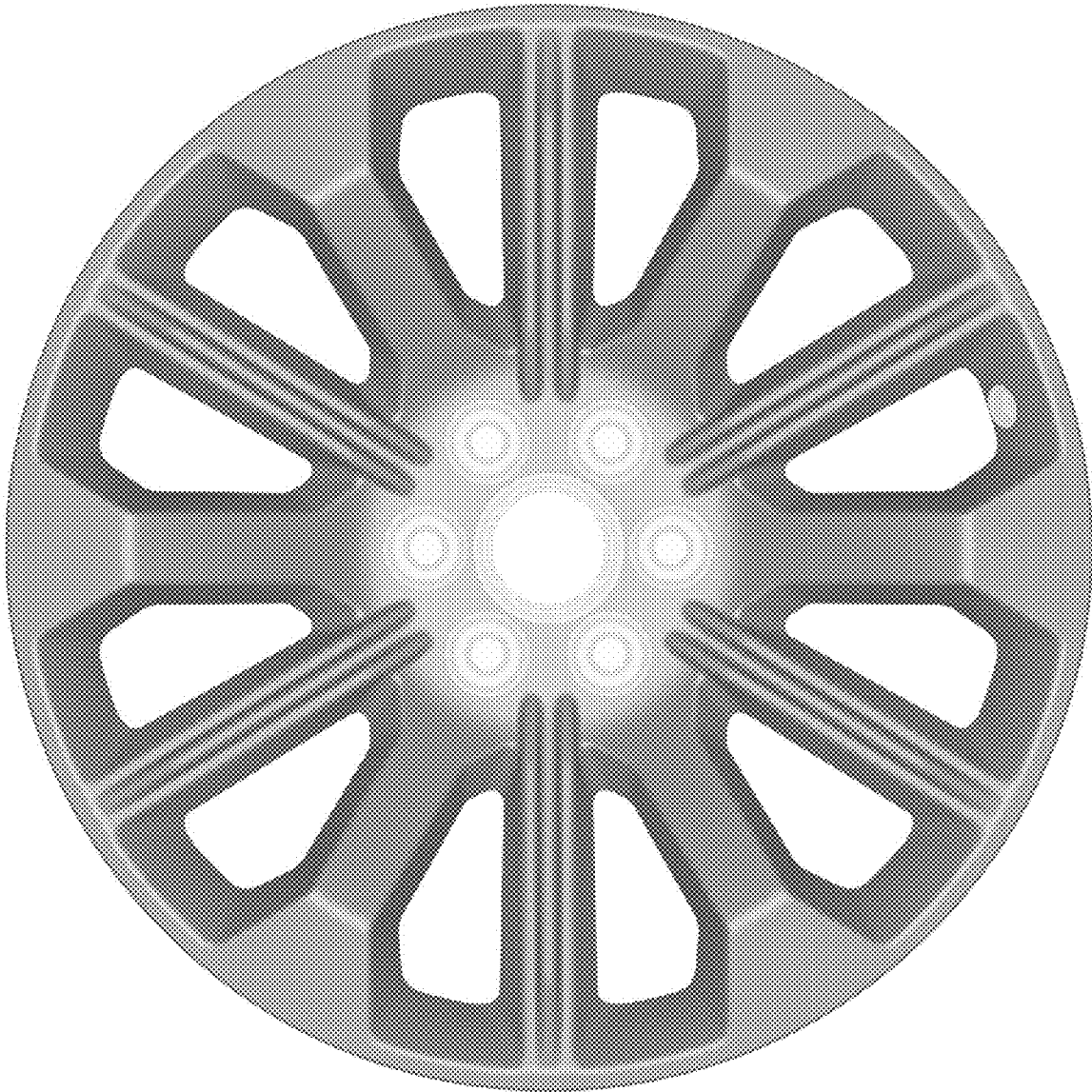

Fig.1

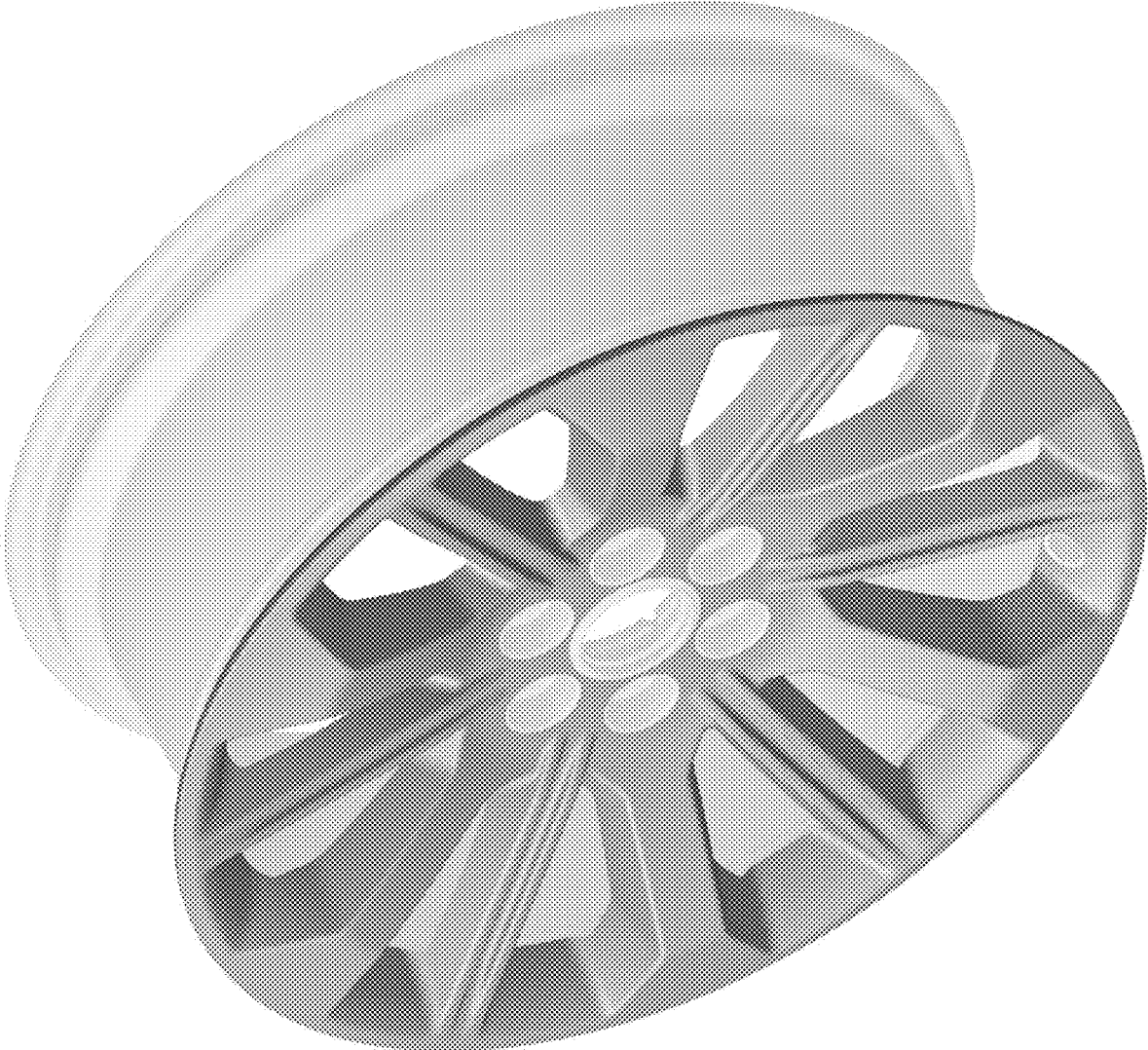

Fig. 2