



INTERNATIONAL APPLICATION PUBLISHED UNDER THE PATENT COOPERATION TREATY (PCT)

<p>(51) International Patent Classification ⁷ : B01L 3/00 // B01J 19/00, C12Q 1/68, G01N 21/17, 21/33, 21/75</p>	<p>A1</p>	<p>(11) International Publication Number: WO 00/69560</p> <p>(43) International Publication Date: 23 November 2000 (23.11.00)</p>
<p>(21) International Application Number: PCT/US00/13131</p> <p>(22) International Filing Date: 12 May 2000 (12.05.00)</p> <p>(30) Priority Data: 60/134,086 14 May 1999 (14.05.99) US</p> <p>(63) Related by Continuation (CON) or Continuation-in-Part (CIP) to Earlier Application US 60/134,086 (CON) Filed on 14 May 1999 (14.05.99)</p> <p>(71) Applicant (for all designated States except US): GAMERA BIOSCIENCE CORPORATION [US/US]; 200 Boston Avenue, Medford, MA 02155 (US).</p> <p>(72) Inventors; and (75) Inventors/Applicants (for US only): KELLOGG, Gregory [US/US]; 137 Magazine Street, Cambridge, MA 02139 (US). CARVALHO, Bruce, L. [US/US]; 59 Merrill Road, Watertown, MA 02172 (US). SHEPPARD, Norman, F., Jr. [US/US]; 6 Battle Flag Road, Bedford, MA 01730 (US). NOONAN, Kevin, E. [US/US]; 70 West Burton Place, Chicago, IL 60610 (US).</p>	<p>(74) Agent: NOONAN, Kevin, E.; McDonnell Boehnen Hulbert & Berghoff, 300 South Wacker Drive, Chicago, IL 60606 (US).</p> <p>(81) Designated States: AE, AL, AM, AT, AU, AZ, BA, BB, BG, BR, BY, CA, CH, CN, CU, CZ, DE, DK, EE, ES, FI, GB, GD, GE, GH, GM, HR, HU, ID, IL, IN, IS, JP, KE, KG, KP, KR, KZ, LC, LK, LR, LS, LT, LU, LV, MD, MG, MK, MN, MW, MX, NO, NZ, PL, PT, RO, RU, SD, SE, SG, SI, SK, SL, TJ, TM, TR, TT, UA, UG, US, UZ, VN, YU, ZA, ZW, ARIPO patent (GH, GM, KE, LS, MW, SD, SL, SZ, TZ, UG, ZW), Eurasian patent (AM, AZ, BY, KG, KZ, MD, RU, TJ, TM), European patent (AT, BE, CH, CY, DE, DK, ES, FI, FR, GB, GR, IE, IT, LU, MC, NL, PT, SE), OAPI patent (BF, BJ, CF, CG, CI, CM, GA, GN, GW, ML, MR, NE, SN, TD, TG).</p> <p>Published <i>With international search report.</i></p>	

(54) Title: A CENTRIPETALLY-MOTIVATED MICROFLUIDICS SYSTEM FOR PERFORMING IN VITRO HYBRIDIZATION AND AMPLIFICATION OF NUCLEIC ACIDS

(57) Abstract

This invention relates to methods and apparatus for performing microanalytic and microsynthetic analyses and procedures. The invention provides a microsystem platform and a micromanipulation device for manipulating the platform that utilizes the centripetal force resulting from rotation of the platform to motivate fluid movement through microchannels. The microsystem platforms of the invention are provided having arrays of thermal control regions, wherein fluid applied to the platform can be placed at a temperature and maintained at that temperature for a time that is dependent on the path length of the channel in the region, the cross-sectional dimension of the channel, and the rotational speed of the platform. Methods specific for the apparatus of the invention for performing any of a wide variety of micro-analytical or microsynthetic processes are provided.

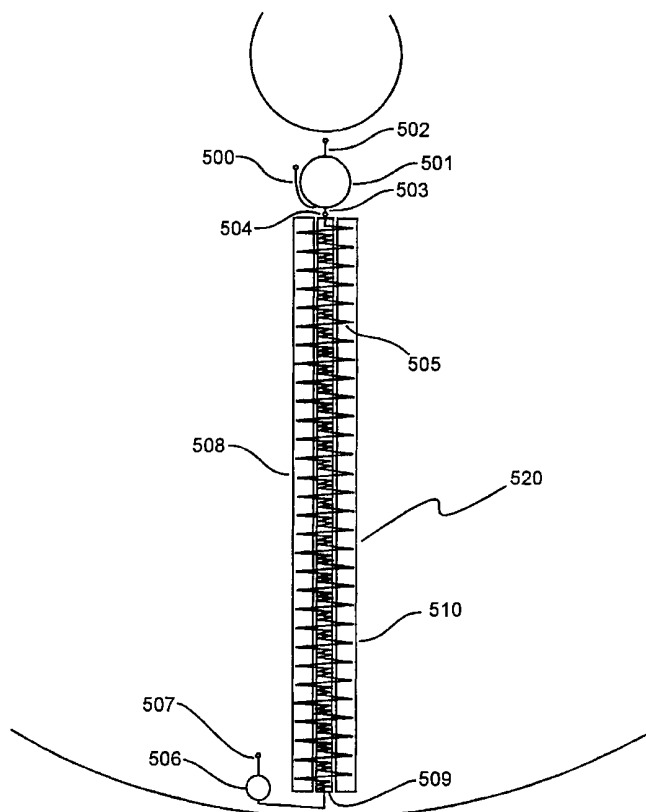

FOR THE PURPOSES OF INFORMATION ONLY

Codes used to identify States party to the PCT on the front pages of pamphlets publishing international applications under the PCT.

AL	Albania	ES	Spain	LS	Lesotho	SI	Slovenia
AM	Armenia	FI	Finland	LT	Lithuania	SK	Slovakia
AT	Austria	FR	France	LU	Luxembourg	SN	Senegal
AU	Australia	GA	Gabon	LV	Latvia	SZ	Swaziland
AZ	Azerbaijan	GB	United Kingdom	MC	Monaco	TD	Chad
BA	Bosnia and Herzegovina	GE	Georgia	MD	Republic of Moldova	TG	Togo
BB	Barbados	GH	Ghana	MG	Madagascar	TJ	Tajikistan
BE	Belgium	GN	Guinea	MK	The former Yugoslav Republic of Macedonia	TM	Turkmenistan
BF	Burkina Faso	GR	Greece	ML	Mali	TR	Turkey
BG	Bulgaria	HU	Hungary	MN	Mongolia	TT	Trinidad and Tobago
BJ	Benin	IE	Ireland	MR	Mauritania	UA	Ukraine
BR	Brazil	IL	Israel	MW	Malawi	UG	Uganda
BY	Belarus	IS	Iceland	MX	Mexico	US	United States of America
CA	Canada	IT	Italy	NE	Niger	UZ	Uzbekistan
CF	Central African Republic	JP	Japan	NL	Netherlands	VN	Viet Nam
CG	Congo	KE	Kenya	NO	Norway	YU	Yugoslavia
CH	Switzerland	KG	Kyrgyzstan	NZ	New Zealand	ZW	Zimbabwe
CI	Côte d'Ivoire	KP	Democratic People's Republic of Korea	PL	Poland		
CM	Cameroon	KR	Republic of Korea	PT	Portugal		
CN	China	KZ	Kazakstan	RO	Romania		
CU	Cuba	LC	Saint Lucia	RU	Russian Federation		
CZ	Czech Republic	LI	Liechtenstein	SD	Sudan		
DE	Germany	LK	Sri Lanka	SE	Sweden		
DK	Denmark	LR	Liberia	SG	Singapore		
EE	Estonia						

**A CENTRIPETALLY-MOTIVATED MICROFLUIDICS SYSTEM FOR
PERFORMING IN VITRO HYBRIDIZATION AND AMPLIFICATION OF
NUCLEIC ACIDS**

5

BACKGROUND OF THE INVENTION

1. Field of the Invention

This invention relates to methods and apparatus for performing microanalytic and microsynthetic analyses and procedures. In particular, the invention relates to microminiaturization of genetic, biochemical and bioanalytic processes. Specifically, the invention relates to performing bioanalytic and biotechnological processes that are dependent on incubating samples and solutions at different temperatures, and particularly reactions that require sequential sample incubation at alternating temperatures, including *in vitro* amplification reactions and most particularly the polymerase chain reaction. Methods for performing any of a wide variety of such microanalytical or microsynthetic processes using the microsystems apparatus of the invention are also provided.

2. Background of the Related Art

In the biological and biochemical arts, analytical procedures frequently require incubation of biological samples and reaction mixtures at temperatures greater than ambient temperature. Moreover, many bioanalytical and biosynthetic techniques require incubation at more than one temperature, either sequentially or over the course of a reaction scheme or protocol.

One example of such a bioanalytical reaction is the polymerase chain reaction. The polymerase chain reaction (PCR) is a technique that permits amplification and detection of nucleic acid sequences. See U.S. Patent Nos. 4,683,195 to Mullis *et al.* and 4,683,202 to Mullis. This technique has a wide variety of biological applications, including for example, DNA sequence analysis, probe generation, cloning of nucleic acid sequences, site-directed mutagenesis, detection of genetic mutations, diagnoses of viral infections, molecular “fingerprinting,” and the monitoring of contaminating microorganisms in biological fluids and other sources. The polymerase chain reaction comprises repeated rounds, or cycles, of

target denaturation, primer annealing, and polymerase-mediated extension; the reaction process yields an exponential amplification of a specific target sequence.

5 Methods for miniaturizing and automating PCR are desirable in a wide variety of analytical contexts, particularly under conditions where a large multiplicity of samples must be analyzed simultaneously or when there is a small amount of sample to be analyzed.

10 In addition to PCR, other *in vitro* amplification procedures, including ligase chain reaction as disclosed in U.S. Patent 4,988,617 to Landegren and Hood, are known and advantageously used in the prior art. More generally, several important methods known in the biotechnology arts, such as nucleic acid hybridization and sequencing, are dependent upon changing the temperature of solutions containing sample molecules in a controlled fashion. Automation and miniaturization of the performance of these methods are desirable goals in the art.

Mechanical and automated fluid handling systems and instruments produced to perform automated PCR have been disclosed in the prior art.

15 U.S. Patent 5,304,487, issued April 19, 1994 to Wilding *et al.* teach fluid handling on microscale analytical devices.

International Application, Publication No. WO93/22053, published 11 November 1993 to University of Pennsylvania disclose microfabricated detection structures.

20 International Application, Publication No. WO93/22058, published 11 November 1993 to University of Pennsylvania disclose microfabricated structures for performing polynucleotide amplification.

Wilding *et al.*, 1994, *Clin. Chem.* 40: 43-47 disclose manipulation of fluids on straight channels micromachined into silicon.

25 Kopp *et al.*, 1998, *Science* 280: 1046 discloses microchips for performing *in vitro* amplification reactions using alternating regions of different temperature.

30 One drawback of the synthetic microchips disclosed in the prior art for performing PCR and other temperature-dependent bioanalytic reactions has been the difficulty in designing systems for moving fluids on the microchips through channels and reservoirs having diameters in the 10-100 μ m range. This is due in part to the need for high-pressure pumping means for moving fluid through the small sizes of the components of these

microchips. These disabilities of the prior art microchips limits the usefulness of these devices for miniaturizing and automating PCR and other bioanalytic processes.

Some of the present inventors have developed a microsystem platform and a micromanipulation device to manipulate said platform by rotation, thereby utilizing the centripetal forces resulting from rotation of the platform to motivate fluid movement through microchannels embedded in the microplatform, as disclosed in co-owned U.S. Patent No. 6,063,589, issued May 16, 2000, and co-owned and co-pending patent applications U.S. Serial Nos. 08/761,063, filed December 5, 1996; 08/768,990, filed December 18, 1996; 08/910,726, filed August 12, 1997; 08/995,056, filed December 19, 1997; and 09/315,114, filed May 19, 1999, the disclosures of each of which are explicitly incorporated by reference herein.

SUMMARY OF THE INVENTION

This invention provides microsystems platforms as disclosed in co-owned U.S. Patent No. 6,063,589, issued May 16, 2000, and co-owned and co-pending patent applications U.S. Serial Nos. 08/761,063, filed December 5, 1996; 08/768,990, filed December 18, 1996; 08/910,726, filed August 12, 1997; 08/995,056, filed December 19, 1997; and 09/315,114, filed May 19, 1999, the disclosures of each of which are explicitly incorporated by reference herein.

The invention provides apparatus and methods for performing microscale processes on a microplatform, whereby fluid is moved on the platform in defined channels motivated by centripetal force arising from rotation of the platform. The first element of the apparatus of the invention is a microplatform that is a rotatable structure, most preferably a disk, the disk comprising fluid (sample) inlet ports, fluidic microchannels, reagent reservoirs, reaction chambers, detection chambers and sample outlet ports, generically termed "microfluidic structures," and most preferably heating elements comprising a portion of the surface area of the platform for heating fluids contained therein to temperatures greater than ambient temperature. The disk is rotated at speeds from about 1-30,000 rpm for generating centripetal acceleration that enables fluid movement through the microfluidic structures of

the platform. The disks of the invention also preferably comprise air outlet ports and air displacement channels. The air outlet ports and in particular the air displacement ports provide a means for fluids to displace air, thus ensuring uninhibited movement of fluids on the disk. Specific sites on the disk also preferably comprise elements that allow fluids to be analyzed, as well as detectors for each of these effectors. Alternatively, some or all of these elements can be contained on a second disk that is placed in optical or direct physical contact, most preferably thermal contact, with the first platform disk.

The second element of the invention is a micromanipulation device that is a disk player/ reader device that controls the function of the disk. This device comprises mechanisms and motors that enable the disk to be loaded and rotated. In addition, the device provides means for a user to operate the microsystems in the disk and access and analyze data, preferably using a keypad and computer display.

The invention specifically provides microsystems platforms comprising regions of the platform surface that comprise or are in thermal contact with heating elements, wherein fluids contained in such regions, most preferably in microchannels as defined herein, are efficiently heated to and maintained at temperatures greater than ambient for a time that is proportional to the length of the longitudinal extent or path of the microchannel in the region, the viscosity of the fluid and inversely proportional to the product of the square of the hydraulic diameter of the microchannel, the square of the rotational speed of the platform, the average distance of the fluid in the channels from the center of the disk and the radial extent of the fluid subject to the centripetal force. For fluids with defined viscosities, one combine the controlled rotational speed of the platform with engineered or designed microchannels to control the flow rate of fluids within the disk.

In certain preferred embodiments, said regions of the platform comprising or in thermal contact with a heating element or multiplicity thereof (termed herein a "thermal array") comprise an array of heating elements that can be operated at different temperatures. In these embodiments, the proportion of time that a fluid contained in said region, most preferably in a microchannel, is maintained at a particular temperature is directly proportional to the longitudinal extent of the microchannel in the region. The path of the microchannel on the surface of the platform in the region comprising or in thermal contact

with a heating element or thermal array thereof as described herein can be straight, curved, spiral, "zig-zag," or meandering, and the path can repeatedly enter and leave any particular temperature region on the disk.

5 This arrangement of heating elements into thermal arrays and transit of microchannels through such arrays provides for incubating fluid contained in such microchannels at different temperatures without having to use the heating elements to actively change the temperature of the platform. This arrangement permits the establishment of regions of the platform that are maintained at any particular temperature greater than ambient, whereby heating and incubating a fluid is dependent on the length of 10 the portion of the microchannel in that region of the platform, and hence the amount of time the fluid spends in that region as it transits the microchannel under the influence of centripetal force from rotation of the platform.

One embodiment of such a thermal array comprises a region of the platform comprising or in thermal contact with a single heating element. In these embodiments, the 15 temperature of fluids contained in such regions, most preferably in microchannels, is alternated by movement of the fluid in the microchannel between an elevated temperature from operation of the heating element and the ambient temperature of the platform by traversal through a microchannel that enters and leaves the area comprising or in thermal contact with the heating element. The proportion of the time that the fluid is maintained at 20 the elevated temperature is directly proportional to the extent of the longitudinal path of the microchannel in the region comprising or in thermal contact with the heating element. Heating elements on the platforms of the invention encompassed by this aspect can produce elevated temperatures from 37°C to about 95°C, and the absolute amount of time the fluid is kept at the elevated temperature can be varied with platform rotational speed. The relative 25 amount of time that the fluid is maintained at the elevated temperature is dependent on the geometry of the microchannel path on the platform, the average distance of the fluid in the channels from the center of the disk, the radial extent of the fluid subject to the centripetal force and the rotation rate of the platform and can be made invariant for any particular geometry in any particular embodiment of the platforms of this aspect of the invention by 30 the judicious combination of these variables.

Another embodiment of such an thermal array comprises a region of the platform comprising or in thermal contact with two heating elements, which will be understood to encompass embodiments having a single heating element in thermal contact with two discrete regions of the platform. In one aspect of these embodiments of the invention, the areas of the platform in contact with each of the two heating elements are immediately adjacent to one another. In these embodiments, the two different areas can be operated at two different temperatures greater than the ambient temperature of the platform. In these embodiments, the temperature of fluids contained in such regions, most preferably in microchannels, is alternated between each of the two elevated temperatures produced by operation of the heating elements by traversal through a microchannel that enters and leaves the each area comprising or in thermal contact with each of the heating elements. The proportion of the time that the fluid is maintained at each of the elevated temperatures is directly proportional to the extent of the longitudinal path of the microchannel in the region comprising or in thermal contact with each of the heating elements. Platforms of the invention encompassed by this aspect can be used wherein each of the areas is independently maintained at elevated temperatures from 37°C to about 95°C by the heating elements, and the amount absolute amount of time the fluid is kept at each of the elevated temperature can be varied with platform rotational speed. The relative amount of time that the fluid is maintained at each of the elevated temperature is dependent on the geometry of the microchannel path on the platform, the average distance of the fluid in the channels from the center of the disk, the radial extent of the fluid subject to the centripetal force and the rotation rate of the platform and can be made invariant for any particular geometry in any particular embodiment of the platforms of this aspect of the invention by the judicious combination of these variables.

In related embodiments, the thermal array comprises an area of the platform comprising or in thermal contact with more than two, most preferably three, heating elements, wherein the temperatures of each of these areas can be independently maintained at a different temperature greater than the ambient temperature of the platform. In preferred embodiments, each of the areas of the platform in contact with each of the heating elements are immediately adjacent to one another. In these embodiments, the three different areas can

be operated at three different temperatures greater than the ambient temperature of the platform. In these embodiments, the temperature of fluids contained in such regions, most preferably in microchannels, is alternated between each of the elevated temperatures from operation of the heating elements by traversal through a microchannel that enters and leaves each area comprising or in thermal contact with each of the heating elements. The proportion of the time that the fluid is maintained at each of the elevated temperatures is directly proportional to the extent of the longitudinal path of the microchannel in the region comprising or in thermal contact with each of the heating elements. Platforms of the invention encompassed by this aspect can be used wherein each of the areas is independently maintained at elevated temperatures from 37°C to about 95°C, and the absolute amount of time the fluid is kept at each of the elevated temperature can be varied with platform rotational speed. The relative amount of time that the fluid is maintained at each of the elevated temperature is dependent on the geometry of the microchannel path on the platform, the average distance of the fluid in the channels from the center of the disk, the radial extent of the fluid subject to the centripetal force and the rotation rate of the platform and can be made invariant for any particular geometry in any particular embodiment of the platforms of this aspect of the invention by the judicious combination of these variables.

In an alternative embodiment, the thermal array comprises two or more areas of the platform surface comprising or in thermal contact with a heating element, wherein at least one of said areas is separated from another area by an area that does not comprise and is not in thermal contact with a heating element. This intervening area of the array is maintained at the ambient temperature of the platform. In these embodiments, a microchannel is constructed in the thermal array to traverse both the areas comprising or in thermal contact with the heating elements, and the area or areas that do not comprise or are not in thermal contact with a heating element. The proportion of time that fluid contained in such microchannels is at an elevated temperature or ambient temperature is directly proportional to the extent of the longitudinal path of the microchannel in the areas that do or do not comprise or are or are not in thermal contact with each of the heating elements.

In preferred embodiments, heat originates from a single face of the platform, most preferably from a position underneath the microfluidics components. In alternative embodiments, a fluidic disk or manifold is positioned between two thermal regulation layers each comprising heating elements to provide heating on both surfaces of the microfluidic disk.

In further alternative embodiments, the microsystems platforms of the invention comprise a multiplicity of the same or different embodiments of the thermal arrays described herein. Most preferably, each of the microchannels traversing said arrays is in fluid contact with one or a multiplicity of sample input ports or fluid holding chambers comprising a biological sample or reaction mixture. In additional preferred embodiments, each microchannel is also fluidly connected with a collection chamber, most preferably wherein each microchannel is uniquely in fluid contact with a particular collection chamber.

In preferred embodiments, the thermal arrays and regions of elevated temperatures constructed in the surface of the platforms of the invention comprise a thermal heating element. In preferred embodiments, the thermal heating element is a resistive heater element.

The invention also provides methods for using the microsystems platform for performing any bioanalytical or biosynthetic reaction that requires or advantageously includes the step of incubating a biological sample or reaction mixture at one or a multiplicity of temperatures greater than ambient temperature, and more preferably wherein incubation of the biological sample or reaction mixture at one or a multiplicity of temperatures greater than ambient temperature is performed sequentially or repetitively or both. In a preferred embodiment, the bioanalytical or biosynthetic reaction is nucleic acid hybridization, polymerase chain reaction or ligase chain reaction.

Certain preferred embodiments of the apparatus of the invention are described in greater detail in the following sections of this application and in the drawings.

BRIEF DESCRIPTION OF THE DRAWINGS

Figure 1 depicts an oblique view of a microsystems platform of the invention.

Figure 2 depicts a plan view of the microsystems platform shown in oblique view in Figure 1.

Figure 3 is a cross-sectional view of the microsystems platform shown in Figures 1 and 2.

5 Figure 4 shows a plan view of a microsystems platform comprising a multiplicity of fluidic and thermal regulatory structures for performing a nucleic acid hybridization reaction.

Figure 5 shows a plan view of a microsystems platform adapted for performing an *in vitro* amplification reaction.

10 Figure 6 is a cross-sectional view of the platform shown in Figure 5.

Figure 7 shows the arrangement of twelve fluidic structures as depicted in Figure 5 around the interior diameter of a disc.

15 **DETAILED DESCRIPTION OF PREFERRED EMBODIMENTS**

This invention provides a microplatform and a micromanipulation device as disclosed in co-owned U.S. Patent No. 6,063,589, issued May 16, 2000, and co-owned and co-pending patent applications U.S. Serial Nos. 08/761,063, filed December 5, 1996; 08/768,990, filed December 18, 1996; 08/910,726, filed August 12, 1997; 08/995,056, filed
20 December 19, 1997; 09/315,114, filed May 19, 1999, the disclosures of each of which are explicitly incorporated by reference herein, adapted for performing microanalytical and microsynthetic assays of biological samples.

For the purposes of this invention, the term "sample" will be understood to encompass any fluid, solution or mixture, either isolated or detected as a constituent of a
25 more complex mixture, or synthesized from precursor species. In particular, the term "sample" will be understood to encompass any biological species of interest, and preferably nucleic acid, and most preferably a nucleic acid in a solution wherein detection or amplification of said nucleic acid is accomplished. The term "biological sample" or "biological fluid sample" will be understood to mean any biologically-derived analytical
30 sample, including but not limited to blood, plasma, serum, lymph, saliva, tears,

cerebrospinal fluid, urine, sweat, plant and vegetable extracts, semen, and ascites fluid.

For the purposes of this invention, the term “a centripetally motivated fluid micromanipulation apparatus” is intended to include analytical centrifuges and rotors, microscale centrifugal separation apparatuses, and most particularly the microsystems
5 platforms and disk handling apparatuses as described in co-owned U.S. Patent No. 6,063,589, issued May 16, 2000, and co-owned and co-pending patent applications U.S. Serial Nos. 08/761,063, filed December 5, 1996; 08/768,990, filed December 18, 1996; 08/910,726, filed August 12, 1997; 08/995,056, filed December 19, 1997; 09/315,114, filed May 19, 1999, the disclosures of each of which are explicitly incorporated by reference
10 herein.

For the purposes of this invention, the term “microsystems platform” is intended to include centripetally-motivated microfluidics arrays as described in co-owned U.S. Patent No. 6,063,589, issued May 16, 2000, and co-owned and co-pending patent applications U.S. Serial Nos. 08/761,063, filed December 5, 1996; 08/768,990, filed December 18, 1996;
15 08/910,726, filed August 12, 1997; 08/995,056, filed December 19, 1997; 09/315,114, filed May 19, 1999, the disclosures of each of which are explicitly incorporated by reference herein.

For the purposes of this invention, the terms “capillary”, “microcapillary” and “microchannel” will be understood to be interchangeable and to be constructed of either
20 wetting or non-wetting materials where appropriate.

For the purposes of this invention, the term “fluid chamber,” “fluid holding chamber” and “collection chamber” will be understood to mean a defined volume on a microsystems platform of the invention comprising a fluid.

For the purposes of this invention, the terms “entry port” and “fluid input port” will
25 be understood to mean a defined volume on a microsystems platform of the invention comprising a means for applying a fluid to the platform.

For the purposes of this invention, the terms “exit port” and “fluid outlet port” will be understood to mean a defined volume on a microsystems platform of the invention comprising a means for removing a fluid from the platform.

30 For the purposes of this invention, the term “capillary junction” will be understood

to mean a junction of two components wherein one or both of the lateral dimensions of the junction are larger than the corresponding dimensions the capillary. In wetting or wettable systems, such junctions are where capillary valving occurs, because fluid flow through the capillaries is stopped at such junctions. In non-wetting or non-wettable junctions, the exit
5 from the chamber or reservoir is where the capillary junction occurs. In general, it will be understood that capillary junctions are formed when the dimensions of the components change from a small diameter (such as a capillary) to a larger diameter (such as a chamber) in wetting systems, in contrast to non-wettable systems, where capillary junctions form when the dimensions of the components change from a larger diameter (such as a chamber)
10 to a small diameter (such as a capillary).

For the purposes of this invention, the term “capillary action” will be understood to mean fluid flow in the absence of rotational motion or centripetal force applied to a fluid on a rotor or platform of the invention.

For the purposes of this invention, the term “capillary microvalve” will be
15 understood to mean a capillary microchannel comprising a capillary junction whereby fluid flow is impeded and can be motivated by the application of pressure on a fluid, typically by centripetal force created by rotation of the rotor or platform of the invention.

For the purposes of this invention, the term “sacrificial valve” will be understood to mean a valve preferably made of a fungible material that can be removed from the fluid flow
20 path. In preferred embodiments, said sacrificial valves are wax valves and are removed from the fluid flow path by heating, using any of a variety of heating means including infrared illumination and most preferably by activation of heating elements on or embedded in the platform surface as described in co-owned U.S. Patent No. 6,063,589, incorporated by reference.

For the purposes of this invention, the term “in fluid communication” or “fluidly
25 connected” is intended to define components that are operably interconnected to allow fluid flow between components. In preferred embodiments, the platform comprises a rotatable platform, more preferably a disk, whereby fluid movement on the disk is motivated by centripetal force upon rotation of the disk.

30

For the purposes of this invention, the term “air displacement channels ” will be understood to include ports in the surface of the platform that are contiguous with the components (such as microchannels, chambers and reservoirs) on the platform, and that comprise vents and microchannels that permit displacement of air from components of the platforms and rotors by fluid movement.

The microplatforms of the invention (preferably and hereinafter collectively referred to as “disks”; for the purposes of this invention, the terms “microplatform”, “microsystems platform” and “disk” are considered to be interchangeable), are provided to comprise one or a multiplicity of microsynthetic or microanalytic systems. Such microsynthetic or microanalytic systems in turn comprise combinations of related components as described in further detail herein that are operably interconnected to allow fluid flow between components upon rotation of the disk. These components can be microfabricated as described below either integral to the disk or as modules attached to, placed upon, in contact with or embedded in the disk. For the purposes of this invention, the term “microfabricated” refers to processes that allow production of these structures on the sub-millimeter scale. These processes include but are not restricted to molding, photolithography, etching, stamping and other means that are familiar to those skilled in the art.

The invention also comprises a micromanipulation device for manipulating the disks of the invention, wherein the disk is rotated within the device to provide centripetal force to effect fluid flow on the disk. Accordingly, the device provides means for rotating the disk at a controlled rotational velocity, for stopping and starting disk rotation, and advantageously for changing the direction of rotation of the disk. Both electromechanical means and control means, as further described herein, are provided as components of the devices of the invention. User interface means (such as a keypad and a display) are also provided, as further described in co-owned U.S. Patent No. 6,063,589, issued May 16, 2000, and co-owned and co-pending patent applications U.S. Serial Nos. 08/761,063, filed December 5, 1996; 08/768,990, filed December 18, 1996; 08/910,726, filed August 12, 1997; 08/995,056, filed December 19, 1997; 09/315,114, filed May 19, 1999, the disclosures of each of which are explicitly incorporated by reference herein.

The invention provides a combination of specifically-adapted microplatforms that

are rotatable, analytic/synthetic microvolume assay platforms (collectively referred to herein as a “disk” or “disc”), and a micromanipulation device for manipulating the platform to achieve fluid movement on the platform arising from centripetal force on the platform as result of rotation. The platform of the invention is preferably and advantageously a circular disk; however, any platform capable of being rotated to impart centripetal for a fluid on the platform is intended to fall within the scope of the invention. Preferably, the disk incorporates microfabricated mechanical, optical, and fluidic control components on platforms made from, *for example*, plastic, silica, quartz, metal or ceramic.

These structures are constructed on a sub-millimeter scale by molding, photolithography, etching, stamping or other appropriate means.

Platforms of the invention such as disks and the components comprising such platforms are advantageously provided having a variety of composition and surface coatings appropriate for a particular application. Platform composition will be a function of structural requirements, manufacturing processes, and reagent compatibility/chemical resistance properties. Specifically, platforms are provided that are made from inorganic crystalline or amorphous materials, *e.g.* silicon, silica, quartz, inert metals, or from organic materials such as plastics, for example, poly(methyl methacrylate) (PMMA), acetonitrile-butadiene-styrene (ABS), polycarbonate, polyethylene, polystyrene, polyolefins, polypropylene and metallocene. These may be used with unmodified or modified surfaces as described below.

Also provided by the invention are platforms made of composites or combinations of these materials, *for example*, platforms manufactures of a plastic material having embedded therein an optically transparent glass surface comprising for example the detection chamber of the platform. The surface properties of these materials may be modified for specific applications, as disclosed in co-owned U.S. Patent No. 6,063,589, issued May 16, 2000, and co-owned and co-pending patent applications U.S. Serial Nos. 08/761,063, filed December 5, 1996; 08/768,990, filed December 18, 1996; 08/910,726, filed August 12, 1997; 08/995,056, filed December 19, 1997; 09/315,114, filed May 19, 1999, the disclosures of each of which are explicitly incorporated by reference herein.

The platforms of the invention can be used to perform any microanalytical and microsynthetic reaction requiring that the sample be incubated at one or a multiplicity of

temperatures greater than the ambient temperature of the disk for a controlled amount of time. Most preferably, the microsystems platforms of the invention are adapted for performing nucleic acid hybridization assays and *in vitro* amplification reactions, such as the polymerase chain reaction or ligase chain reaction, using centrifugal action to move a fluid reaction mixture between various temperature controlled regions on a microfluidics disc.

For performing the polymerase chain reaction in conventional thermal cyclers, the reaction mixture remains at one location and the temperature of this location is typically cycled between a denaturation temperature ($> 90^{\circ}\text{C}$), an annealing temperature (which varies with the sequence complexity, length and hybridization fidelity of the oligonucleotide primers) and an extension temperature (usually around 70°C for reactions performed with *Taq* polymerase). Typical thermal cyclers are able to heat and cool at rates between $1^{\circ}\text{C}/\text{sec}$ and $2^{\circ}\text{C}/\text{sec}$, with a temperature accuracy and precision of approximately $\pm 1^{\circ}\text{C}$.

In contrast, the microsystem platforms of the invention do not require active temperature changes of any particular region of the platform such as a reaction chamber. Rather, thermal arrays comprising adjacent regions of different temperature are provided by the platforms of the invention, so that temperature changes are effected by transit of a fluid through a microchannel from one temperature region to another region at a different temperature. The amount of time a fluid is maintained at a particular temperature is determined by the transit time of the fluid through any particular region of a thermal array at a particular temperature, which is proportional to the longitudinal extent or length of the microchannel in that temperature region.

The present invention provides components of the microsystems platform that can perform at levels sufficiently equivalent to these specifications as to enable microminiaturization of *in vitro* amplification reactions on such platforms.

Fluid (including reagents, samples and other liquid components) movement is controlled by centripetal acceleration due to rotation of the platform. The magnitude of centripetal acceleration required for fluid to flow at a rate and under a pressure appropriate for a particular microsystem is determined by factors including but not limited to the effective radius of the platform, the interior diameter of microchannels, the position angle

of the microchannels on the platform with respect to the direction of rotation, and the speed of rotation of the platform. In certain embodiments of the methods of the invention a metered amount of the fluid sample applied to the platform is transferred from a fluid holding chamber to a microchannel as described in co-owned U.S. Patent No. 6,063,589, issued May 16, 2000, and co-owned and co-pending patent applications U.S. Serial Nos. 08/761,063, filed December 5, 1996; 08/768,990, filed December 18, 1996; 08/910,726, filed August 12, 1997; 08/995,056, filed December 19, 1997; 09/315,114, filed May 19, 1999, the disclosures of each of which are explicitly incorporated by reference herein. In preferred embodiments, the metered amount of the fluid sample provided on an inventive platform is from about 10 μ L to about 500 μ L.

The components of the platforms of the invention are in fluidic contact with one another. In preferred embodiments, fluidic contact is provided by microchannels comprising the surface of the platforms of the invention. Microchannel sizes are optimally determined by specific applications and by the amount of delivery rates required for each particular embodiment of the platforms and methods of the invention. Microchannel sizes can range from 0.1 μ m to a value close to the thickness of the disk (*e.g.*, 1mm). In preferred embodiments, the interior dimension of the microchannel is from 1 to about 200 μ m, more preferably about 50 μ m for microchannels having a circular aspect and 50 μ m x 50 μ m for microchannels having a square aspect. Microchannel and reservoir shapes can be trapezoid, circular or other geometric shapes as required. Microchannels preferably are embedded in a microsystem platform having a thickness of about 0.1 to 100mm, wherein the cross-sectional dimension of the the microchannels across the thickness dimension of the platform is less than 500 μ m and can be from 1 to 90 percent of said cross-sectional dimension of the platform. Reagent reservoirs, reaction chambers, detections chambers and sample inlet and outlet ports preferably are embedded in a microsystem platform having a thickness of about 0.1 to 100mm, wherein the cross-sectional dimension of the the microchannels across the thickness dimension of the platform is from 1 to 75 percent of said cross-sectional dimension of the platform. In preferred embodiments, delivery of fluids through such channels is achieved by the coincident rotation of the platform for a time and at a rotational velocity sufficient to motivate fluid movement between the desired

components.

The flow rate through a channel is inversely proportional to the length of the longitudinal extent or path of the microchannel in the region and the viscosity of the fluid and proportional to the product of the square of the hydraulic diameter of the microchannel, the square of the rotational speed of the platform, the average distance of the fluid in the channels from the center of the disk and the radial extent of the fluid subject to the centripetal force. Since the hydraulic diameter of a channel is proportional to the ratio of the cross-sectional area to cross-sectional perimeter of a channel, one can judiciously vary the depth and width of a channel to affect the flow.

Input and output (entry and exit) ports are components of the microplatforms of the invention that are used for the introduction of removal of a variety of fluid components. Entry ports are provided to allow samples and reagents to be placed on or injected onto the disk; these types of ports are generally located towards the center of the disk. Exit ports are also provided to allow products to be removed from the disk. Port shape and design vary according specific applications. For example, sample input ports are designed, *inter alia*, to allow capillary action to efficiently draw the sample into the disk. In addition, ports can be configured to enable automated sample/reagent loading or product removal. Entry and exit ports are most advantageously provided in arrays, whereby multiple samples are applied to the disk or to effect product removal from the microplatform.

Also included in air handling systems on the disk are air displacement channels, whereby the movement of fluids displaces air through channels that connect to the fluid-containing microchannels retrograde to the direction of movement of the fluid, thereby providing a positive pressure to further motivate movement of the fluid.

Temperature control elements are provided to control the temperature of the platform during incubation of a fluid thereupon. The invention therefor provides heating elements, including heat lamps, direct laser heaters, Peltier heat pumps, resistive heaters, ultrasonication heaters and microwave excitation heaters, and cooling elements, including Peltier devices and heat sinks, radiative heat fins and other components to facilitate radiative heat loss. Thermal devices are preferably arrayed to control the temperature of the platform over a specific area or multiplicity of areas. Preferably, heating and cooling elements

comprise the platforms of the invention comprising a thermal regulation layer in the platform surface that is in thermal contact with the microfluidics components, most preferably microchannels as described herein. The temperature of any particular area on the platform (preferably, the microchannels at any particular thermally regulated area) is
5 monitored by resistive temperature devices (RTD), thermistors, liquid crystal birefringence sensors or by infrared interrogation using IR-specific detectors, and can be regulated by feedback control systems. Temperature control on the microsystems platforms of this invention is most preferably achieved using the methods and devices disclosed in co-owned U.S. Patent No. 6,063,589, incorporated by reference herein.

10 In preferred embodiments, portions of the microsystems platform surface are adapted for providing regions of controlled temperature (termed "thermal regions" or "thermal arrays" herein) using integral heating elements as disclosed in U.S. Patent 6,063,589, incorporated by reference. In more preferred embodiments, the portions of the microsystems platform surface are constituted in arrays of thermal control elements, most
15 preferably wherein is produced adjacent regions of the platform surface having different temperatures. In preferred embodiments, the platform also comprises other components as disclosed in co-owned and co-pending patent applications U.S. Serial Nos. 08/761,063, filed December 5, 1996; 08/768,990, filed December 18, 1996; 08/910,726, filed August 12, 1997; 08/995,056, filed December 19, 1997; 09/315,114, filed May 19, 1999, the
20 disclosures of each of which are explicitly incorporated by reference herein, most preferably channels and microchannels, whereby fluid flow traverses each of the different regions having different temperatures at least once, or more preferably, several times. In these embodiments, the amount of time fluid is within any particular thermal region, and thus at any particular temperature is dependent on the path length of the channel in the region, the
25 square of the hydraulic diameter of the channel, and the square of the rotational speed of the platform. In preferred embodiments, the arrays comprise at least 2 or 3 regions of different temperature adjacent to one another. In certain embodiments, the thermal regions are rectangular in shape, while in other embodiments the thermal regions are wedge-shaped, having a broader annular diameter at positions distal to the axis of rotation than at positions
30 proximal to the axis of rotation.

In preferred embodiments of the platforms of the invention, the thermal arrays and regions of elevated temperatures constructed in the surface of the platforms of the invention comprise a thermal heating element. In preferred embodiments, the thermal heating element is a resistive heater element or a thermofoil heater, which is an etched-foil heating element enclosed in an electrically insulating plastic (Kapton, obtained from Minco). Resistive heater elements comprising the platforms of the invention are as described in co-owned U.S. Patent 6,063,587. Briefly, said resistive heater elements comprise in combination an electrically inert substrate capable of being screen printed with a conductive ink and a resistive ink; a conductive ink screen-printed in a pattern; and a resistive ink screen-printed in a pattern over the conductive ink pattern wherein the resistive ink is electrical contact with the conductive ink and wherein an electrical potential applied across the conductive ink causes current to flow across the resistive ink wherein the resistive ink produces heat. Such structures are defined as "electrically-resistive patches" herein. Preferably, the conductive ink is a silver conductive ink such as Dupont 5028, Dupont 5025, Acheson 423SS, Acheson 426SS and Acheson SS24890, and the resistive ink is, for example, Dupont 7082, Dupont 7102, Dupont 7271, Dupont 7278 or Dupont 7285, or a PTC (positive temperature coefficient) ink. In alternative embodiments, the resistive heater element can further comprise a dielectric ink screen-printed over the resistive ink pattern and conductive ink pattern.

When the ratio between heater surface area and fluid volume is large, the time to heat the fluid to a desired temperature can be fast. The time for fluid to reach an equilibrium temperature can be approximated by the square of the channel depth divided by the thermal diffusivity of the fluid. For water, the thermal diffusivity is about $1.44 \times 10^{-4} \text{ cm}^2/\text{sec}$ and for a channel $50 \mu\text{m}$ deep (*i.e.*, $5 \times 10^{-3} \text{ cm}$), the time required to reach thermal equilibrium is calculated to be about 0.2 sec. For amplification reactions like PCR, it is desirable to ensure that it takes a hypothetical liquid front much longer than the thermal equilibrium time to traverse a particular temperature region on the disc surface. For example, using a platform of the invention having microchannels with an interior dimension of 50 μm , an overall channel length of 20 cm and a rotational speed of 590 rpm, when the mean distance of the fluid from the center of the disk is 3 cm and the radial extent of the fluid subject to

centripetal force is 5cm, the flow rate is about 6nL/sec. Thus, for fluid volumes greater than 6nL, the traversal time for any given temperature region on the disc is greater than 1 second. Since 1sec > 0.2 sec, there is sufficient time for the fluid to reach thermal equilibrium for each temperature region traversed for typical fluid volumes used on the disc.

5 Referring now to the Figures for a more thorough description of the invention, Figure 1 shows an oblique view, Figure 2 shows a plan view and Figure 3 shows a cross-sectional view of a platform of the invention. Fluidic manifold layer **100** comprises the microfluidic components of the platform including a fluid input port and input chamber **101**, microchannel **102** and fluid collection chamber **103**. Thermal regulation layer **113** comprises the heater elements of the platform, including a pair of electrically conductive leads **107** and **108** connected to electrically resistive patch **106**. Fiducial marks **104**, **105**, **109** and **110** are use to align the manifold layer **100** and thermal regulation layer **113**. When fiducial mark **104** is aligned with **109** and fiducial mark **105** is aligned with **110**, the two layers are pressed together resulting in the plan view shown in Figure 2. When so assembled, the layers rotate together about a spindle inserted in the inner hole **111**.

15 In the plan view of this platform shown in Figure 2 is depicted the assembled platform. Fluid input port **200** is fluidly connected to fluid holding chamber **201** having a volumetric capacity of from about 1 to about 200 μ L. The fluid input port has a sufficient diameter to accommodate a standard 200 μ L plastic pipette tip. The fluid holding chamber **201** has a diameter of from about 0.3 to about 1cm and a depth in the platform surface of from about 0.02 to about 1cm. Air displacement channel **202** having a cross-sectional dimension of from about 100 to about 500 μ m is connected to fluid holding chamber **201** to permit displacement of air in fluid holding chamber **201** upon loading of a fluid sample into fluid input port **200**. The fluid holding chamber is fluidly connected through microchannel **203** having a cross-sectional dimension of from about 1 to about 200 μ m to microchannel **205**. Microchannel **205** has a cross-sectional dimension of from about 1 to about 200 μ m. A capillary microvalve **204** or, optionally, a sacrificial valve **204**, interrupts microchannel **203** and prevents fluid flow from fluid holding chamber **201** into microchannel **205** in the absence of platform rotation (*i.e.*, at zero centripetal force). Microchannel **205** is fluidly connected to collection chamber **206** having volumetric capacity of from about 1 to about

200 μ L. Collection chamber **206** has a diameter of from about 0.3 to about 1 cm and a depth in the platform surface of from about 0.02 to about 1cm. Air displacement channel **207** having a cross-sectional dimension of from about 100 to about 500 μ m is connected to collection chamber **206** to permit displacement of air in collection chamber **206** upon rotation of the platform and fluid flow from fluid holding chamber **201** through microchannel **205** and into collection chamber **206**.

Thermal control of the fluid flowing through microchannel **205** is accomplished by heating the fluid and microchannel using electrically-resistive patch **208**. Electrically conductive leads **209** and **210** control heating by electrically-resistive patch **208**. The time during which the fluid in microchannel **205** is maintained at a temperature greater than ambient is dependent on the rotational speed of the platform and the length and interior dimension of microchannel **205**.

The cross-sectional view of the platform is shown in Figure 3. Electrically-resistive patch **305** is on the surface of thermal regulation layer substrate **306**, and fluidic manifold layer **302** containing microfluidic structures including microchannel **303** in substrate layer **304** are pressed together in place using fiducial registers as shown in Figures 1 and 2. An insulation space **301** having a volumetric capacity of from about 0.1 to about 1 cm³ is advantageously positioned in manifold layer **302** above the position of electrically-resistive patch **305** in thermal regulation layer **306**. This insulation space is optionally enclosed by cover **300**. Insulation space **301** can be empty (*i.e.*, containing only air) or can contain air trapped in fibrous material. Insulation space **301** supports the formation of a temperature gradient between the heater and the environment and permits the formation of a uniform temperature through the thickness of the capillary microchannel.

The platform shown in Figures 1-3 is useful for binding assays at a controlled temperature greater than the ambient temperature of the platform. For example, hybridization probes deposited on the walls of the microchannel, or comprising carrier beads that are motivated into the capillary channel can be used to separate hybridizing from non-hybridizing material in a biological sample, particularly if the carrier beads are retained in the microchannel.

Figure 4 shows a microsystems platform according to the invention adapted for performing hybridization arrays. In the Figure, fluid input port **400** is fluidly connected to fluid holding chamber **401** having a volumetric capacity of from about 10 to about 200 μ L. The fluid input port has a sufficient diameter to accommodate a standard 200 μ L plastic pipette tip. Fluid holding chamber **401** has a diameter of from about 1 to about 3 cm and a depth in the platform surface of from about 0.02 to about 1cm. Air displacement channel **402** having a cross-sectional dimension of from about 100 to about 500 μ m is connected to fluid holding chamber **401** to permit displacement of air in fluid holding chamber **401** upon loading of a fluid sample into fluid input port **400**. The fluid holding chamber is fluidly connected through a multiplicity of microchannels **403** having a cross-sectional dimension of from about 1 to about 200 μ m to an equivalent multiplicity of microchannels **405**. Microchannels **405** each have a cross-sectional dimension of from about 1 to about 200 μ m. Capillary microvalves **404** or, optionally, sacrificial valves **404**, interrupt microchannels **403** and prevent fluid flow from fluid holding chamber **401** into microchannels **405** in the absence of platform rotation (*i.e.*, at zero centripetal force). Microchannels **405** are fluidly connected to hybridization chambers **406** having volumetric capacity of from about 1 to about 20 μ L. The hybridization chambers have a diameter of from about 0.1 to about 1 cm and a depth in the platform surface of from about 10 to about 200 μ m. Positioned in thermal contact with each of hybridization chambers **406** are heating elements **407**, most preferably electrically-resistive patches contained in a thermal regulation layer as shown in Figures 1-3. Hybridization chambers **406** are optionally and advantageously fluidly connected to detection chambers **410**. Detection chambers **410** enable detection of hybridization reaction products, most preferably using optical detectors and detection methods, as described more completely in 6,063,589, issued May 16, 2000, and co-owned and co-pending patent applications U.S. Serial Nos. 08/761,063, filed December 5, 1996; 08/768,990, filed December 18, 1996; 08/910,726, filed August 12, 1997; 08/995,056, filed December 19, 1997; and 09/315,114, filed May 19, 1999, the disclosures of each of which are explicitly incorporated by reference herein.

Detection chambers **410** are fluidly connected through capillaries **411** having an interior dimension of from about 1 to about 200 μ m to common waste chamber **412**, that has

a diameter of from about 1 to about 3cm and a depth in the platform surface of from about 0.02 to about 0.2cm. Air displacement channel **413** having a cross-sectional dimension of from about 100 to about 500 μ m is connected to common waste chamber **412** to permit displacement of air in common waste chamber **412** upon rotation of the platform. Uses of this type of platform are exemplified herein in Example 1.

Figures 5 and 6 depict plan and cross-sectional views of a microfluidics platform of the invention adapted for performing polymerase chain reaction or ligase chain reaction. In Figure 5, a fluid input port **500** is fluidly connected to fluid holding chamber **501** having a volumetric capacity of from about 10 to about 200 μ L. The fluid input port has a sufficient diameter to accommodate a standard 200 μ L plastic pipette tip. Fluid holding chamber **501** has a diameter of from about 1 to about 3cm and a depth in the platform surface of from about 0.02 to about 0.3cm. Air displacement channel **502** having a cross-sectional dimension of from about 100 to about 500 μ m is connected to fluid holding chamber **501** to permit displacement of air in fluid holding chamber **501** upon loading of a fluid sample into fluid input port **500**. The fluid holding chamber is fluidly connected through microchannel **503** having a cross-sectional dimension of from about 1 to about 200 μ m to thermal array **520**. A capillary microvalve **504** or, optionally, a sacrificial valve **504**, interrupts microchannel **503** and prevents fluid flow from fluid holding chamber **501** into thermal array **520** in the absence of platform rotation (at zero centripetal force).

Thermal array **520** comprises a fluid microchannel **505** that traverses the array across three thermal zones comprising individually-addressable heating elements **508**, **509** and **510**, preferably comprising a thermal regulation layer as described above and in Figure 6. Fluid microchannel **505** has a cross-sectional dimension of from about 1 to about 200 μ m. The path of microchannel **505** is shown in the Figure to represent different transit times across the different thermal zones. As shown in the Figure, the transit time in the middle thermal zone is longer than in either of the flanking thermal zones, because the microchannel path traverses this zone several times for each time the path traverses either of the flanking zones. Microchannel paths traversing the thermal zones having equal transit times or any combination of differential transit times for each zone are within the scope of this invention. Heating elements **508**, **509** and **510** are constructed to be operated at separate and distinct

temperatures greater than ambient; such heating elements are described more fully in co-owned U.S. Patent 6,063,589 issued May 16, 2000 and in co-owned and co-pending patent applications U.S. Serial Nos. 08/761,063, filed December 5, 1996; 08/768,990, filed December 18, 1996; 08/910,726, filed August 12, 1997; 08/995,056, filed December 19, 1997; 09/315,114, filed May 19, 1999, incorporated by reference. The width and length of the heating elements comprising thermal zones depicted in Figure 5 will depend on the incubation time desired for the fluid to be at each of the different temperatures in the different thermal zones. Typically, the length of the microchannel is chosen to be equivalent to 20-35 cycles of conventional PCR, wherein each cycle consists of a time interval at a denaturing temperature (from about 80°C to about 95°C), a time interval at an oligonucleotide primer annealing temperature (from about 40°C to about 65°C) and a time interval at a polymerase extension temperature (from about 60°C to about 75°C).

In alternative embodiments, the middle thermal zone is provided without a heating element, so that transit through this zone is at ambient temperature. It will be recognized that other configurations of the thermal arrays of the invention, as described herein, are also useful in constructing alternative platforms of the invention based on the platform explicitly disclosed in Figure 5.

It will also be recognized that platforms comprising a multiplicity of the microfluidic and thermal structures shown in Figure 5 are also encompassed by the invention, wherein individual fluid input and holding chambers, or such chambers shared in common, are provided fluidly connected to the thermal arrays of the invention. An example of such a platform is shown in Figure 7.

Figure 6 shows a cross-sectional view of the platform of Figure 5. Heating element **604** is shown on the surface of thermal regulation layer substrate **607**, and fluidic manifold layer **602** containing microfluidic structures including microchannels **605** in substrate layer **603** are pressed together in place using fiducial registers as shown in Figures 1 and 2. Thermal conductive layer **606** is optionally included between the fluidic manifold layer and the thermal regulation layer to increase thermal conductivity and heat transfer to the fluid in microchannels **605**. An insulation space **601** having a volumetric capacity of from about 0.3 to about 3cm³ is advantageously positioned in fluidic manifold layer **602** above the

position of the heating element 604 in thermal regulation layer 607. This insulation space is optionally enclosed by cover 600.

5 In some embodiments of the invention, the platform comprises a single thermal array. It will be recognized by those with skill in the art that such embodiments are useful for multiplex assay of a single sample or assays of multiple samples. Platforms of the invention are provided having, *for example*, multiple embodiments of the thermal arrays as described herein, in fluid communication with one or a multiplicity of sample entry ports. Thus, in more preferred embodiments, the platforms of the invention comprise a multiplicity of such arrays laid out on the platform surface as exemplified in Figure 7.

10 In alternative embodiments, the fluidic manifold layer and thermal regulation layer are integrally micromachined onto a single substrate layer. In additional alternative embodiments, the thermal regulation layer comprises a platen that is in thermal contact with a fluidic microsystems platform of the invention, wherein the fluidic components such as microchannels are positioned to be in thermal contact with heating elements on the platen, most preferably using fiducials or other mechanical components that orient the platform and platen with one another.

In alternative embodiments, the thermal regulating layer is a mechanical platen, in which the microfluidic components are positioned in thermal contact with heating elements on the platen. A platen as the term is used herein is in certain embodiments a circuit board having electrical components mounted and soldered thereupon. In its simplest form, the electrical components are passive and consist primarily of resistors in defined locations on the platen. Heat is produced using such resistors because power is dissipated as heat when a voltage is applied across a resistor. The heat dissipation is proportional to the square of the applied voltage divided by the resistance of the resistor.

20 In certain embodiments, the platen comprises a multiplicity of resistors that share a common ground but that have different input wires so that different voltages can be applied and different temperatures obtained in microfluidics components placed proximate to each of the resistors. Typically, the electrical signal is distributed from the micromanipulation device to the platen through a slip-ring assembly, as described more fully in co-owned U.S. Patent No. 6,063,589, incorporated by reference. However, as the

30

multiplicity of resistors increases, the required number of slips can be impractical. For these embodiments, platens comprising integrated circuits, microprocessors and other "active" components are advantageously utilized.

The following Examples are intended to further illustrate certain preferred
5 embodiments of the invention and are not limiting in nature.

EXAMPLE 1

Microplatform Disk for DNA Hybridization

10 A series of hybridization reactions performed to determine the optimum hybridization stringency conditions between a probe molecule and a specific gene sequence is performed using the microsystems platform shown in Figure 4. A denatured hybridization mixture comprising the probe, the specific gene sequence, salts, buffers, detergents and hybridization facilitating agents such as dimethylformamide is applied to
15 fluid holding chamber 401 at rest. The platform is then rotated at a first rotation speed sufficient to overcome capillary microvalve 404 and the hybridization solution traverses microchannels 405 and is deposited in substantially equal volumes into hybridization chambers 406. Heating elements 407 are independently operated at a series of incrementally different and increasing temperatures, so that hybridization is achieved over a range of
20 temperatures from ambient to a temperature at which no hybridization occurs. After the hybridization mixture is incubated in hybridization chambers 406 for a time sufficient for hybridization to have proceeded to completion under the temperature conditions in each chamber, the platform is rotated at a second rotation speed higher than the first rotation speed, and the hybridization reaction mixtures from each hybridization chamber are
25 transferred to detection chambers 410. The extent of hybridization is analyzed in each detection chamber using conventional methods, for example, absorbance at 260nm; in this embodiment, the portion of the platform comprising detection chambers 410 is transparent to ultraviolet light. The temperature conditions yielding the greatest extent of hybridization are determined thereby.

30

EXAMPLE 2**Microplatform Disk for DNA Amplification**

An amplification reaction is performed on the microsystems platform disclosed in Figures 5 and 6 as follows. While the disk is stationary, 10 μ L of a fluid reaction mixture containing template DNA, PCR amplification primers, deoxynucleotide triphosphates, and thermostable polymerase in a buffer solution in which the reaction may proceed are applied to fluid input port **500**. As the fluid fills fluid holding chamber **501** air is displaced through air displacement channels **502** and **507**; in this example, **501** has a diameter of 0.4 cm and a depth of 0.3 cm and 10 μ L fills approximately 25% of the volumetric capacity of fluid holding chamber **501**. Fluid also flows into microchannel **503** until it reaches the capillary microvalve **504** or optional sacrificial valve **504**. Once loaded, the platform is briefly rotated at about 3000rpm to overcome the capillary microvalve, or optionally the sacrificial valve is opened, and then the rotational speed is lowered to about 590 rpm. At this rotational speed, fluid flows through fluid microchannel **505** at a rate of about 6nL/sec, as the microchannel has a hydraulic diameter of 50 μ m and a overall length of approximately 20cm. At this rate, it takes approximately 30min for the 10 μ L reaction mixture to traverse the thermal array **520** and be deposited in collection chamber **506**. As shown in Figure 5, traversal of the thermal array subjects the fluid to 30 cycles of alternative temperatures, equivalent to 30 cycles of PCR as conventionally performed.

It should be understood that the foregoing disclosure emphasizes certain specific embodiments of the invention and that all modifications or alternatives equivalent thereto are within the spirit and scope of the invention.

What is claimed is:

1. A centripetally-motivated microsystems platform comprising:
 - a) a rotatable platform comprising a substrate having a surface comprising one or a multiplicity of microchannels embedded therein and defining a longitudinal path across the surface of the platform;
 - b) a sample input port comprising a depression in the first surface having a volumetric capacity of about 1 to about 200 μ L;
 - c) a collection chamber comprising a depression in the first surface having a volumetric capacity of about 1 to about 200 μ L;wherein the sample input port and collection chamber are fluidly connected to the microchannels;
 - d) one or a multiplicity of heating elements comprising at least one region of the platform surfacewherein at least a portion of the longitudinal path of the microchannels is contained within the region of the platform surface comprising the heating elements;wherein a volume of a fluid within the microchannels of the platform is moved through said microchannels by centripetal force arising from rotational motion of the platform for a time and a rotational velocity sufficient to move the fluid through the microchannels, andwherein a fluid contained within the portion of the longitudinal path of the microchannels contained within the region of the platform surface comprising a heating element has a temperature greater than the ambient temperature of the platform.
2. A microsystem platform of claim 1 having one sample input port and a multiplicity of microchannels, wherein the sample input port is fluidly connected to each of the microchannels.
3. A microsystem platform of claim 1 having a multiplicity of sample input ports and a multiplicity of microchannels, wherein each microchannel is fluidly connected to a sample input port.

4. A microsystem platform of claim 1 having one collection chamber and a multiplicity of microchannels, wherein the collection chamber is fluidly connected to each of the microchannels.
- 5 5. A microsystem platform of claim 1 having a multiplicity of collection chambers and a multiplicity of microchannels, wherein each microchannel is fluidly connected to a collection chamber.
- 10 6. A microsystems platform of claim 1 wherein the heating element comprises a rectangular portion of the surface of the platform.
7. A microsystem platform of claim 1 wherein the heating element comprises a wedge-shaped portion of the surface of the platform.
- 15 8. A microsystem platform of claim 7, wherein the wedge-shaped portion is arrayed on the platform so that the longer annular diameter is farther from the center of the platform than the shorter annular diameter.
- 20 9. A microsystem platform of claim 1 that is a circular disk.
10. The microsystem platform of Claim 1, wherein the microsystem platform is constructed of an material selected from the group consisting of an organic material, an inorganic material, a crystalline material and an amorphous material.
- 25 11. The microsystem platform of Claim 10, wherein the microsystem platform further comprises a material selected from the group consisting of silicon, silica, quartz, a ceramic, a metal or a plastic.
- 30 12. The microsystem platform of Claim 9, wherein the microsystem platform is a circular disk having a radius of about 1 to about 25cm.

13. The microsystem platform of Claim 1, wherein the microsystem platform has a thickness of about 0.1 to 100mm, and wherein the cross-sectional dimension of the microchannels embedded therein is less than 500 μ m and from 1 to 90 percent of said cross-sectional dimension of the platform.

5

14. The microsystem platform of Claim 1, wherein the microsystem platform further comprises a multiplicity of air channels, exhaust air ports and air displacement channels.

10

15. The microsystems platform of Claim 1 wherein the microchannels are arrayed linearly from the center of the platform to the periphery.

16. The microsystems platform of Claim 1 wherein the microchannels are arrayed concentrically from the center of the platform to the periphery.

15

17. The microsystem platform of Claim 1, wherein the heating element comprises a resistive heater element.

18. The microsystem platform of claim 17, wherein the resistive heater element comprises in combination:

20

- a) an electrically inert substrate capable of being screen printed with a conductive ink and a resistive ink;
 - b) a conductive ink screen-printed in a pattern;
 - c) a resistive ink screen-printed in a pattern over the conductive ink pattern
- wherein the resistive ink is in electrical contact with the conductive ink and wherein an electrical potential applied across the conductive ink causes current to flow across the resistive ink wherein the resistive ink produces heat.

25

19. The microsystem platform of claim 18 wherein the resistive heater element further comprises

30

d) a dielectric ink screen-printed over the resistive ink pattern and conductive ink pattern.

5 20. A microsystem platform according to claim 1 comprising a multiplicity of heating elements.

10 21. A microsystem platform according to claim 20 wherein the multiplicity of heating elements comprises a pair of heating elements placed adjacent to one another on the surface of the platform.

22. A microsystem platform according to claim 21, wherein the adjacent heating elements are immediately adjacent to one another.

15 23. A microsystems platform according to claim 21, wherein the adjacent heating elements are separated by an unheated portion of the platform that is no wider than the width of one of the adjacent heating elements.

20 24. A microsystems platform according to claim 21, 22 or 23, wherein a portion of the longitudinal path of the microchannels is contained within the region of the platform surface comprising each of the heating elements.

25 25. A microsystem platform according to claim 20 wherein the multiplicity of heating elements comprises three heating elements placed adjacent to one another on the surface of the platform.

26. A microsystem platform according to claim 25, wherein the adjacent heating elements are immediately adjacent to one another.

27. A microsystems platform according to claim 25, wherein one or both of the adjacent heating elements are separated by an unheated portion of the platform that is no wider than the width of one of the adjacent heating elements.

5 28. A microsystems platform according to claim 25, 26 or 27, wherein a portion of the longitudinal path of the microchannels is contained within the region of the platform surface comprising each of the heating elements

10 29. A microsystems platform according to claim 21, wherein the platform comprises a multiplicity of adjacent pairs of heating elements separated by a portion of the platform.

15 30. A microsystems platform according to claim 21, wherein the platform comprises a multiplicity of adjacent three heating elements separated by an unheated portion of the platform.

31. A microsystem platform according to claim 20, wherein the multiplicity of heating elements comprise a thermal array.

20 32. A microsystem platform according to claim 32, wherein the thermal array comprises a single heating element.

25 33. A microsystem platform according to claim 32, wherein the thermal array comprises a multiplicity of heating elements.

34. A centripetally-motivated fluid micromanipulation apparatus that is a combination of
a microsystem platform according to claim 1, and

a micromanipulation device, comprising a base, a rotating means, a power supply and user interface and operations controlling means, wherein the rotating means is operatively linked to the microsystem platform and in rotational contact therewith

5 wherein a volume of a fluid within the microchannels of the platform is moved through said microchannels by centripetal force arising from rotational motion of the platform for a time and a rotational velocity sufficient to move the fluid through the microchannels.

10 35. The apparatus of Claim 34, wherein the rotating means of the device is an electric motor.

36. The apparatus of Claim 34, wherein the device comprises a rotational motion controlling means for controlling the rotational acceleration and velocity of the microsystem platform.

15 37. A microsystems platform of claim 1, wherein the microchannels, sample input port and collection chamber are contained in the surface of the platform, and the heating elements comprise a platen in thermal contact with the microsystems platform.

20 38. A microsystems platform according to claim 24, wherein each of the heating elements is operated at a temperature greater than ambient temperature of the platform.

25 39. A microsystems platform of claim 38, wherein each of the heating elements is operated at a temperature different from the other heating element and greater than the ambient temperature of the platform.

40. A microsystems platform according to claim 28, wherein each of the heating elements is operated at a temperature greater than ambient temperature of the platform.

41. A microsystems platform of claim 40, wherein each of the heating elements is operated at a temperature different from the other heating element and greater than the ambient temperature of the platform.

5 42. A microsystems platform of claim 38 or 39 wherein one of the heating elements is operated at a temperature of from about 80°C to about 98°C and the other heating element is operated at a temperature of about 65°C to about 75°C.

10 43. A microsystems platform of claim 40 or 41 wherein one of the heating elements is operated at a temperature of from about 80°C to about 98°C, one of the heating elements is operated at a temperature of from about 40°C to about 65°C, and the other heating element is operated at a temperature of about 60°C to about 75°C.

15 44. A microsystems platform according to claim 43, wherein the heating element operated at a temperature of from about 60°C to about 75°C is positioned in between the other two heating elements.

20 45. A microsystems platform according to claim 44, wherein the portion of the longitudinal extent of the microchannels is greater in the region of the platform surface comprising the heating element operated at a temperature of from about 60°C to about 75°C than the portion of the microchannels in the regions comprising either of the other two heating elements.

25 46. A microsystems platform according to claim 1, wherein the portion of the longitudinal extent of the microchannels are linear, curved, spiral, zig-zag or meandering.

47. A microsystems platform according to claim 1, wherein the surface of the platform comprising the collection chamber is optically transparent.

48. An apparatus of Claim 34, wherein the micromanipulation apparatus further comprises an optical, radiometric or fluorescence detector.

5 49. An apparatus of claim 48, wherein the detector is brought into alignment with the collection chamber on the platform by rotational motion of the microsystem platform.

10 50. The apparatus of Claim 49, wherein the detector is an optical detector comprising a light source and a photodetector.

11 51. A method for performing a biological or biochemical reaction, comprising the steps of:

- 12 a) applying a volume of a fluid comprising a biological sample to a microsystem platform of claim 1, wherein the platform is stationary;
- 15 b) rotating the platform at a rotational speed sufficient to motivate fluid flow through the microchannel;
- 16 c) heating the fluid in the microchannel as it traverses a portion of the platform comprising a heating element it to a temperature wherein the biological or biochemical reaction takes place; and
- 20 d) recovering from the microsystems platform a product of the biological or biochemical reaction.

25 52. A method according to claim 51, wherein the biological sample comprises a nucleic acid species.

30 53. A method according to claim 52, wherein the biological or biochemical reaction is nucleic acid hybridization, polymerase chain reaction or ligase chain reaction.

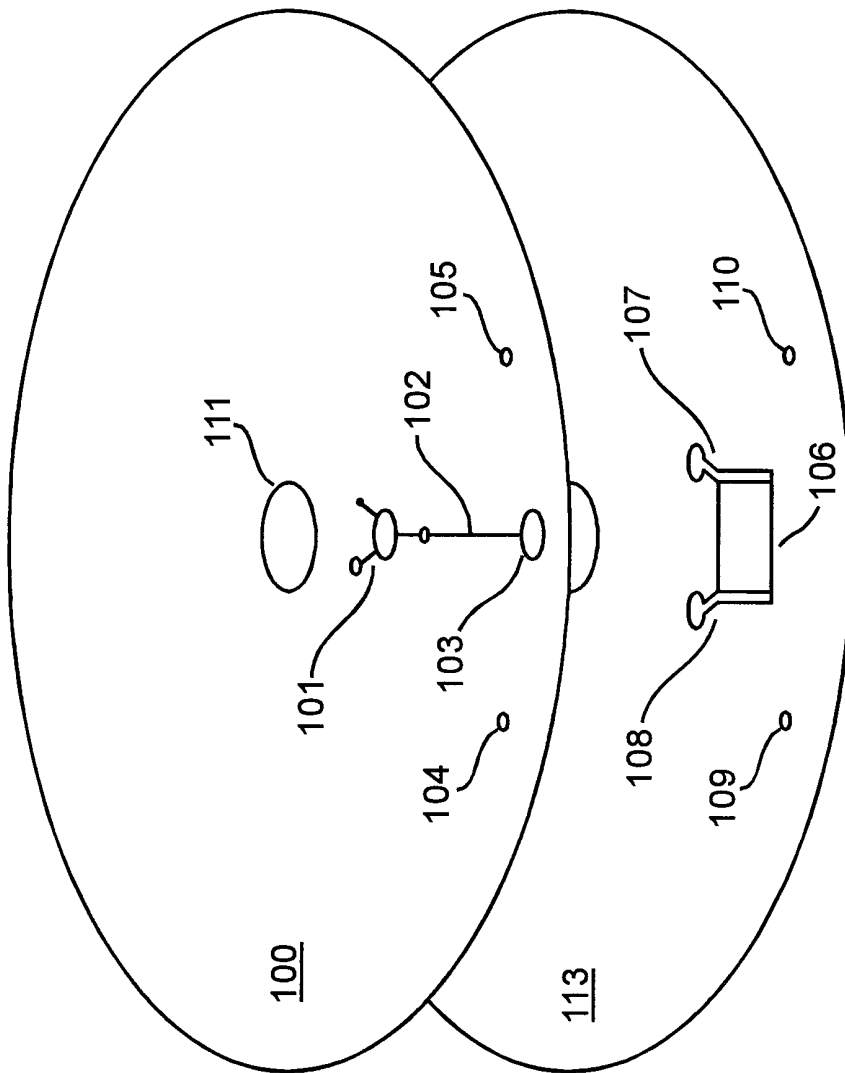

Fig. 1

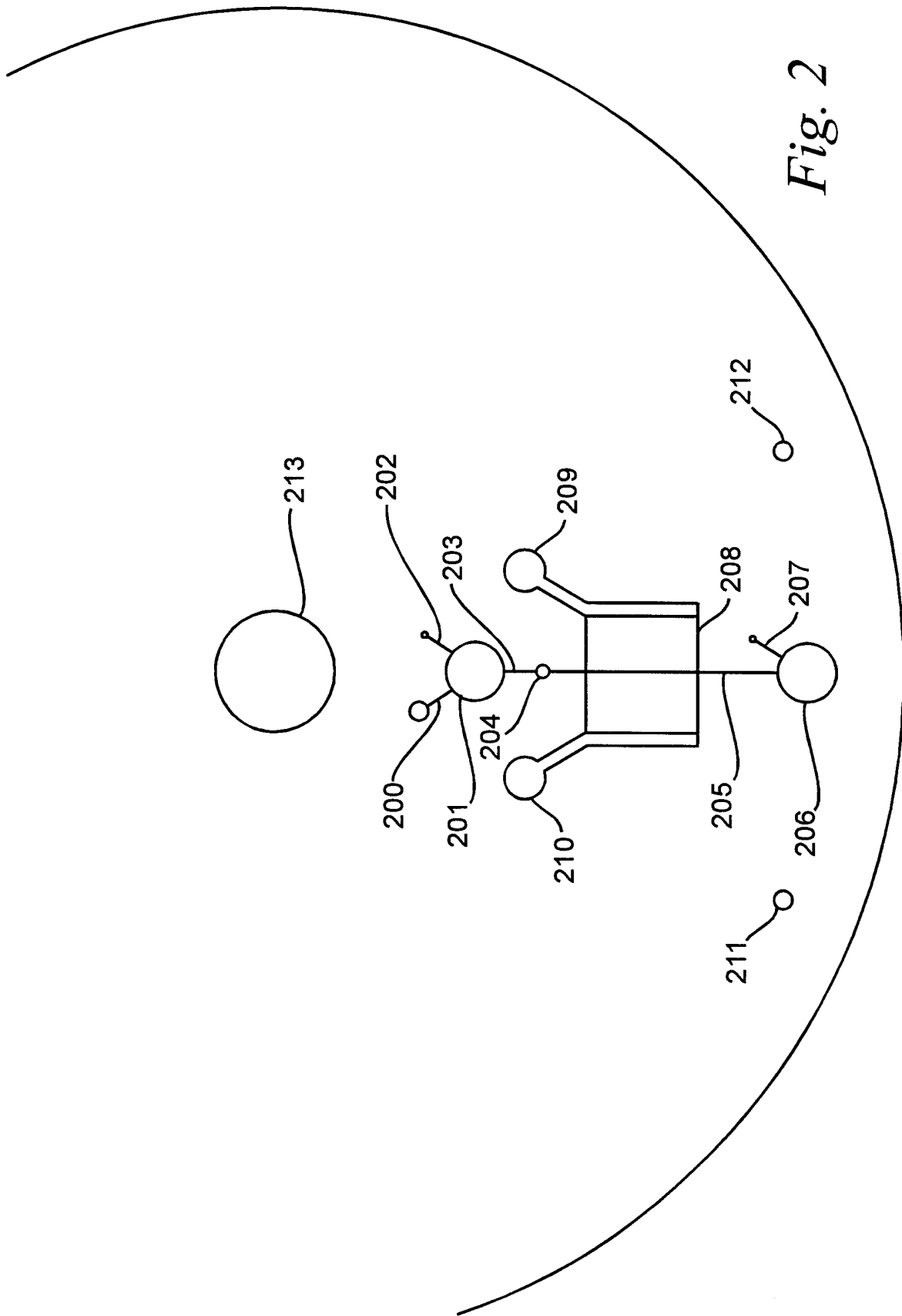

Fig. 2

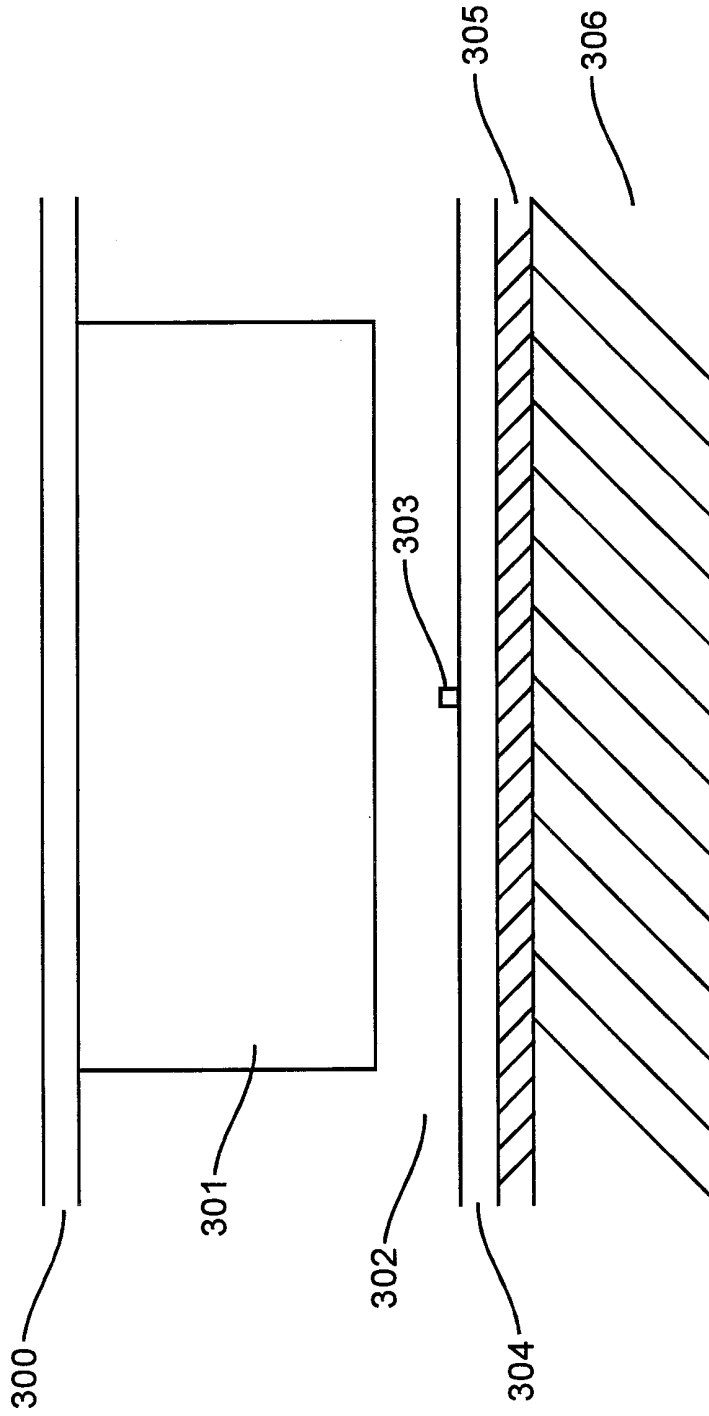

Fig. 3

4/7

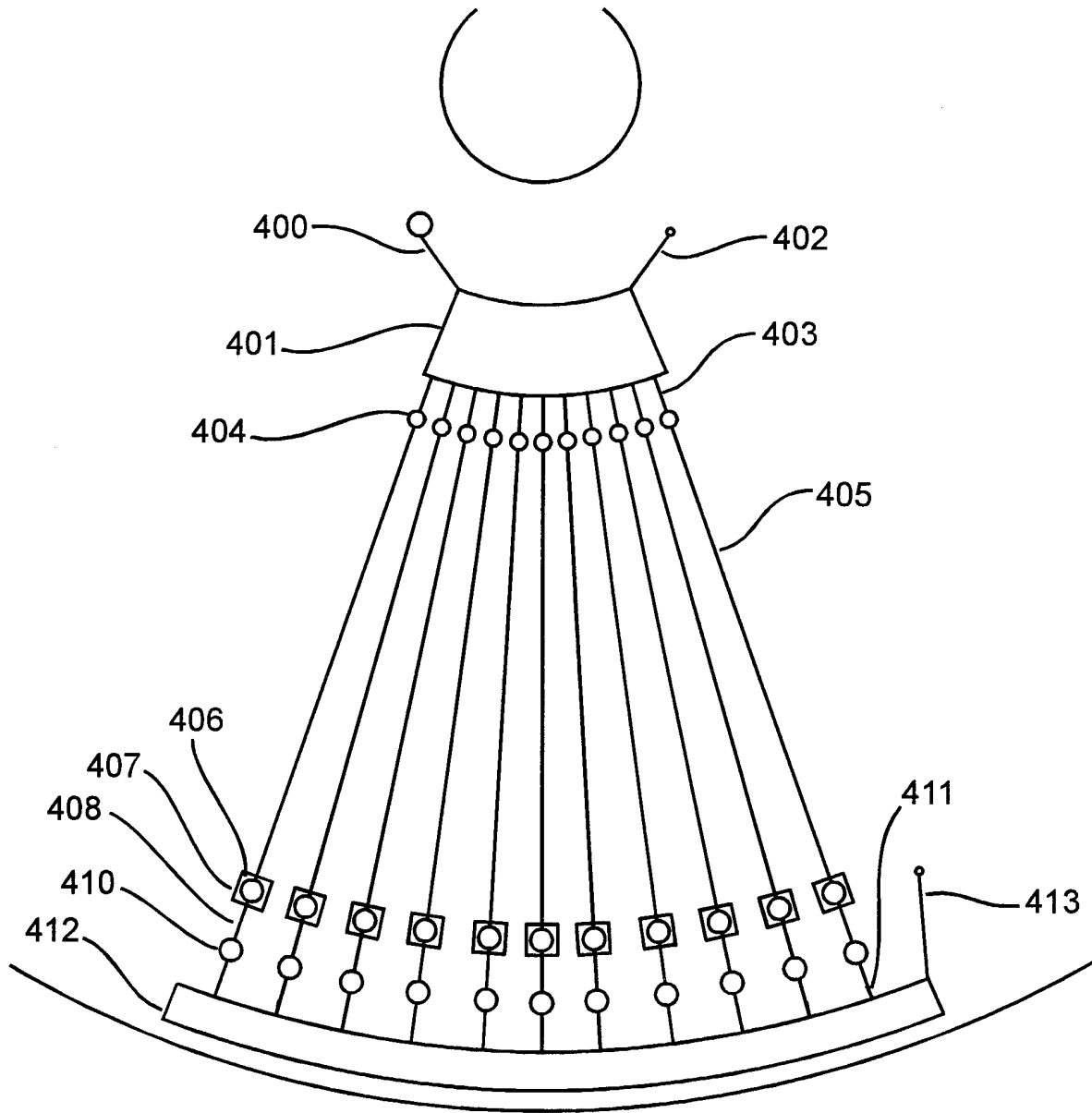

Fig. 4

5/7

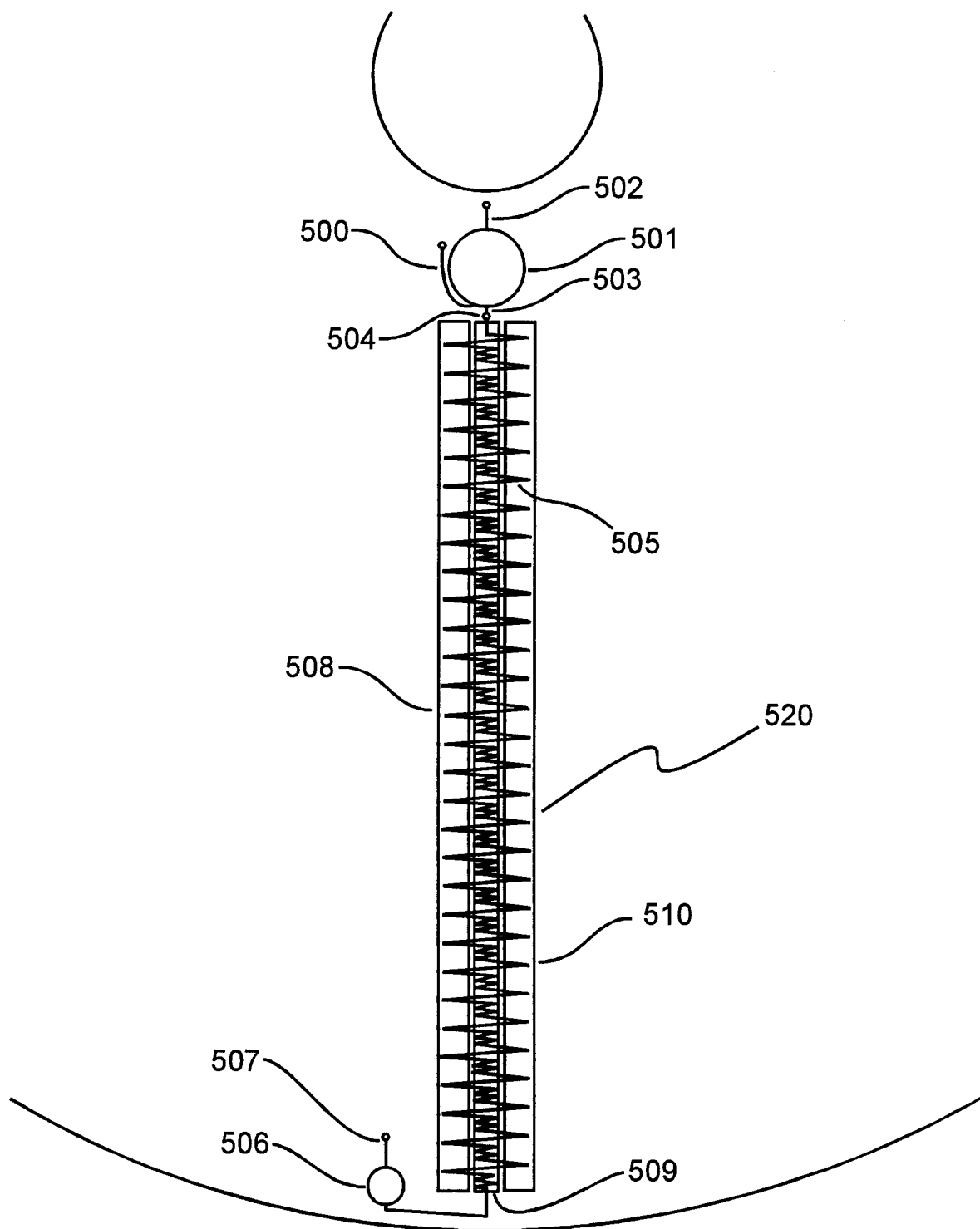

Fig. 5

SUBSTITUTE SHEET (RULE 26)

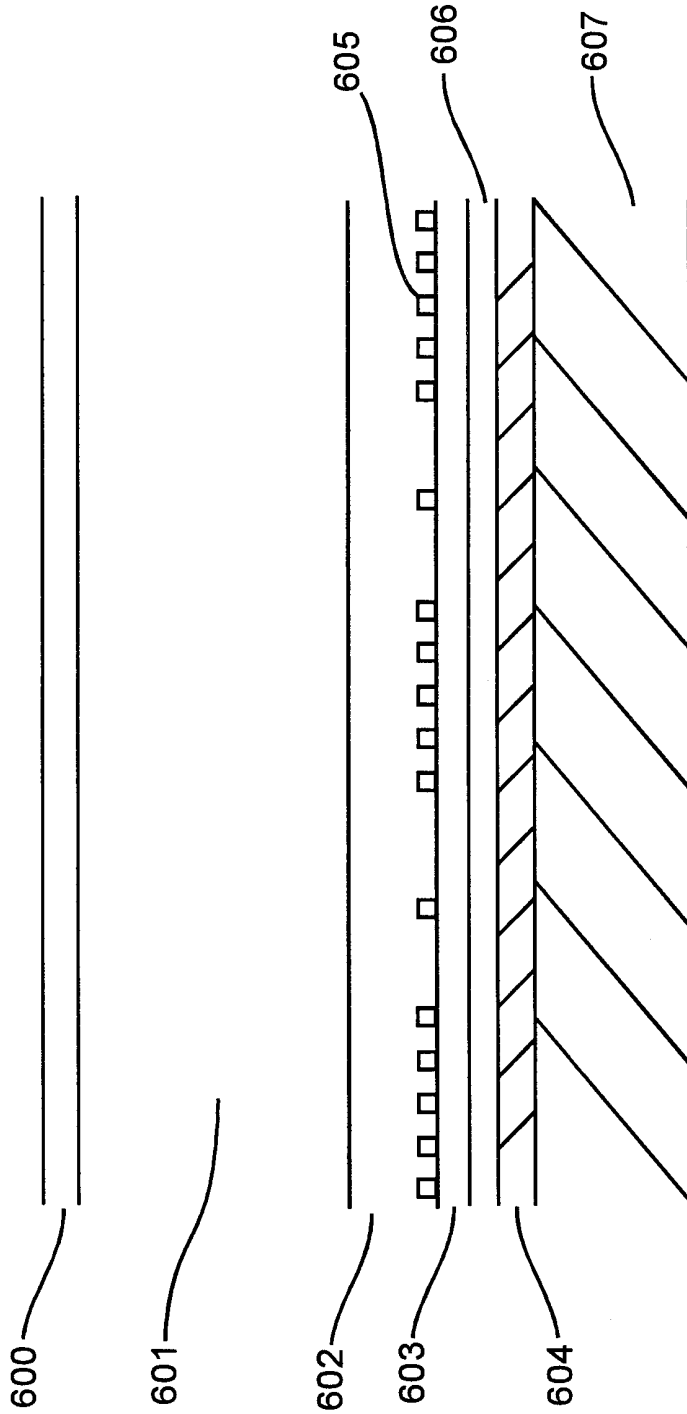

Fig. 6

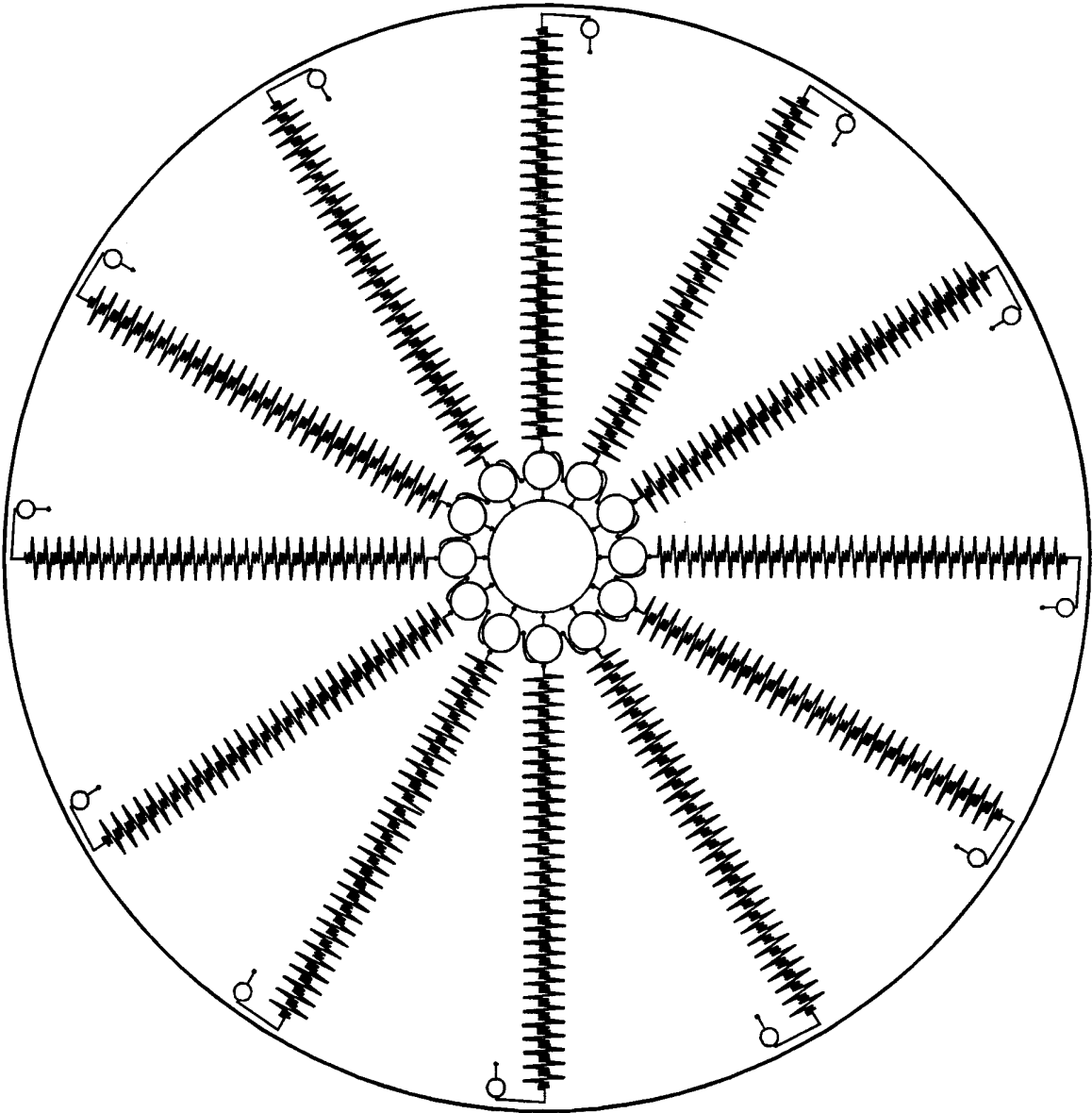

Fig. 7

INTERNATIONAL SEARCH REPORT

International Application No

PCT/US 00/13131

A. CLASSIFICATION OF SUBJECT MATTER

IPC 7 B01L3/00 //B01J19/00,C12Q1/68,G01N21/17,G01N21/33,G01N21/75

According to International Patent Classification (IPC) or to both national classification and IPC

B. FIELDS SEARCHED

Minimum documentation searched (classification system followed by classification symbols)

IPC 7 B01L B01J C12Q G01N

Documentation searched other than minimum documentation to the extent that such documents are included in the fields searched

Electronic data base consulted during the international search (name of data base and, where practical, search terms used)

EPO-Internal, WPI Data, PAJ

C. DOCUMENTS CONSIDERED TO BE RELEVANT

Category °	Citation of document, with indication, where appropriate, of the relevant passages	Relevant to claim No.
Y	<p>WO 98 53311 A (GAMERA BIOSCIENCE CORP) 26 November 1998 (1998-11-26)</p> <p>page 15, line 4 -page 55, line 20 page 79, line 6 -page 87, line 1 figures 1-38</p> <p style="text-align: center;">---</p> <p style="text-align: center;">-/--</p>	<p>1-6, 9-20, 23, 24, 31, 33-41, 46-48, 51-53</p>

Further documents are listed in the continuation of box C.

Patent family members are listed in annex.

° Special categories of cited documents :

- "A" document defining the general state of the art which is not considered to be of particular relevance
- "E" earlier document but published on or after the international filing date
- "L" document which may throw doubts on priority claim(s) or which is cited to establish the publication date of another citation or other special reason (as specified)
- "O" document referring to an oral disclosure, use, exhibition or other means
- "P" document published prior to the international filing date but later than the priority date claimed

- "T" later document published after the international filing date or priority date and not in conflict with the application but cited to understand the principle or theory underlying the invention
- "X" document of particular relevance; the claimed invention cannot be considered novel or cannot be considered to involve an inventive step when the document is taken alone
- "Y" document of particular relevance; the claimed invention cannot be considered to involve an inventive step when the document is combined with one or more other such documents, such combination being obvious to a person skilled in the art.
- "&" document member of the same patent family

Date of the actual completion of the international search

31 August 2000

Date of mailing of the international search report

06/09/2000

Name and mailing address of the ISA

European Patent Office, P.B. 5818 Patentlaan 2
NL - 2280 HV Rijswijk
Tel. (+31-70) 340-2040, Tx. 31 651 epo nl,
Fax: (+31-70) 340-3016

Authorized officer

Koch, A

INTERNATIONAL SEARCH REPORT

Intern: al Application No

PCT/US 00/13131

C.(Continuation) DOCUMENTS CONSIDERED TO BE RELEVANT		
Category °	Citation of document, with indication, where appropriate, of the relevant passages	Relevant to claim No.
Y	<p>WO 98 54580 A (HERST C V TAYLOR) 3 December 1998 (1998-12-03)</p> <p>page 1, line 16 -page 2, line 4 page 2, line 25 -page 3, line 2 page 6, line 21 -page 7, line 6 page 7, line 26 -page 7, line 30 page 9, line 20 -page 11, line 19 figures 1,2</p> <p style="text-align: center;">---</p>	<p>1-6, 9-20,23, 24,31, 33-41, 46-48, 51-53</p>
X	<p>WO 97 21090 A (GAMERA BIOSCIENCE) 12 June 1997 (1997-06-12)</p> <p>page 1, line 12 -page 1, line 23 page 4, line 27 -page 6, line 16 page 9, line 13 -page 14, line 2 page 17, line 24 -page 18, line 26 page 22, line 5 -page 22, line 17 page 24, line 21 -page 28, line 9 page 30, paragraphs 1,2 page 31, paragraph 3 -page 32, line 6 page 52, line 3 -page 52, line 20 page 65, line 12 -page 71, line 24 figures 1-21</p> <p style="text-align: center;">---</p>	<p>51</p>
Y	<p>EP 0 693 560 A (BECTON DICKINSON CO) 24 January 1996 (1996-01-24)</p> <p>column 3, line 12 -column 5, line 30 column 8, line 1 -column 9, line 21 column 9, line 31 -column 9, line 45 column 10, line 52 -column 11, line 47 column 12, line 37 -column 13, line 2 column 13, line 41 -column 14, line 44 column 15, line 14 -column 15, line 21 column 15, line 39 -column 15, line 45 column 16, line 2 -column 16, line 6 column 16, line 16 -column 16, line 21 column 16, line 49 -column 17, line 27 column 18, line 38 -column 18, line 42 column 23, line 17 -column 23, line 21 figures 1-21</p> <p style="text-align: center;">-----</p>	<p>52,53</p>
A	<p>EP 0 693 560 A (BECTON DICKINSON CO) 24 January 1996 (1996-01-24)</p> <p>column 3, line 12 -column 5, line 30 column 8, line 1 -column 9, line 21 column 9, line 31 -column 9, line 45 column 10, line 52 -column 11, line 47 column 12, line 37 -column 13, line 2 column 13, line 41 -column 14, line 44 column 15, line 14 -column 15, line 21 column 15, line 39 -column 15, line 45 column 16, line 2 -column 16, line 6 column 16, line 16 -column 16, line 21 column 16, line 49 -column 17, line 27 column 18, line 38 -column 18, line 42 column 23, line 17 -column 23, line 21 figures 1-21</p> <p style="text-align: center;">-----</p>	<p>1-5, 9-12,15, 20,21, 24,28, 34,35, 37-40, 46-53</p>

INTERNATIONAL SEARCH REPORT

information on patent family members

International Application No

PCT/US 00/13131

Patent document cited in search report		Publication date	Patent family member(s)	Publication date
WO 9853311	A	26-11-1998	AU 7591998 A EP 0983504 A	11-12-1998 08-03-2000
WO 9854580	A	03-12-1998	US 5922288 A AU 7707898 A US 5935858 A	13-07-1999 30-12-1998 10-08-1999
WO 9721090	A	12-06-1997	AU 702403 B AU 1283397 A CA 2239613 A CN 1208464 A EP 0865606 A NO 982563 A AU 4144897 A EP 0917648 A WO 9807019 A	18-02-1999 27-06-1997 12-06-1997 17-02-1999 23-09-1998 05-08-1998 06-03-1998 26-05-1999 19-02-1998
EP 0693560	A	24-01-1996	US 5639428 A AU 2331095 A BR 9503364 A CA 2152307 A JP 8062225 A SG 32408 A	17-06-1997 01-02-1996 27-02-1996 20-01-1996 08-03-1996 13-08-1996