

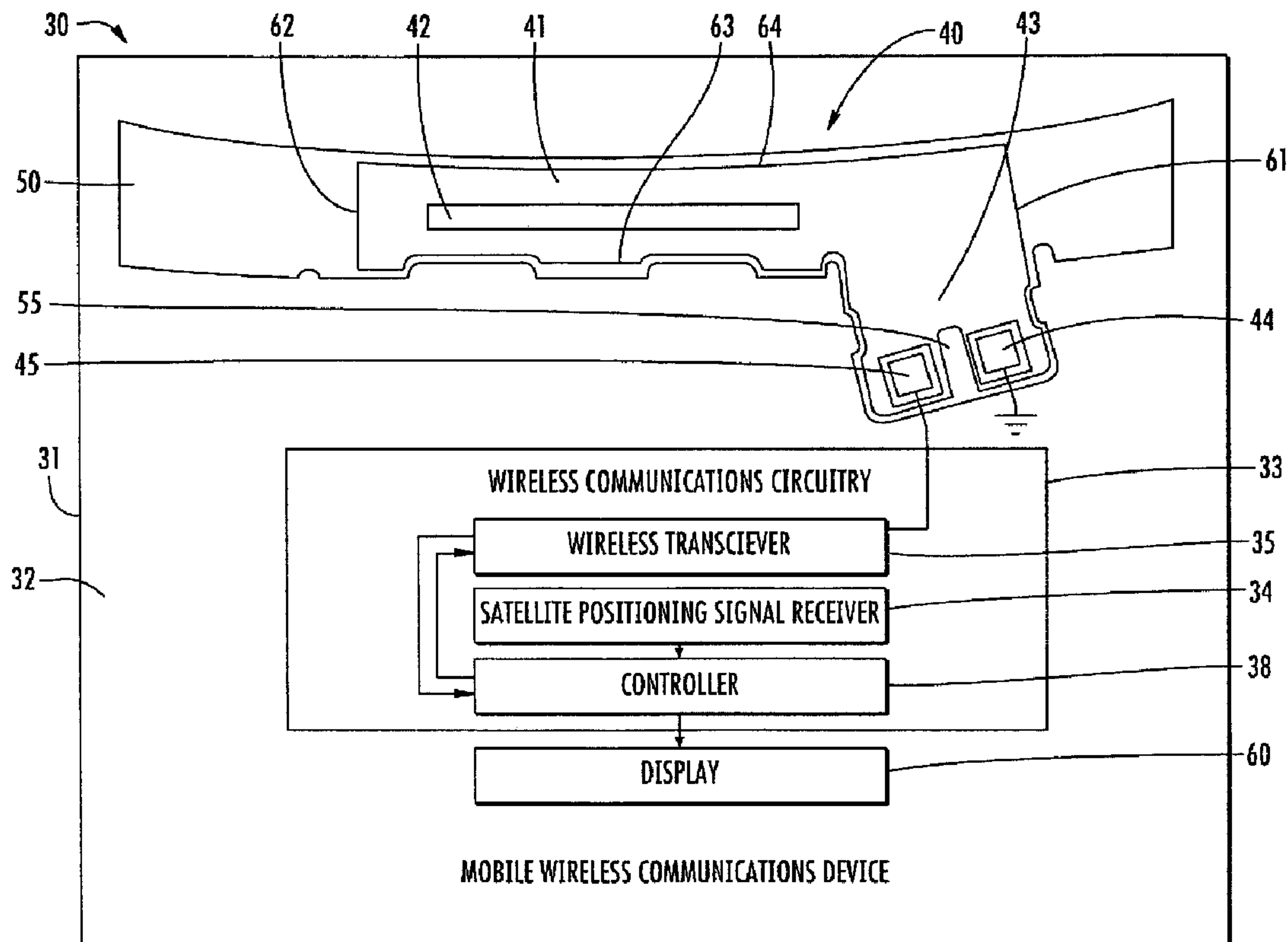

(22) **Date de dépôt/Filing Date:** 2012/04/05
 (41) **Mise à la disp. pub./Open to Public Insp.:** 2012/10/06
 (45) **Date de délivrance/Issue Date:** 2015/07/07
 (30) **Priorité/Priority:** 2011/04/06 (US61/472,289)

(51) **Cl.Int./Int.Cl.** *H01Q 13/10* (2006.01),
H01Q 1/38 (2006.01), *H01Q 9/04* (2006.01),
H04W 88/02 (2009.01)
 (72) **Inventeurs/Inventors:**
 YANG, SHING LUNG STEVEN, US;
 BADARUZZAMAN, FIRASS MIRZA, US;
 SZCZYPINSKI, DAVID KAZMIERZ, US
 (73) **Propriétaire/Owner:**
 BLACKBERRY LIMITED, CA
 (74) **Agent:** RIDOUT & MAYBEE LLP

(54) **Titre : DISPOSITIF DE COMMUNICATION SANS FIL MOBILE MUNI D'UN ENSEMBLE D'ANTENNE AVEC UNE BASE CONDUCTIVE D'ELECTRICITE ENFERMANT UNE FENTE ALLONGEE ET METHODES ASSOCIEES**
 (54) **Title: MOBILE WIRELESS COMMUNICATIONS DEVICE HAVING ANTENNA ASSEMBLY WITH ELECTRICALLY CONDUCTIVE BASE ENCLOSING AN ELONGATE SLOT AND ASSOCIATED METHODS**



(57) **Abrégé/Abstract:**

A mobile wireless communications device may include a housing carrying a circuit board and wireless communications circuitry. An antenna assembly is carried by the housing and coupled to the wireless communications circuitry. The antenna assembly may

(57) Abrégé(suite)/Abstract(continued):

include an electrically conductive base having a rectangular shape with opposing first and second ends and opposing first and second sides extending between the first and second ends. The electrically conductive base may have an elongate slot therein extending within a medial portion thereof and contained within the opposing first and second ends and the opposing first and second sides. The antenna assembly also may include an electrically conductive feed arm extending outwardly from the first side of the electrically conductive base adjacent the first end thereof. The electrically conductive feed arm may have a distal end with an antenna feed defined thereon.

Abstract of the Disclosure

A mobile wireless communications device may include a housing carrying a circuit board and wireless communications circuitry. An antenna assembly is carried by the housing and coupled to the wireless communications circuitry. The antenna assembly may include an electrically conductive base having a rectangular shape with opposing first and second ends and opposing first and second sides extending between the first and second ends. The electrically conductive base may have an elongate slot therein extending within a medial portion thereof and contained within the opposing first and second ends and the opposing first and second sides. The antenna assembly also may include an electrically conductive feed arm extending outwardly from the first side of the electrically conductive base adjacent the first end thereof. The electrically conductive feed arm may have a distal end with an antenna feed defined thereon.

**MOBILE WIRELESS COMMUNICATIONS DEVICE HAVING ANTENNA ASSEMBLY
WITH ELECTRICALLY CONDUCTIVE BASE ENCLOSING AN ELONGATE SLOT AND
ASSOCIATED METHODS**

Technical Field

[0002] The present disclosure generally relates to the field of wireless communications systems, and, more particularly, to mobile wireless communications devices and related methods.

Background

[0003] Cellular communication systems continue to grow in popularity and have become an integral part of both personal and business communications. Cellular telephones allow users to place and receive phone calls almost anywhere they travel. Moreover, as cellular telephone technology is improved, so too has the functionality of cellular devices. For example, many cellular devices now incorporate Personal Digital Assistant (PDA) features such as calendars, address books, task lists, calculators, memo and writing programs, etc. These multi-function devices usually allow users to wirelessly send and receive electronic mail (email) messages and access the Internet via a cellular network and/or a wireless local area network (WLAN), for example.

[0004] As the functionality of cellular devices continues to increase, so too does demand for smaller devices that are easier and more convenient for users to carry. Nevertheless, the move towards multi-functional devices makes miniaturization more difficult as the requisite number of installed components increases. Indeed, the typical cellular device may include

41105-CA-PAT

several antennas, for example, a cellular antenna, a global positioning system antenna, and a WiFi IEEE 802.11g antenna. These antennas may comprise external antennas and internal antennas.

[0005] Generally speaking, internal antennas allow cellular devices to have a smaller footprint. Moreover, they are also preferred over external antennas for mechanical and ergonomic reasons. Internal antennas are also protected by the cellular device's housing and therefore tend to be more durable than external antennas. External antennas may be cumbersome and may make the cellular device difficult to use, particularly in limited-space environments. Yet, one potential drawback of typical internal antennas is that they are in relatively close proximity to the user's head when the cellular device is in use, thereby increasing the specific absorption rate (SAR). Yet more, hearing aid compatibility (HAC) may also be affected negatively. Also, other components within the cellular device may cause interference with or may be interfered by the internal antenna.

Brief Description of the Drawings

[0006] FIG. 1 is a top plan view of a mobile wireless communications device including an antenna assembly in accordance with one example embodiment.

[0007] FIG. 2 is a schematic block diagram of the device of FIG. 1.

[0008] FIG. 3 is a perspective view of the antenna assembly installed in the mobile wireless communications device of FIG. 1.

[0009] FIG. 4 is an S-parameter plot of the antenna assembly of FIG. 2.

[0010] FIG. 5 is a first side of a two dimensional radiation pattern of the antenna assembly of FIG. 2 along the X-Y axis while radiating at a first frequency.

[0011] FIG. 6 is a second side of a two dimensional radiation pattern of the antenna assembly of FIG. 2 along the X-Y axis while radiating at a first frequency.

[0012] FIG. 7 is a first side of a two dimensional radiation pattern of the antenna assembly of FIG. 2 along the Y-Z axis while radiating at a first frequency.

[0013] FIG. 8 is a second side of a two dimensional radiation pattern of the antenna assembly of FIG. 2 along the Y-Z axis while radiating at a first frequency.

[0014] FIG. 9 is a first side of a two dimensional radiation pattern of the antenna assembly of FIG. 2 along the X-Z axis while radiating at a first frequency.

[0015] FIG. 10 is a second side of a two dimensional radiation pattern of the antenna assembly of FIG. 2 along the X-Z axis while radiating at a first frequency.

[0016] FIG. 11 is a first side of a two dimensional radiation pattern of the antenna assembly of FIG. 2 along the X-Y axis while radiating at a second frequency.

[0017] FIG. 12 is a second side of a two dimensional radiation pattern of the antenna assembly of FIG. 2 along the X-Y axis while radiating at a second frequency.

[0018] FIG. 13 is a first side of a two dimensional radiation pattern of the antenna assembly of FIG. 2 along the Y-Z axis while radiating at a second frequency.

[0019] FIG. 14 is a second side of a two dimensional radiation pattern of the antenna assembly of FIG. 2 along the Y-Z axis while radiating at a second frequency.

[0020] FIG. 15 is a first side of a two dimensional radiation pattern of the antenna assembly of FIG. 2 along the X-Z axis while radiating at a second frequency.

[0021] FIG. 16 is a second side of a two dimensional radiation pattern of the antenna assembly of FIG. 2 along the X-Z axis while radiating at a second frequency.

[0022] FIG. 17 is a schematic block diagram illustrating in more detail components that may be included in the mobile wireless communications device of FIG. 1.

Detailed Description

[0023] The present description is made with reference to the accompanying drawings, in which various embodiments are shown. However, many different embodiments may be used, and thus the description should not be construed as limited to the embodiments set forth herein. Rather, these embodiments are provided so that this disclosure will be thorough and complete. Like numbers refer to like elements throughout.

[0024] Generally speaking, a mobile wireless communications device may include a housing, a circuit board carried by the housing, and wireless communications circuitry carried by the circuit board. The mobile wireless communications device may comprise an antenna assembly carried by the housing and coupled to the wireless communications circuitry. The antenna assembly may comprise an electrically conductive base having a rectangular shape with opposing first and second ends and opposing first and second sides extending between the first and

41105-CA-PAT

second ends. The electrically conductive base may have an elongate slot therein extending within a medial portion thereof and contained within the opposing first and second ends and the opposing first and second sides. The antenna assembly may include an electrically conductive feed arm extending outwardly from the first side of the electrically conductive base adjacent the first end thereof, and having a distal end with at least one antenna feed defined thereon. This antenna assembly is compact and easy to manufacture, yet provides the mobile wireless communications device with good performance over a plurality of operating frequency bands.

[0025] In some applications, the antenna assembly may comprise a flexible substrate mounting the electrically conductive base and the electrically conductive feed arm. This flexible substrate may comprise a planar base mounting portion spaced from the circuit board and mounting the electrically conductive base, and an arm mounting portion extending downwardly from the planar base mounting portion and mounting the electrically conductive feed arm.

[0026] The elongate slot may have a variety of configurations. For example, the elongate slot may be longitudinally offset from the first end and toward the second end of the electrically conductive base. In addition, the elongate slot may be centered between the first and second sides of the electrically conductive base. Further, the elongate slot may have a rectangular shape. Moreover, the elongate slot may have a width less than a third of a width of the electrically conductive base. Also, the elongate slot may have a length greater than half a length of the electrically conductive base.

41105-CA-PAT

The elongate slot may have a length greater than a corresponding length of the electrically conductive feed arm.

[0027] The at least one antenna feed may comprise first and second antenna feeds. In addition, the electrically conductive feed arm may have a slot therein extending through a medial portion between the first and second antenna feeds. Further, in some applications, the antenna assembly may be operable in a plurality of frequency bands.

[0028] Another aspect is directed to a method of making an antenna assembly for mobile wireless communications device comprising a housing, a circuit board carried by the housing, and wireless communications circuitry carried by the circuit board. The method may include forming an electrically conductive base having a rectangular shape with opposing first and second ends and opposing first and second sides extending between the first and second ends. The electrically conductive base may be formed to have an elongate slot therein extending within a medial portion thereof and contained within the opposing first and second ends and the opposing first and second sides. The method may also include forming an electrically conductive feed arm extending outwardly from the first side of the electrically conductive base adjacent the first end thereof, the electrically conductive feed arm being formed to have a distal end with at least one antenna feed defined thereon.

[0029] Referring initially to FIGS. 1-3, a mobile wireless communications device **30** according to the present disclosure is now described. The mobile wireless communications device **30** illustratively includes a housing **39** and a substrate **32**, for example, a printed circuit board (PCB) carried by the housing. The housing **39** has an upper portion and a lower portion. The

41105-CA-PAT

substrate **32** may be a rigid PCB, or may be a flexible substrate or PCB, for example. In some embodiments wherein a PCB is used, the PCB may be replaced by or used in conjunction with a metal chassis or other substrate, as will be appreciated by those skilled in the art and described in further detail below. The substrate **32** may include a conductive layer defining the ground plane. The substrate **32** may also include a dielectric layer carrying the conductive layer. The substrate **32** may have additional layers, as will be appreciated by those skilled in the art.

[0030] The mobile wireless communications device **30** includes wireless communications circuitry **33** carried by the housing **39**. The wireless communications circuitry **33** may include, for example, a wireless transceiver **35**. The wireless transceiver **35** may be a WiFi (IEEE 802.11) transceiver or a cellular transceiver, for example. The wireless communications circuitry **33** may also include, in some embodiments, a satellite positioning signal receiver **34**. The satellite positioning signal receiver **34** may be a Global Positioning System (GPS) satellite receiver, for example. Of course, the mobile wireless communications device **30** may not include a satellite positioning receiver, or may include additional receivers and/or transmitters, for example, near-field communications (NFC) receivers and/or transmitters and wireless local area network receivers (e.g. 802.xx, WiFi, WiMax). Thus, the satellite positioning receiver **34** or additional receivers and/or transmitters may not be part of the wireless communications circuitry **33**, as will be appreciated by those skilled in the art.

[0031] The mobile wireless communications device **30** further illustratively includes a display **60** and a plurality of control keys including an "off hook" (i.e., initiate phone call) key **61**, an "on hook" (i.e., discontinue phone call) key **62**, a menu key **63**, and a return or escape key **64**. Operation of the various device components and input keys, etc., will be described further below with reference to FIG. 4.

[0032] The wireless communications circuitry **33** may also include a controller **38** or processor. The controller **38** may cooperate with the other components, for example, the antenna assembly **40**, the satellite positioning signal receiver **34**, and the wireless transceiver **33** to coordinate and control operations of the mobile wireless communications device **30**. Operations may include mobile voice and data operations, including email and Internet data.

[0033] The antenna assembly **40** comprises a flexible substrate **50**. An electrically conductive base **41** is mounted on the flexible substrate **50**, for example, being a pattern of conductive traces thereon. The electrically conductive base **41** has a rectangular shape with opposing first and second ends **61-62** and opposing first and second sides **63-64** extending between the first and second ends in the illustrated embodiment. The first and second sides **63-64** have a length that is greater than the length of the first and second ends **61-62**. An elongate slot **42** is defined in a medial portion of the electrically conductive base **41**, and is contained within the opposing first and second ends **61-62** and the opposing first and second sides **63-64** in the illustrated embodiment.

[0034] The antenna assembly **40** includes an electrically conductive feed arm **43** extending outwardly from the first side

41105-CA-PAT

63 of the electrically conductive base **41** adjacent the first end **61** thereof and has a distal end with a first antenna feed **45** defined thereon. A second antenna feed **44** in the form of an antenna ground is also defined on the distal end of the electrically conductive feed arm **43**. The first antenna feed **45** is coupled to the wireless transceiver **35**, while the second antenna feed **44** is coupled to ground. An elongate slot extends through a medial portion of the electrically conductive feed arm **43** between the first and second antenna feeds **45, 44**.

[0035] This antenna assembly **40** advantageously allows operation in multiple bands. For example, the electrically conductive base **41** resonates at a first frequency, such as 1.57GHz, whereas the edges of the electrically conductive base that define the elongate slot **42** resonate at a second frequency that may be greater than the first frequency, such as 2.4GHz.

[0036] The elongate slot **42** is illustratively longitudinally offset from the first end **61** and toward the second end **62** of the electrically conductive base **41**. In addition, the elongate slot **42** is illustratively centered between the first and second sides of the electrically conductive base **41**. Further, the elongate slot **42** illustratively has a rectangular shape, with a width of less than a third of a width of the electrically conductive base **41**, and a length greater than half a length of the electrically conductive base. In addition, it should be noted that the elongate slot **42** illustratively has a length greater than a corresponding length of the electrically conductive feed arm **43**.

[0037] An S-parameter plot **71** of the antenna assembly **40** while radiating is shown in FIG. 4. Two dimensional radiation patterns **72-76** of the antenna assembly **40** while radiating at a first frequency are shown in FIGS. 5-10. In addition, two

dimensional radiation patterns **77-82** of the assembly **40** while radiating at a second frequency are shown in FIGS. 11-16.

[0038] With reference to FIG. 3, the flexible substrate **50** includes a planar base mounting portion **51** spaced from the circuit board **31** and mounting the electrically conductive base **41** (shown with dashed lines), and an arm mounting portion **52** extending downwardly from the planar base mounting portion and mounting the electrically conductive feed arm **43**. The arm mounting portion **53** may be folded such that the feed point **45** and ground point **44** couple with the circuit board **31**.

[0039] The present disclosure includes methods of making antenna assembly **40** for use in mobile wireless communications device **30**. The method includes forming an electrically conductive base **41** having a rectangular shape with opposing first and second ends **61-62** and opposing first and second sides **63-64** extending between the first and second ends. The electrically conductive base **41** is formed to have an elongate slot **42** therein extending within a medial portion thereof and contained within the opposing first and second ends **61-62** and the opposing first and second sides **63-64**. The method also includes forming an electrically conductive feed arm **43** extending outwardly from the first side **63** of the electrically conductive base **41** adjacent the first end **61** thereof. The electrically conductive feed arm **43** is formed to have a distal end with at least one antenna feed **45** defined thereon.

[0040] Example components of a mobile wireless communications device **1000** that may be used in accordance with the above-described embodiments are further described below with reference to FIG. 17. The device **1000** illustratively includes a housing **1200**, a keyboard or keypad **1400** and an output device **1600**. The

output device shown is a display **1600**, which may comprise a full graphic LCD. Other types of output devices may alternatively be utilized. A processing device **1800** is contained within the housing **1200** and is coupled between the keypad **1400** and the display **1600**. The processing device **1800** controls the operation of the display **1600**, as well as the overall operation of the mobile device **1000**, in response to actuation of keys on the keypad **1400**.

[0041] The housing **1200** may be elongated vertically, or may take on other sizes and shapes (including clamshell housing structures). The keypad may include a mode selection key, or other hardware or software for switching between text entry and telephony entry.

[0042] In addition to the processing device **1800**, other parts of the mobile device **1000** are shown schematically in FIG. 17. These include a communications subsystem **1001**; a short-range communications subsystem **1020**; the keypad **1400** and the display **1600**, along with other input/output devices **1060**, **1080**, **1100** and **1120**; as well as memory devices **1160**, **1180** and various other device subsystems **1201**. The mobile device **1000** may comprise a two-way RF communications device having data and, optionally, voice communications capabilities. In addition, the mobile device **1000** may have the capability to communicate with other computer systems via the Internet.

[0043] Operating system software executed by the processing device **1800** is stored in a persistent store, such as the flash memory **1160**, but may be stored in other types of memory devices, such as a read only memory (ROM) or similar storage element. In addition, system software, specific device applications, or parts thereof, may be temporarily loaded into a volatile store,

such as the random access memory (RAM) **1180**. Communications signals received by the mobile device may also be stored in the RAM **1180**.

[0044] The processing device **1800**, in addition to its operating system functions, enables execution of software applications **1300A-1300N** on the device **1000**. A predetermined set of applications that control basic device operations, such as data and voice communications **1300A** and **1300B**, may be installed on the device **1000** during manufacture. In addition, a personal information manager (PIM) application may be installed during manufacture. The PIM may be capable of organizing and managing data items, such as e-mail, calendar events, voice mails, appointments, and task items. The PIM application may also be capable of sending and receiving data items via a wireless network **1401**. The PIM data items may be seamlessly integrated, synchronized and updated via the wireless network **1401** with corresponding data items stored or associated with a host computer system.

[0045] Communication functions, including data and voice communications, are performed through the communications subsystem **1001**, and possibly through the short-range communications subsystem. The communications subsystem **1001** includes a receiver **1500**, a transmitter **1520**, and one or more antennas **1540** and **1560**. In addition, the communications subsystem **1001** also includes a processing module, such as a digital signal processor (DSP) **1580**, and local oscillators (LOs) **1601**. The specific design and implementation of the communications subsystem **1001** is dependent upon the communications network in which the mobile device **1000** is intended to operate. For example, a mobile device **1000** may

41105-CA-PAT

include a communications subsystem **1001** designed to operate with the Mobitex™, Data TAC™ or General Packet Radio Service (GPRS) mobile data communications networks, and also designed to operate with any of a variety of voice communications networks, such as AMPS, TDMA, CDMA, WCDMA, PCS, GSM, EDGE, etc. Other types of data and voice networks, both separate and integrated, may also be utilized with the mobile device **1000**. The mobile device **1000** may also be compliant with other communications standards such as 3GSM, 3GPP, UMTS, 4G, etc.

[0046] Network access requirements vary depending upon the type of communication system. For example, in the Mobitex and DataTAC networks, mobile devices are registered on the network using a unique personal identification number or PIN associated with each device. In GPRS networks, however, network access is associated with a subscriber or user of a device. A GPRS device therefore typically involves use of a subscriber identity module, commonly referred to as a SIM card, in order to operate on a GPRS network.

[0047] When required network registration or activation procedures have been completed, the mobile device **1000** may send and receive communications signals over the communication network **1401**. Signals received from the communications network **1401** by the antenna **1540** are routed to the receiver **1500**, which provides for signal amplification, frequency down conversion, filtering, channel selection, etc., and may also provide analog to digital conversion. Analog-to-digital conversion of the received signal allows the DSP **1580** to perform more complex communications functions, such as demodulation and decoding. In a similar manner, signals to be transmitted to the network **1401** are processed (e.g. modulated and encoded) by the DSP **1580** and

are then provided to the transmitter **1520** for digital to analog conversion, frequency up conversion, filtering, amplification and transmission to the communication network **1401** (or networks) via the antenna **1560**.

[0048] In addition to processing communications signals, the DSP **1580** provides for control of the receiver **1500** and the transmitter **1520**. For example, gains applied to communications signals in the receiver **1500** and transmitter **1520** may be adaptively controlled through automatic gain control algorithms implemented in the DSP **1580**.

[0049] In a data communications mode, a received signal, such as a text message or web page download, is processed by the communications subsystem **1001** and is input to the processing device **1800**. The received signal is then further processed by the processing device **1800** for an output to the display **1600**, or alternatively to some other auxiliary I/O device **1060**. A device may also be used to compose data items, such as e-mail messages, using the keypad **1400** and/or some other auxiliary I/O device **1060**, such as a touchpad, a rocker switch, a thumb-wheel, or some other type of input device. The composed data items may then be transmitted over the communications network **1401** via the communications subsystem **1001**.

[0050] In a voice communications mode, overall operation of the device is substantially similar to the data communications mode, except that received signals are output to a speaker **1100**, and signals for transmission are generated by a microphone **1120**. Alternative voice or audio I/O subsystems, such as a voice message recording subsystem, may also be implemented on the device **1000**. In addition, the display **1600** may also be utilized in voice communications mode, for example to display the

41105-CA-PAT

identity of a calling party, the duration of a voice call, or other voice call related information.

[0051] The short-range communications subsystem enables communication between the mobile device **1000** and other proximate systems or devices, which need not necessarily be similar devices. For example, the short-range communications subsystem may include an infrared device and associated circuits and components, a Bluetooth™ communications module to provide for communication with similarly-enabled systems and devices, or a near field communications (NFC) sensor for communicating with a NFC device or NFC tag via NFC communications.

[0052] Many modifications and other embodiments of the present disclosure will come to the mind of one skilled in the art having the benefit of the teachings presented in the foregoing descriptions and the associated drawings. Therefore, it is understood that the present disclosure is not to be limited to the specific embodiments disclosed, and that modifications and embodiments are intended to be included within the scope of the appended claims.

THAT WHICH IS CLAIMED IS:

1. A mobile wireless communications device comprising:

a housing;

a circuit board carried by said housing;

wireless communications circuitry carried by said circuit board; and

an antenna assembly carried by said housing and coupled to said wireless communications circuitry, said antenna assembly comprising

an electrically conductive base having a rectangular shape with opposing first and second ends and opposing first and second sides extending between the first and second ends,

said electrically conductive base having an elongate slot therein extending within a medial portion thereof and contained within the opposing first and second ends and the opposing first and second sides, and

an electrically conductive feed arm extending outwardly from the first side of said electrically conductive base adjacent the first end thereof,

said electrically conductive feed arm having a distal end with at least one antenna feed defined thereon.

41105-CA-PAT

2. The mobile wireless communications device of Claim 1 wherein said antenna assembly comprises a flexible substrate mounting said electrically conductive base and said electrically conductive feed arm.

3. The mobile wireless communications device of Claim 2 wherein said flexible substrate comprises:

a planar base mounting portion spaced from said circuit board and mounting said electrically conductive base; and

an arm mounting portion extending downwardly from said planar base mounting portion and mounting said electrically conductive feed arm.

4. The mobile wireless communications device of Claim 1 wherein the elongate slot is longitudinally offset from the first end and toward the second end of said electrically conductive base.

5. The mobile wireless communications device of Claim 1 wherein the elongate slot is centered between the first and second sides of said electrically conductive base.

6. The mobile wireless communications device of Claim 1 wherein the elongate slot has a rectangular shape.

7. The mobile wireless communications device of Claim 1 wherein the elongate slot has a width less than a third of a width of said electrically conductive base.

41105-CA-PAT

8. The mobile wireless communications device of Claim 1 wherein the elongate slot has a length greater than half a length of said electrically conductive base.

9. The mobile wireless communications device of Claim 1 wherein the elongate slot has a length greater than a corresponding length of said electrically conductive feed arm.

10. The mobile wireless communications device of Claim 1 wherein the at least one antenna feed comprises first and second antenna feeds; and wherein said electrically conductive feed arm has a slot therein extending through a medial portion between said first and second antenna feeds.

11. The mobile wireless communications device according to Claim 1 wherein said antenna assembly is operable in a plurality of frequency bands.

12. An antenna assembly for a mobile wireless communications device comprising a housing, a circuit board carried by said housing, and wireless communications circuitry carried by said circuit board, the antenna assembly to be coupled to the wireless communications circuitry and comprising:

an electrically conductive base having a rectangular shape with opposing first and second ends and opposing first and second sides extending between the first and second ends;

said electrically conductive base having an elongate slot therein extending within a medial portion thereof and contained within the opposing first and second ends and the opposing first and second sides; and

41105-CA-PAT

an electrically conductive feed arm extending outwardly from the first side of said electrically conductive base adjacent the first end thereof;

said electrically conductive feed arm having a distal end with at least one antenna feed defined thereon.

13. The antenna assembly of Claim 12 further comprising a flexible substrate mounting said electrically conductive base and said electrically conductive feed arm.

14. The antenna assembly of Claim 13 wherein said flexible substrate comprises:

a planar base mounting portion spaced from the circuit board and mounting said electrically conductive base; and

an arm mounting portion extending downwardly from said planar base mounting portion and mounting said electrically conductive feed arm.

15. The antenna assembly of Claim 12 wherein the elongate slot is centered between the first and second sides of said electrically conductive base.

16. The antenna assembly of Claim 12 wherein the elongate slot has a rectangular shape.

17. The antenna assembly of Claim 12 wherein the elongate slot has a width less than a third of a width of said electrically conductive base.

41105-CA-PAT

18. A method of making an antenna assembly for a mobile wireless communications device comprising a housing, a circuit board carried by the housing, and wireless communications circuitry carried by the circuit board, the method comprising:

forming an electrically conductive base having a rectangular shape with opposing first and second ends and opposing first and second sides extending between the first and second ends, the electrically conductive base being formed to have an elongate slot therein extending within a medial portion thereof and contained within the opposing first and second ends and the opposing first and second sides; and

forming an electrically conductive feed arm extending outwardly from the first side of the electrically conductive base adjacent the first end thereof, the electrically conductive feed arm being formed to have a distal end with at least one antenna feed defined thereon.

19. The method of Claim 18 wherein the elongate slot is formed to be longitudinally offset from the first end and toward the second end of the electrically conductive base.

20. The method of Claim 18 wherein the elongate slot is formed to be centered between the first and second sides of the electrically conductive base.

21. The method of Claim 18 wherein the elongate slot is formed to have a rectangular shape.

41105-CA-PAT

22. The method of Claim 18 wherein the elongate slot is formed to have a width less than a third of a width of the electrically conductive base.

23. The method of Claim 18 wherein the elongate slot is formed to have a length greater than half a length of the electrically conductive base.

24. The method of Claim 18 wherein the elongate slot is formed to have a length greater than a corresponding length of the electrically conductive feed arm.

1/8

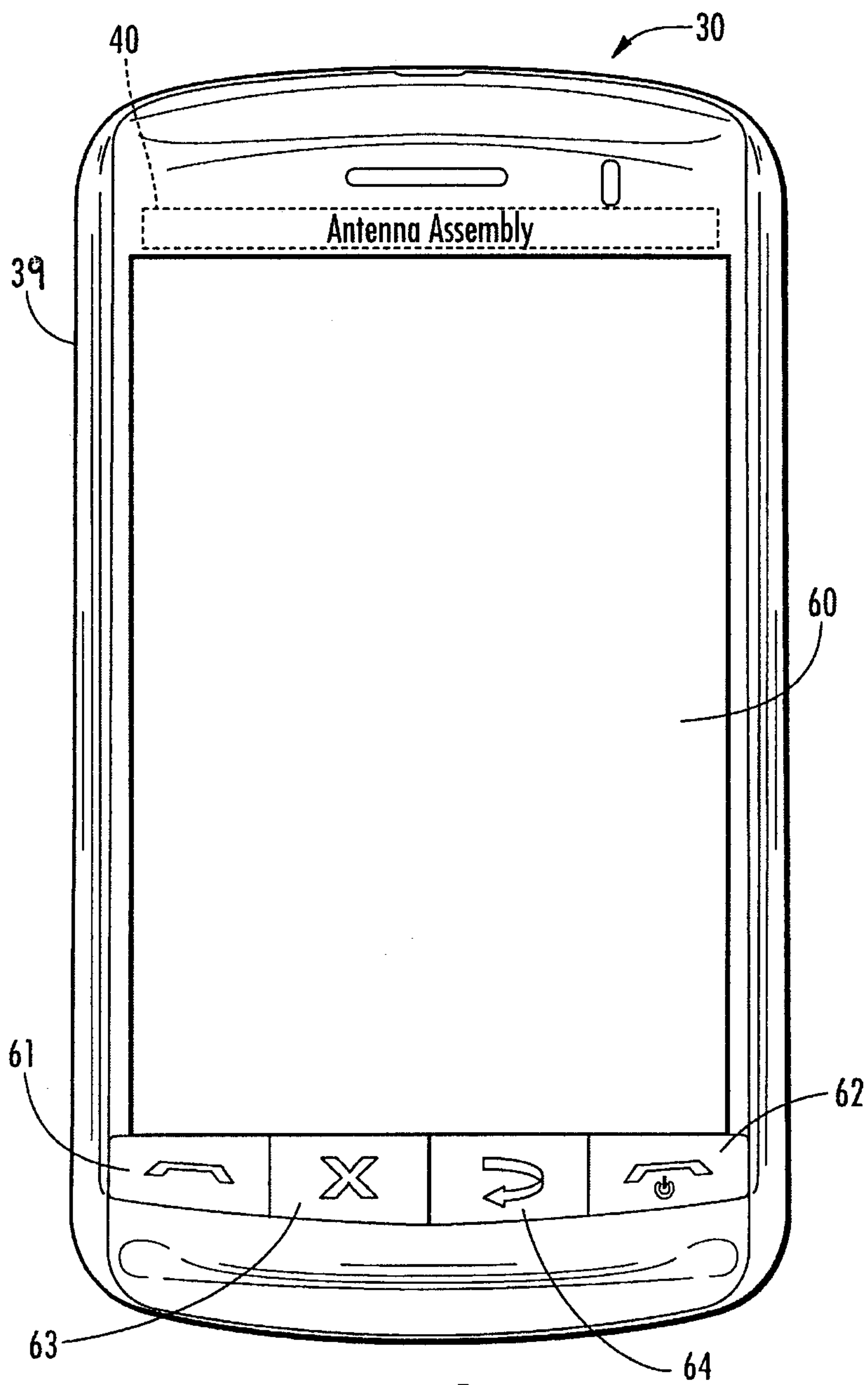

FIG. 1

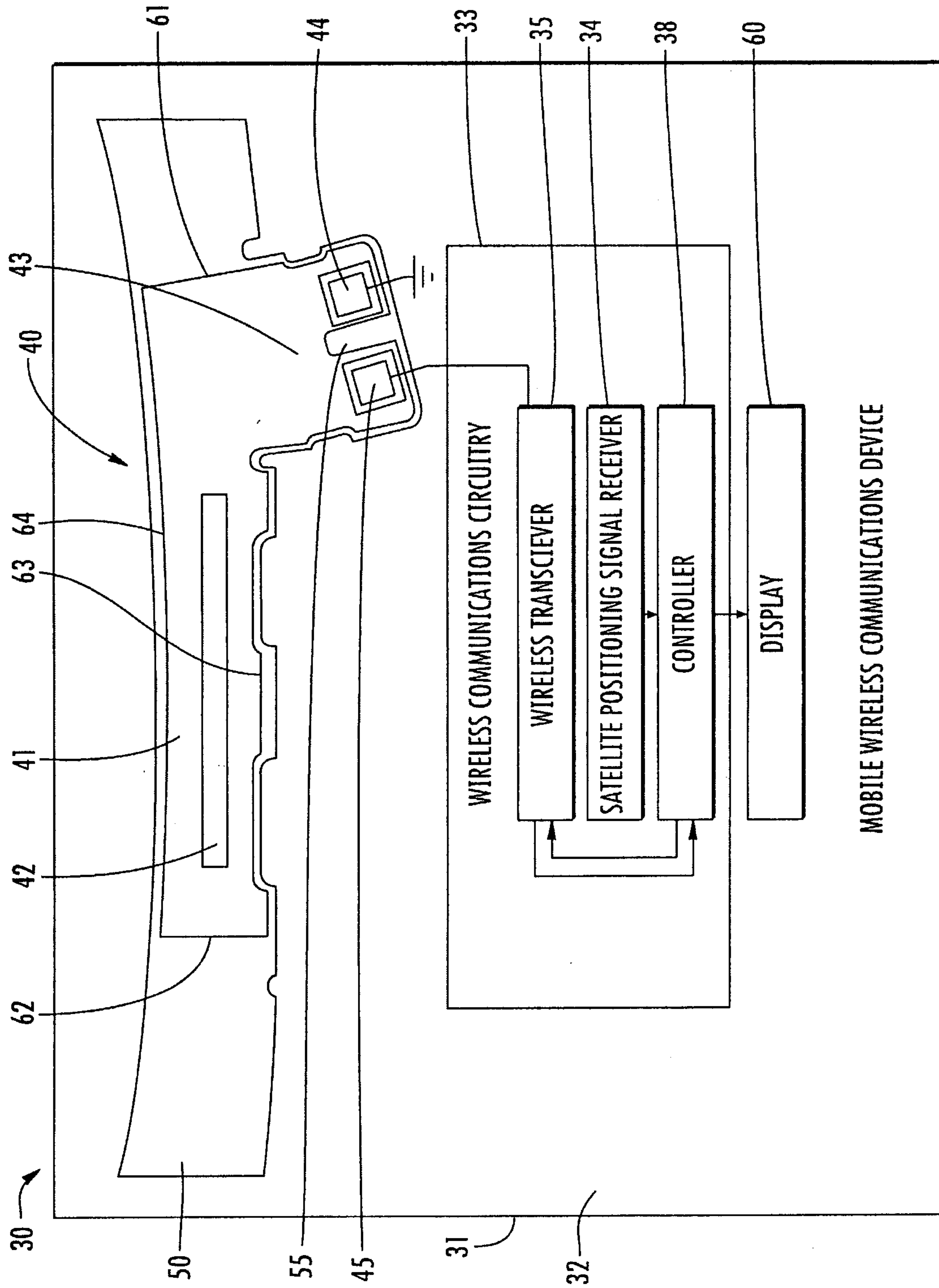

FIG. 2

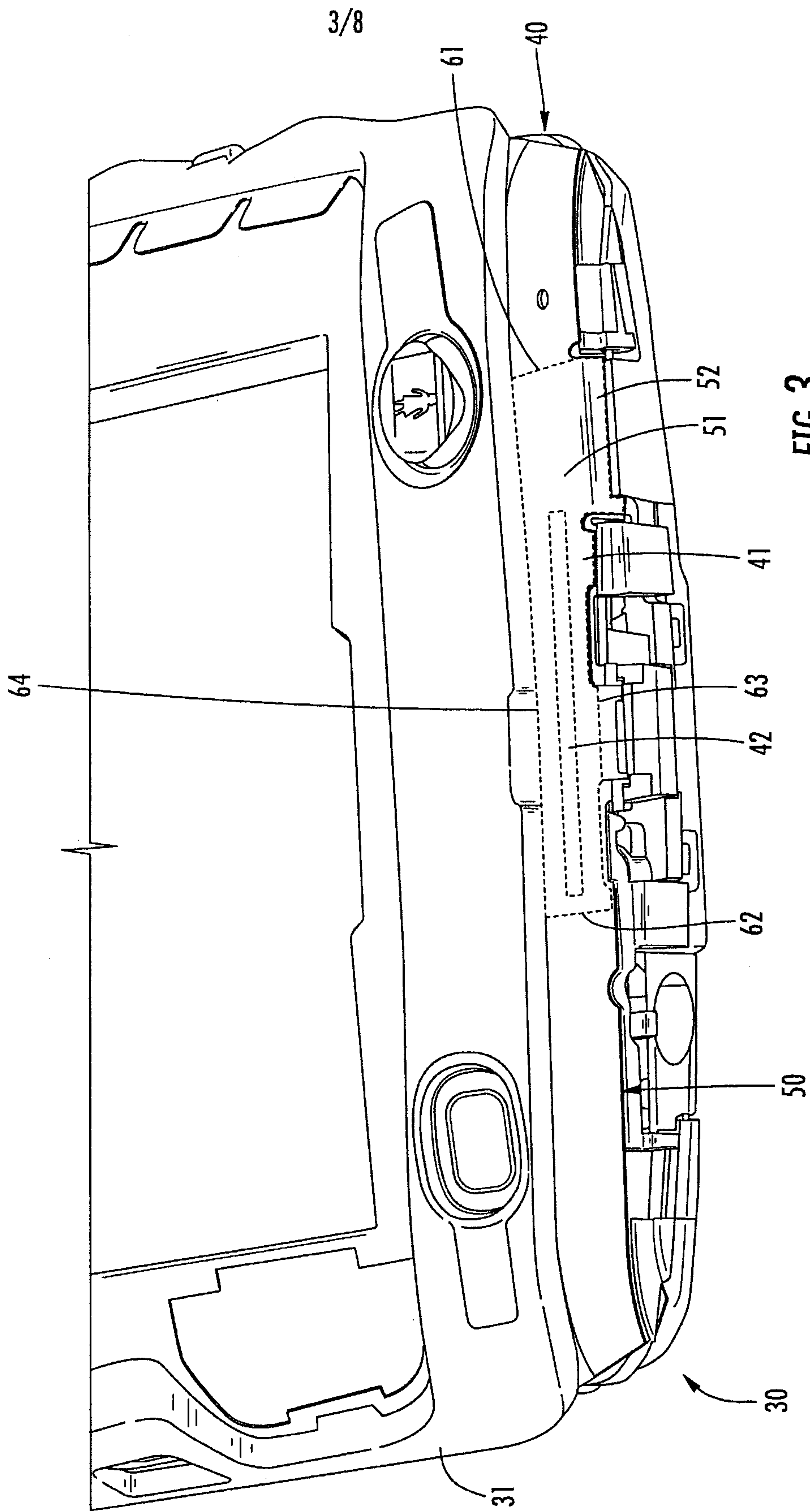

FIG. 3

4/8

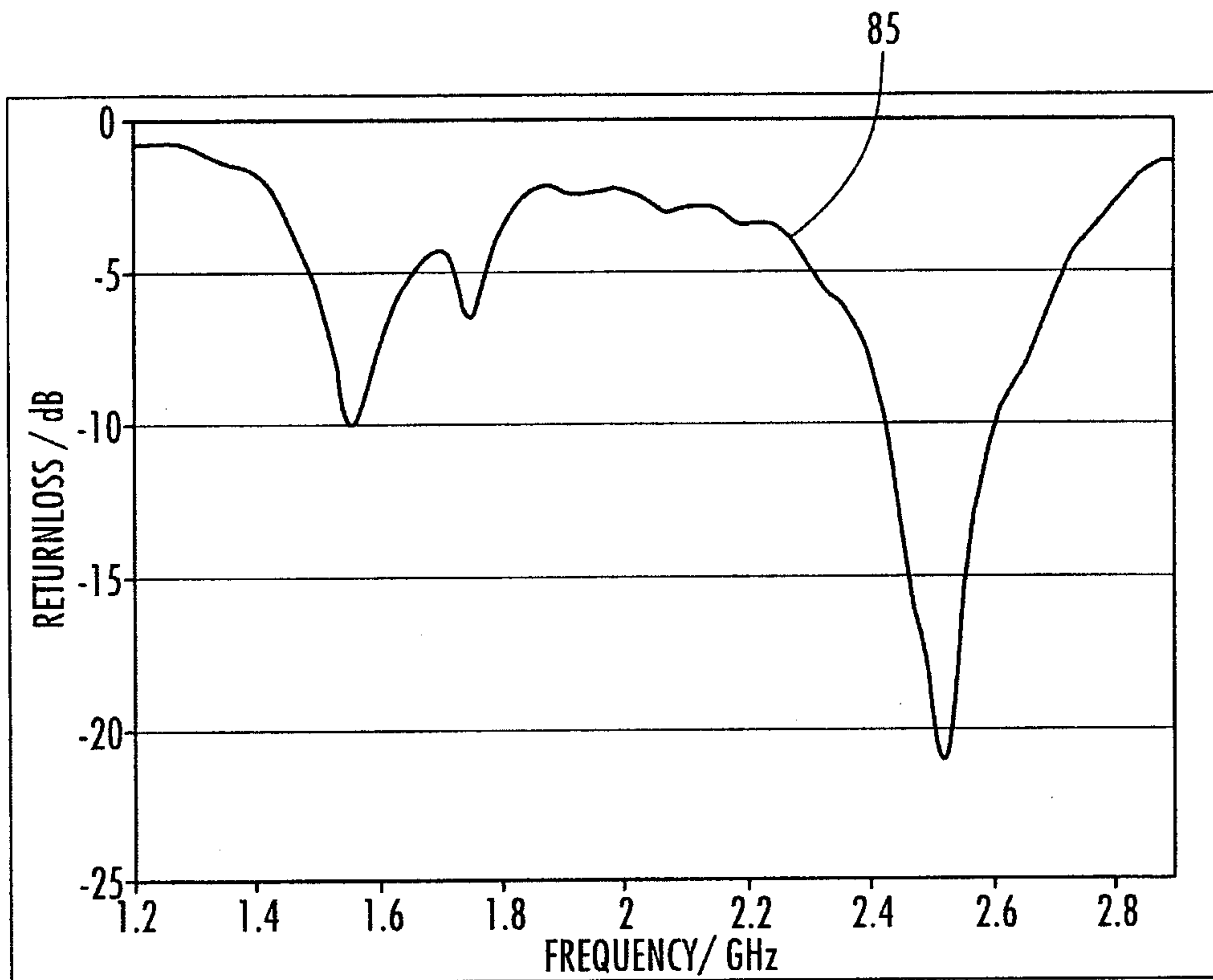

FIG. 4

5/8

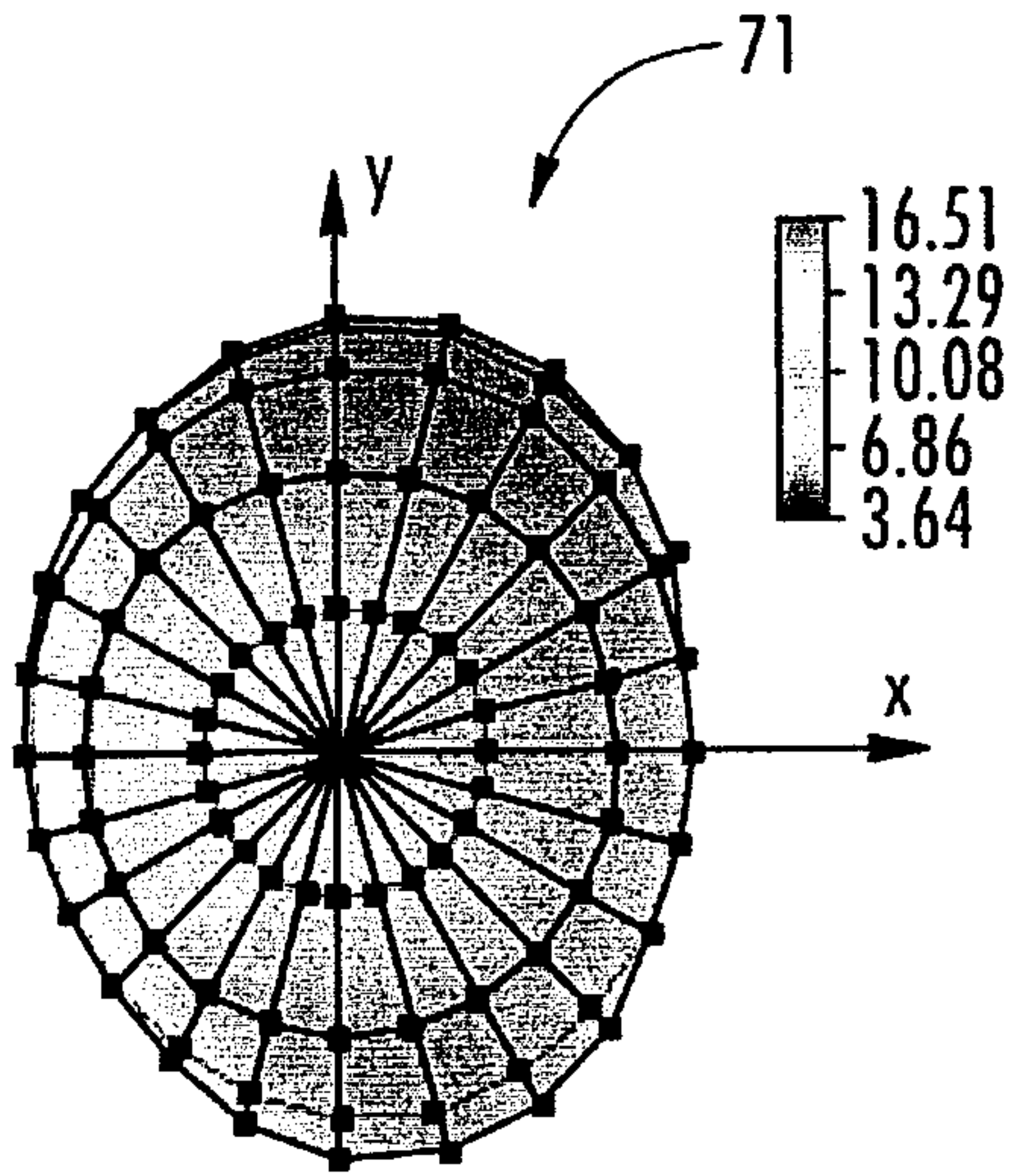

FIG. 5

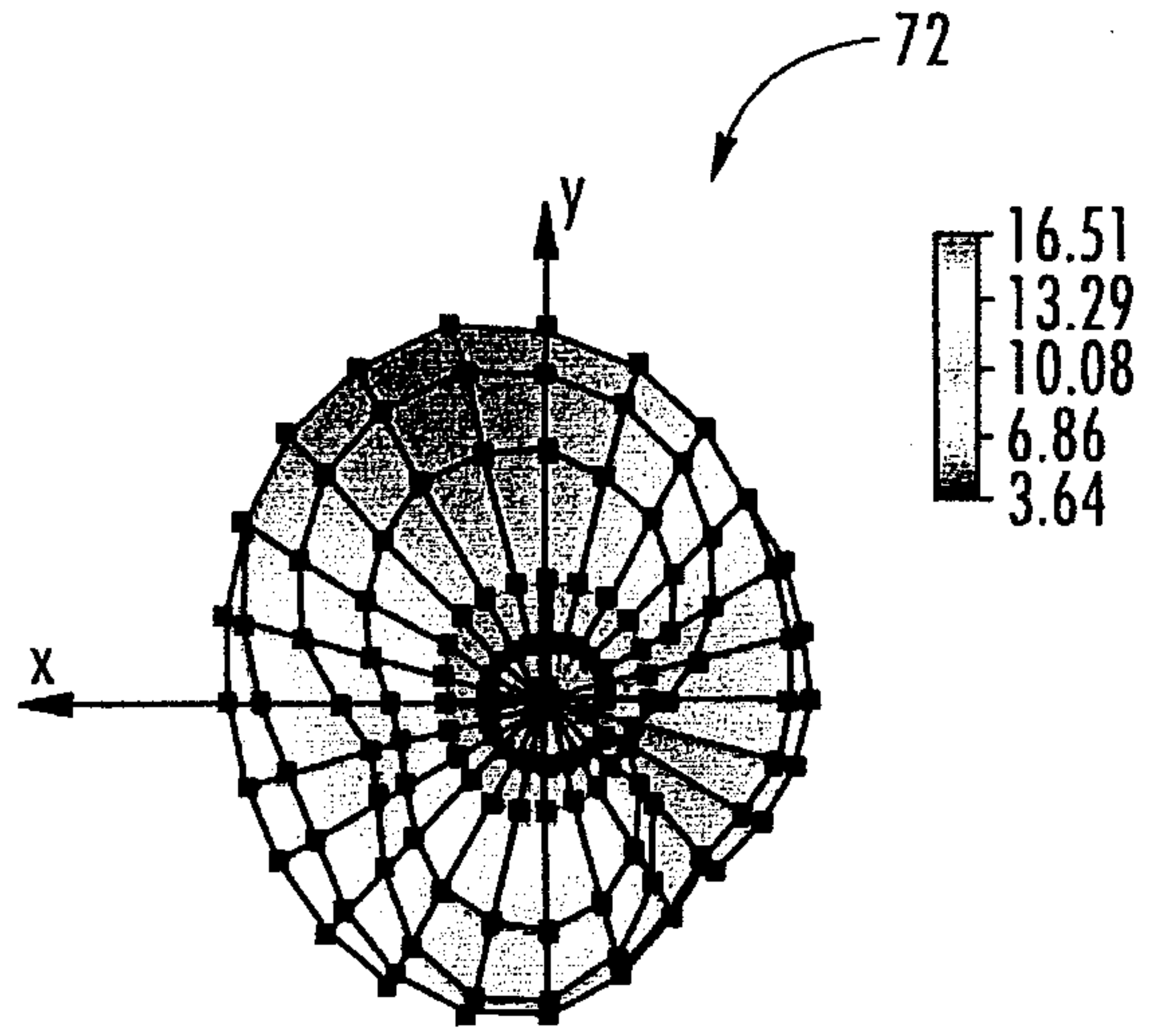

FIG. 6

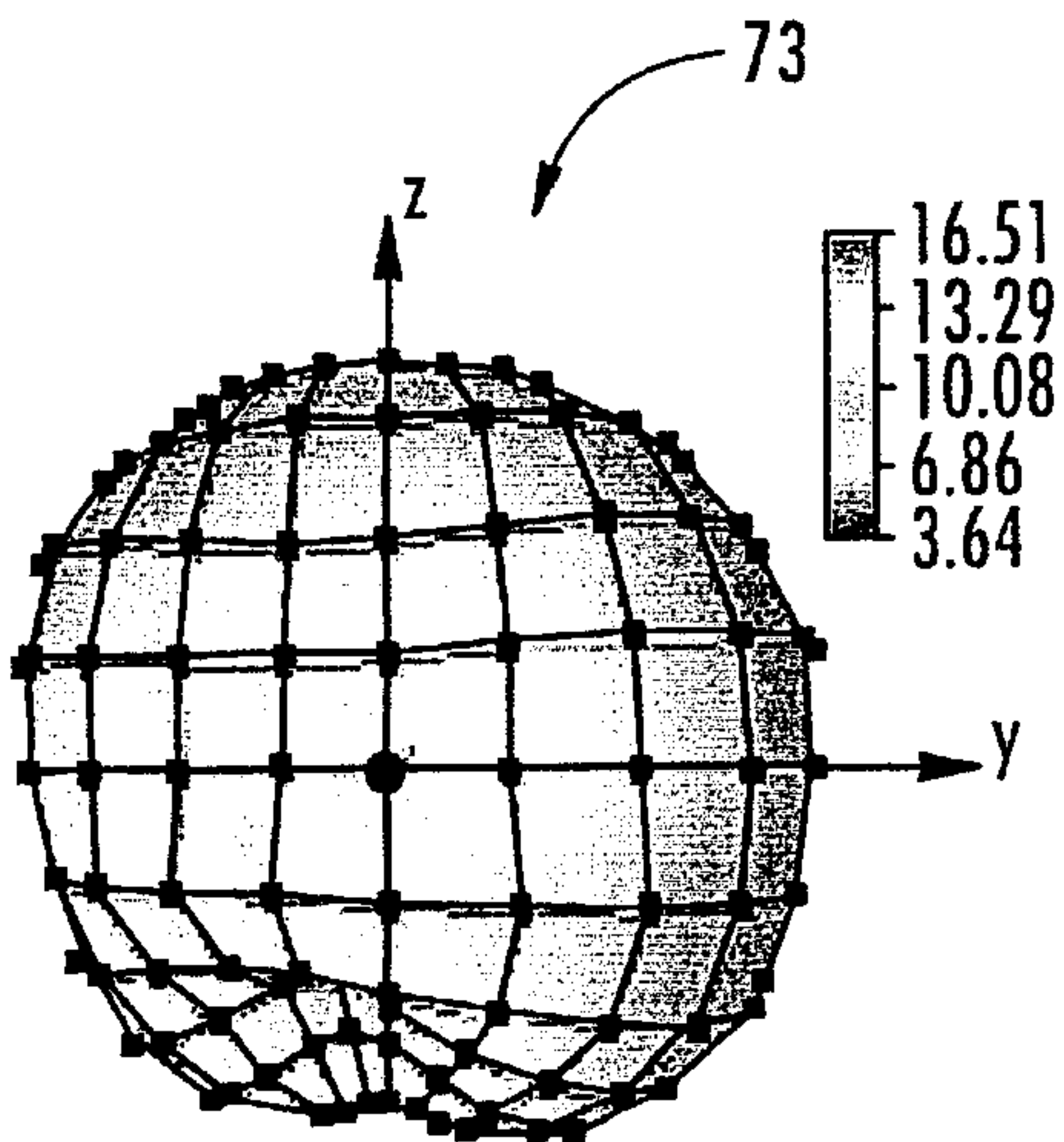

FIG. 7

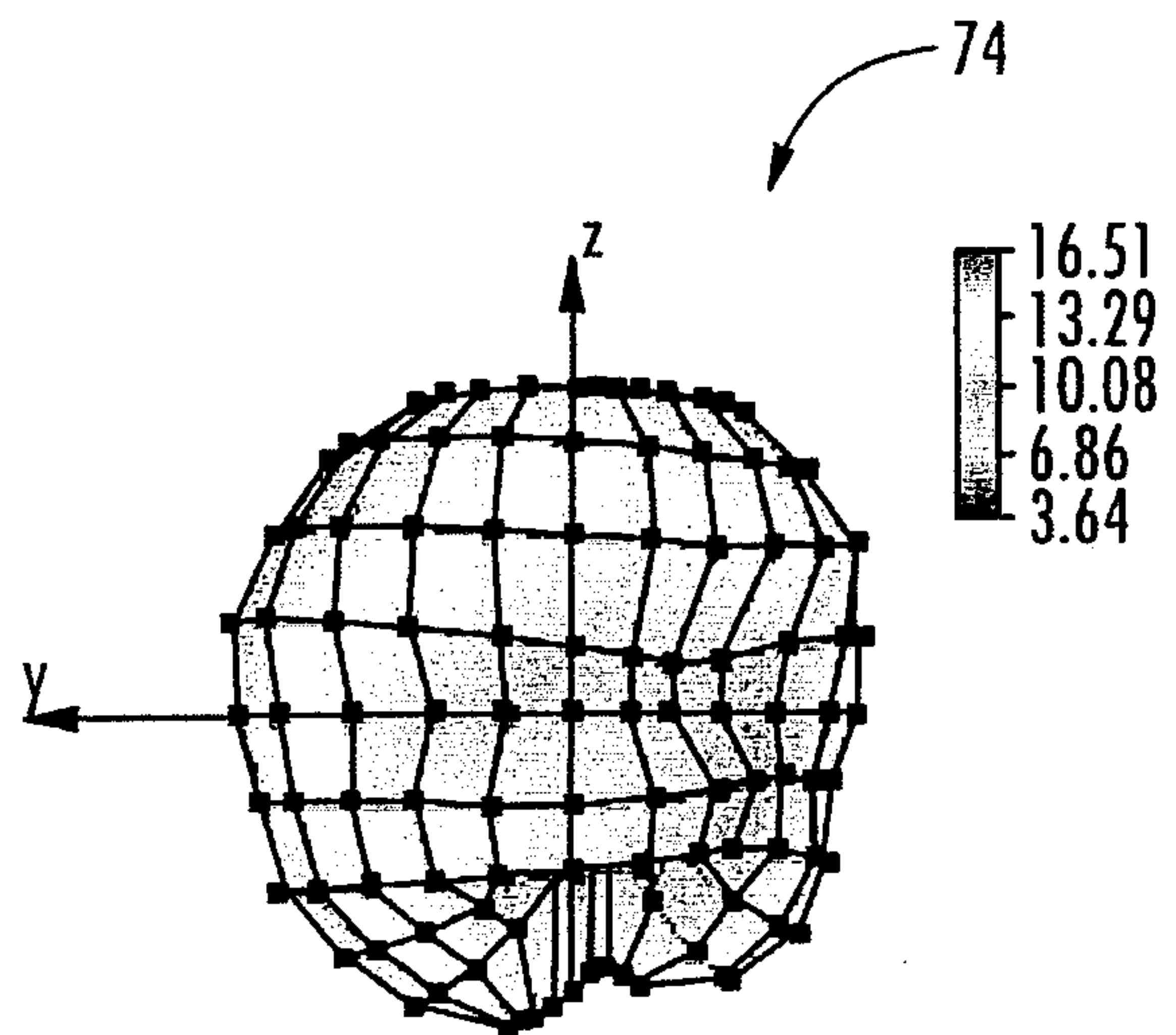
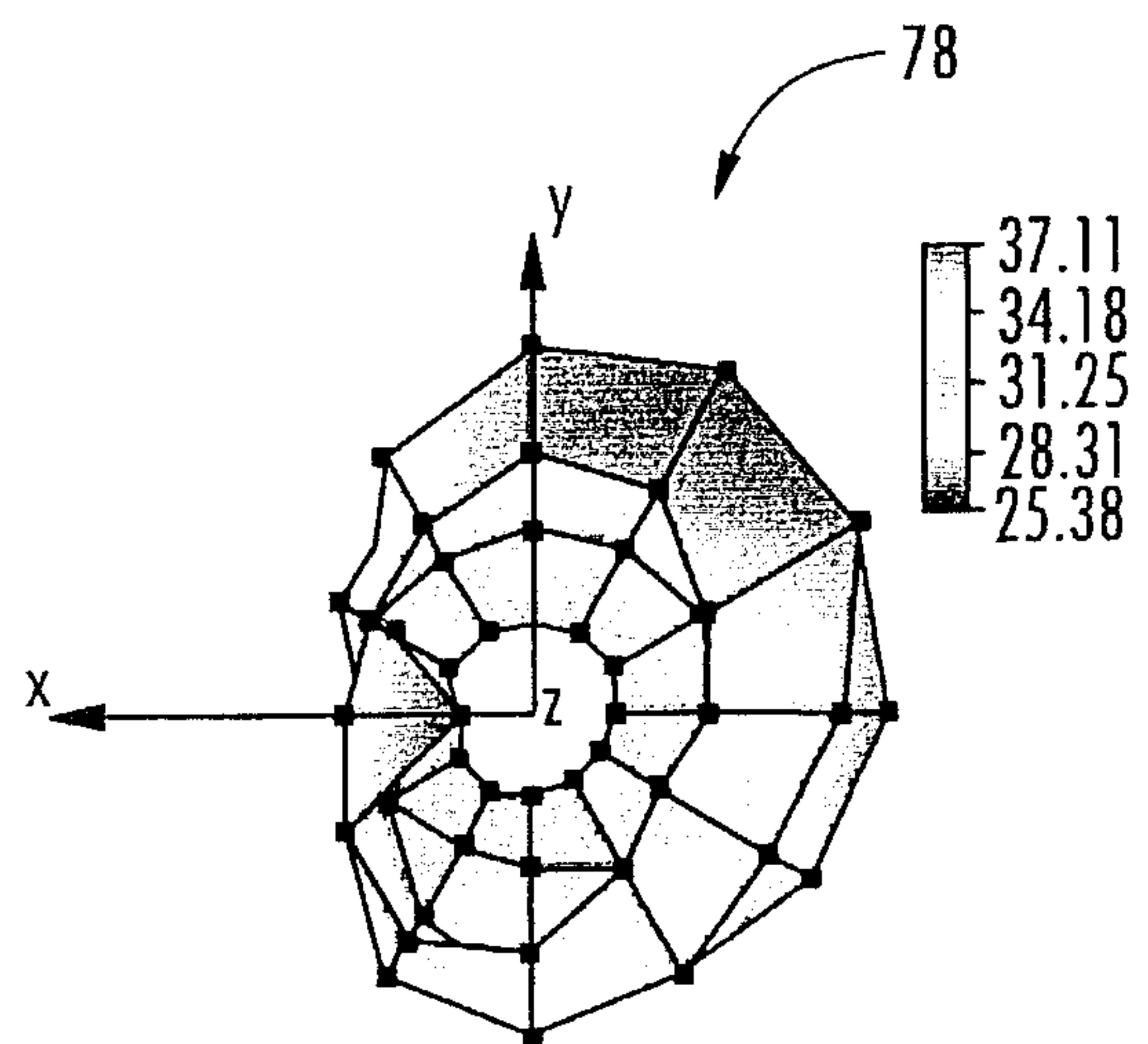
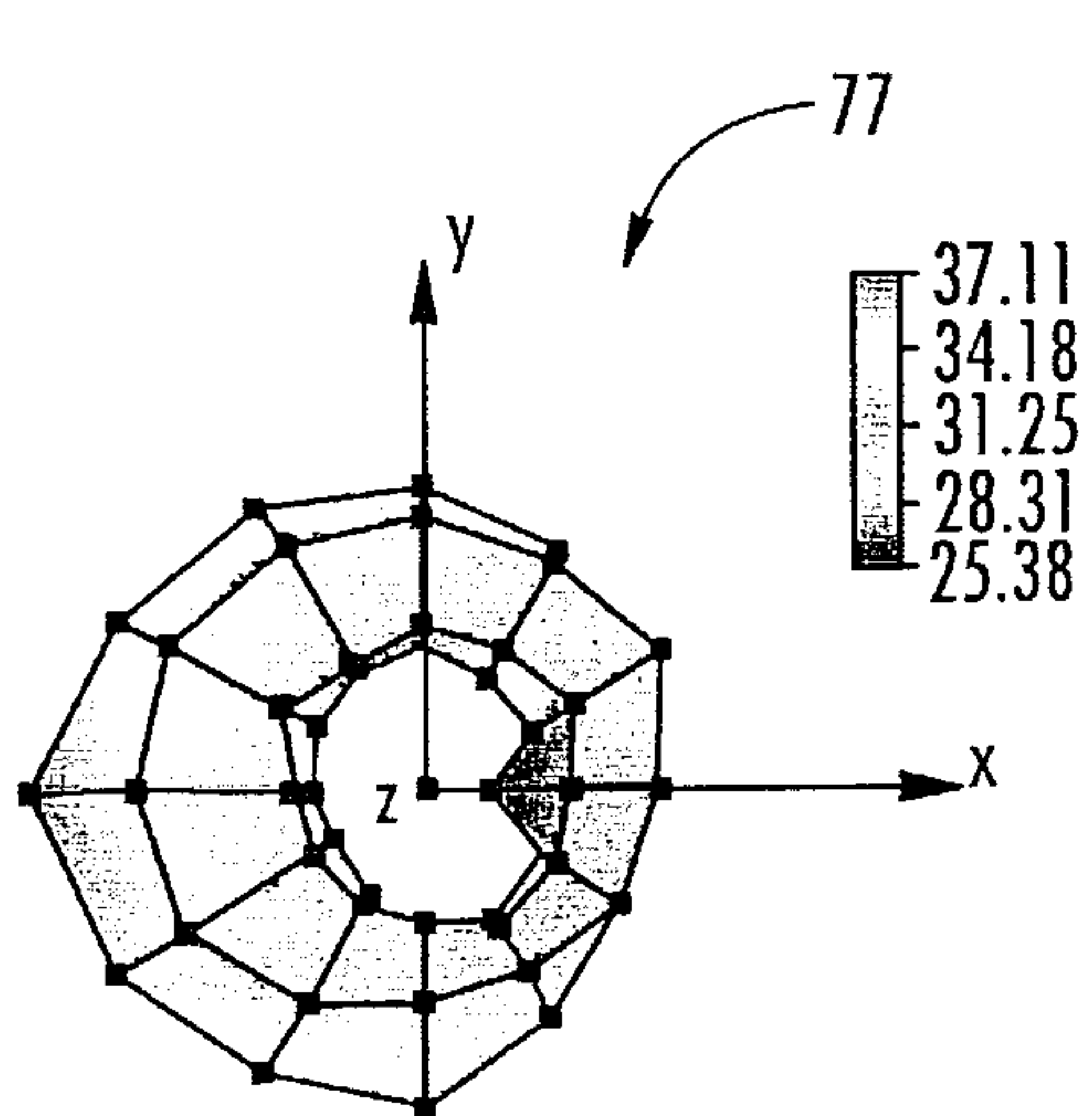
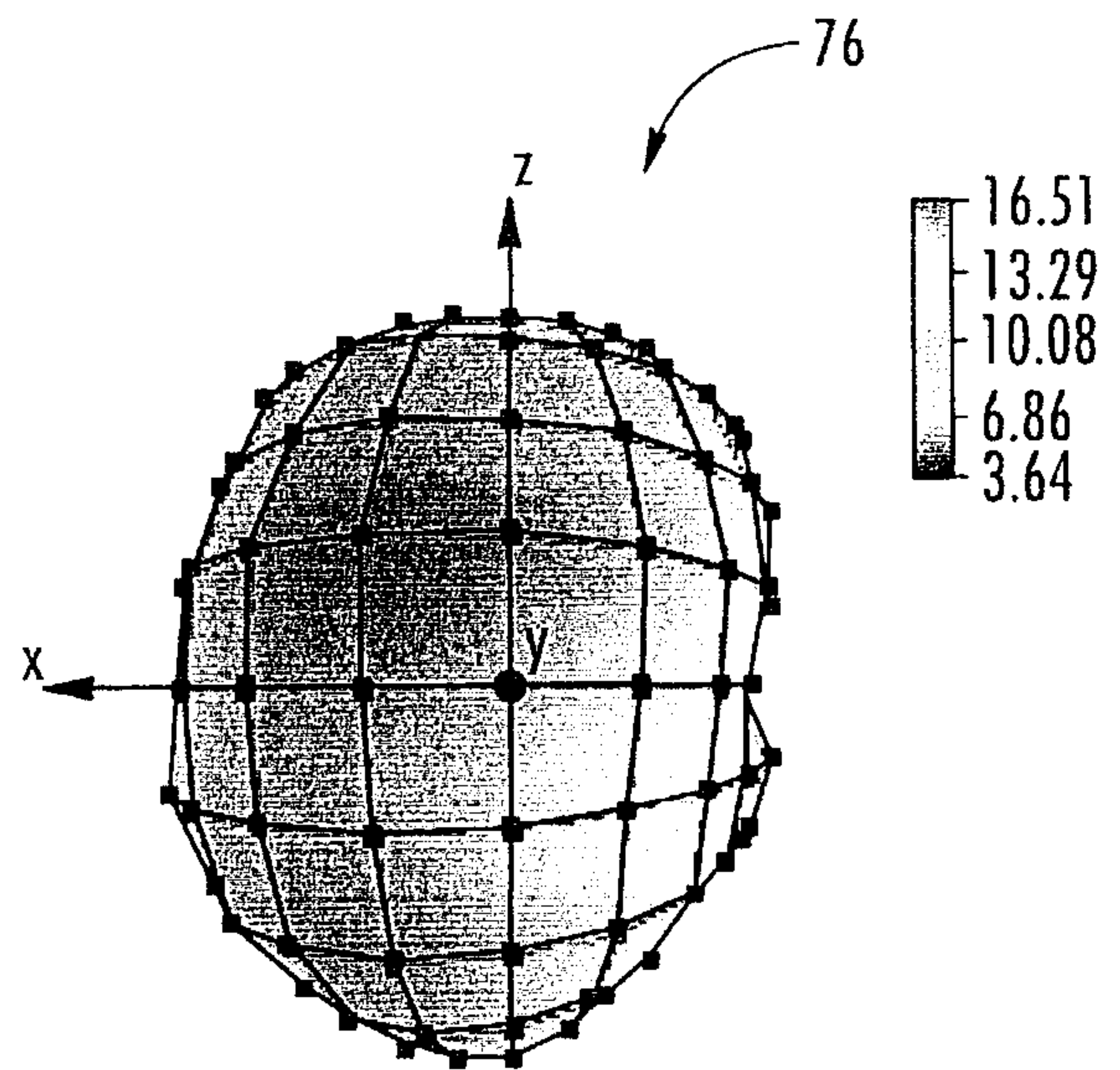
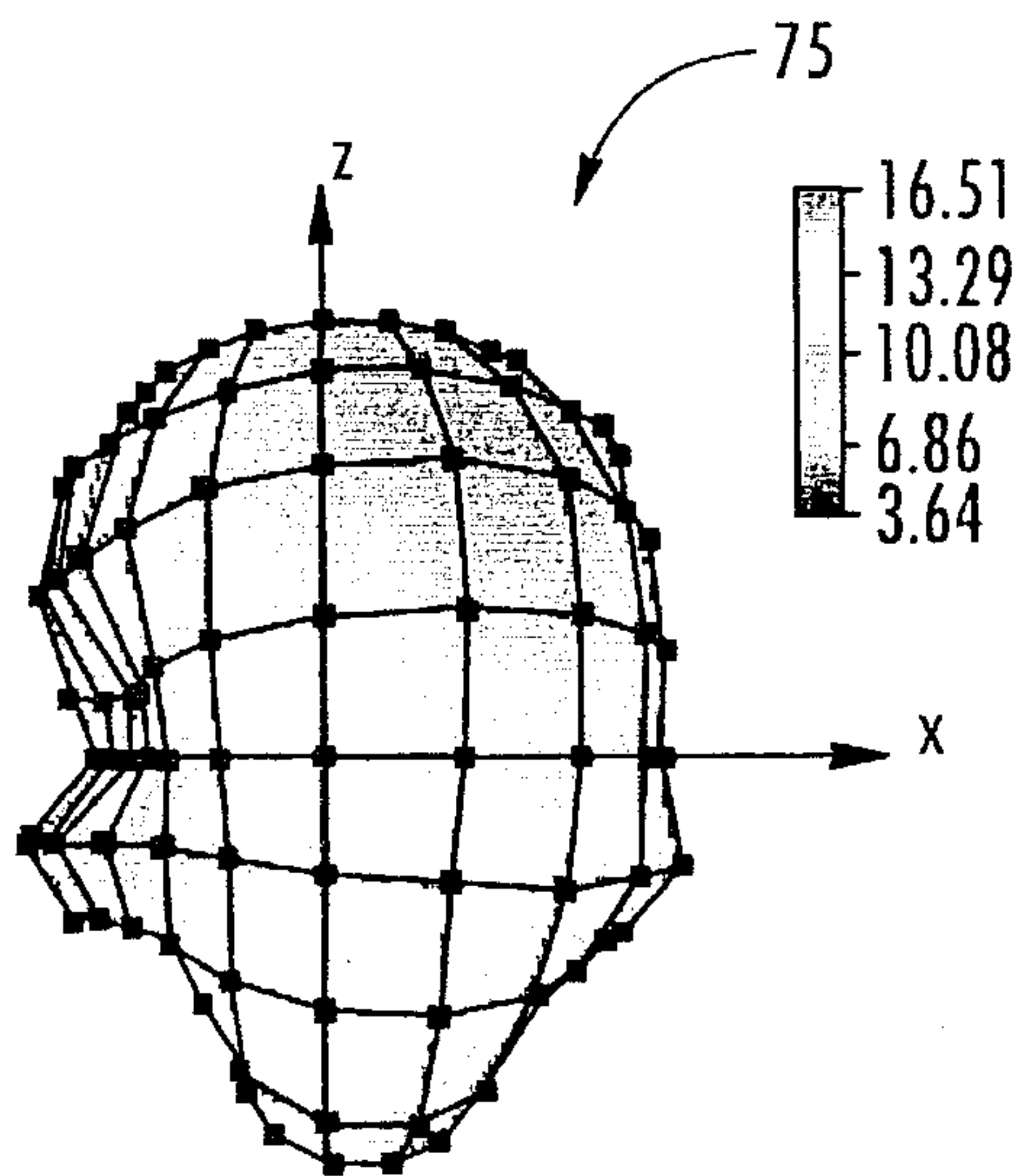

FIG. 8

6/8



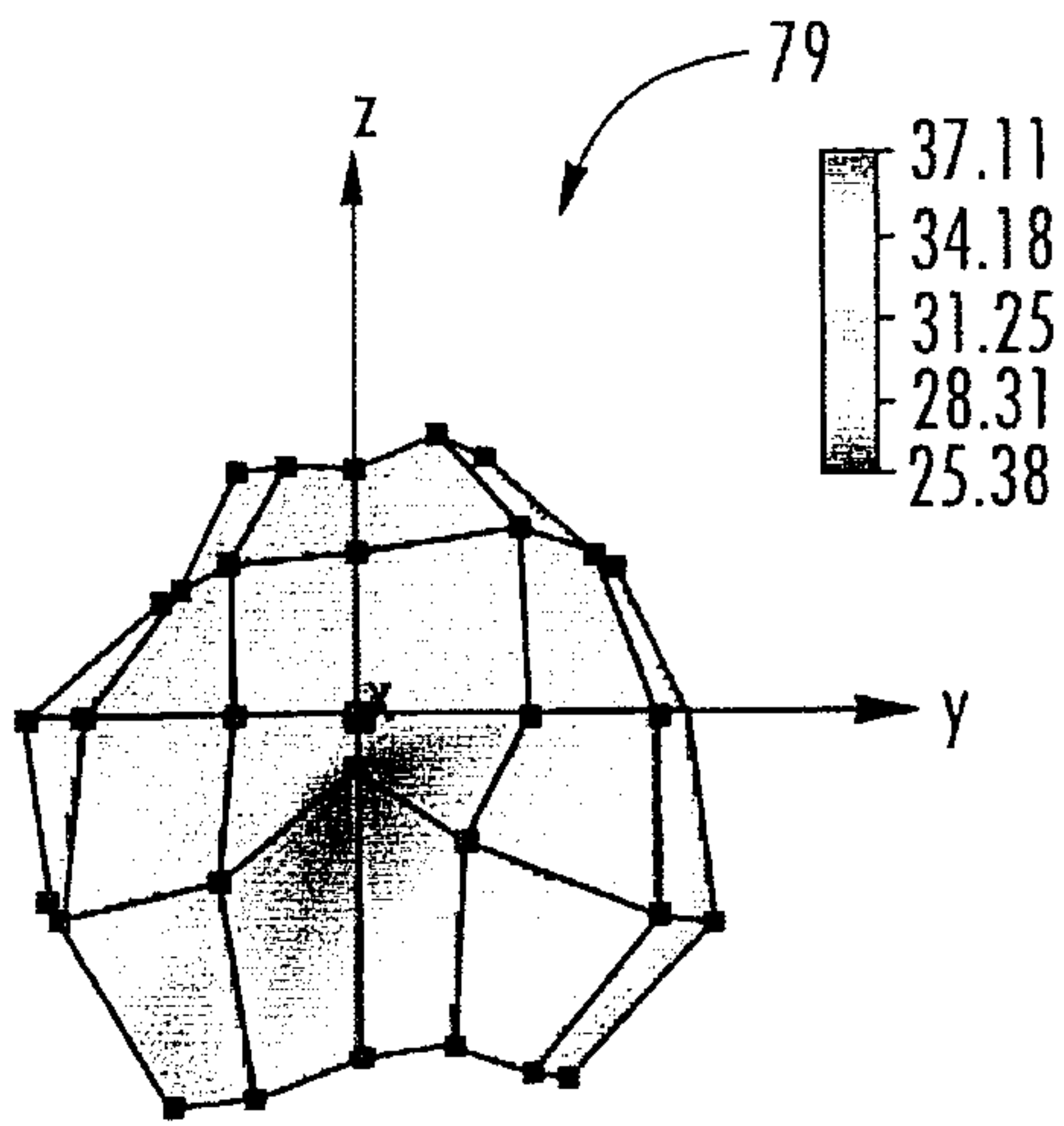

FIG. 13

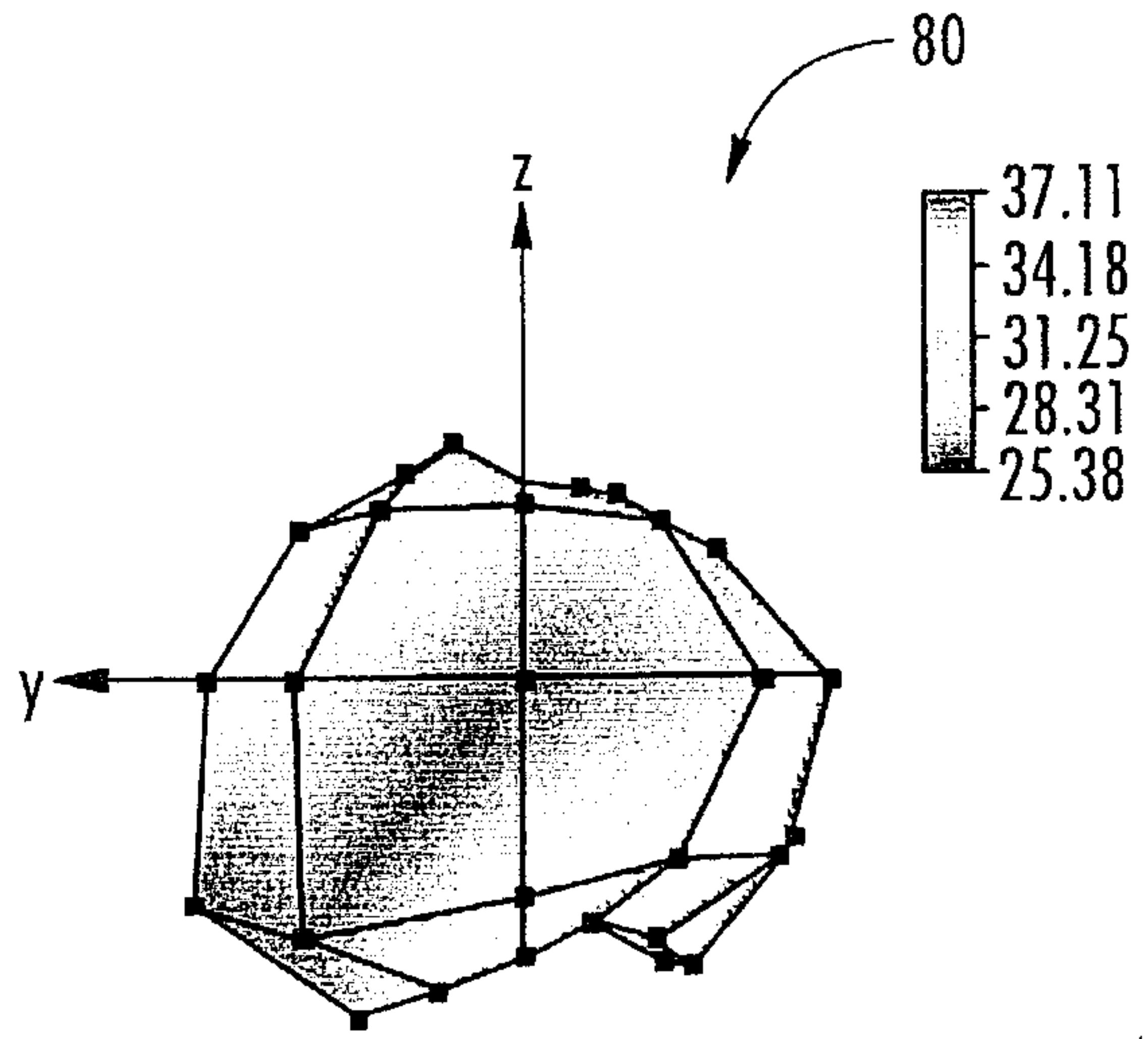

FIG. 14

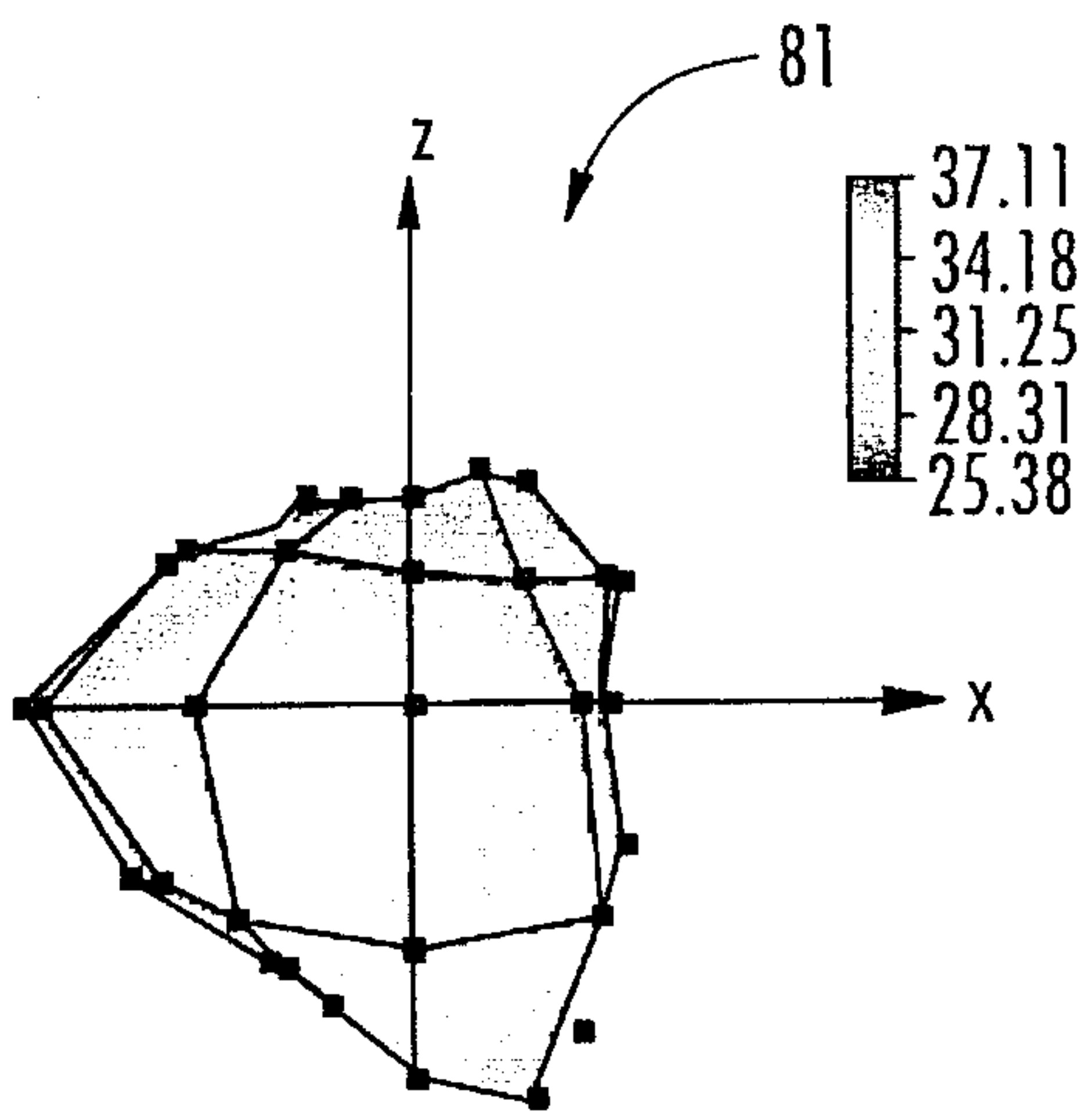

FIG. 15

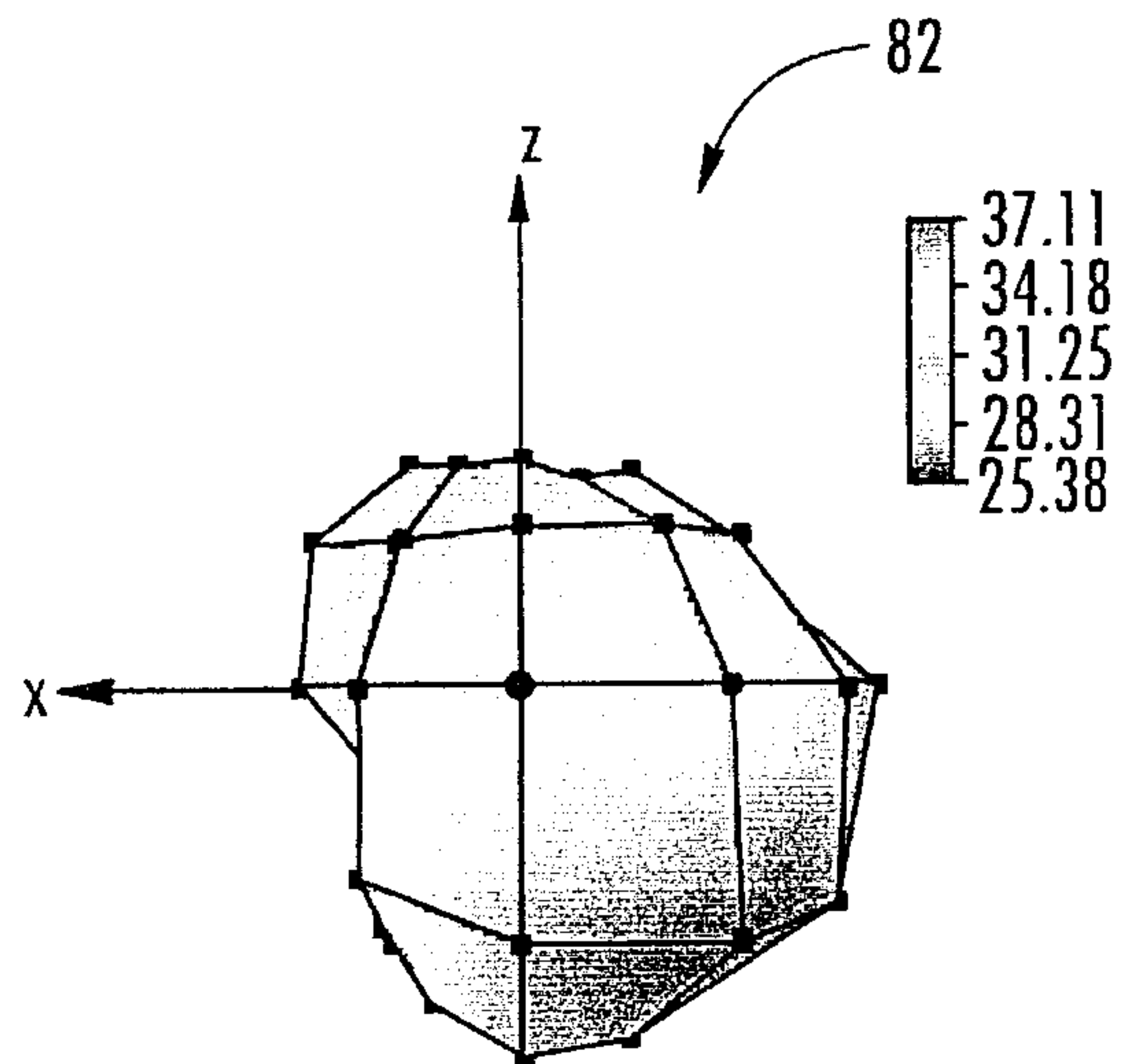

FIG. 16

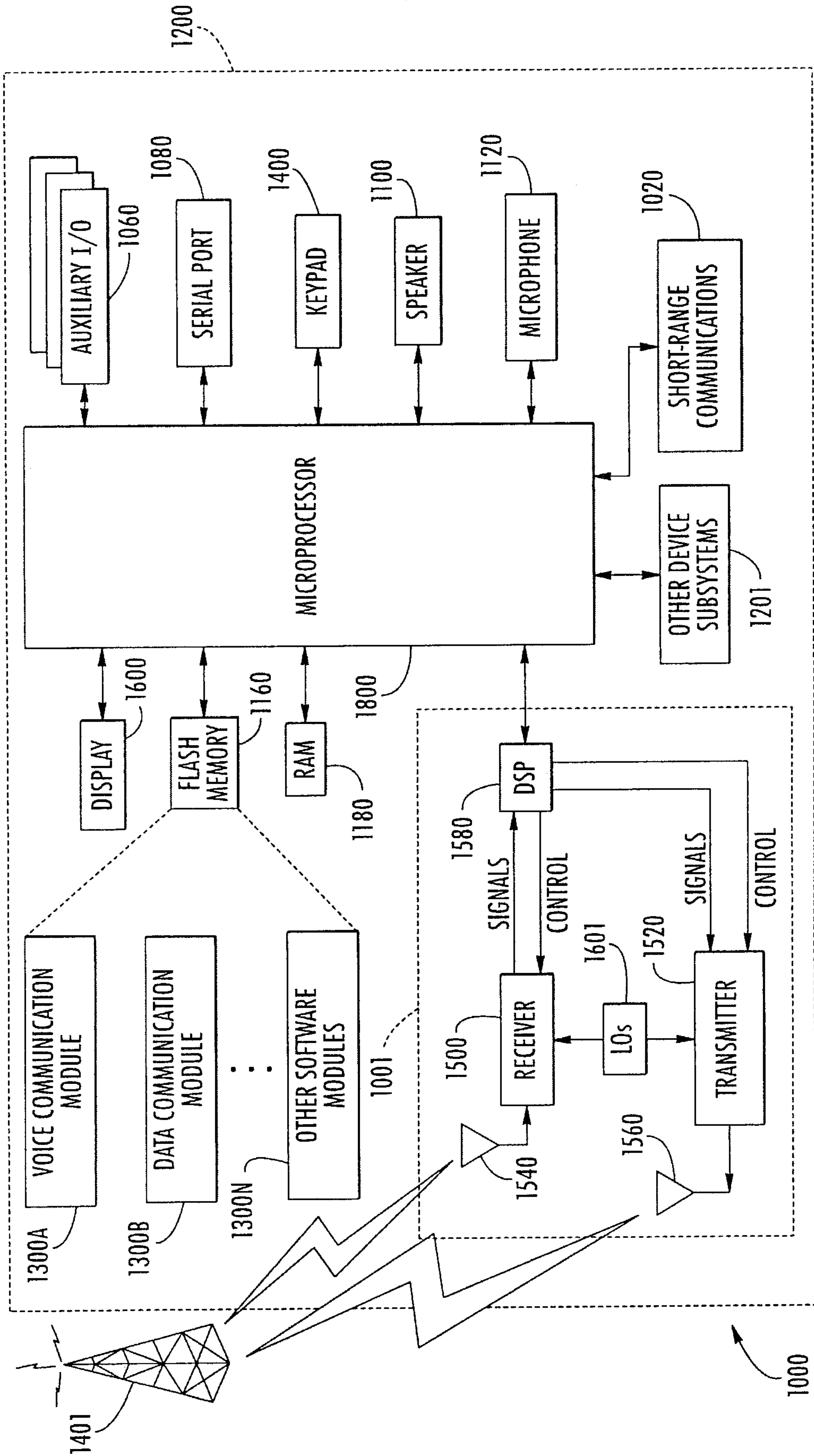
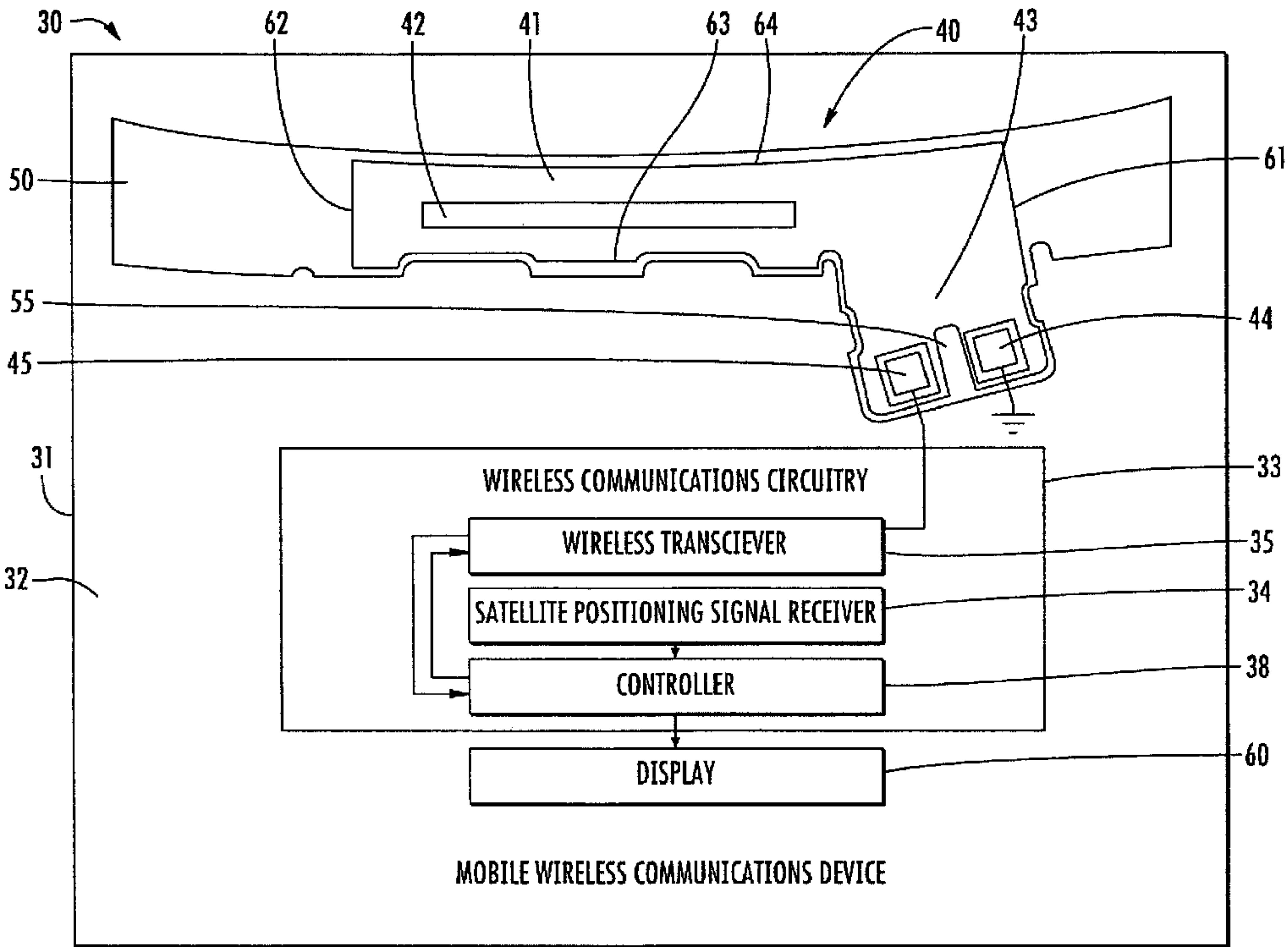

FIG. 17



MOBILE WIRELESS COMMUNICATIONS DEVICE