



US00D719263S

(12) **United States Design Patent**
Shibata et al.

(10) **Patent No.:** **US D719,263 S**

(45) **Date of Patent:** **** Dec. 9, 2014**

(54) **SPHYGMOMANOMETER**

(56) **References Cited**

(71) Applicants: **Fumie Shibata**, Tokyo (JP); **Yukiko Mitsunami**, Otsu (JP)

U.S. PATENT DOCUMENTS

(72) Inventors: **Fumie Shibata**, Tokyo (JP); **Yukiko Mitsunami**, Otsu (JP)

D373,419 S *	9/1996	Muramatsu et al.	D24/165
D403,070 S *	12/1998	Maeda et al.	D24/165
D426,637 S *	6/2000	Ochi et al.	D24/165
D535,028 S *	1/2007	Kobayashi et al.	D24/165
D550,844 S *	9/2007	Gutmann et al.	D24/165
D589,150 S *	3/2009	Kato	D24/167
D641,880 S *	7/2011	Noguchi et al.	D24/165
D665,501 S *	8/2012	Shibata et al.	D24/165
D690,815 S *	10/2013	Uozumi et al.	D24/165
2005/0256411 A1 *	11/2005	Yang	600/490

(73) Assignee: **Omron Healthcare Co., Ltd.**, Kyoto (JP)

(**) Term: **14 Years**

* cited by examiner

(21) Appl. No.: **29/447,612**

Primary Examiner — Anhdao Doan

(22) Filed: **Mar. 5, 2013**

(74) *Attorney, Agent, or Firm* — Capitol City TechLaw

(30) **Foreign Application Priority Data**

(57) **CLAIM**

Sep. 7, 2012 (JP)	2012-021539
Sep. 7, 2012 (JP)	2012-021540
Sep. 7, 2012 (JP)	2012-021541

The ornamental design for a sphygmomanometer, as shown and described.

(51) **LOC (10) Cl.** **24-02**

DESCRIPTION

(52) **U.S. Cl.**

USPC **D24/165**

(58) **Field of Classification Search**

USPC D24/165-168, 186, 107; D10/75, 98;
600/301, 481-483, 485, 490, 493-495,
600/500, 503, 509; 128/900

FIG. 1 is a front, bottom, and right side perspective view of a sphygmomanometer showing our new design;
FIG. 2 is a front view thereof;
FIG. 3 is a rear view thereof;
FIG. 4 is a top view thereof;
FIG. 5 is a bottom view thereof;
FIG. 6 is a right side view thereof; and,
FIG. 7 is a left side view thereof.
The broken lines shown in the figures are included for the purpose of illustrating portions of the sphygmomanometer that form no part of the claimed design.

See application file for complete search history.

1 Claim, 7 Drawing Sheets

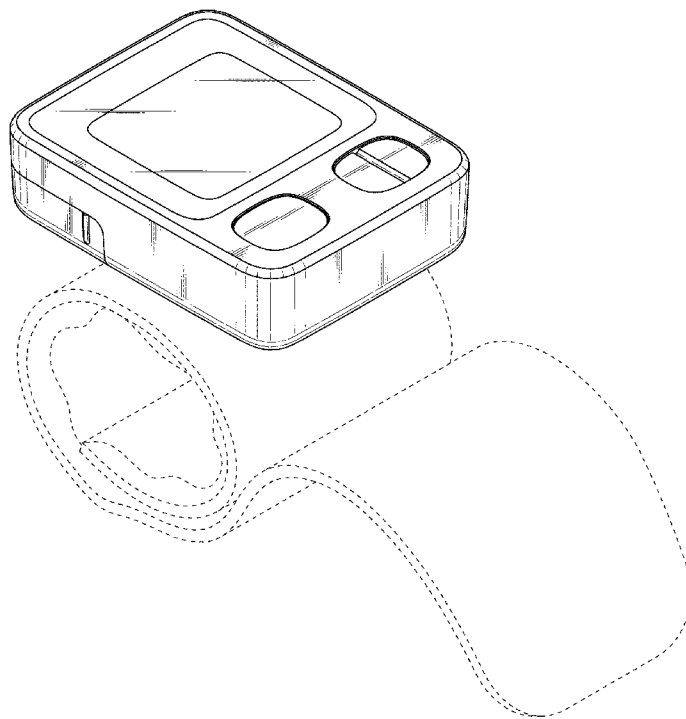

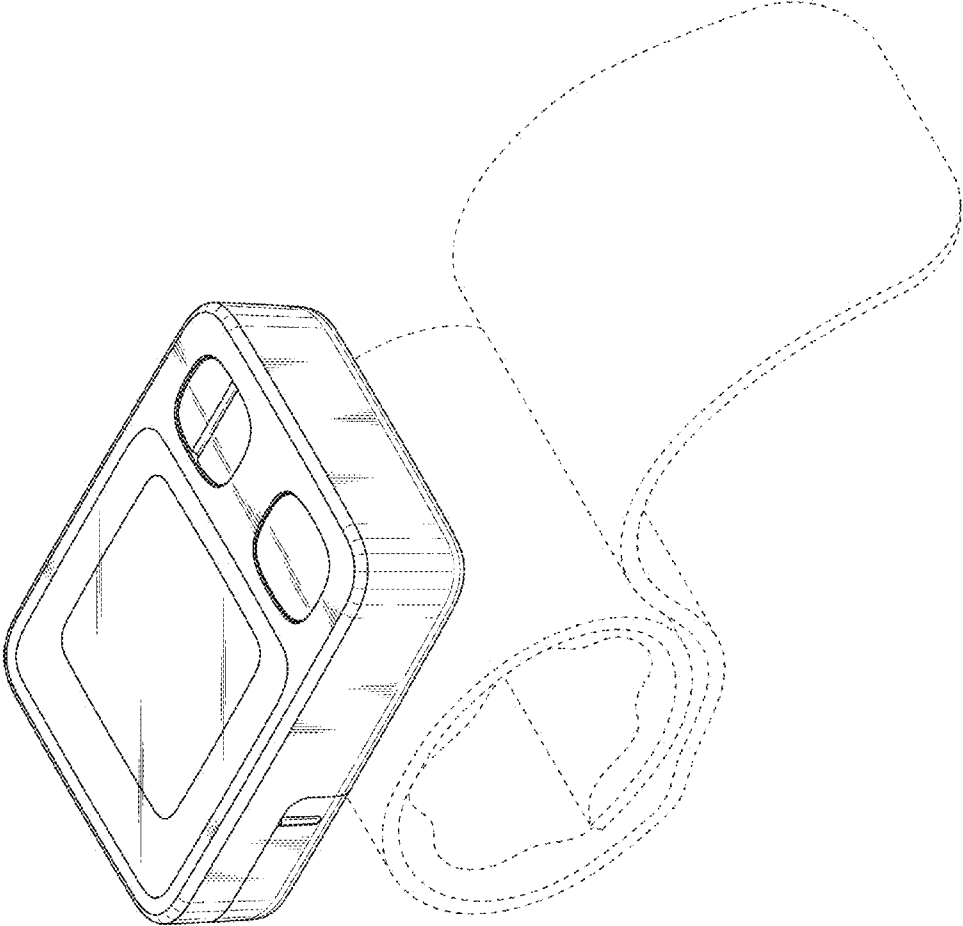

Fig. 1

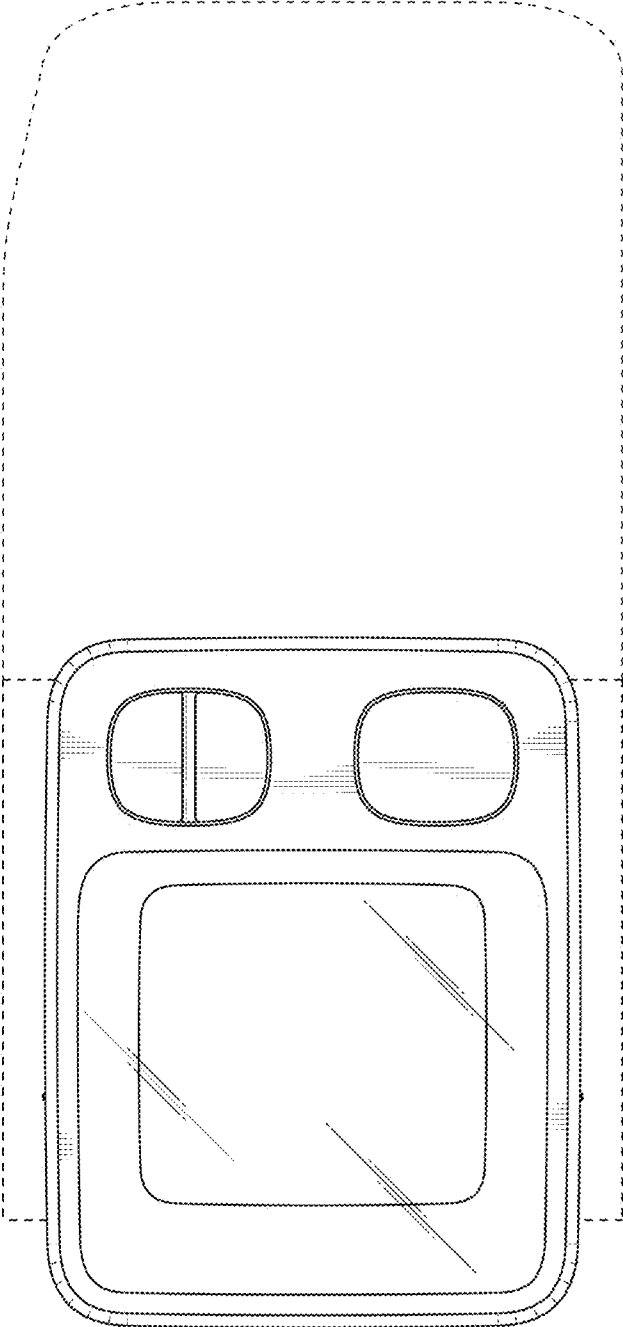

Fig. 2

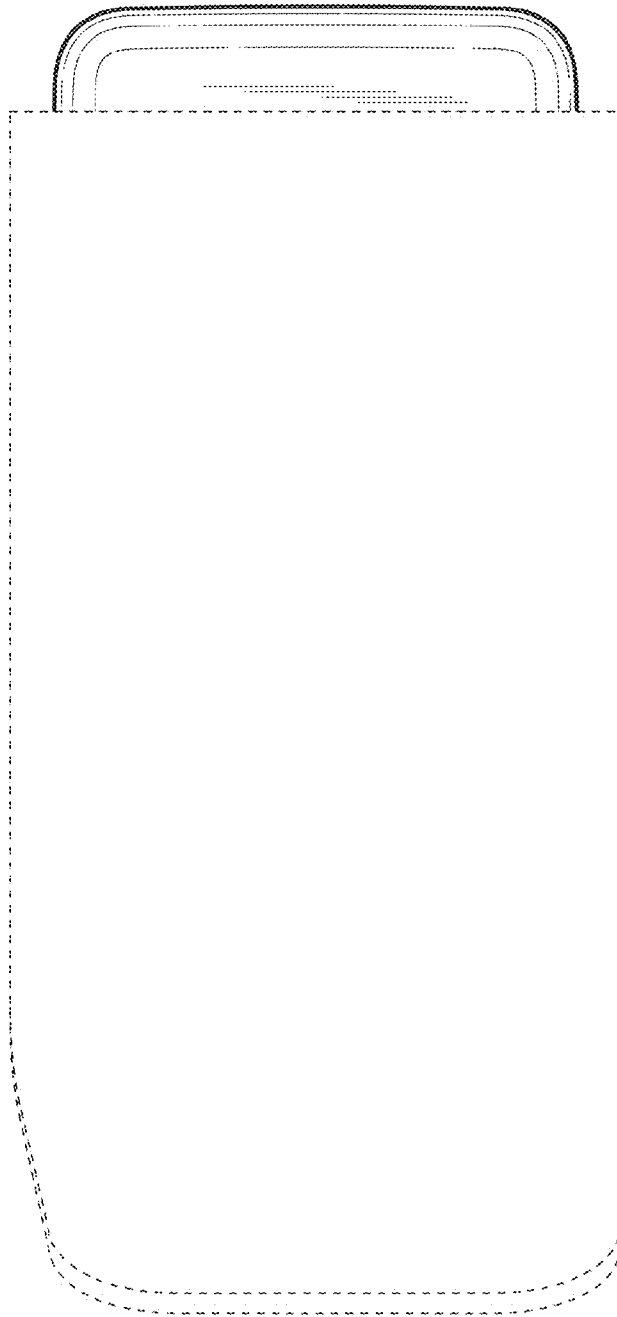

Fig. 3

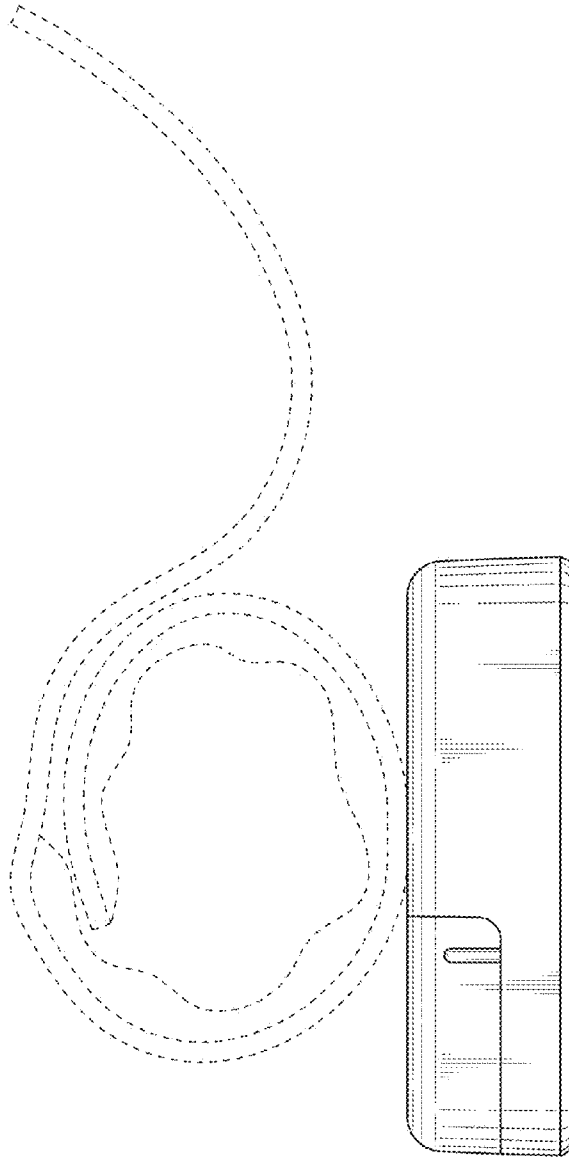

Fig. 4

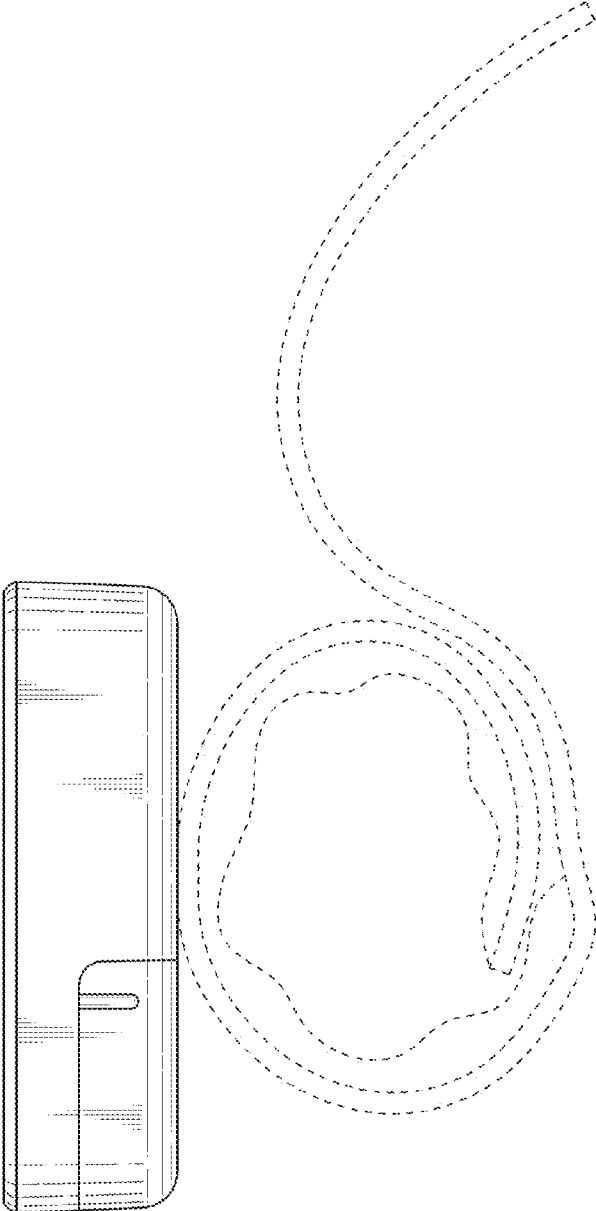

Fig. 5

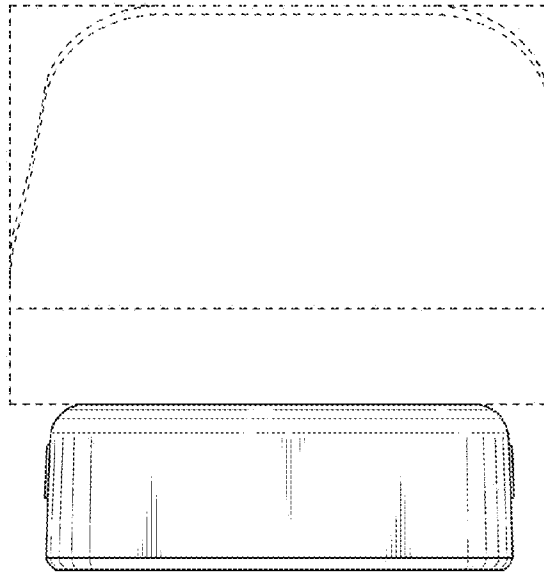

Fig. 6

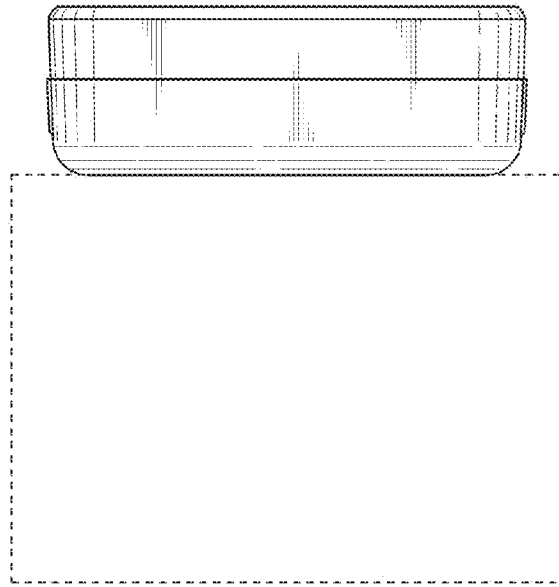

Fig. 7