



US 20060261700A1

(19) **United States**

(12) **Patent Application Publication**

Du et al.

(10) **Pub. No.: US 2006/0261700 A1**

(43) **Pub. Date: Nov. 23, 2006**

(54) **METHOD OF MAKING ARMATURE AND POWER TOOL; ELECTRIC MOTOR AND ARMATURE THEREFOR**

in-part of application No. 09/756,959, filed on Jan. 9, 2001, now abandoned.

(76) Inventors: **Hung T. Du**, Reistertown, MD (US);
Joshua F. West, Towson, MD (US);
Michael R. Sell, Bel Air, MD (US)

(60) Provisional application No. 60/395,251, filed on Jul. 12, 2002.

Publication Classification

Correspondence Address:
HARNES, DICKEY & PIERCE, P.L.C.
P.O. BOX 828
BLOOMFIELD HILLS, MI 48303 (US)

(51) **Int. Cl.**
H02K 1/04 (2006.01)
(52) **U.S. Cl.** **310/234; 310/43; 310/261**

(21) Appl. No.: **11/491,454**
(22) Filed: **Jul. 21, 2006**

(57) **ABSTRACT**

Related U.S. Application Data

(60) Division of application No. 10/616,871, filed on Jul. 10, 2003, now Pat. No. 7,096,566, which is a continuation-in-part of application No. 10/365,065, filed on Feb. 12, 2003, now Pat. No. 7,013,552, which is a division of application No. 09/836,517, filed on Apr. 17, 2001, now abandoned, which is a continuation-

An armature for an electric motor has a lamination stack having slots in which magnet wires are wound. An armature shaft extends coaxially through the lamination stack and a commutator is disposed on the armature shaft to which ends of the magnet wires are electrically coupled. Plastic is molded around the magnet wires and the armature shaft to increase the stiffness of the armature shaft, which increases the critical frequency of the armature shaft. In an aspect, an electric motor has such an armature. In an aspect, a power tool has an electric motor having such an armature.

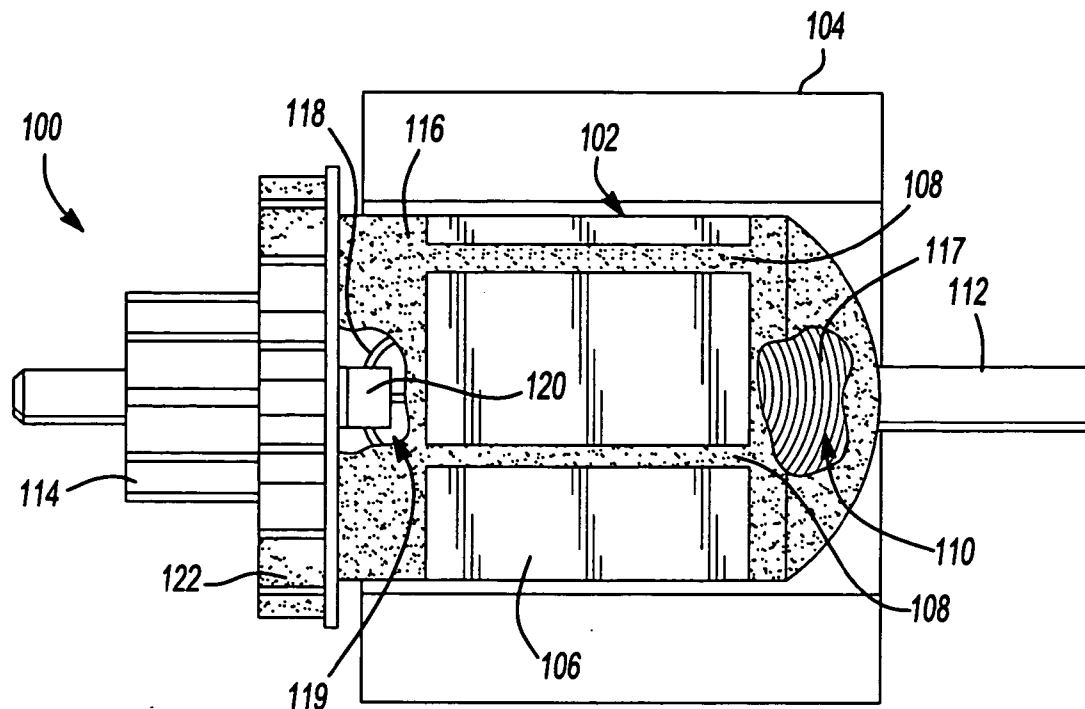

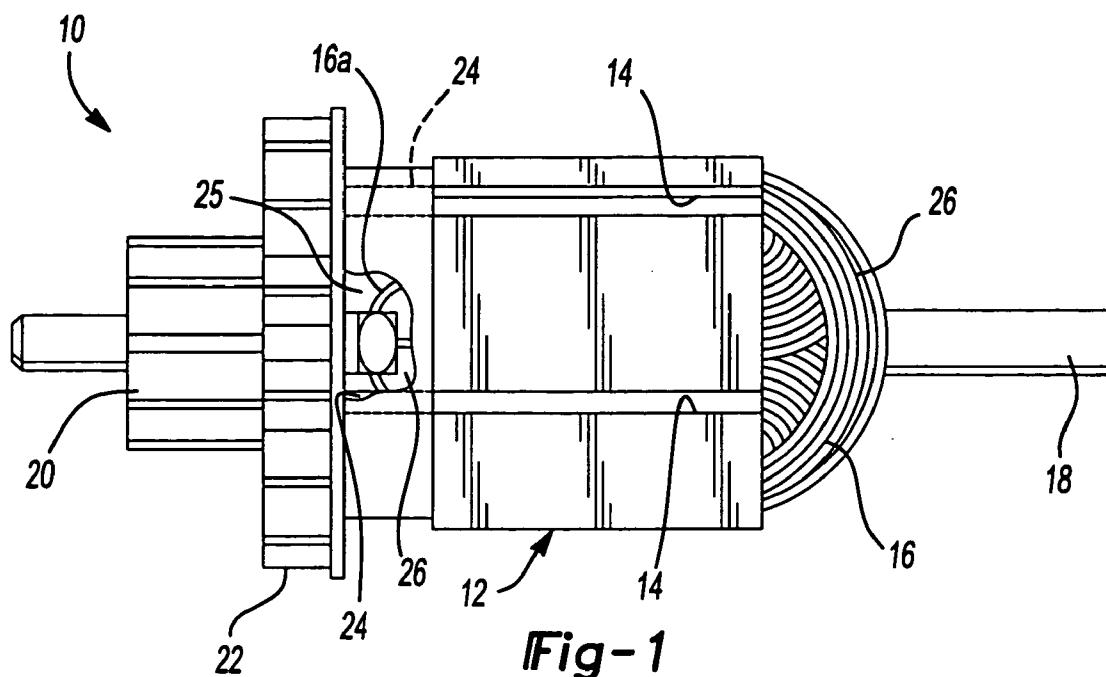

Fig-1
PRIOR ART

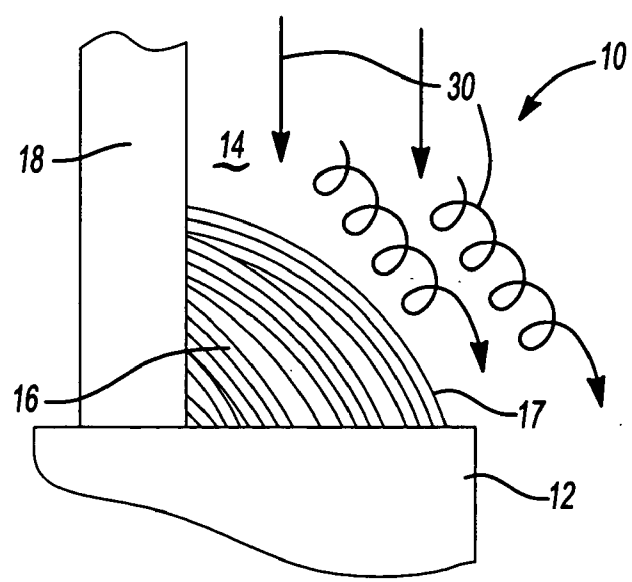
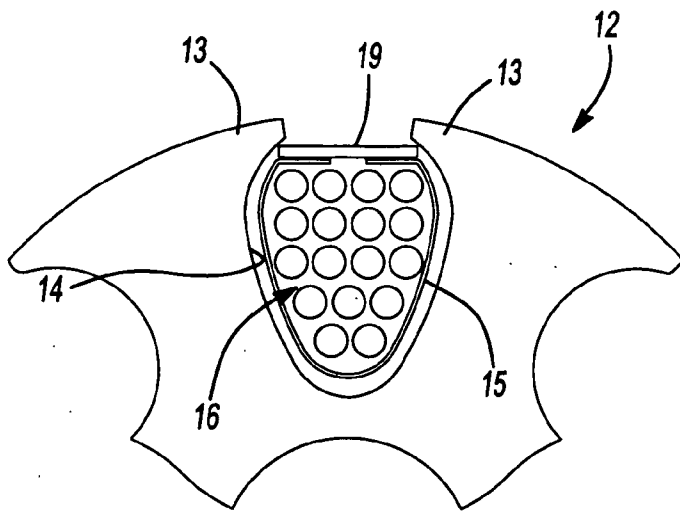
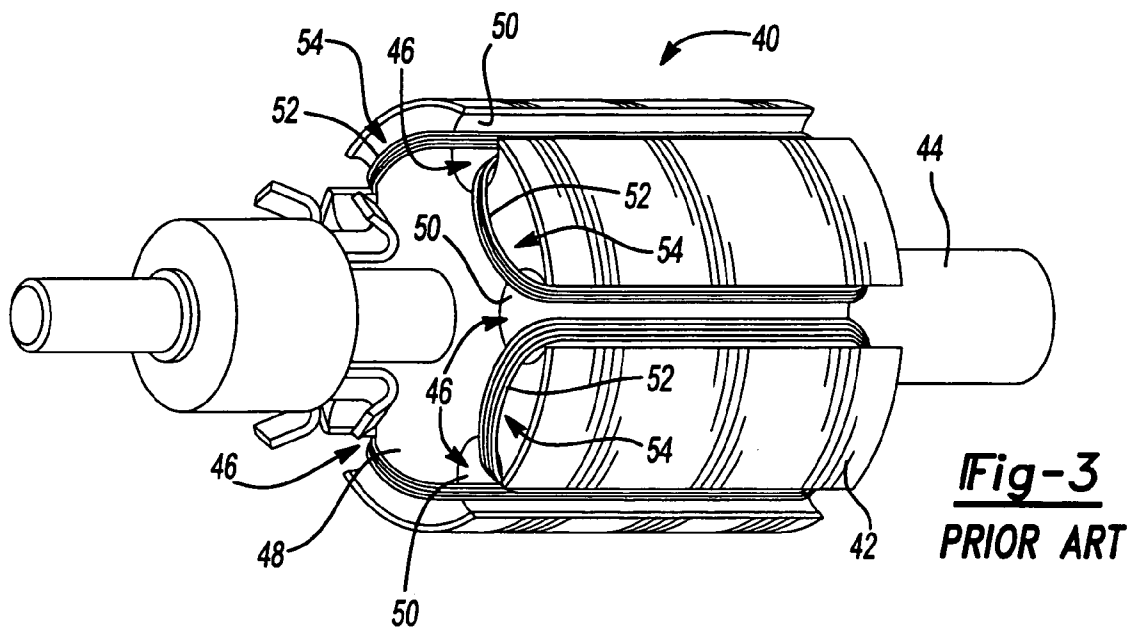

Fig-2
PRIOR ART



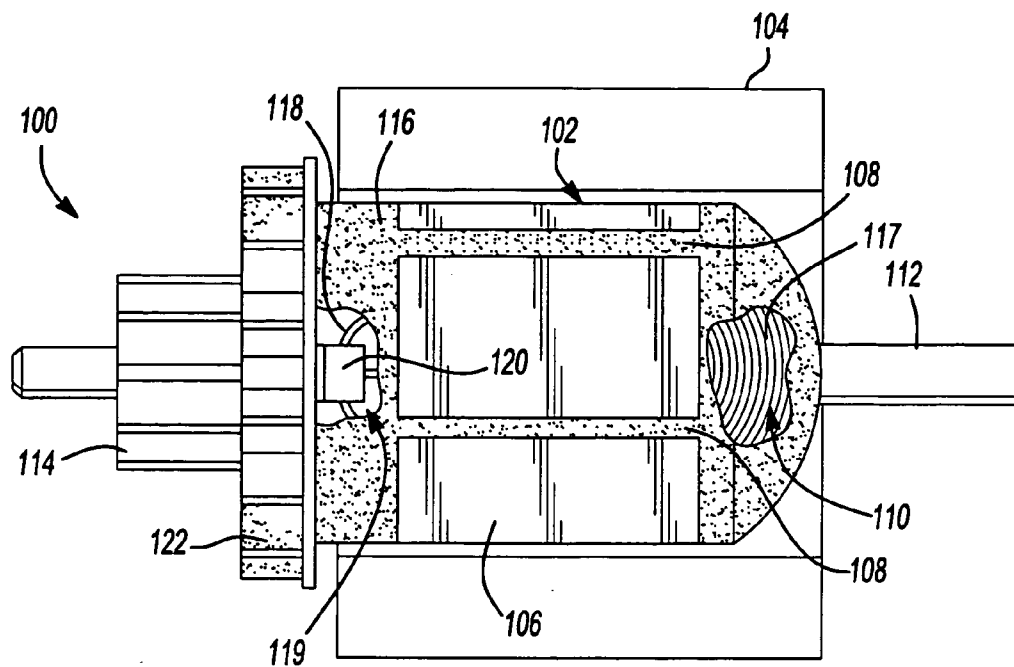

Fig-5

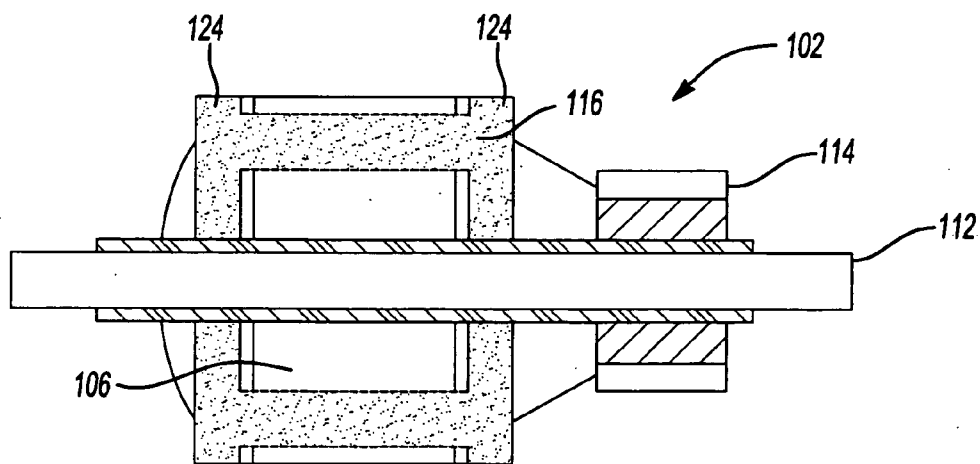

Fig-6

Fig-7

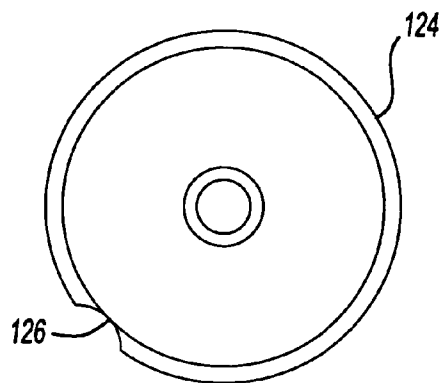

Fig-8

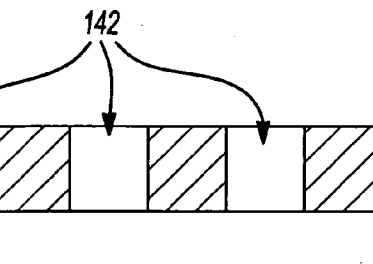
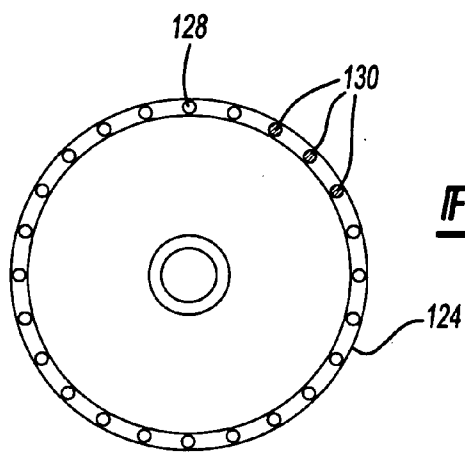

Fig-9

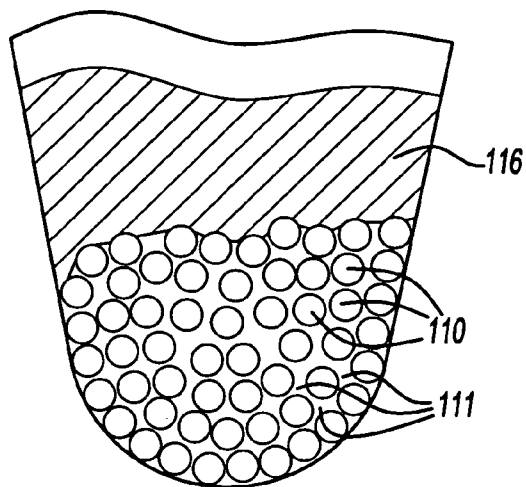

Fig-10

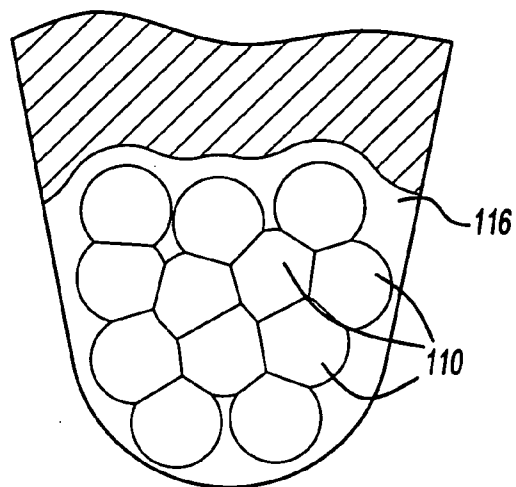

Fig-11

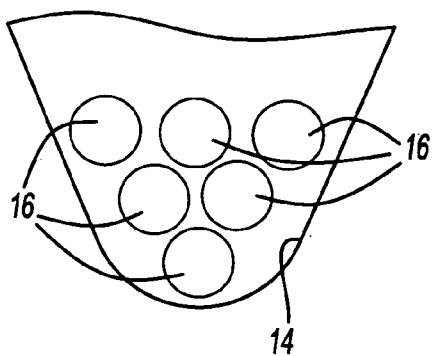

Fig-12
PRIOR ART

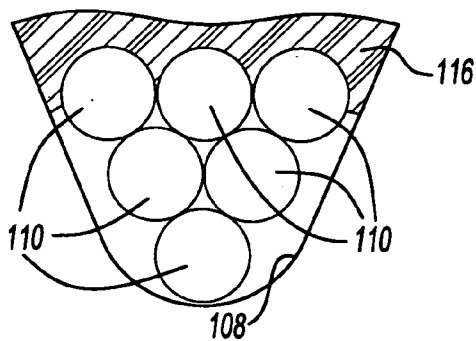

Fig-13

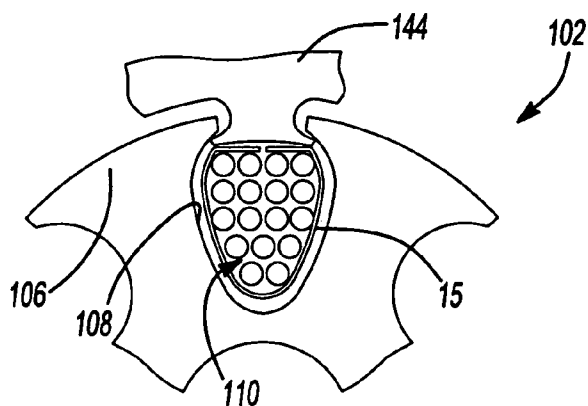

Fig-14

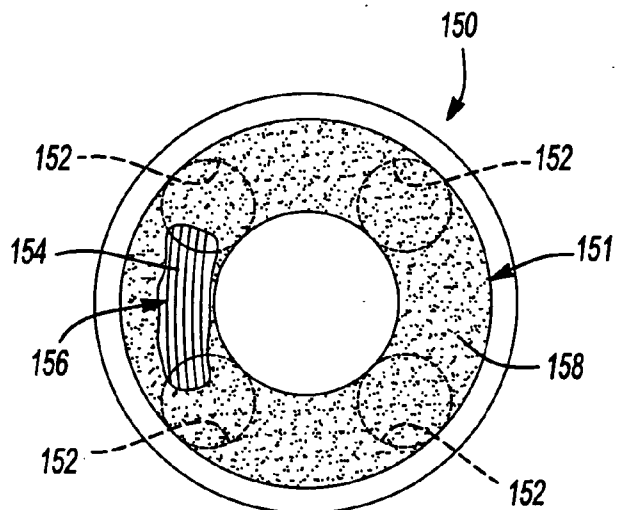

Fig-15

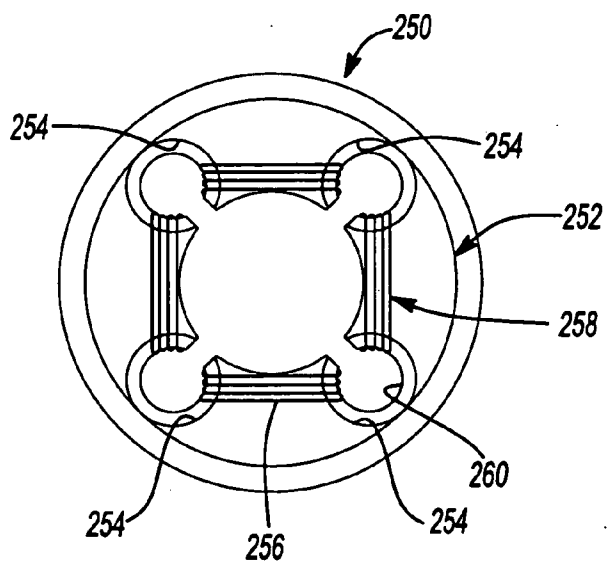

Fig-16

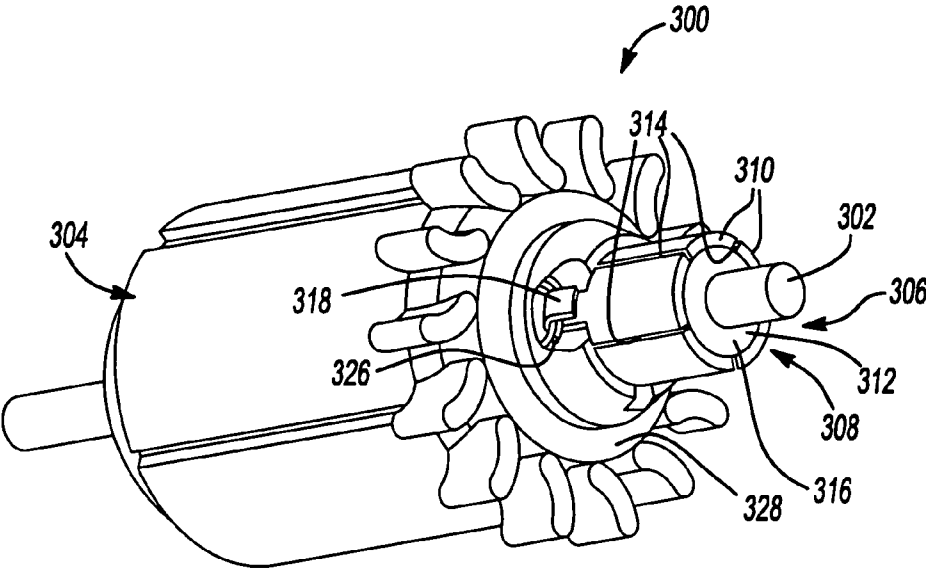

Fig-17

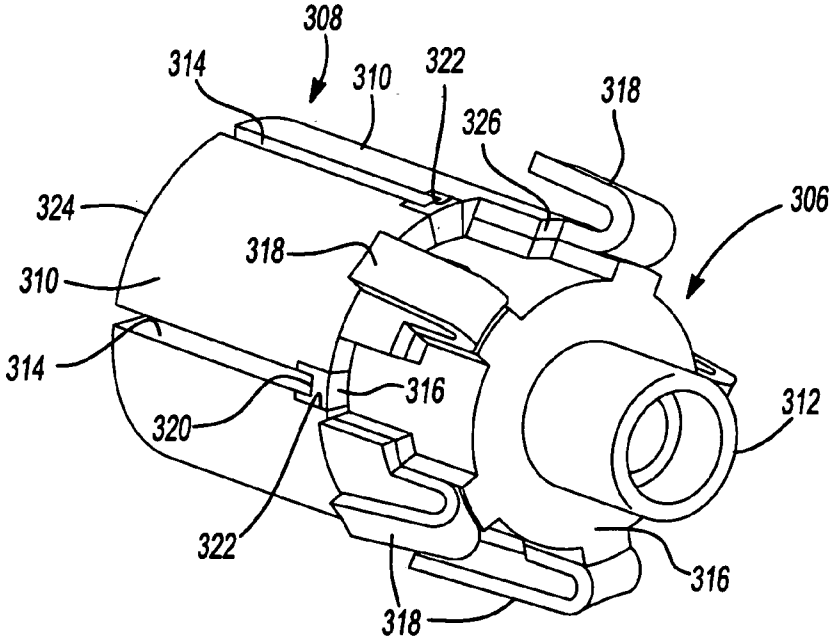

Fig-18

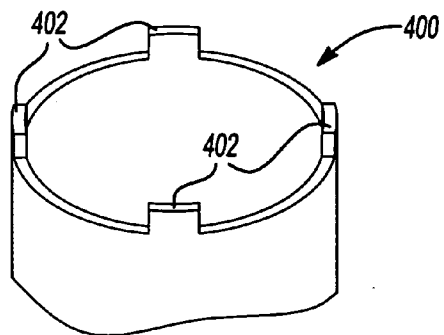

Fig-19

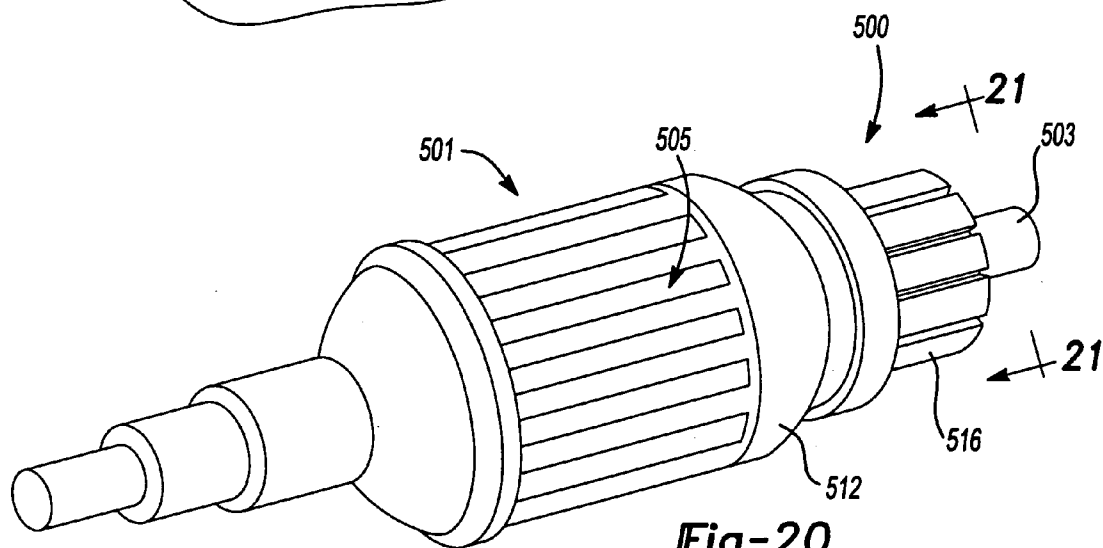

Fig-20

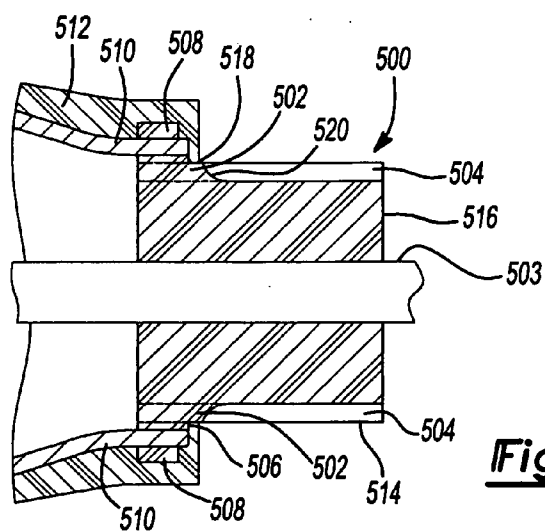

Fig-21

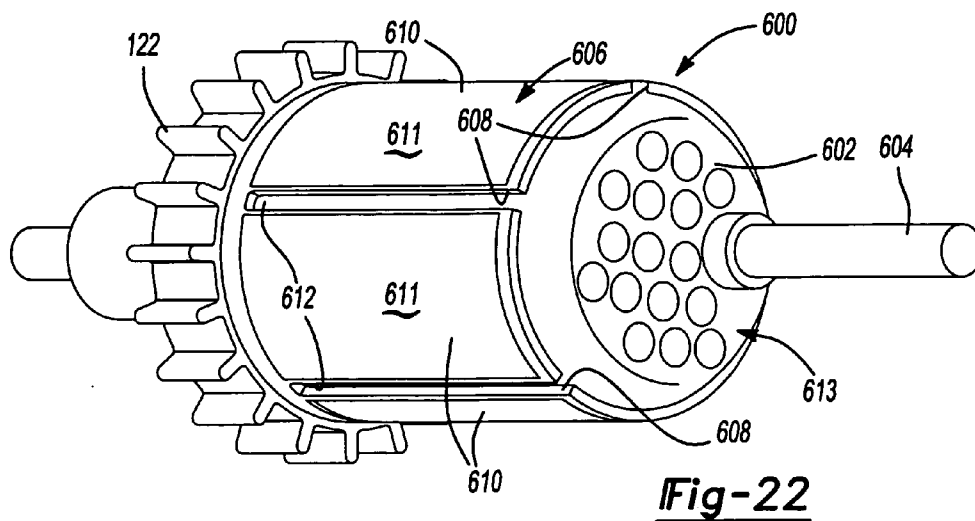

Fig-22

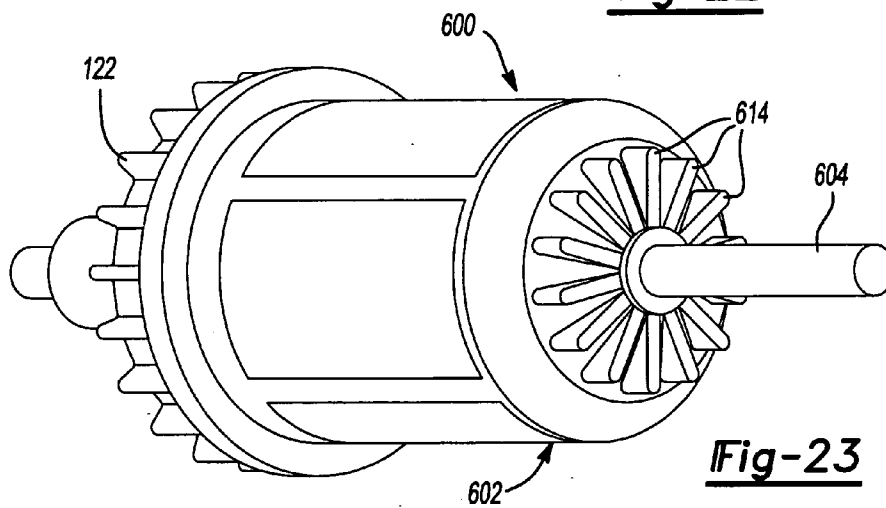

Fig-23

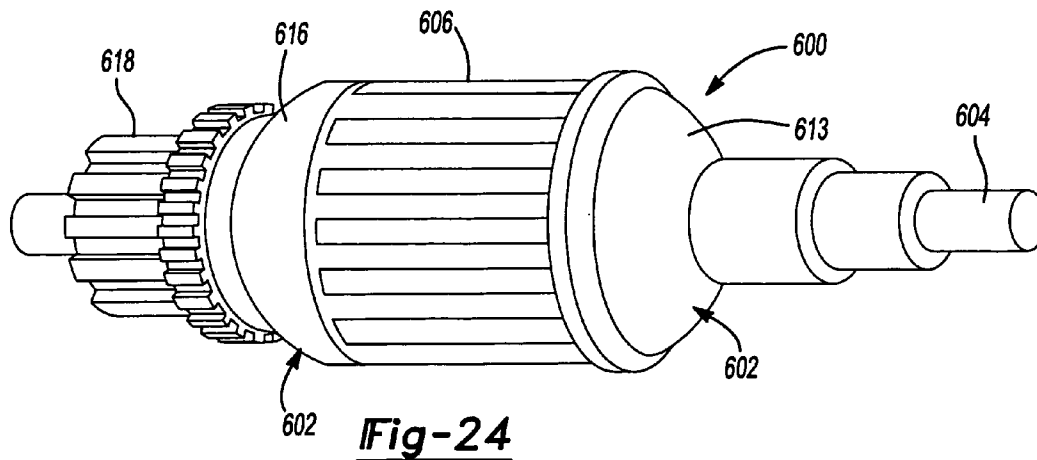

Fig-24

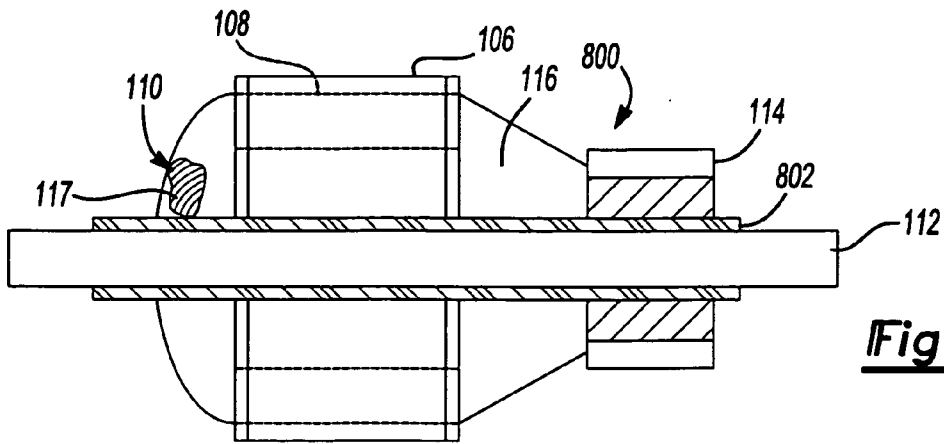

Fig-29

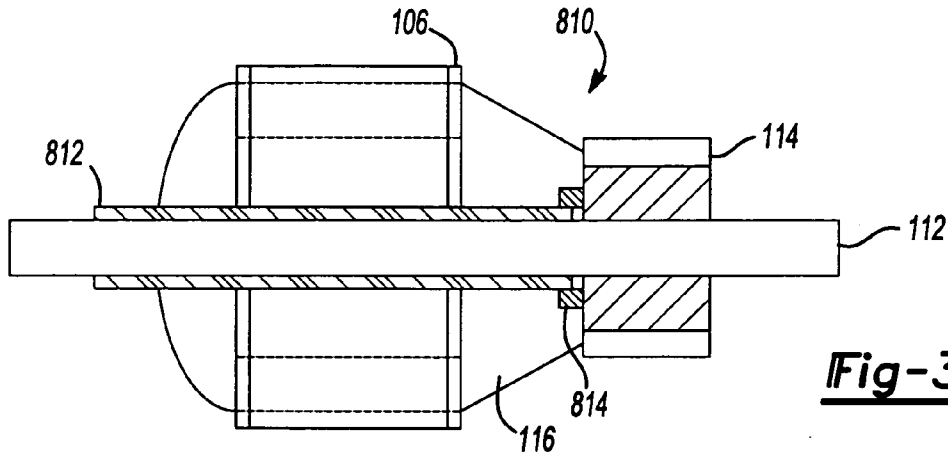

Fig-30

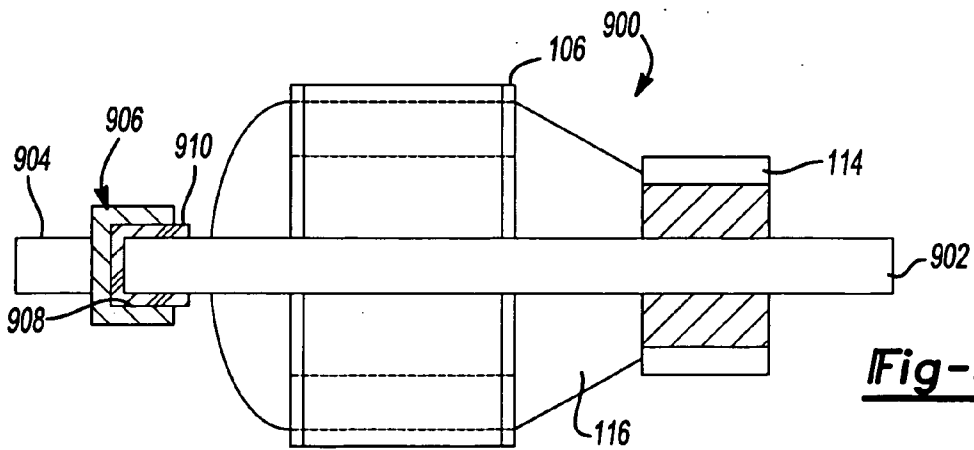

Fig-31

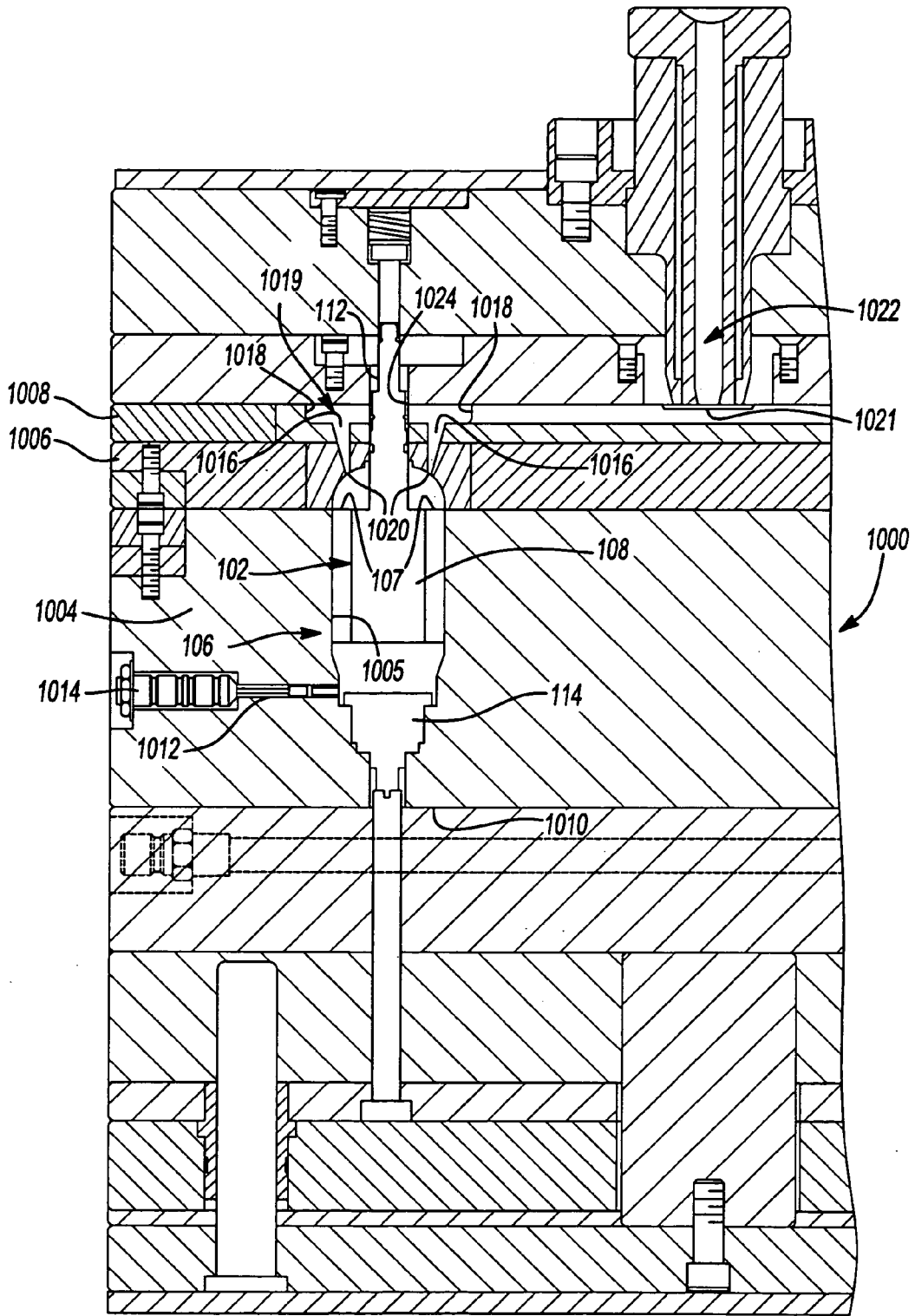
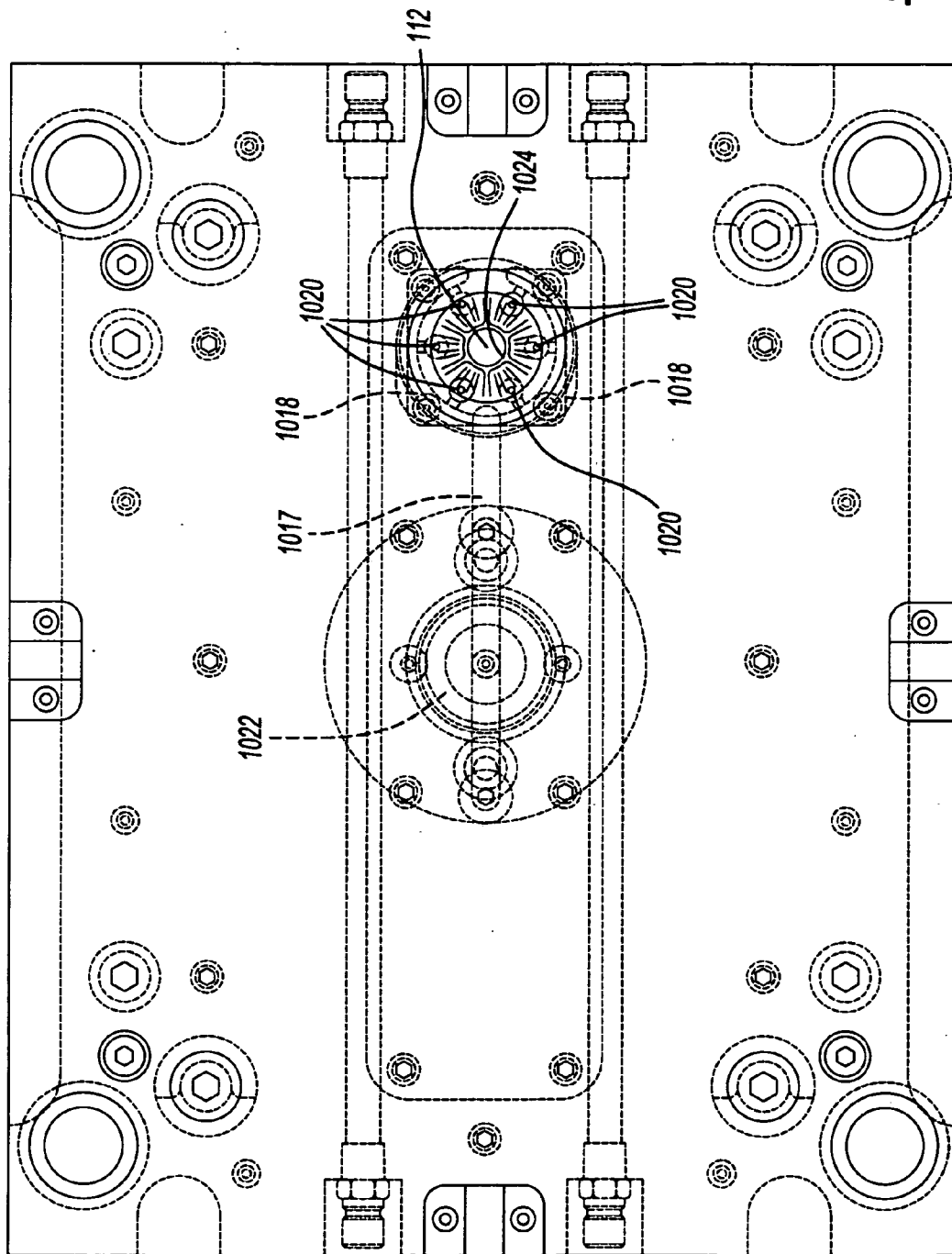
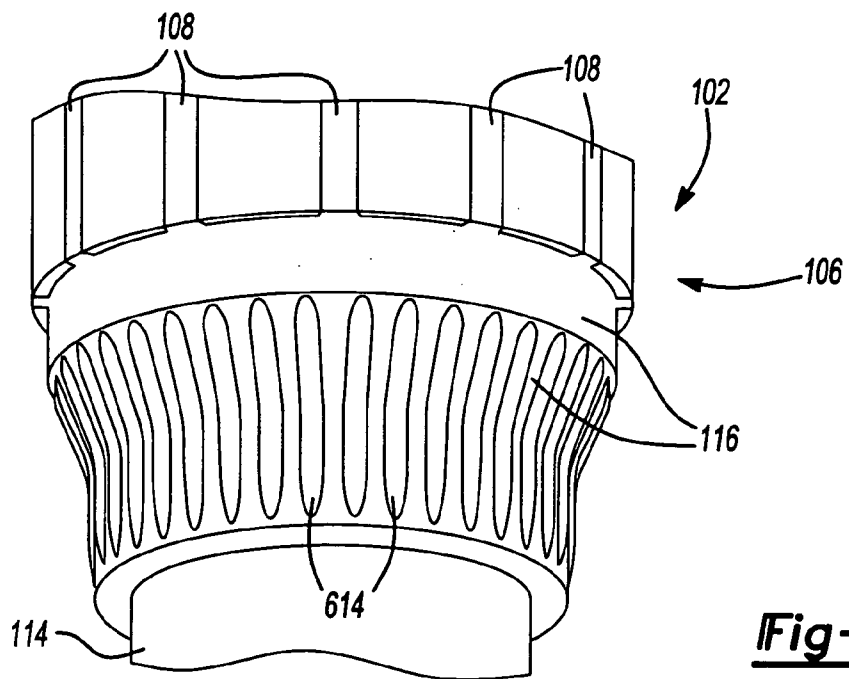
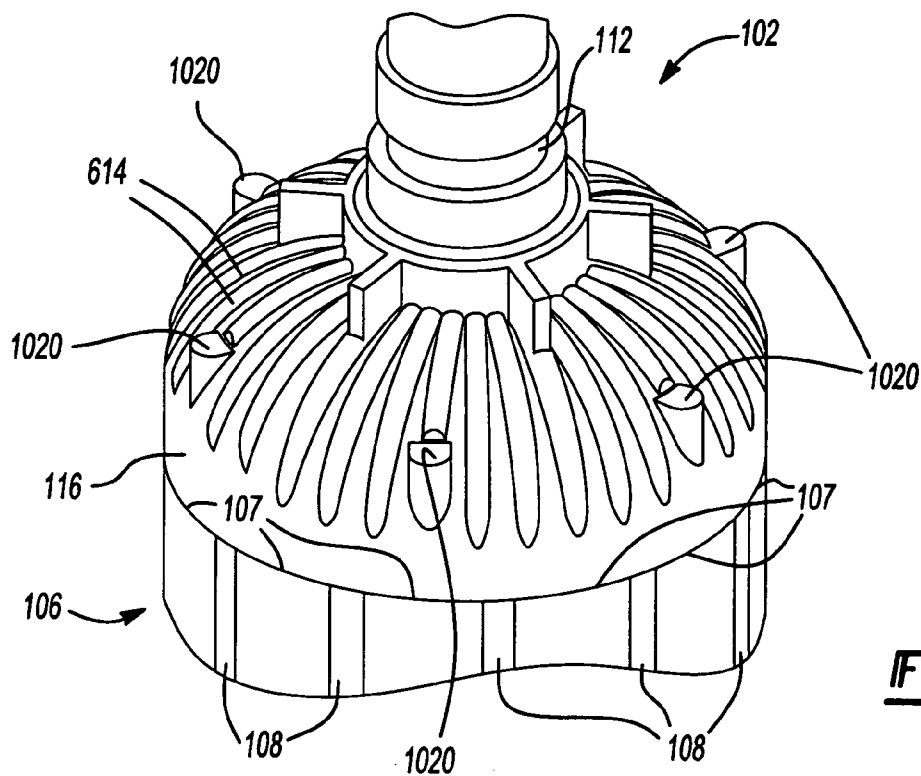

Fig-32

Fig-33





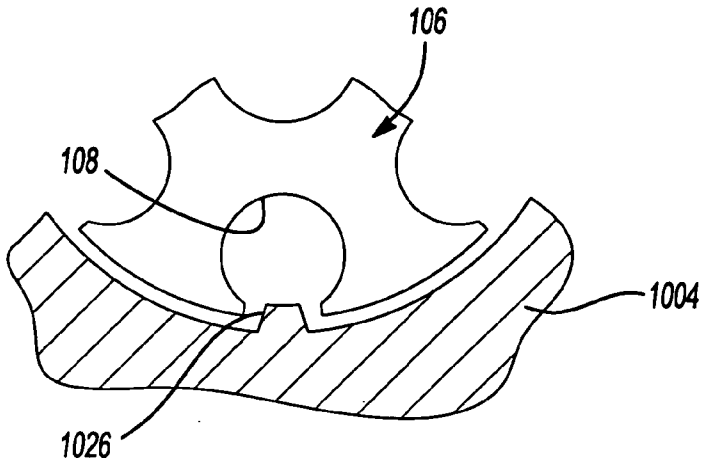

Fig-36

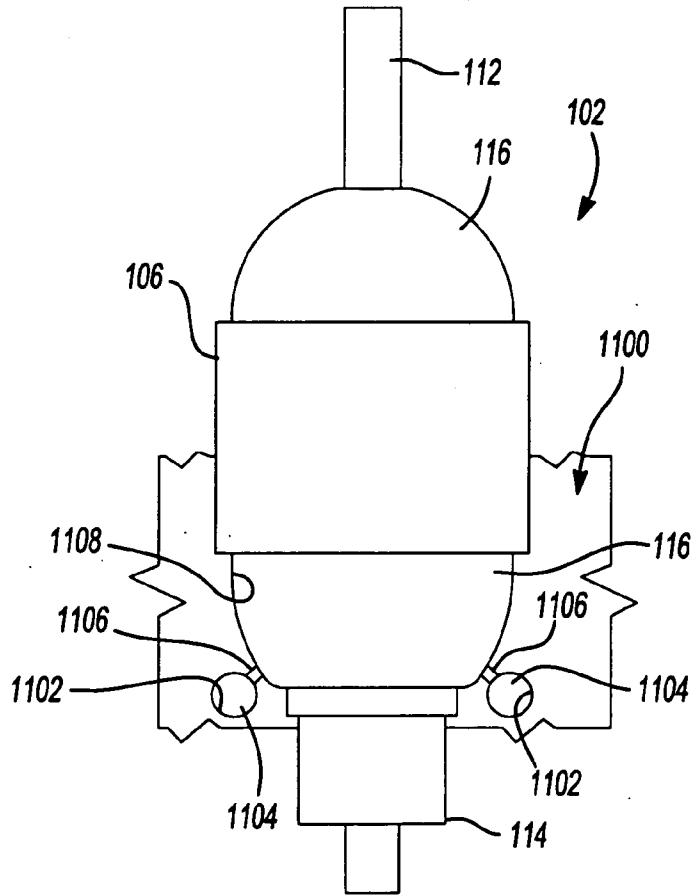

Fig-37

METHOD OF MAKING ARMATURE AND POWER TOOL; ELECTRIC MOTOR AND ARMATURE THEREFOR

CROSS-REFERENCE TO RELATED APPLICATIONS

[0001] This application is a divisional of U.S. patent application Ser. No. 10/616,871 filed on Jul. 10, 2003, which is a continuation-in-part of U.S. patent application Ser. No. 10/365,065 filed on Feb. 12, 2003, which is a divisional of U.S. patent application Ser. No. 09/836,517 filed on Apr. 17, 2001, which is a continuation-in-part of U.S. patent application Ser. No. 09/756,959 filed Jan. 9, 2001. U.S. Ser. No. 10/616,871 claims the benefit of U.S. Provisional Application No. 60/395,251 filed on Jul. 12, 2002.

TECHNICAL FIELD

[0002] This invention relates to dynamoelectric machines, and more particularly to a dynamoelectric machine having a coil structure encapsulated with a thermally conductive plastic.

BACKGROUND OF THE INVENTION

[0003] Dynamoelectric machines are machines that generate electric power or use electric power. Common types of dynamoelectric machines are alternators, generators, and electric motors.

[0004] Electric motors are used in a wide variety of applications involving power tools such as drills, saws, sanding and grinding devices, yard tools such as edgers and trimmers, just to name a few such tools. These devices all make use of electric motors having an armature and a field, such as a stator. The armature is typically formed from a lamination stack or core around which a plurality of windings of magnet wires are wound. The lamination stack is formed to have a plurality of poles around which the magnet wires are wound. In this regard, the lamination stack may be formed with a plurality of slots in which the magnet wires are wound. Insulators are typically provided between the magnet wires and the lamination stack. Magnet wires, as that term is commonly understood, are wires of the type conventionally used to wind coils in electric machines, such as armatures and stators. The magnet wires are coupled at their ends to a commutator, such as to tangs when the commutator is a tang type commutator, disposed on an armature shaft extending coaxially through the lamination stack.

[0005] The stator is also typically formed from a lamination stack around which a plurality of windings of magnet wires are wound. The ends of the magnet wires typically have terminals affixed that are then coupled to a source of electrical power. The lamination stack is formed to have a plurality of poles around which the magnet wires are wound. In this regard, the lamination stack may be formed with a plurality of slots in which the magnet wires are wound. Insulators are typically provided between the magnet wires and the lamination stack.

[0006] In the manufacturing process for the armature described above, once the magnet wires have been secured to the commutator, a "trickle" resin is applied over the magnet wires and over the ends of the magnet wires where they attach to tangs associated with the commutator. The

process of applying the trickle resin is a somewhat difficult process to manage to obtain consistent results. It also has a number of drawbacks, not the least of which is the cost and difficulty of performing it with reliable, consistent results.

[0007] Initially, the trickle process requires the use of a relatively large and expensive oven to carefully preheat the partially assembled armatures to relatively precise temperatures before the trickle resin can be applied. The temperature of the trickle resin also needs to be carefully controlled to achieve satisfactory flow of the resin through the slots in the lamination stack of the armature. It has proven to be extremely difficult to achieve consistent, complete flow of the trickle resin through the slots in the lamination stack. As such, it is difficult to achieve good flow inbetween the magnet wires with the trickle resin. A cooling period must then be allowed during which air is typically forced over the armatures to cool them before the next manufacturing step is taken. Further complicating the manufacturing process is that the trickle resin typically has a short shelf life, and therefore must be used within a relatively short period of time. The manufacturing process for making wound stators may involve a similar trickle resin process.

[0008] Referring to **FIG. 1**, there is illustrated a prior art armature **10** made in accordance with a conventional manufacturing process incorporating the trickle resin application steps described hereinbefore. The armature **10** incorporates a lamination stack **12** having a plurality of longitudinal slots **14** disposed circumferentially therearound. Wound within the slots **14** is a large plurality of magnet wires **16** forming coils. An armature shaft **18** extends coaxially through the lamination stack **12** and includes a commutator **20**. An independently formed plastic fan **22** is secured, typically by adhesives, to the lamination stack **12**. The fan **22** typically includes a plurality of legs **24** which project into the slots **14**, thus taking up space which would more preferably be occupied by the magnet wires **16**. Trickle resin **26** is applied over the magnet wires **16**, in the slots **14**, and also at the tangs **25** where the ends **16a** of the magnet wires **16** attach to the commutator **20**.

[0009] Abrasive particles are drawn in and over the armature by the armature's fan, particularly when the armature is used in tools such as grinders and sanders. As shown particularly in **FIG. 2**, the air flow, shown by arrows **30**, impinges magnet wires **16** of end coils **17** (the portion of the coils of magnet wires that extend around the ends of the lamination stack **12** between the slots **14** in the lamination stack **12**). The air flow **30** contains abrasive particles and the impingement of these abrasive particles on magnet wires **16** can wear away the insulation of magnet wires **16**.

[0010] With present day manufacturing techniques, an additional or secondary operation is often required to protect the armature (and specifically the magnet wires) from the abrasive particles. Such secondary operations include a coating of higher viscosity trickle resin, an epoxy coating, or wrapping the wires, such as with cotton, string or the like. This serves to further increase the manufacturing cost and complexity of the armature.

[0011] Still another drawback with the trickle process is the relatively high number of armatures which are often rejected because of problems encountered during the process

of applying the trickle resin to an otherwise properly constructed armature. Such problems can include contamination of the commutator of the armature by the trickle resin during the application process, as well as uneven flow of the trickle resin if the pump supplying the resin becomes momentarily clogged. Accordingly, the difficulty in controlling the trickle resin application process produces a relatively large scrap rate which further adds to the manufacturing cost of electric motors.

[0012] Slot insulators and end spiders of armatures have been formed by insert molding the armature shaft and lamination stack in plastic. FIG. 3 shows such a prior art armature 40 having a lamination stack 42 on a shaft 44. Lamination stack 42 has a plurality of slots 46. The plastic is molded underneath the lamination stack 42 and around shaft 44 to insulate the shaft 44 from the lamination stack 42. The plastic is also molded to form end spiders 48 and molded in slots 46 to form slot liners 50. Slot liners 50 insulate the windings 52 from lamination stack 42 after the windings 52 have been wound in the slots 46 to form coils 54.

[0013] The plastic used in molding the prior art armature 40 has been plastic that is not thermally conductive, such as nylon or PPS. This can result in problems in dissipating the heat generated in the coils 54 during the operation of the motor in which armature 40 is used.

[0014] Most armatures or rotors used in dynamoelectric machines, such as motors and generators, are dynamically balanced to reduce the vibration force transmitted to the motor housing by way of the bearings. Dynamic balancing requires that material be added to or removed from the ends of the armature. The most beneficial places to do this are on planes near to the bearing planes at the largest possible radius. However, for practical reasons, universal motor armatures and permanent magnet motor armatures are usually balanced by selectively removing material from the surface of the iron core (also called the lamination stack).

[0015] This balancing process has a number of disadvantages. First, the planes in which the material are removed are located within the length of the lamination stack and thus are relatively distant from the bearing planes where the imbalance forces are transmitted to the rest of the product. Second, removal of material from the motor's active iron core (lamination stack) has a negative effect on performance, particularly, torque ripple. Third, balancing by removing material from the surface of the lamination stack requires that the tooth tops of the lamination stack be thicker than needed for spreading magnetic flux. The thicker tooth tops rob winding space from the slots in the lamination stack in which magnet wires are wound. Fourth, the surface of the lamination stack is not homogenous. It consists of iron at the tooth tops and air or resin in the winding slot area. This non-homogeneity presents a more difficult computation to the dynamic balancing machine that must decide how much material to remove and where to remove it from. Consequently, the dynamic balance machines often must make repetitive corrective passes during which even more iron is removed from the lamination stack, further reducing performance.

[0016] Coil stays have typically been used to hold the magnet wires, such as magnet wires 16, in the slots, such as slots 14, in the lamination stack, such as lamination stack 12.

FIG. 4 shows one of slots 14 of lamination stack 12 of prior art armature 10 (FIG. 1) disposed between opposed poles 13 of lamination stack 12 and magnet wires 16 wound in slot 14. A slot liner 15, typically made of a paper insulation, is disposed in slot 14 between the magnet wires 16 and walls of lamination stack 12. Magnet wires 16 are retained in slot 14 by a coil stay 19, which is illustratively made of vulcanized fibers that are both electrically and thermally insulative. Such prior art coil stays have certain undesirable characteristics. First, they occupy space that could otherwise be filled with magnet wires 16. Second, the poor thermal conductivity of the coil stay material limits the amount of heat that can be transferred to the surface of lamination stack 12.

[0017] As is known, the power of a motor having magnet wires wound in slots of a lamination stack is a function of the current flowing through the magnet wires and the number of turns of magnet wires. A motor having a given output, i.e., $\frac{1}{10}$ horsepower, $\frac{1}{8}$ horsepower, $\frac{1}{4}$ horsepower, requires that a certain number of turns of magnet wires that can carry a given current be used. The ability of the magnet wires to carry the given current is a function of the size (diameter) of magnet wires. The size of the magnet wires that must be used to wind the given number of turns of the magnet wires in turn dictates the size of the slots in which they are wound. That is, the slots must be large enough to hold the required number of turns of magnet wires.

[0018] If a larger size magnet wire can be used to wind the magnet wires, higher power can be achieved due to the decreased resistance of the larger size magnet wire compared with the smaller size magnet wire. However, using a larger size magnet wire to wind the magnet wires would typically require larger slots to accommodate the required number of turns of the larger size magnet wire, which in turn would require a larger lamination stack. Thus the armature would be larger.

[0019] Mains driven power tools, tools driven from power mains such as 120 VAC, are often double-insulated to protect the user from electric shock. Double-insulation requires two separate levels of electrical insulation: functional insulation and protective insulation. Functional insulation electrically insulates conductors from one another and from non-touchable dead-metal parts of the armature. An example of a non-touchable dead metal part is the lamination stack of the armature, such as lamination stack 12 (FIG. 1). The functional insulation system includes the core insulation, magnet wire film, and the resin matrix that bonds the whole together. Core insulation could also consist of epoxy coatings applied by a powder coating process.

[0020] The protective insulation consists of an electrically insulative tube or sleeve disposed between the touchable dead-metal shaft, such as shaft 18 (FIG. 1), and the rest of the armature structure. The shaft is considered touchable since it is in conductive contact with exposed conductive parts of the tool, such as a metal gearbox and/or metal spindle or chuck. In order to provide protection at the end of the tool's functional life due to abusive loads and burnout, the protective insulation barrier must have electrical, thermal, and structural properties that are superior to those of the functional insulation system. Therefore, the insulating tube or sleeve is usually constructed of high-temperature, glass reinforced thermosetting resin. Other materials such as

ceramic, mica, and composites of these material could also be used to make the insulating tube or sleeve.

SUMMARY OF THE INVENTION

[0021] In an aspect of the invention, an armature for an electric motor has an armature shaft having a lamination stack thereon. The armature shaft and lamination stack are insert molded in thermally conductive plastic. In an aspect of the invention, the plastic increases stiffness and thus increases the critical speed of the armature. In an aspect of the invention, the mass of plastic, its distribution, or both are varied to adjust the spinning inertia of the armature. In another aspect of the invention, the geometry of the plastic, its mechanical properties, or both are varied to adjust the resonant frequency (critical speed) of the armature.

[0022] In another aspect of the invention, bondable wire (which is wire that has a layer of heat activated adhesive thereon) is used to wind the coils of a coil structure for a dynamoelectric machine, such as an armature for an electric motor or a stator for an electric motor. Plastic, preferably thermally conductive plastic, is molded around the bondable wire. The heat of the plastic as it is being molded activates the heat activated adhesive on the bondable wire, bonding the wires together.

[0023] In another aspect of the invention, a coil structure for a dynamoelectric machine has wires wound in slots in a lamination stack forming coils. Thermally conductive plastic is molded around the wires at a pressure to at least partially deform the wires into polygonal shapes. The polygonal shapes increase the contact surface area of the wires and enhance heat transfer from the wires.

[0024] In another aspect of the invention, the pressure at which the thermally conductive plastic is molded around the wires is set at a pressure that compacts the wires in the slots in the lamination stack that allows for increased slot fill.

[0025] In an aspect of the invention, increased power is achieved by using a larger size magnet wire. The pressure of the plastic being molded is set to compact the magnet wires so that the same number of turns of magnet wires wound with the larger size magnet wire can be used. The larger size magnet wire has a lower resistance per given length compared with the smaller magnet wires heretofore used for a given size of motor which results in increased power when the same number of turns of magnet wires wound with the larger size magnet wire are used. In a variation of this aspect of the invention, iso-static pressure is used to compact the magnet wires in the slots.

[0026] In another aspect of the invention, the plastic is molded around armature lead wires, the portion of the magnet wires leading to the commutator, and provides support for the armature lead wires.

[0027] In another aspect of the invention, thermally conductive plastic is molded around at least a portion of the magnet wires of an armature to at least partially encase them. In an aspect of the invention, the thermally conductive plastic has thermally conductive additives such as aluminum oxide, boron nitride, or aluminum nitride. In an aspect of the invention, the thermally conductive plastic has phase change additives therein. In an aspect of the invention, the plastic can have a base polymer that is Nylon, PPS, PPA, LCP, or blends.

[0028] In another aspect of the invention, the plastic can be a thermoset and in addition to injection molding, transfer molding or compression molding used to mold the plastic around the armature.

[0029] In another aspect of the invention, a coil structure for a dynamoelectric machine has a lamination stack with a plurality of slots therein. The slots are lined with slot liners formed of thermally conductive plastic. Wires are wound in the slots to form coils. The slot liners enhance heat transfer out of the wires and also electrically insulate the wires from the lamination stack. In an aspect of the invention, thermally conductive plastic is molded to form the slot liners. In an aspect of the invention, the coil structure is an armature for an electric motor and the thermally conductive plastic is also molded to form end spiders and to be disposed between the armature shaft and lamination stack, electrically insulating the lamination stack from the armature shaft.

[0030] In another aspect of the invention, an armature for an electric motor has a lamination stack on a shaft with a tang type commutator mounted on one end of the shaft. The lamination stack has slots in which magnet wires are wound forming coils. Ends of the magnet wires are attached to tangs of the commutator. The commutator has a commutator ring divided into a plurality of segments with slots between the segments. The commutator is notched around an axial inner end with the notches located where axial inner ends of the slots will be once the slots are cut. The notches are filled with plastic when the commutator is made by molding a core of plastic, such as phenolic, in the commutator ring before the commutator ring is mounted on the armature shaft. The slots are then cut in the commutator ring to divide it into segments. The slots are cut axially through the commutator ring and run from an axial distal end of the commutator ring part way into the notches at the axial inner end of the commutator ring. The magnet wires, commutator and armature shaft are at least partially encapsulated in plastic, such as by insert molding. The mold used to mold the plastic includes projections that extend between the tangs of the commutator and against the notches filled with plastic. The notches filled with plastic and the projections of the mold prevent plastic flash from getting into the slots of the commutator ring when plastic is molded to at least partially encapsulate the magnet wires, armature shaft, and commutator.

[0031] In another aspect of the invention, an armature for an electric motor has a lamination stack on a shaft with a stuffer type commutator mounted on one end of the shaft. The stuffer commutator has a commutator ring divided into a plurality of segments by slots between the segments. Insulative inserts extend part way into each slot from an axial inner end of the commutator ring. Axial inner ends of each segment have slots into which ends of magnet wires are pressed. The lamination stack has slots in which the magnet wires are wound forming coils. The magnet wires, commutator and armature shaft are at least partially encapsulated in plastic, such as by insert molding. The mold used to mold the plastic has a portion that seals around the inner end of the commutator ring above the inserts to prevent plastic flash from getting into the slots between the segments of the commutator ring when the magnet wires, armature shaft and commutator are at least partially encapsulated with plastic.

[0032] In another aspect of the invention, an armature having a lamination stack with slots therein is at least

partially encapsulated by molding thermally conductive plastic around at least parts of it, including in the slots in the lamination stack and around magnet wires wound in the slots. The plastic is molded in the slots so that the slots are cored out leaving recesses in the slots between teeth of the lamination stack. The recesses reduce the amount of plastic molded, enhance heat transfer, and provide slots for receiving projections of tools used in processing the armature to properly locate and orient the armature.

[0033] In another aspect of the invention, a coil structure for a dynamoelectric machine has a lamination stack with a plurality of slots therein. Magnet wires are wound in the slots to form coils. Thermally conductive plastic is molded around the magnet wires to at least partially encapsulate them. Features, such as fins, texturing, or both are formed in the surface of the thermally conductive plastic to enhance heat transfer. In an aspect of the invention, the features are metallized. In an aspect of the invention, the features are pre-formed and insert molded when plastic is molded around the magnet wires. In an aspect of the invention, the features include a metallic finned cap that fits over the end coils of the magnet wires.

[0034] In an aspect of the invention, elements requiring physical robustness, such as the fan, are pre-formed of higher strength material and insert molded when plastic is molded around the armature to encapsulate it in whole or in part.

[0035] In another aspect of the invention, the armature is completely encapsulated with plastic and excess plastic machined off.

[0036] In another aspect of the invention, the armature is a double insulated armature that is encapsulated, in whole or in part, with plastic. In an aspect of the invention, the double insulated armature has an insulative sleeve that is disposed between a shaft of the armature and a lamination stack and between the shaft and a commutator. In an aspect of the invention, the insulative sleeve is disposed between the shaft of the armature and the lamination stack and extends up to the commutator with a seal disposed between the commutator and the insulative sleeve to prevent any plastic from getting into any gap between the insulative sleeve and the commutator when plastic is molded around the armature.

[0037] In another aspect of the invention, the armature is a double insulated armature having a commutator and lamination stack mounted directly on an internal shaft. The internal shaft is coupled to an external pinion and bearing journal by means of an insulated barrier.

[0038] In another aspect of the invention, the plastic molded around the lamination stack, portions of the commutator and the armature shaft helps holds the commutator and lamination stack on the armature shaft and provides for improved torque twist. In a variation of this aspect of the invention, the armature shaft is provided with features, such as one or more flats, that interlock with the plastic molded around them to further improve torque twist.

[0039] In an aspect of the invention, a three plate mold is used to mold the plastic around the armature. In a variation, a two-plate mold is used that has overflow tab cavities into which plastic flows before flashing over the commutator of the armature around which plastic is being molded.

BRIEF DESCRIPTION OF THE DRAWINGS

[0040] The various advantages of the present invention will become apparent to one skilled in the art by reading the following specification and subjoined claims and by referencing the following drawings in which:

[0041] **FIG. 1** is a side elevation view of a prior art armature which incorporates the conventional trickle resin coating and separately manufactured fan secured by adhesives to the armature;

[0042] **FIG. 2** is a schematic view of air flow around end coils of a prior art armature;

[0043] **FIG. 3** is a perspective view of a prior art armature with plastic molded in slots in a lamination stack to form slot liners, at the ends of the lamination stack to form end spiders and around a shaft of the armature;

[0044] **FIG. 4** is a side view of a section of a slot in a lamination stack of a prior art armature with magnet wires held therein by a coil stay;

[0045] **FIG. 5** is a side elevation view of an armature in accordance with an aspect of the invention;

[0046] **FIG. 6** is a side elevation view of an armature in accordance with an aspect of the invention;

[0047] **FIG. 7** is an end view of the armature of **FIG. 6**;

[0048] **FIG. 8** is an end view of a variation of the invention shown in **FIGS. 6 and 7**;

[0049] **FIG. 9** is a coil stay in accordance with an aspect of the invention;

[0050] **FIG. 10** is a view of a section of a slot in a lamination stack with bondable magnet wires therein with the heat activated adhesive of the bondable magnet wires having been activated by the heat of plastic as it is molded in accordance with an aspect of the invention;

[0051] **FIG. 11** is a view of a section of a slot in a lamination stack with magnet wires therein deformed by pressure of plastic molded around them in accordance with an aspect of the invention;

[0052] **FIG. 12** is a view of a section of a slot in a prior art lamination stack with magnet wires therein;

[0053] **FIG. 13** is a view of a section of a slot in a lamination stack with larger size magnet wires therein in accordance with an aspect of the invention;

[0054] **FIG. 14** is a view of a section of a slot in a lamination stack in which magnet wires are compressed by iso-static pressure;

[0055] **FIG. 15** is a view of a section of a stator for an electric motor encapsulated with a thermally conductive plastic in accordance with an aspect of the invention;

[0056] **FIG. 16** is an end view of a section of a stator with a thermally conductive plastic molded in slots in a lamination stack to form slot liners in accordance with an aspect of the invention;

[0057] **FIG. 17** is a perspective view of an armature with a tang type commutator made so that plastic flash is prevented from getting in slots between segments of the commutator in accordance with an aspect of the invention;

[0058] FIG. 18 is a perspective view of a tang type commutator;

[0059] FIG. 19 is a view of a mold, shown representatively, used in making the armature of FIG. 8;

[0060] FIG. 20 is a perspective view of an armature with a stuffer type commutator made so that plastic flash is prevented from getting in slots between segments of the commutator in accordance with an aspect of the invention;

[0061] FIG. 21 is a section view of a partial section of the armature of FIG. 11 taken along the line 21-21 of FIG. 20;

[0062] FIG. 22 is a perspective view of an armature encapsulated with a thermally conductive plastic with features for enhancing heat transfer in accordance with an aspect of the invention;

[0063] FIG. 23 is a perspective view of another armature encapsulated with a thermally conductive plastic with features for enhancing heat transfer in accordance with an aspect of the invention;

[0064] FIG. 24 is a perspective view of an armature encapsulated with a thermally conductive plastic with a necked down region adjacent the commutator in accordance with an aspect of the invention;

[0065] FIG. 25 is a perspective view of an armature having features for heat transfer in accordance with an aspect of the invention;

[0066] FIG. 26 is a side view of features of the armature of FIG. 25 formed in accordance with an aspect of the invention;

[0067] FIG. 27 is a side view of features of the armature of FIG. 25 formed in accordance with an aspect of the invention;

[0068] FIG. 28 is a side section view, broken away, of an armature shaft having features that interlock with plastic molded around them in accordance with an aspect of the invention to improve twist torque;

[0069] FIG. 29 is a perspective view of a double insulated armature in accordance with an aspect of the invention;

[0070] FIG. 30 is a perspective view of another double insulated armature in accordance with an aspect of the invention;

[0071] FIG. 31 is a perspective view of another double insulated armature in accordance with an aspect of the invention;

[0072] FIG. 32 is a side section view of a three plate mold used to encapsulate an armature in accordance with the invention;

[0073] FIG. 33 is a top view of the three plate mold of FIG. 32;

[0074] FIG. 34 is a perspective view of a portion of an armature molded in the three plate mold of FIG. 32 opposite an end of the armature on which a commutator is affixed;

[0075] FIG. 35 is a perspective view of a portion of an armature molded in the three plate mold of FIG. 32 adjacent a commutator;

[0076] FIG. 36 is a portion of a section view of the three plate mold of FIG. 32 and a portion of a lamination stack being encapsulated; and

[0077] FIG. 37 is a representative view of a two-plate mold having overflow tab cavities in accordance with an aspect of the invention.

DETAILED DESCRIPTION OF THE PREFERRED EMBODIMENTS

[0078] Referring now to FIG. 5, a motor 100 in accordance with a preferred embodiment of the present invention is disclosed. The motor 100 includes an armature 102 and a stator 104, the stator being illustrated in highly simplified fashion. The armature 102 incorporates a lamination stack 106 having a plurality of longitudinal slots 108 arranged circumferentially therearound. A plurality of magnet wires 110 are wound in the slots 108 to form a plurality of coil windings having end coils 117. An armature shaft 112 extends coaxially through the lamination stack 106 and has disposed on one end thereof a commutator 114. A thermally conductive plastic 116 is injection molded over the armature 102 so that the plastic flows into and through each of the slots 108. The thermally conductive plastic 116 is applied by placing the armature 102 in a suitable injection molding tool and then injecting the thermally conductive plastic 116 under a suitably high pressure into the molding tool. The thermally conductive plastic 116 preferably at least partially encases the magnet wires 110, and more preferably completely encases the magnet wires to form an excellent means for transferring heat therefrom. The plastic 116 also encases the ends 118 of armature lead wires 119 of the magnet wires 110 which are secured to tangs 120 operably associated with the commutator 114.

[0079] A fan 122 is also integrally formed during the molding of the thermally conductive plastic 116 at one end of the lamination stack 106. Forming the fan 122 as an integral portion of the thermally conductive plastic 116 serves to completely eliminate the manufacturing steps in which a trickle resin is applied to the lamination stack 106 and then a separately formed fan is adhered to the lamination stack 106.

[0080] The molding of the thermally conductive plastic 116 to substantially or completely encase the magnet wires 110 serves to efficiently conduct heat away from the magnet wires. Thus, the thermally conductive plastic 116 even more efficiently serves to secure the magnet wires 110 to the lamination stack 106 to prevent movement of the wires, as well as to secure the magnet wires to the tangs 120 and to improve the conduction of heat from the wires.

[0081] The molding of the fan 122 as an integral portion of the thermally conductive plastic coating 116 also provides a significant manufacturing benefit by removing the cost associated with separately forming such a fan component and then securing the component via an adhesive to the lamination stack 106. This allows the fan 122 to be constructed even more compactly against the lamination stack 106 which allows a motor to be constructed which requires less space than previously developed motors employing independently formed fans.

[0082] Another advantage of having the fan 122 molded from the thermally conductive plastic is that the fan will be

even more resistant to high temperatures which might be encountered during use which stresses the motor 100. With previously developed motors, the fan mounted to the armature thereof is often the first component to fail because of high temperatures encountered during periods of high stress of the motor. The armature 102 of the present invention, with its integrally molded fan 122, is significantly more resistant to failure due to high temperatures.

[0083] The injection molding of a thermally conductive plastic may also more efficiently fill the spaces and voids inbetween the magnet wires 110 extending through the lamination stack slots 108, thus promoting even more efficient cooling of the armature 102 during use.

[0084] In an aspect of the invention, plastic 116 is molded to completely encapsulate all the elements of armature 102, including lamination stack 106 and commutator 114. Thereafter, excess plastic 116 is removed from armature 102, such as by machining, to expose those portions of armature 102 that need to be exposed, such as the surface of commutator 114 and the surface of lamination stack 106.

[0085] Encapsulation also provides enhanced mechanical retention of magnet wires 110 and can be used in lieu of the adhesive typically used to secure the armature lead wires 119. Particularly in high vibration applications, the armature lead wires must be supported, that is, affixed in place. Otherwise, rotation of the armature and vibration of the device in which the motor having the armature is used, such as a power tool, can cause the armature lead wires to vibrate and eventually fatigue and break. Typically, during the trickle resin process described above, a high viscosity adhesive is applied around the armature lead wires up to where they attach to the commutator. This adhesive provides the required support for the armature lead wires.

[0086] Plastic 116 is illustratively molded around armature lead wires 119 when plastic 116 is molded around magnet wires 110. Plastic 116 provides the necessary support for the armature lead wires 119 to prevent them from vibrating when the armature 102 rotates and the device, such as a power tool having a motor using armature 102 vibrates. The armature lead wires 119 can thus be supported by the encapsulation of plastic 116 at little or no additional cost. Moreover, the enhanced mechanical retention provided by encapsulation allows larger gauge magnet wires 110 to be employed on a given size armature, thus increasing the amp rating which can be attained with a motor of given dimensions over a comparably sized motor employing trickle resin sealing of the magnet wires. The larger gauge magnet wires 110 provide better heat transfer and lower heat generation, as well as lower resistance as discussed below.

[0087] The thermally conductive plastic 116 is a illustratively base polymer, such as nylon (nylon 4,6, for example), PPS, PPA, liquid crystal polymer (LCP), or a blend of these, with an appropriate fill percentage of a thermally conductive material such as ceramic (abrasive or lubricious) and, illustratively, an appropriate amount of glass fill for strength. Aluminum oxide is a common type of abrasive ceramic used in thermally conductive plastic and boron nitride is a common type of lubricious ceramic. It should be understood that other thermally conductive materials, metallic or non-metallic, can be used as the fill material, such as aluminum nitride, aluminum or copper. By using a blend for the base polymer, some of advantages of using a more expensive

polymer, such as LCP, can be realized without incurring the cost of using 100% of the more expensive polymer as the base polymer. For example, blending LCP with PPS at a ratio of about 10% LCP to 90% PPS increases moldability and strength compared to pure PPS. Similarly, a small amount of nylon could be used instead of LCP.

[0088] Thermally conductive plastic 116 can illustratively be Konduit® thermoplastic commercially available from LNP Engineering Plastics of Exton, Pa. (presently a General Electric company). In this regard, the thermally conductive plastic 116 can illustratively be Konduit® PDX-TF-212-11 modified to have about ten percent more ceramic fill.

[0089] In an aspect of the invention, a “phase change additive” is added to the material used to encapsulate the armature. As used herein, a “phase change additive” is a material that changes phases, such as from solid to liquid or liquid to gas, at a temperature that is below the temperature at which the material used to encapsulate the armature melts but above ambient temperatures. Preferably, the phase change material is one that changes phases from solid to liquid. The phase change additive would increase the capability of the encapsulation material, such as thermally conductive plastic 116, to handle short term heat spikes that it might not otherwise be able to dissipate quickly enough. When heat spike occurs, the phase change additive changes phase absorbing heat. The phase change additive may illustratively be compounded in small spheres or particles that are added to the plastic used to encapsulate the armature. The capacity of the plastic encapsulating the armature to withstand short heat spikes can then be adjusted by adjusting the amount of phase change additive that is added to it. By using the phase change additive, plastic having lower thermal conductivity, that may be less expensive, can then be used to encapsulate the armature. Use of the phase change additive could also increase the capacity of plastic 116 to withstand the additional heat generated in spikes in more demanding applications. Phase change additives can include paraffins, waxes, hydrated salts and possibly crystalline plastics such as acetal or nylon. An example of a hydrated salt phase change additive is the TH89° C. available from TEAP Energy of Wangar, Perth Western Australia.

[0090] While plastic 116 is illustratively a thermally conductive thermoplastic, other types of materials can be used to encapsulate armature 102, including thermoset materials, as long as the material is electrically non-conductive and has sufficient dielectric strength throughout the operating temperature of armature 102. In this regard, plastic 116 should illustratively have a dielectric strength of at least 250 volts/mil. up to a temperature of 300° C. when armature 102 is used in a power tool. Further, in those aspects of the invention where thermal conductivity of the encapsulating material is not needed, then it need not be thermally conductive. In this regard, while the encapsulation process has been described in the context of injection molding, it should be understood that other processes could be used, such as transfer molding or compression molding. The process used would, of course, need to be suitable for the material being used to encapsulate the armature. For example, transfer molding and compression molding are typically used to mold thermoset materials and injection molding used to mold both thermoplastic and thermoset materials.

[0091] With the armature 102, the thermally conductive plastic 116 may comprise a high temperature nylon or

thermoset material which is further mixed with a suitable non-ferromagnetic material such as ceramic, aluminum or copper, to provide essentially the same density as that of the magnet wires 110. Thus, when each of the lamination stack slots 108 are completely filled with the plastic 116 and the magnet wires 110, the weight of the material filling each slot 108 is essentially the same. Since the weight of the material filling each slot 108 is essentially the same, the need to balance the armature on a balancing machine, after the molding step, is eliminated. Eliminating the balancing step represents a substantial cost savings because no longer is the use of a balancing machine required, as well as the manual labor of setting each of the armatures up on the balancing machine. Instead, once the armatures have cooled after the injection molding process, the armatures can proceed to the commutator turning operation and then directly to the assembly stage where they are assembled with other components to form motors. LNP Engineering Plastics, Inc. is a source of specifically formulated plastics.

[0092] Turning to FIGS. 6 and 7, another aspect of the invention is described. Elements in common with FIG. 5 will be identified with the same reference numerals. When plastic 116 is molded to encapsulate armature 102, features are molded to improve the process of balancing armature 102. These features illustratively include one or more of extra sacrificial material molded at the periphery of end coils 117 (FIG. 2) formed by the windings of magnet wires 110 or molded pockets that may receive balance weights. Utilizing such features in the balancing of armature 102 eliminates the machining of non-homogenous material, eliminates the removal of active iron, permits the thickness of the teeth tops of the teeth of lamination stack 106 to be smaller, and locates the balance planes nearer to the bearing planes allowing truer balancing with less material removed or added.

[0093] Referring specifically to FIG. 6, armature 102 includes one or more balancing rings 124 molded of plastic 116 when plastic 116 is molded to encapsulate armature 102. Illustratively, a balancing ring is molded adjacent each axial side of lamination stack 106 over end coils 117. With specific reference to FIG. 7, during balancing of armature 102, material is removed from one or more of the balancing rings 124 at one or more points 126. Balancing rings 124 are located closer to the bearing planes (not shown) of the motor (not shown) using armature 102 and are inert, that is, do not include active iron. Consequently, removing material from balancing rings 124 does not affect the magnetic characteristics of lamination stack 106 and thus does not adversely affect the performance of the motor in the way that removing iron from lamination stack 106 does.

[0094] In a variation, balancing rings 124 have pockets or cavities 128 formed therein. During balancing of armature 102, weights 130 are inserted and fixed in one or more pockets 128 (FIG. 8) (only one of which is identified by reference numeral 128) of one or more of balancing rings 124 to balance armature 102. Weights 130 are also located nearer the bearing planes and are also inert. In this variation, balancing rings 124 can be made lighter.

[0095] In another aspect of the invention, the mass of plastic 116, the distribution of the molded plastic 116, or both, can be varied to adjust the spinning inertia of armature 102. The mass of plastic 116 can be varied by varying the

amount of plastic 116 used, varying its density, or both. The density of plastic 116 can be varied by, for example, the amount of non-ferromagnetic material mixed with plastic 116. The distribution of the molded plastic 116 controls the spinning inertia of armature 102 by placing more or less plastic 116 around the axis of armature shaft 112, such as closer to or further away from the axis of armature shaft 112.

[0096] Armatures, as is known, have a natural frequency at which they resonate, commonly referred to as the resonant frequency. This frequency is a function of the geometry and stiffness of the armature. In another aspect of the invention, the natural or resonant frequency of armature 102 can be adjusted by varying the geometry, physical and/or mechanical (physical) properties of plastic 116. Varying the geometry, physical and/or mechanical (such as its tensile or flexural modulus) properties of plastic 116 varies the stiffness of armature 102. For example, increasing the physical (such as density, hardness, or both) of plastic 116 provides vibration damping for armature 102. Also, increasing the stiffness of armature 102 increases its critical speed, that is, the rotational speed at which armature 102 resonates. The critical speed of the armature is often the limiting factor of how fast a motor can spin in that its speed must be kept below the critical speed. By increasing the critical speed, the maximum speed at which the motor can be run is increased, which increases the output power that the motor can provide. For example, applicants have found that using an encapsulated armature in a small angle grinder (a DeWalt DW802 SAG), the critical speed of the armature was increased about 11.5%, that is, from 39,300 RPM to 43,800 RPM.

[0097] Plastic 116 also provides structural reinforcement around armature shaft 112 to reduce and/or control vibration and flexing of armature shaft 112. The geometry and mechanical properties of plastic 116 can be adjusted to obtain the desired vibration and/or flex reduction/control of armature shaft 112.

[0098] Bondable wire is typically used to adhere wires, such as magnet wires in a field, together without the addition of glue or varnish in a secondary operation, such as the above described trickle resin operation. Bondable wire has a layer of material thereon that becomes sufficiently viscous when hot that it adheres together adjacent wires in the bundle of wires forming the coil and then hardens to bond the wires together. This forms a coil that is mechanically solid and also has improved thermal properties due to the reduction of air pockets between wires. One type of bondable wire has a layer of heat activated adhesive thereon. A type of this bondable wire having a layer of heat activated adhesive thereon is available under the trade name BOND-EZE from Phelps Dodge of Fort Wayne, Ind.

[0099] With reference to the embodiment described in FIG. 5, when the thermally conductive plastic 116 is molded around magnet wires 110, thermally conductive plastic 116 may not fill all the interstitial voids between the magnet wires 110. In another aspect of the invention, magnet wires 110 can be bondable wires that are then encapsulated in a hot encapsulation material. In an embodiment, the bondable wire is BONDEZE wire. The heat of the hot encapsulation material, such as injection molded thermally conductive plastic 116, activates the layer of heat activated adhesive on magnet wires 110, bonding magnet wires 110 together.

[0100] FIG. 10 shows slot 108 having magnet wires 110 encapsulated in thermally conductive plastic 116 where the

heat of the thermally conductive plastic as it was molded around magnet wires 110 activated heat activated adhesive 111 bonded magnet wires 110 together. This forms a mechanically solid coil inside thermally conductive plastic 116. This reduces or prevents movement of the coil and improves thermal transfer, as described above. This aspect of the invention further contributes to the elimination of the need for the trickle resin process of bonding the magnet wires together. Further, the heat generated during the molding process activates the heat activated adhesive obviating the need to separately activate the heat activated adhesive 111, such as by baking in an oven or passing a current through magnet wires 110 to heat them to activate the heat activated adhesive. For this aspect of the invention, the temperature of the encapsulation material being used just needs to exceed the temperature required to activate the heat activated adhesive on the magnet wire 110.

[0101] Turning to FIG. 11, another aspect of this invention is described. FIG. 11 shows magnet wires 110 in one of lamination slots 108 encapsulated by thermally conductive plastic 116. By setting the pressure at which the plastic 116 is molded around magnet wires 110 at a sufficiently high level, magnet wires 110 can be at least partially deformed into polygonal shapes from their original round shape. This increases the surface area contact between magnet wires 110 and thus improves thermal conductivity from the bottom magnet wires 110 through the other magnet wires 110 into thermally conductive plastic 116. It is thought that the foregoing is advantageous when the diameter of magnet wires 110 or the fill pattern of magnet wires 110 (such as how close they are compacted together) prevents each magnet wire 110 from being completely surrounded by thermally conductive plastic 116.

[0102] In another aspect of this invention, the pressure at which the plastic 116 is molded around magnet wires 110 is set at a sufficiently high level to compact the wires together, providing for an increased fill rate in lamination slots 108. That is, a higher percentage of the volume of lamination slots 108 is filled with magnet wires. In this regard, magnet wires 110 may be initially wound in lamination slots 108 so that they extend close to or even beyond an outer surface of lamination stack 106. The pressure of the plastic 116 as it is molded then compacts the magnet wires 110 together and forces the compacted magnet wires 110 into slots 108.

[0103] In an aspect of the invention, coil stays 19 (FIG. 4A) are made of thermally conductive plastic that is melted or wetted during molding of plastic 116.

[0104] In an aspect of the invention, plastic 116 replaces coil stays 19 of prior art armature 10, and holds magnet wires 110 in place when it hardens.

[0105] In an aspect of the invention, coil stays 19' (FIG. 4B) have holes 142 therein. During molding of plastic 116, plastic 116 flows through and bypasses coil stays 19'. Plastic 116 is illustratively a thermally conductive plastic, as described, and molding it through holes 142 in coil stays 19' allows more heat to flow toward the surface of the lamination stack, such as lamination stack 106 (FIG. 5).

[0106] With reference to FIGS. 12 and 13, a larger size magnet wire is used to wind magnet wires 110 (FIG. 13) than to wind magnet wires 16 (FIG. 12). Slots 14 in FIG. 12 and slots 108 in FIG. 13 are the same size. In the

embodiment of FIG. 13, plastic 116 is molded at pressure around magnet wires 110 compacting them together in slots 108 allowing slots 108 to accommodate the magnet wires 110 wound with the larger size magnet wire. Magnet wires 110 can thus be a larger size magnet wire compared to magnet wires 16 of FIG. 12. Thus, magnet wires 110 wound in slots 108 of a given size, which dictates in large part the size of the lamination stack 106 having slots 108, can be a larger size magnet wire. This results in the motor having the magnet wires 110 wound with the larger size magnet wire having increased power compared with the motor having the magnet wires 16 wound with the smaller size magnet wire, yet having the same size lamination stack. Thus, a higher output motor having a given physical size is achieved.

[0107] In an alternative aspect of the foregoing, the magnet wires 110 are wound in slots 108 and then compacted, such as by the application of iso-static pressure, before armature 102 is encapsulated. For example, armature 102, after magnet wires 110 have been wound in slots 108 but before armature 102 is encapsulated, is placed in a properly shaped cavity of a fluid bladder, shown schematically as fluid bladder 144 in FIG. 14. The pressure of the fluid in fluid bladder 144 is increased, forcing magnet wires 110 deeper into slots 108. Armature 102 is then encapsulated, as described above, with the plastic 116 encapsulating armature 102 holding magnet wires 110 in slots 108 after plastic 116 hardens. In a variation of the above, magnet wires 110 are made of bondable wire, as described above, which are thermally cured during the compaction of magnet wires 110 by fluid bladder 144.

[0108] With reference to the prior art armature shown in FIG. 3, another aspect of the invention is described. In this aspect of the invention, prior art armature 40 is modified by making it using thermally conductive plastic as the plastic in which armature shaft 44 and lamination stack 42 are insert molded. The thermally conductive plastic forms end spiders 48 and slot liners 50 in the manner described above and is also molded between shaft 44 and lamination stack 42 of armature 40 to electrically insulate shaft 44 from lamination stack 42. In this regard, the thermally conductive plastic is selected to have adequate thermal conductivity and dielectric strength or electrically insulative properties. The thermally conductive plastic can illustratively be Konduit.®

[0109] In armatures encapsulated in plastic it is important that plastic flash be prevented from entering the slots in the commutator ring when the plastic is molded. If flash enters the slots in the commutator ring, it may project outwardly from the slots and create a bump or ridge that the brushes will contact when the armature rotates.

[0110] An aspect of the invention described with reference to FIGS. 17-18 prevents flash from getting into the slots of a tang type commutator ring. An armature 300 has a shaft 302 and a lamination stack 304. A commutator 306 is mounted on one end of shaft 302. Commutator 306 includes a copper commutator ring 308, divided into a plurality of segments 310, around a cylindrical core 312, with slots 314 between adjacent segments 310. Cylindrical core 312 is made of an electrically insulative material, such as phenolic.

[0111] Each commutator segment 310 has a tang 318 extending from an axial inner end 326. Tangs 318 are electrically connected to ends of the magnet wires (such as magnet wires 110 of FIG. 5) in known fashion.

[0112] To form commutator 306, notches 322 are cut around axial inner end of commutator ring 308. Notches 322 are positioned so that they are below the track followed by the brushes (not shown) of the motor in which armature 300 is used and to be at the axial inner ends of slots 314 when they are cut. Plastic 316 is next molded in commutator ring 308, such as by insert molding commutator ring 308, to form cylindrical core 312 therein. Plastic 316 is illustratively phenolic. Plastic 316 fills notches 322.

[0113] Slots 314 are then cut in commutator ring 308. Slots 314 extend radially through commutator ring 308 and run axially from an axial outer end 324 of commutator ring 308 part way into the plastic 316 that filled notches 322.

[0114] Commutator 306, shaft 302 and lamination stack 304 are next assembled together and the ends of the magnet wires of armature 300 are connected to tangs 318 in conventional fashion. Shaft 302, with commutator 306, and lamination stack 304 are then placed in a mold 400 (shown representatively in FIG. 19) and plastic 328 (FIG. 17) molded around them to form armature 300 in similar manner to that described above with respect to FIG. 5 with the following differences. Mold 400 is provided with projections 402 that fit between tangs 318 over notches 322. Projections 402 prevent plastic 328 from flowing into slots 314 from the sides of slots 314 by providing thin wall flow regions that allow the plastic to freeze off quicker. The plastic 316 that filled notches 322 when cylindrical core 312 was molded prevents plastic 328 from flowing axially into slots 314 from the inner ends 320 of slots 314.

[0115] Turning to FIGS. 20 and 21, another aspect of the invention for preventing flash from getting into the commutator slots in a stuffer type commutator is described. In a stuffer type commutator, inner ends of the segments of the commutator ring have slots into which ends of the magnet wires are pressed.

[0116] An armature 501 has a shaft 503 on which commutator 500, which is a stuffer type commutator, is mounted in known fashion. As is known, a stuffer type commutator, such as commutator 500, has a commutator ring 516 with slots 504 between segments 514. Inserts 502 extend part way into slots 504 from an inner end 506 of commutator ring 516. Inserts 502 are illustratively made of mica or plastic. Ends of magnet wires 510 are pressed into slots (not shown) in ends 508 of segments 514 of commutator ring 516.

[0117] Armature 501 is encapsulated by molding plastic 512 around its shaft 503 and lamination stack 505 in a manner similar to that described above. The tool or mold used in molding plastic 512 is configured so that it seals around inner end 506 of commutator ring 516 where inserts 502 are located in slots 504 of commutator ring 516, such as 518. Illustratively, ends 520 of inserts 502 extend distally beyond the point 518 where the tool seals around inner end 506 of commutator 500 and are thus disposed underneath the tool. When plastic 512 is molded, plastic 512 is molded around inner end 506 of commutator ring 516 only where inserts 502 are in slots 504 and plastic 512 is thereby prevented from flowing into slots 504.

[0118] Turning to FIG. 22, another aspect of the invention is described. An armature 600 is encapsulated by molding thermally conductive plastic 602 around its shaft 604 and lamination stack 606. The tool or mold used to mold the

plastic 602 is configured so that the slots 608 between teeth 610 of lamination stack 606 are cored out. As used herein, cored out means that the plastic 602 is not molded to top surfaces 611 of the lamination teeth 610, so that the plastic molded in the slots 608 is recessed from the top surfaces of the lamination teeth 610, forming recesses 612, through which cooling air can flow. By coring out slots 608, heat transfer is improved, less plastic is used and recesses 612 can be used by tools in subsequent armature manufacturing operations, such as for orienting, locating and/or indexing armature 600. In this regard, the tool used in molding plastic 602 can have features, such as blades, that fit within slots 608 to form recesses 612 and these blades can also hold armature 600 in the correct radial position during molding. The surface of plastic 602 can be textured to increase the surface area of the plastic and/or cause turbulence, thus increasing heat transfer, without taking up additional space. The texturing can take the form of a pattern 613, such as a diamonds, squares, circles, bumps, dimples, and the like. Illustratively, the texturing is done on the surface of plastic 602 at an end of lamination stack 606 opposite an end of lamination stack 606 where fan 122 is formed.

[0119] FIG. 23 shows a variation of the just discussed aspect of the invention. The same reference numbers are used to identify like elements. In FIG. 23, when plastic 602 is molded to encapsulate armature 600, integral features are formed, such as fins 614, that increase surface area and create turbulence. FIGS. 34 and 35 show differently shaped fins 614, only two of which are identified by reference numeral 614 therein.

[0120] FIG. 24 shows another variation of the just discussed aspect of the invention. The same reference numbers are used to identify like elements. In FIG. 24, plastic 602 is molded so that a necked down region 616 is formed between the lamination stack 606 of armature 600 and commutator 618, which reduces the amount of plastic required. The surface of plastic 602 is textured as described above to enhance heat transfer, or features such as fins 614 (FIG. 24) formed thereon.

[0121] In addition to or in lieu of forming the features such as recesses 612, texture pattern 613, fins 614 and necked down region 616 during molding plastic 602, they can be formed in secondary operations such as milling, turning or grinding. However, forming these features during molding plastic 602 allows less plastic to be used than if the plastic 602 is removed from armature 600 during a secondary operation to form the feature.

[0122] Turning to FIGS. 25-27, another aspect of the invention is described that provides better thermal conductivity than that provided by using thermally conductive plastics, which typically have a thermal conductivity in the 1 to 10 W/m-K. Features 700 are insert molded onto armature 102 during the molding of plastic 116 or features 700 are molded from plastic 116 and then metallized. Features 700 may illustratively be a finned metal or ceramic end coil cover 700' that is insert molded onto armature 102 during the molding of plastic 116. Plastic 116, which is illustratively thermally conductive plastic as described above, is molded to form a thin layer between end coils 117 of magnet wires 110 and the finned end coil cover 700'. With specific reference to FIG. 25, finned end coil cover 700' also includes a fan 702 shown in phantom in FIG. 25 affixed

thereto or formed integrally therewith. In a variation, finned end coil cover **700'** is molded from a thermally conductive plastic having a higher thermal conductivity than plastic **116**. With specific reference to **FIGS. 25 and 27**, features **700**, such as fins, posts, or blades which are designated as **700"** in **FIG. 27**, are molded out plastic **116** when plastic **116** is molded to encapsulate armature **102**. End domes **704** including the features **700"** are then covered with a thin metallic layer **706**, such as by metallizing them with a vapor deposition or other metallization process.

[**0123**] In another aspect of the invention, the plastic, such as plastic **116** (**FIG. 5**) molded around lamination stack **106**, portions of commutator **114** and armature shaft **112** helps hold lamination stack **106** and commutator **114** on armature shaft **112** and improves twist torque. Twist torque, as that term is commonly understood, is the amount of torque differential between armature shaft **112** and lamination stack **106** or commutator **114** that can be withstood before armature shaft **112** turns within lamination stack **106** or commutator **114**. In a variation of this aspect of the invention, an armature shaft **112a** (**FIG. 28**) is provided with features that interlock with the plastic **116** molded around them to further improve twist torque. These features can include one or more flats **710**, projections **712**, or other features that interlock with the plastic **116** when plastic **116** is molded around them.

[**0124**] Turning to **FIGS. 29 and 30**, another aspect of the invention is described where the armature is a double insulated armature. Elements in **FIGS. 29 and 30** common to the elements in **FIG. 5** are identified with the same reference numerals.

[**0125**] **FIG. 29** shows a double insulated armature **800** having a protecting insulating sleeve **802** disposed around shaft **112**. Commutator **114** and lamination stack **106** are mounted on shaft **112** with insulating sleeve **802** disposed between lamination stack **106** and shaft **112** and between commutator **114** and shaft **112**. Armature **800** includes magnet wires **110** wound in slots **108** of lamination stack **106**. Plastic **116** is molded over the armature **800** so that the plastic **116** flows into and through each of the slots **108** and around end coils **117** of magnet wires **110**.

[**0126**] Armature **800** is illustratively formed by first placing insulating sleeve **802** on shaft **112**. It should be understood that insulating sleeve can be made of other materials, such as high-temperature, glass reinforced thermosetting resin. It could also be preformed and then placed on shaft **112**. Shaft **112** with insulating sleeve **802** thereon is then in situ molded with lamination stack **106**, such as by molding plastic **116**. Plastic **116** is electrically insulative and forms the functional insulation layer on the axial ends and in the slots **108** of armature **800**. In this regard, the mold is made so that plastic **116** is molded in slots **108** so as to coat the walls of lamination stack **106** leaving the remainder of slots **108** open, as well as to form the end spiders around the axial ends of lamination stack **106**, such as described above with reference to **FIG. 3**. Magnet wires **110** are then wound in slots **108** and ends of magnet wires **110** (**FIG. 5**) affixed to commutator **114**, which has been placed on shaft **112** over insulating sleeve **802**. The resulting assembly is then placed in a suitable molding tool and plastic **116** molded around the desired elements of armature **800**. Plastic **116** is illustratively a thermally conductive plastic as described above and

it is injection molded around the elements of armature **800**. Plastic **116** is also illustratively electrically insulative.

[**0127**] In double insulated armatures, it is important that the protective insulation barrier be complete and uninterrupted. If the insulated sleeve is bridged by the functional insulation, particularly if the functional insulation is a thermally conductive resin, there is the possibility of excessive leakage currents during overly abusive loads as the thermally conductive resin's electrical properties, e.g., dielectric strength and bulk resistivity, deteriorates at nearly destructive temperatures.

[**0128**] An uninterrupted barrier is easy to achieve when the lamination stack, windings and commutator are all separated from the shaft by the insulative sleeve, such as when the insulative sleeve runs the entire length of the shaft such as shown with respect to sleeve **802** and shaft **112** in **FIG. 29**. However, design constraints sometimes do not allow a sufficient radial distance for the commutator to be placed on the insulative sleeve and must be placed directly on the shaft without the insulative sleeve therebetween. In these cases, the commutator must be constructed so that its insulation barrier provides reinforced insulation spacings and properties.

[**0129**] Turning to **FIG. 30**, a double insulated armature **810** with commutator **114** placed directly on shaft **112** without an insulative sleeve between it and shaft **112** is shown. Insulative sleeve **812** is disposed on shaft **112** between lamination stack **106** and shaft **112** and extends axially up to commutator **114**. Any gap between the end of insulative sleeve **812** and commutator **114** is sealed by high temperature seal **814** and prevents plastic **116**, which is illustratively thermally conductive plastic as discussed, from flowing into any gap between the end of insulative sleeve **812** and commutator **114** when plastic **116** is molded to encapsulate armature **810**. Instead of seal **814**, labyrinths, dams or high temperature gaskets can be used.

[**0130**] Turning to **FIG. 31**, an alternative embodiment of a double insulated, encapsulated armature is shown. Armature **900** has lamination stack **106** and commutator **114** directly mounted on an internal shaft **902** and is encapsulated with plastic **116**, which is illustratively thermally conductive plastic as discussed. Internal shaft **902** is coupled to an external pinion **904** and bearing journal **906** that has a cylindrical cavity **908** lined with a layer of electrical insulation **910**. While **FIG. 31** shows internal shaft **902** received in insulated cylindrical cavity **908**, it should be understood that bearing journal **906** could be reversed and external pinion **904** received in insulated cylindrical cavity **908**. The foregoing embodiment shown in **FIG. 31** provides a double-insulated armature where the protecting insulation is distinct and discrete from the heat generating portions of the armature.

[**0131**] Turning to **FIGS. 32-35**, a three-plate mold **1000** used for molding plastic **116** to encapsulate armature **102** is shown. Elements in **FIGS. 32-35** that are common with elements in **FIG. 5** will be identified with the same reference numerals. Three plate mold **1000** is shown in a molding machine **1002**, which is illustratively a plastic injection molding machine, with armature **102** therein. Three plate mold **1000** includes core plate **1004**, cavity plate **1006** and runner plate **1008**. Core plate **1004** has a generally can shaped cavity **1005** in which armature **102** is received,

commutator **114** first. That is, armature **102** is received in core plate **1004** with commutator **114** adjacent an end or bottom (as oriented in **FIG. 32**) **1010** of core plate **1004**. Core plate **1004** may include a pressure transducer port **1012** in communication with a pressure transducer **1014** therein.

[0132] Runner plate **1008** has a hole **1024** therein through which armature shaft **112** extends when armature **102** is in mold **1000**. In runner plate **1008**, a runner **1017** splits into two semicircular runners **1018** (shown in dashed lines in **FIG. 33**) around hole **1024** in which shaft **112** of armature **102** is received when armature **102** is in mold **1000**. Semicircular runners **1018** form a ring runner **1019**. The runner **1017** extends to an exit **1021** of a hot sprue **1022**. Cavity plate **1006** includes drop passages **1016** extending from ring runner **1019** in runner plate **1008** to gates **1020**. Gates **1020** are preferably located so that they are between slots **108** of armature **102** when armature **102** is in mold **1000** and in spaced relation to ends **107** of slots **108**. With specific reference to **FIG. 34**, a gate **1020** is located between and above adjacent slots **108** of lamination stack **106**. Consequently, each gate **1020** feeds two slots **108** of lamination stack **106**.

[0133] With specific reference to **FIG. 36**, core plate **1004** may have keys **1026** that engage slots **108** in lamination stack **106** of armature **102** to locate armature **102** in mold **1000** so that gates **1020** are disposed between adjacent slots **108** of lamination stack **106**. Illustratively, each slot **108** has one of keys **1026** projecting into it, which key illustratively extends the length of that slot **108**. The keys **1026** are preferably sized to provide thin wall flow regions before the outside diameter of lamination stack **106**, minimizing the chance of flashing to the outside diameter of lamination stack **106**. Also, locating gates **1020** between slots **108** may prevent plastic **116** from “jetting” down the slots **108** before filling thin wall areas above the coils of magnet wires **110**. This is important with most thermally conductive plastics in that once the melt front stops, the thermally conductive plastic quickly freezes and won't flow again. Thus, if the plastic **116** “jets” down the slots, it may not be possible to pack out the thin wall areas afterwards.

[0134] In operation, armature **102** (in its pre-encapsulated state) is placed in core plate **1004** of mold **1000**, commutator **114** first. Cavity plate **1006** is then closed over the other end of armature **102** and runner plate **1008** closed over cavity plate **1006**. Plastic **116** is then injected into mold **1000**, flowing from hot sprue **1022** through runner **1017** into semicircular runners **1018** of ring runner **1019**, through drop passages **1016** in cavity plate **1006**, through gates **1020** and around armature **102** in mold **1000**. It should be understood that other gate configurations can be used, such as ring and flash gates on three-plate molds and tab gates on two-plate molds.

[0135] The pressure in the cavity of mold **1000** is monitored using pressure transducer **1014**. Port **1012** in core plate **1004** is illustratively positioned toward bottom **1010** of core plate **1004** so that the pressure in the cavity of mold **1000** is monitored generally at the opposite ends of where gates **1020** are located. When the pressure in the cavity of mold **1000** reaches a predetermined level, as sensed by pressure transducer **1014**, the injection molding machine is switched

from its fill stage to its packing stage. As is known, during the fill stage, the shot pressure is high. Once the mold cavity is nearly filled, the injection molding machine is switched to the packing stage where the shot pressure is backed off to a lower level. The shot pressure is then maintained at this lower level until the plastic hardens, typically determined by waiting a set period of time. By using the pressure in the cavity of mold **1000** to determine when to switch from the fill stage to the packaging stage, as opposed to constant molding parameter such as shot size, injection time, etc., effects of variations in the material properties of the plastic can be reduced.

[0136] Illustratively, this predetermined pressure is set at a level that indicates that the cavity of mold **1000** is nearly filled with plastic **116**. A technique known as “scientific molding” is illustratively used to control injection molding machine **1002** to minimize the chance of flashing at commutator **114**. One such scientific molding technique is the DECOUPLED MOLDINGSM technique available from RJG Associates, Inc. of Traverse City, Mich.

[0137] Pressure transducer **1014** could also be used to determine if a part is molded correctly. That is, a determination is made whether the pressure in the cavity of mold **1000** reached a sufficient level so that the cavity of mold **1000** was completely filled. If not, the part is rejected. In this regard a good/bad indicator may be driven based on the monitored pressure in the cavity of mold **1000** to alert the operator of injection molding machine **1002** whether the molded part is good or bad. Injection molding machine **1002** may also be configured to automatically accept or reject a part based on the monitored pressure.

[0138] Referring to **FIG. 37**, a mold **1100**, which is illustratively a two-plate mold, is shown schematically. Two plate mold **1100** is formed to have overflow tab cavities **1102** to allow overflow tabs **1104** to be formed when plastic **116** is molded to encapsulate armature **102**. Illustratively, overflow tabs are formed adjacent commutator **114**. Overflows tabs **1104** help control molding pressure at commutator **114**, helping to prevent flash while still providing a complete fill and encapsulating of magnet wires **110** with plastic **116**. Gates **1106** extend from cavity **1108** of mold **1100** to each overflow tab cavity **1102**. Gates **1106** are sized so that as molding pressure builds up in cavity **1108**, the plastic **116** flows into the overflow tab cavities **1102** before flashing over commutator **114**. Because most thermally conductive plastics set up quickly, delaying the melt front at the commutator **114** enables the plastic **116** to freeze off in the area of commutator **114** so that when the overflow tab cavities **1102** are full and the pressure in cavity **1108** continues to build up, the risk of flash over commutator **114** is minimized or eliminated. The de-gating process would illustratively accommodate the overflow tabs **1104** as additional runners that are removed during the de-gating process so that no additional cycle time results. It should be understood that overflow tabs **1104** can be any shape or size sufficient to delay the build-up of pressure in mold **1100**.

[0139] In another aspect of the invention, features that may illustratively be molded when the armature, such as armature **102**, is encapsulated with plastic, such as plastic **116**, but that must be physically robust, can be pre-formed, such as by pre-molding them out of a sufficiently strong plastic, and then insert molded when the armature is encap-

sulated. This allows the use of a thermally conductive plastic that does not provide the physical robustness required by these features but has other properties, such as better thermal conductivity, than the plastics that provide the physical robustness required by these features. With reference to **FIG. 5**, fan **122** is an example of a feature that requires a certain degree of physical robustness. Fan **122** can be pre-formed, such as by pre-molding it if a plastic that provides the necessary physical robustness and then insert molded to attach it to armature **102** when armature **102** is encapsulated with plastic **116**. Plastic **116** can then be selected from plastics having the optimum characteristics for encapsulating armature **102** even if such plastics do not provide the physical robustness needed by fan **122**. This would permit a lower cost material to be used for plastic **116** than would be the case if plastic **116** is also used to mold fan **122** in the manner discussed above. Use of the higher cost plastic that provides more robust physical characteristics would then be limited to those features that require the greater degree of physical robustness. This would also permit a plastic having high thermal conductivity but that is structurally weak or has little impact strength to be used for plastic **116** with fan **122** being pre-formed of the higher strength plastic.

[0140] While foregoing aspects of the invention have been described with reference to an armature of an electric motor, many of the principles are applicable to other coil structures used in dynamoelectric machines, such as stators for electric motors and coil structures for generators and alternators. **FIG. 15** shows a stator **150** for an electric motor, such as motor **100** (**FIG. 5**). Stator **150** includes a lamination stack **151** having a plurality of slots **152** therein. Magnet wires **154** are wound in slots **152** to form coils **156**. Thermally conductive plastic **158** is molded at least partially around magnet wires **154** and preferably completely encapsulates magnet wires **154**. Similarly, the surface of plastic **158** can be molded with features, such as fins, or textured to enhance heat transfer, the features metallized, or features pre-formed and insert molded when plastic is molded around magnet wires **154**.

[0141] **FIG. 16** illustrates the application of the invention described with respect to **FIG. 3** to a stator. A stator **250** has a lamination stack **252**. Lamination stack **252** has a plurality of slots **254** lined with slot liners **260** made of thermally conductive plastic. Magnet wires **256** are wound in slots **254** forming coils **258**. Thermally conductive plastic is molded in slots **254** to form slot liners **260**, which electrically insulate magnet wires **256** from lamination stack **252** as well as enhance heat transfer from magnet wires **256**. In this regard, the thermally conductive plastic is selected to have a desired thermal conductivity and dielectric strength or electrically insulative properties.

[0142] The description of the invention is merely exemplary in nature and, thus, variations that do not depart from the gist of the invention are intended to be within the scope of the invention. Such variations are not to be regarded as a departure from the spirit and scope of the invention.

What is claimed is:

1. A method of manufacturing an armature for an electric motor, comprising:
 - placing a commutator and a lamination stack on an armature shaft;

- winding magnet wire in slots in the lamination stacks to form coils;
 - attaching ends of the magnet wire to the commutator; and
 - molding plastic around the magnet wire and around the shaft of the armature to stiffen the armature and thereby increase the critical speed of the armature.
2. The method of claim 1 wherein the plastic is thermally conductive plastic.
 3. The method of claim 1 wherein molding the plastic around the magnet wire and around the shaft of the armature includes molding the plastic to increase the critical speed of the armature at least ten percent.
 4. The method of claim 1 including adjusting one or more of a geometry of the molded plastic, a physical property of the molded plastic and a mechanical property of the molded plastic to increase the stiffness of the armature.
 5. The method of claim 4 including increasing the physical property of the molded plastic to provide vibration dampening for the armature.
 6. The method of claim 5 wherein the physical property of the molded plastic is one or more of density and hardness.
 7. An electric motor, comprising:

- a stator;
- an armature disposed in the stator, the armature including;
- a lamination stack having slots therein;
- a plurality of magnet wires wound in the slots of the lamination stack;
- an armature shaft extending coaxially through the lamination stack stiffened with plastic molded around the magnet wires and armature shaft so that with the plastic stiffening the shaft of the armature the armature has a higher critical speed than without the plastic stiffening the shaft and
- a commutator disposed on the armature shaft to which ends of the magnet wires are electrically coupled.

8. The electric motor of claim 7 wherein the critical speed of the armature having its shaft stiffened by the plastic is at least ten percent higher than the critical speed of the armature without its shaft stiffened by the plastic.
9. The electric motor of claim 8 wherein the plastic is thermally conductive plastic.
10. The electric motor of claim 7 wherein the molded plastic has one or more of a geometry, a physical property and a mechanical property adjusted to increase the stiffness of the armature.
11. The electric motor of claim 10 wherein the molded plastic has a physical property increased to provide vibration dampening for the armature.
12. The electric motor of claim 11 wherein the physical property of the molded plastic is one or more of density and hardness.

13. A method for forming a power tool, comprising:
 - forming an armature by
 - placing a commutator and a lamination stack on an armature shaft;
 - winding magnet wire in slots in the lamination stacks to form coils;

attaching ends of the magnet wire to the commutator;
and

molding plastic around the magnet wire and around the shaft of the armature to stiffen the armature and thereby increase the critical speed of the armature;

disposing the armature in a stator to form an electric motor; and

disposing the electric motor in the power tool.

14. The method of claim 13 wherein the plastic is thermally conductive plastic.

15. The method of claim 13 wherein molding the plastic around the magnet wire and around the shaft of the armature includes molding the plastic to increase the critical speed of the armature at least ten percent.

16. A method of manufacturing an armature for an electric motor, comprising:

placing a commutator and a lamination stack on an armature shaft;

winding magnet wire in slots in the lamination stacks to form coils;

attaching ends of the magnet wire to the commutator;

molding plastic around the magnet wire and around the shaft of the armature at ends of the lamination stack; and

adjusting at least one of a resonant frequency and critical speed of the armature by adjusting one or more of a geometry of the plastic molded, a physical property of the plastic and a mechanical property of the plastic.

17. The method of claim 17 wherein adjusting the geometry of the plastic includes molding a sufficient amount of the plastic around the armature shaft to reduce vibration and flexing of the armature shaft.

18. The method of claim 16 wherein adjusting the mechanical properties of the plastic includes adjusting at least one of its tensile modulus and flexural modulus and adjusting the physical properties of the plastic includes adjusting at least one of its density and hardness.

19. The method of claim 16 wherein molding the plastic increases vibration damping of the armature shaft.

20. The method of claim 16 wherein the plastic is thermally conductive plastic.

21. An electric motor, comprising:

a stator; and

an armature disposed in the stator, the armature including

a lamination stack having slots therein;

a plurality of magnet wires wound in the slots of the lamination stack;

an armature shaft extending coaxially through the lamination stack and having plastic molded around it in a sufficient amount to reduce vibration and flexing of the armature shaft; and

a commutator disposed on the armature shaft to which ends of the magnet wires are electrically coupled.

* * * * *