



US 20020112752A1

(19) **United States**

(12) **Patent Application Publication**  
**Blakney**

(10) **Pub. No.: US 2002/0112752 A1**

(43) **Pub. Date: Aug. 22, 2002**

(54) **CANOPY FRAME WITH OUTDOOR CANOPIES FOR CHAIR**

(76) Inventor: **Carol Jean Blakney, Muncie, IN (US)**

Correspondence Address:  
**Carol Jean Blakney**  
**3700 West Ewing Drive**  
**Muncie, IN 47302 (US)**

(21) Appl. No.: **09/790,181**

(22) Filed: **Feb. 22, 2001**

**Publication Classification**

(51) **Int. Cl.<sup>7</sup> ..... E04H 15/04; E04H 15/02**

(52) **U.S. Cl. .... 135/96**

(57) **ABSTRACT**

The Blakney "Canopy Frame with Outdoor Canopies for Chair" was invented to provide a portable and aesthetic

solution for a number of problems that confront people when they sit outdoors. Many ways have been devised to attach shades to chairs or to add seats to blinds, often with very complex mechanisms. This invention minimizes mechanism and expands function. This "Canopy Frame for Chair" consists of three integral parts: canopies, frame, and chair-bag. A set of interchangeable canopies includes a sunshade, a mosquito net, and a photography or changing blind. The collapsible canopy frame, over which canopies can be draped, can be easily mounted and removed from a chair. The chair bag not only serves as the mounting system for attaching the canopy frame to a chair, but also has a pouch to store the canopies. The invention is lightweight, streamlined and completely portable even collapsing neatly with a folding chair. The Blakney "Canopy Frame with Outdoor Canopies for Chair" provides easy access to a number of canopy options, and it can be quite beautiful when the fabrics are color coordinated with the chair they are draped over. The invention is unique in its multipurpose function, aesthetic possibility and simplicity.

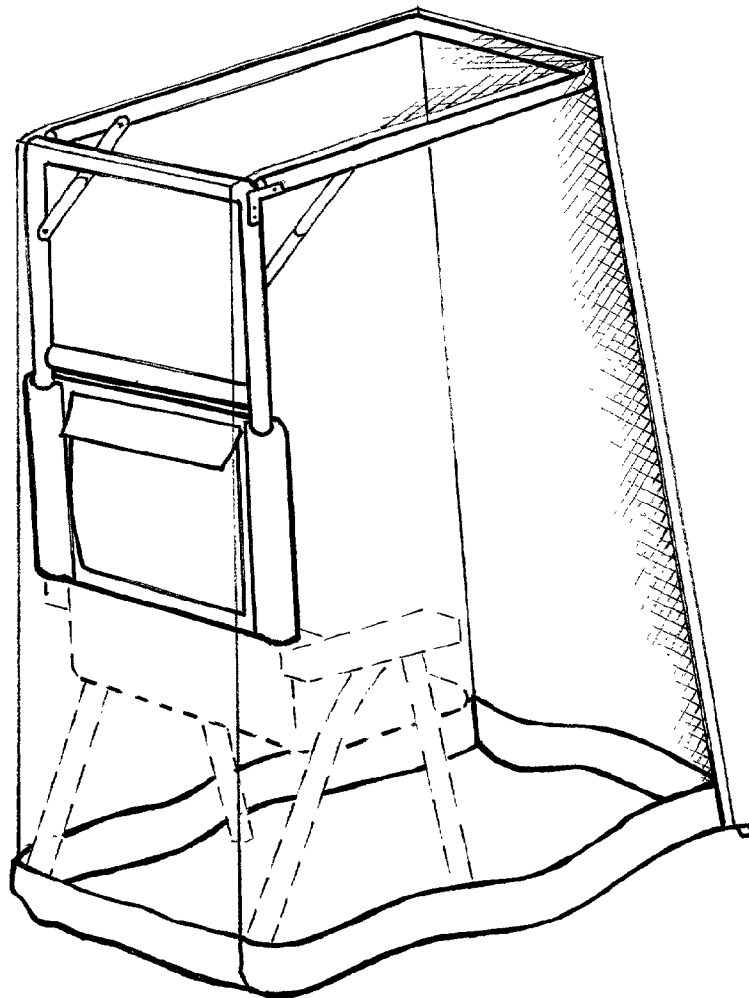

FIG. 1

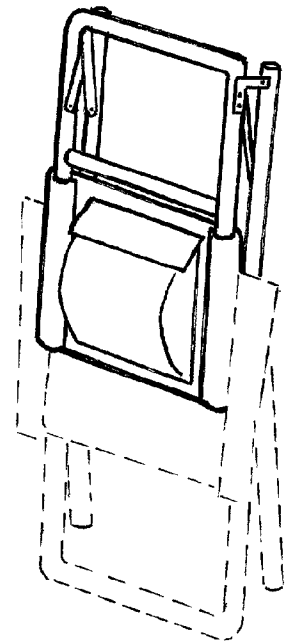
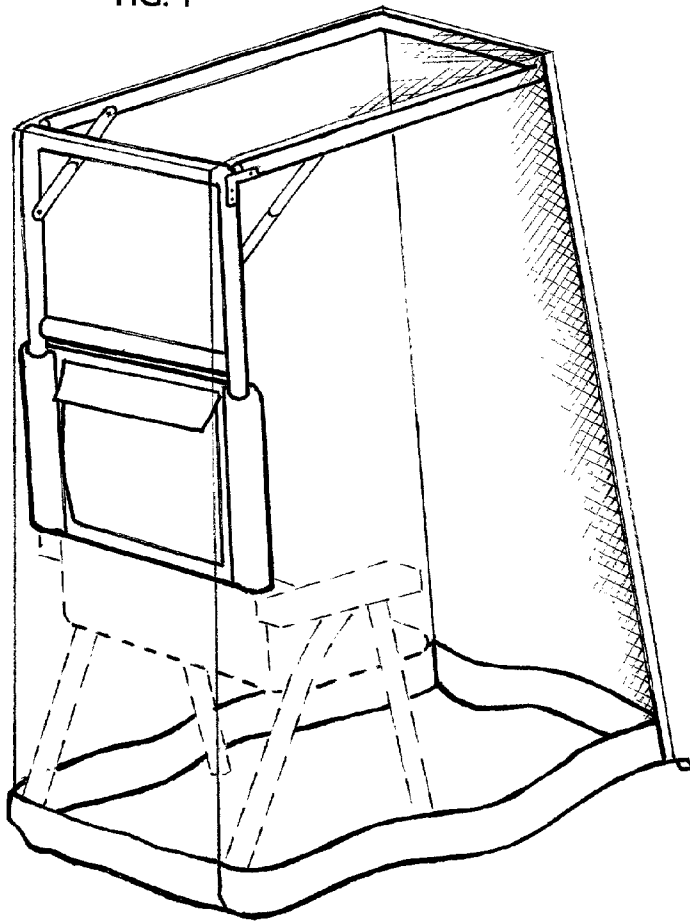

FIG. 2

FIG. 3

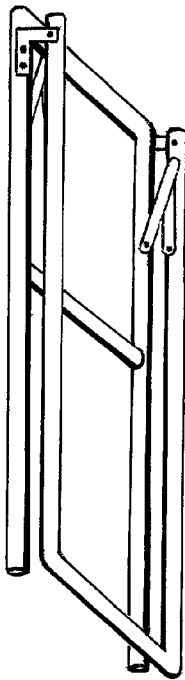

FIG. 4

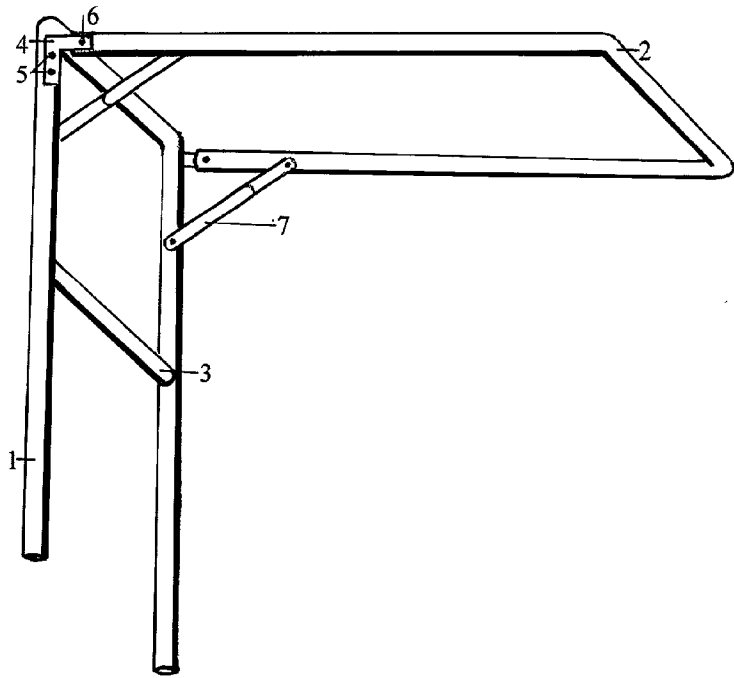

FIG. 5

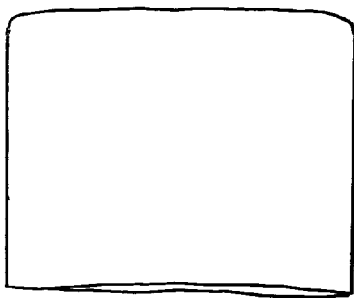
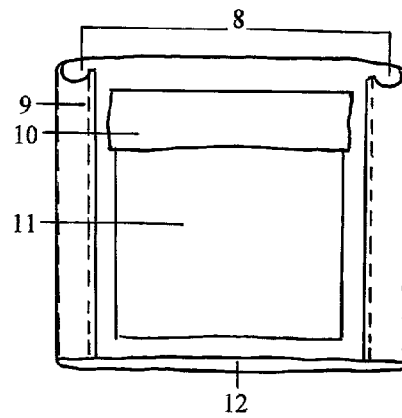

FIG. 6



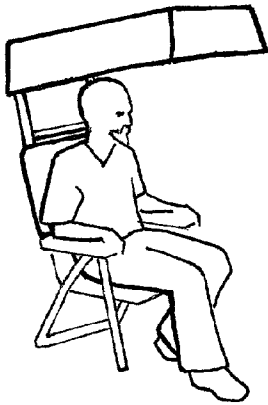

FIG. 7

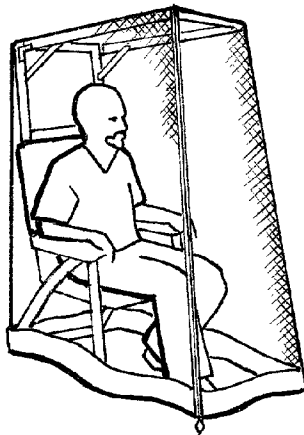

FIG. 8

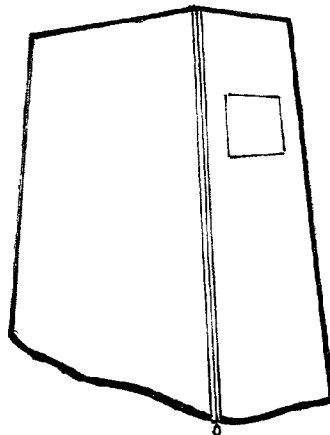

FIG. 9

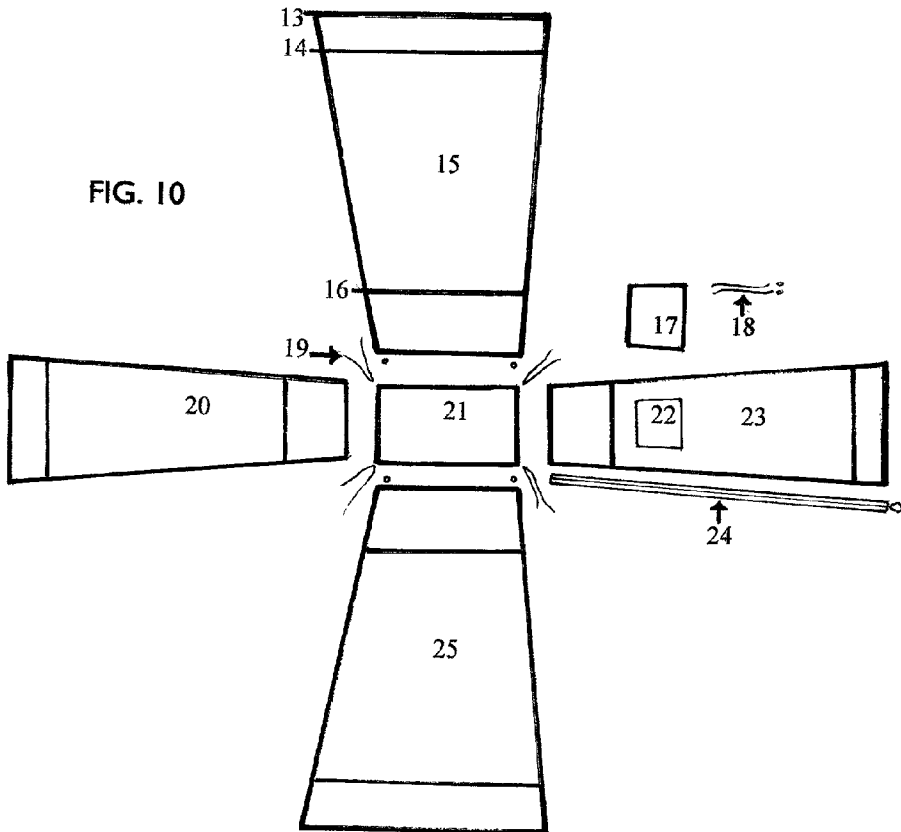
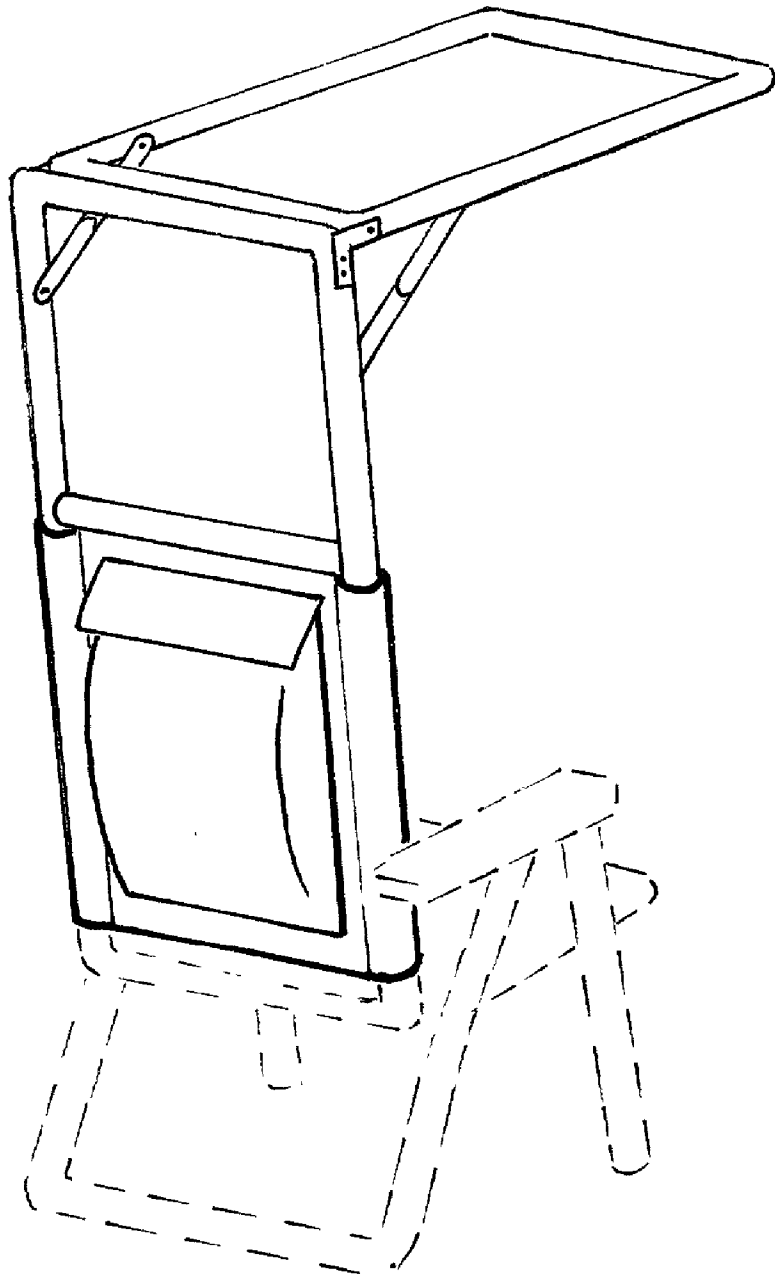

FIG. 10

FIG. 11



## CANOPY FRAME WITH OUTDOOR CANOPIES FOR CHAIR

### CROSS-REFERENCE TO RELATED APPLICATION

[0001] Not applicable.

### STATEMENT REGARDING FEDERALLY SPONSORED RESEARCH OR DEVELOPMENT

[0002] Not applicable.

### REFERENCE TO A MICROFICHE APPENDIX

[0003] Not applicable.

### BACKGROUND OF THE INVENTION

[0004] 1. Field of Invention

[0005] The Blakney Canopy Frame with Outdoor Canopies for Chair is a chair accessory. A sunshade, a mosquito or bug net, a blind or privacy screen, can all be draped over a chair and can be taken along as an extension of a folding chair to the beach or on a fishing trip. A very simple frame extends from a chairbag slipped over the back of a chair. The chairbag not only serves as the mechanism to attach the canopy frame, but also provides storage for the canopies.

[0006] 2. Description of Prior Art

[0007] The problem of how to mount a canopy frame to a chair was solved by modifying a chairbag. A chairbag is a fabric sleeve that is slipped over the back of a chair and has a storage pouch in back. School children in Zimbabwe where the inventor grew up, used them to store books. Because my design allows for a number of canopies to be used and stored with a chair, this design challenges the prior art of a number of inventions—sunshade attachments for chairs, seating combined with outdoor blinds, and chair designs that add storage pouches. Patented inventions that use similar principles to apply canopies or to add storage to chairs are many, the application of sunshades to chairs is particularly common, but each inventor has combined different mechanisms and has emphasized different purposes.

[0008] D312,931 Westfall et al., “Sun Shade for a Lawn Chair of the Like,” has a similar box top shaped sunshade and similar frame shape but attaches to chair with clamps rather than chairbag attachment. It does not collapse and does not incorporate other canopies.

[0009] U.S. Pat. No. 3,990,536 Wilburn, “Portable enclosure” incorporates seating with blind, but is stiff and mono-functional and mechanically complex in comparison to my invention.

[0010] U.S. Pat. No. 4,083,601 McBeth, “Outdoor Chair” incorporates seating with blind/windbreak, but can not be collapsed against a chair back and is much more complex mechanically.

[0011] U.S. Pat. No. 4,687,249 Mills, “Adjustable canopy for a wheel chair, beach chair, and the like,” has a similar frame concept. Legs or arms slip into cylinders or tubes that are like the cylindrical sleeves of a chairbag, but Mills uses no crossbar for back of frame and uses a different mechanism for bracing and adjusting the top canopy support.

[0012] U.S. Pat. No. 4,788,997 Clopton, “Portable Blind” incorporates seating with blind, but has a much more complex frame and is mono-functional.

[0013] U.S. Pat. No. 4,924,896 Carter, “Collapsible canopy structure for use in association with a chair or other free-standing device,” has a much more elaborate framework for supporting a canopy.

[0014] U.S. Pat. No. 4,971,089 Braman, “Folding Shelter” incorporates seating with blind, but does not collapse with a chair and is mono-functional.

[0015] U.S. Pat. No. 5,096,257 Clark, “Sunshade apparatus for chair,” uses different bracing and attachment mechanisms and does not incorporate other canopies.

[0016] U.S. Pat. No. 5,102,190 Atkin et al, “Portable sun shade,” has a frame that uses a similar set of braces to attach the back and top of frame together, but has no crossbar for back and attaches by means of straps instead of sleeves. Atkin also uses a completely different frame back construction.

[0017] U.S. Pat. No. 5,154,473 Joranco “Chair with sun screen and windbreaker panel,” uses a similar sleeve attachment concept. An “inverted pocket which fits over the back of a chair”, but the pocket is not independent as is the chairbag and is attached directly to a windbreaker panel.

[0018] U.S. Pat. No. 5,203,363 Kidwell et al, “Portable canopy attachment.” The back of the frame is very similar with crossbar and legs, but the frame has a completely different mechanism to support the canopy and the invention does not incorporate multipurpose canopies.

[0019] U.S. Pat. No. 5,582,458 Wildt, “Portable Lounge Chair” incorporates the idea of adding storage pouch to the back of a chair, but does not incorporate multipurpose canopies and has a different mechanical structure.

[0020] U.S. Pat. No. 5,641,197 Springman, “Collapsible Sports Chair” is also a multipurpose invention, but with different purposes. Springman does not incorporate multipurpose canopies and uses a different mechanical structure.

[0021] U.S. Pat. No. 5,727,841, Morley “Removable Accessory for Lounge Chair” has a storage compartment as part of chair attachment and the frame can remain part of the chair when collapsed, but the attachment does not rise above the back of the chair and it does not have parts that can be exchanged.

[0022] U.S. Pat. No. 5,752,537 Kranzler’s sunshade/windbreak provides an insect barrier, but it is freestanding and does not serve as a chair attachment.

[0023] U.S. Pat. No. 5,797,650 Gonzalez Jr., et al., “Sun shade attachment.” Much like Clark but even more complex, and is monofunctional.

[0024] U.S. Pat. No. 5,873,625 Uchtman “Folding chair with canopy.” Much like Carter this invention has a much larger framework to support a canopy.

[0025] U.S. Pat. No. 5,967,601 Gillins, “Sunshade apparatus for recreational chair,” uses similar rectangular U-shaped sections of frame, but they are attached and pivot with a different mechanisms. The frame collapses so that the top section is nested within the back section, rather than each section laying on top of each other as in my design.

[0026] U.S. Pat. No. 6,036,262 Shahid, "Carry-all-chair" uses the idea of adding storage to a chair, but does not incorporate multipurpose canopies and has different structural supports.

#### BRIEF SUMMARY OF THE INVENTION

[0027] The Blakney Canopy Frame with Outdoor Canopies for Chair provides a sunshade, mosquito or bug net, and a photography or changing blind for a chair. It is also portable, collapsing with or without a chair, and has a storage pouch for easy access to the canopies. Many inventors have designed chair extensions or attachments to support canopies. There are also chair designs that incorporate storage, and there are blind designs that incorporate seating. But, in comparison this invention is designed with minimal mechanism and with greater aesthetic application. No other design provides multipurpose, interchangeable canopies, readily stored, available, and portable. By combining many functions, and through simplicity of basic assembly design, this portable chair frame with matching canopies, surpasses all comparable inventions.

[0028] The problem of mounting a canopy frame to a chair has been solved in a completely unique way by using an independent fabric chairbag, instead of mechanical clamps or straps. When setting up canopies, or collapsing the frame for storage, no obtrusive parts can get caught on anything. The chairbag provides storage for canopies behind the chair's back, thereby not interfering with the folding mechanism of a chair. No other invention collapses completely with a variety of canopies for easy storage and transport either with or without a chair. No other invention has the aesthetic potential of this design. The frame, chairbag and canopies can all be coordinated with a chair to create a beautiful or romantic impression.

#### BRIEF DESCRIPTION OF NUMBERED DRAWINGS

[0029] FIG. 1 shows frame and mosquito net canopy attached to folding chair.

[0030] FIG. 2 shows frame collapsed with a folding chair and canopies stored in pouch.

[0031] FIG. 3 shows the frame collapsed.

[0032] FIG. 4 shows frame open and braced at right angles:

[0033] #1 points to back of the frame.

[0034] #2 points to top of the frame.

[0035] #3 points to crossbar.

[0036] #4 points to comer brace.

[0037] #5 points to fixed bolts.

[0038] #6 points to pivoting or loose bolt.

[0039] #7 points to folding brace.

[0040] FIG. 5 shows the front of the chairbag, against which a person's back rests.

[0041] FIG. 6 shows the back of the chairbag where the storage pouch and frame mounting sleeves are located.

[0042] #8 points to sleeve openings into which legs of frame are slipped.

[0043] #9 points to stitching of sleeve as determined by circumference of frame legs.

[0044] #10 points to storage pouch cover.

[0045] #11 points to storage pouch.

[0046] #12 points to sleeve opening which fits over the back of a chair.

[0047] FIG. 7 shows the sunshade in use.

[0048] FIG. 8 shows the mosquito netting in use.

[0049] FIG. 9 shows the blind in use.

[0050] FIG. 10 shows the basic canopy pattern from which canopies can be modified for use and decor.

[0051] #13 points to hem of blind and bug net.

[0052] #14 points to top edge of trim.

[0053] #15 left side panel.

[0054] #16 points to hem of sunshade.

[0055] #17 points to cover panel for blind viewing hole.

[0056] #18 points to attachment options for blind cover.

[0057] #19 points to attachment options for sunshade.

[0058] #20 back panel.

[0059] #21 top panel.

[0060] #22 blind viewing hole.

[0061] #23 front panel.

[0062] #24 points to zipper

[0063] #25 right side panel.

[0064] FIG. 11 shows the canopy frame design built into a chair

#### DETAILED DESCRIPTION OF THE INVENTION

[0065] The invention consists of three integral component parts: a frame (FIGS.3 &4); a chairbag(FIG. 5&6); a set of multipurpose canopies(FIGS.7&8&9). These component parts are all independent but are for use with a chair(FIG. 1) and can be stored with a chair(FIG.2).

[0066] The canopy frame is comprised of two sections, back and top (FIG. 4, #1&2). The frames are formed into rectangular U-shapes, the long sides of the U referred to here as legs. The back and top of the frame can be fixed at right angles to each other and the back and top of the frame can be collapsed on top of one another. Sleeves on the back of the chairbag (FIG. 6, #8) house and support the back of the canopy frame which extends up. The top of the frame is supported by folding braces (FIG. 4, #7) at a right angle to the back of frame so that the top can be extended over the chair seat. Interchangeable canopies (FIGS. 7 & 8 & 9) can then be draped from the over the top of the frame to encompass the entire chair. A storage pouch on the back of the chairbag (FIG.6,#11) stores the canopies that can be interchanged. All materials chosen are coordinated together to make an aesthetic impression.

### Frame

[0067] The canopy frame (FIGS. 3&4) consists of two sections, back (FIG. 4, #1) and top (FIG. 4, #2), that are fashioned out of framing material (any durable rod, bar or tubing material) that will be referred to here as tubing. The back and top sections of frame are formed into open, rectangular U-shapes. The long sides of the U-shaped frame are referred to here as legs.

[0068] The length of the legs of the back section of frame is about double the vertical height of the chair's back, while the base dimensions of the U-shaped frame match the width of the chair's back. A crossbar (FIG. 4, #3) is added between top and base of legs. The crossbar has two functions. First, to keep the legs parallel. Secondly, when the legs of the frame are inserted into the vertical sleeves, the crossbar reaches the top of the chair bag, it will stop and secure the frame. The crossbar supports the legs, so that when the legs are slipped down into the vertical sleeves, or lifted up in the vertical sleeves, there is enough tension to keep the frame in place. This allows the height of the canopy frame to be adjusted. The crossbar is measured so that its length will keep the legs of the frame parallel. The crossbar is attached by making two holes equal to the circumference of the crossbar on the inside of the aluminum legs. Then each end of the crossbar can be inserted and pinned or flayed to remain tightly in place with no intrusive attachment parts for to maintain a streamlined mechanism.

[0069] The top section of the frame is a matching rectangular U-shaped frame, although it can be a complete rectangle, minimal use of materials is the goal. The top section of the frame can be made out of the same or lighter tubing than the back section. The top section is attached to the back section of the frame with two sets of braces: ordinary corner braces (FIG. 4, #4); and collapsible braces as in those used for folding table legs (FIG. 4, #7).

[0070] The two corner braces are fastened with fixed bolts (FIG. 4, #5) to the outside edges at the closed end of the back section of the frame. Then the two corner braces are fastened with loose bolts (FIG. 4, #6) to the outsides of the legs at the open end of the top section of the frame so that the top section of frame can pivot and be collapsed (FIG. 3). The corner braces solve two problems. First the corner braces secure the two sections of frame together. Secondly, the corner braces provide the spacing needed so that the back section of the frame can be placed behind the chair's back while the top section of frame can pivot forward from the corner braces to lie flatly in front of chair's back (FIG. 2).

[0071] Two collapsible braces are used to support the top section of the frame at right angles to the back section of the frame, while allowing the top and back to be folded down on top of each other (FIG. 3). The collapsible braces are attached to the inside surfaces of the legs of the frame's top and back sections, each becoming the hypotenuse of a right angle, the right angle being a corner brace. This completes the canopy frame. This frame can also be built into a chair back—the crossbar being the top of the chair back and the legs of the frame being extensions from the sides of the chair back (FIG. 11).

### Chairbag

[0072] The chairbag (FIG. 5 & 6) is a fabric sleeve that fits over the back of a folding chair and allows the canopy frame

to be mounted to a chair back (FIG. 1) and provides storage for the canopies when not in use (FIG. 2). The chairbag is made out of fabric. It is constructed by first outlining the back of the chair to be fitted. A pattern is drawn which doubles the dimensions of the chair back, which adds space on all sides for a seam allowance, and which includes enough extra material so that the vertical edges can be turned over to make the cylindrical sleeves that will house the canopy frame legs. The material is cut and the edges are hemmed. Then the two vertical sides are stitched together so that the sleeve fits over chair back. The sleeve is turned right side out and this completes the main structure of the chair bag.

[0073] At the vertical edges of the chairbag, two cylindrical sleeves (FIG. 6, #9) are measured by curling the fabric around the legs of the frame. The sleeves should be measured to the circumference of the frame legs and stitched to hold those legs securely with tension that pulls the legs together slightly (FIG. 6, #9). The sleeves can then provide secure mounting of frame with a bit of tension so that the frame can be adjusted up and down to some extent. Material for a pouch (FIG. 6, #11) is measured. The pouch must be made of enough material to encompass the matching canopy set. The material is hemmed and three sides are stitched on to the outside of the chairbag, between the cylindrical frame sleeves. A cover is stitched over the open side (FIG. 6, #10). This completes the chairbag. The chairbag can also be built into a chair back with the canopy frame—instead of slipping over the chair back the fabric replaces the back surface of the chair (FIG. 11).

### Canopies

[0074] To make the canopy set a basic pattern is drawn. First the top of the canopy frame is traced (FIG. 10#21). Then the canopy frame is attached to the chair. Side dimensions are determined for both the short skirt of a sunshade (FIG. 7) & (FIG. 10#16) and the long skirt needed for the netting and blind (FIGS. 8&9) & (FIG. 10, #13). The netting and blind should be long enough so that the hem or trim can be anchored under chair legs for stability in the wind. Since the canopy frame may tilt back with the chair back and the top of the frame tilts up, the length of the canopy that drapes from the back of the chair is shorter than the length of the canopy that drapes down in front of the chair. Also the base of the canopy needs to encompass more space than the top of the canopy. So, with a person sitting in the chair, base dimensions are determined, making sure there is enough space to encompass the feet of the chair's occupant. The four vertical panels of the canopy (FIG. 10, #15, #20, #23, #25) are drawn at greater than right angles from the top.

[0075] The canopies can then be cut from the same pattern so that all can be used interchangeably. All canopies can be embellished with applications or buttons or colors or textures, to coordinate with the chairs they are made for, to reflect the places the canopies will be used, or just to make an artistic statement.

[0076] The sunshade (FIG. 7) is made out of opaque fabric. The top, two sides, front and back are cut according to the pattern (FIG. 10). The sunshade is hemmed at a length above the line of sight of a person sitting underneath it. Ties (FIG. 10, #19) are added to the inside corners so that the



sunshade can be secured to the canopy frame so that wind can not blow it off. Buttons or snaps can also be added to secure it to the mosquito or bug net canopy. This completes the basic sunshade canopy.

[0077] The mosquito or bug net canopy (**FIG. 8**) is preferably made out of dark mosquito netting, because it is much easier to see clearly through dark netting. The top, two sides, front, and back are cut according to the pattern (**FIG. 10**). These pieces are sewn together except for one front vertical edge that is connected by a zipper (**FIG. 10, #24**). A trim of weather resistant fabric (**FIG. 10, #14**) can be added to the base of the netting to protect the edges of the netting. The trim also adds weight to the base of the canopy making it more difficult for the wind to raise the skirt. The trim also adds stiffness so that the netting maintains a wider skirt and is less able to fall against the skin of the person sitting under it, which would allow bugs to bite. This completes the basic mosquito net canopy.

[0078] The blind canopy (**FIG. 9**) is made out of opaque fabric, not so heavy as to compromise the strength of the frame. The top, two sides, front, and back are cut according to the pattern (**FIG. 10**). The pieces are sewn together except for one front vertical edge that is connected by a zipper (**FIG. 10, #24**). In the front panel, a square hole is cut (**FIG. 10, #22**) so that it is in the line of sight of a person sitting in a chair under the canopy. A cover panel (**FIG. 10, #17**) is hemmed and attached above the hole as a cover with attachments to secure it (**FIG. 10, #18**). This completes the basic blind canopy.

What I claim as my invention is:

1. The combined use of a canopy frame; a set of canopies; and a chairbag or fabric sleeve that slips over a chair back with external sleeves to mount the frame and to store the canopies.

2. A collapsible canopy frame with two mounting legs stabilized by a crossbar between them that is comprised of two similar rectangular U-shaped frame sections, connected bottom of U to top of U with a set of corner braces and a set of folding braces so that the two frame sections can be supported at right angles to each other and can be collapsed flatly on top of each other with or without a chair back in between them.

3. A collapsible canopy frame as described in claim 2 with a top section of frame formed into a completed rectangular.

4. A mounting system for attaching a canopy frame to a chair comprised of a chairbag (fabric sleeve) that slips over the back of a chair with an external sleeve(pouch) for storage, on either side of which, on the outside edges, are two long vertical sleeves used to house the legs of a canopy frame.

5. A fabric canopy for draping over a canopy frame attached to a chair that is comprised of a rectangular top panel, with back/front panels and two side panels that are all cut at greater than a right angle from the top so that when the panels are all connected like a box top, the base dimensions of the canopy are considerably larger than the top dimensions of the canopy, with the greatest extension being in the front to allow for the extension of the legs of a person sitting in a chair over which the canopy is draped.

a) A blind canopy made out of opaque fabric to the specifications referred to in claim 4, hemmed to length that falls on the ground when it is draped over a canopy frame attached to a chair and to which is added a viewing hole with a cover panel set in the line of sight of the person sitting in the chair, and a zipper along a front vertical seam.

b) A mosquito or bug net canopy made out of netting to the specifications referred to in claim 4, hemmed to fall on the ground when it is draped over a canopy frame attached to a chair and to which is added a zipper along a front vertical seam.

c) A mosquito or bug net canopy made out of netting to the specifications referred to in claim 4, hemmed to fall on the ground when it is draped over a canopy frame attached to a chair and to which is added a stiff fabric trim added to the hem of the canopy.

d) A sunshade canopy made out of opaque fabric to the specifications referred to in claim 4, hemmed above the line of sight of a person sitting in the chair that can be used in tandem with the mosquito net canopy referred to in claim 4b and 4c.

6. A built in canopy frame and chairbag as described in claim 2, claim 3, claim 4, where the chairbag becomes the surface of the back of the chair and the legs of the canopy frame extend from the outer vertical supports of the chair back.

\* \* \* \* \*