

(19) World Intellectual Property Organization  
International Bureau



(43) International Publication Date  
1 November 2007 (01.11.2007)

PCT

(10) International Publication Number  
**WO 2007/123359 A2**

- (51) International Patent Classification:  
*H04L 12/66* (2006.01)
- (21) International Application Number:  
PCT/KR2007/001996
- (22) International Filing Date: 24 April 2007 (24.04.2007)
- (25) Filing Language: English
- (26) Publication Language: English
- (30) Priority Data:  
10-2006-0036568 24 April 2006 (24.04.2006) KR  
10-2006-0043828 16 May 2006 (16.05.2006) KR
- (71) Applicant (for all designated States except US): **KT-FREETEL CO., LTD.** [KR/KR]; 7-18, Sincheon-dong, Songpa-gu, Seoul, 138-240 (KR).
- (72) Inventors; and
- (75) Inventors/Applicants (for US only): **LEE, Jang-Won** [KR/KR]; 1010, Madu-dong, Ilsan-gu, Gyeonggi-do 410-350 (KR). **LEE, Ho-Jin** [KR/KR]; 1010, Madu-dong, Ilsan-gu, Gyeonggi-do, 410-350 (KR). **BAK, Sang-Man** [KR/KR]; 1010, Madu-dong, Ilsan-gu, Gyeonggi-do, 410-350 (KR).
- (74) Agent: **YOU ME PATENT AND LAW FIRM**; Seolim Bldg., 649-10, Yoksam-dong, Kangnam-ku, Seoul, 135-080 (KR).

- (81) Designated States (unless otherwise indicated, for every kind of national protection available): AE, AG, AL, AM, AT, AU, AZ, BA, BB, BG, BH, BR, BW, BY, BZ, CA, CH, CN, CO, CR, CU, CZ, DE, DK, DM, DZ, EC, EE, EG, ES, FI, GB, GD, GE, GH, GM, GT, HN, HR, HU, ID, IL, IN, IS, JP, KE, KG, KM, KN, KP, KZ, LA, LC, LK, LR, LS, LT, LU, LY, MA, MD, MG, MK, MN, MW, MX, MY, MZ, NA, NG, NI, NO, NZ, OM, PG, PH, PL, PT, RO, RS, RU, SC, SD, SE, SG, SK, SL, SM, SV, SY, TJ, TM, TN, TR, TT, TZ, UA, UG, US, UZ, VC, VN, ZA, ZM, ZW.
- (84) Designated States (unless otherwise indicated, for every kind of regional protection available): ARIPO (BW, GH, GM, KE, LS, MW, MZ, NA, SD, SL, SZ, TZ, UG, ZM, ZW), Eurasian (AM, AZ, BY, KG, KZ, MD, RU, TJ, TM), European (AT, BE, BG, CH, CY, CZ, DE, DK, EE, ES, FI, FR, GB, GR, HU, IE, IS, IT, LT, LU, LV, MC, MT, NL, PL, PT, RO, SE, SI, SK, TR), OAPI (BF, BJ, CF, CG, CI, CM, GA, GN, GQ, GW, ML, MR, NE, SN, TD, TG).

**Published:**  
— without international search report and to be republished upon receipt of that report

For two-letter codes and other abbreviations, refer to the "Guidance Notes on Codes and Abbreviations" appearing at the beginning of each regular issue of the PCT Gazette.

(54) Title: INTERWORKING SYSTEM BETWEEN IP NETWORKS USING DIFFERENT IP ADDRESSING SCHEME, APPLICATION LAYER GATEWAY (ALG), STUN SERVER, NETWORK ADDRESS TRANSLATOR, INTERWORKING METHOD THEREOF, AND SIP MESSAGE ROUTING METHOD THEREOF

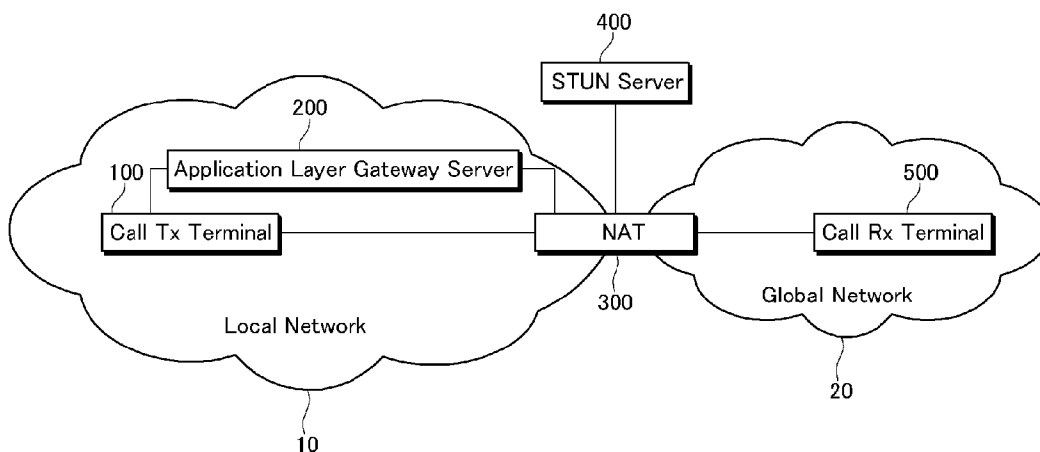

(57) Abstract: Disclosed are an interworking system between IP networks using different IP addressing scheme, an application layer gateway (ALG), a network address translator, an interworking method, and a SIP message routing method. The interworking system between a local network using a private IP and a global network using a global IP includes a STUN server and an application layer gateway (ALG). The STUN server provides binding information of header information of a global IP binding request. The application layer gateway (ALG) performs a global IP binding request with header information changed by IP masquerading, and performs routing by applying the received binding information to media receiving address information of a SIP message.

WO 2007/123359 A2

## Description

# INTERWORKING SYSTEM BETWEEN IP NETWORKS USING DIFFERENT IP ADDRESSING SCHEME, APPLICATION LAYER GATEWAY (ALG), STUN SERVER, NETWORK ADDRESS TRANSLATOR, INTERWORKING METHOD THEREOF, AND SIP MESSAGE ROUTING METHOD THEREOF

### Technical Field

- [1] The present invention relates to an interworking system between IP networks using different IP addressing scheme, an application layer gateway (ALG), a STUN server, a network address translator, an interworking method thereof, and a SIP message routing method thereof.

### Background Art

- [2] The IP multimedia subsystem (IMS) that is called the third generation network platform provides all the services on the IP basis, differing from the existing circuit-based network system.
- [3] The IMS that is the third generation switching system following the circuit switch and the soft switch combines voice and data service into a single structure and transmits the single structure to a device fixed to an IP network or a mobile device.
- [4] Also, the IMS has a meaning of changing the network to the open type by using the Internet protocol.
- [5] The IMS is a matter of primary concern in the communication field as it increases the flexibility of the wired/wireless network service to accelerate network convergence, it reduces application development and management costs, and it diversifies new services.
- [6] The IP network allocates an IP that is usable anywhere in the world, that is, a global IP address to each terminal, and identifies the address of the transmission source during a communication between the terminals.
- [7] However, as the IP network application as well as the IMS have been extended, the increase of usage thereof has made the capacity of the global IP addresses very insufficient.
- [8] Most of the communication service providers are using the network address translation (NAT) technique to attempt to ensure sufficient global IP addresses and security of networks of the communication service providers.
- [9] The NAT is an address translation technique of a communication network translating

the private IP addresses into global IP addresses.

[10] That is, the NAT allocates a private IP address available for a local network to the terminal.

[11] When the terminal uses another network or a public Internet, the private IP address allocated to the terminal is changed with a global IP address, and the global IP address is changed with the private IP address.

[12] Also, the port address translation (PAT), which is one of the NAT techniques, changes a port number of a TCP/UDP in addition to the IP address.

[13] Accordingly, the global IP address is used by a plurality of users to thus ameliorate the problem of insufficient global IP addresses.

[14] However, the NAT analyzes Layer 3 and Layer 4 headers of an OSI model and cannot analyze further higher layers, and the NAT cannot support Internet applications including recognition information (an address of the place of dispatch and a port of dispatch) of a packet generating host in a payload within the Layer 4 header of the packet, which is called the problem of the NAT-traversal.

[15] That is, the problem of the NAT-traversal means that the case of unavailable receipt routing is generated from the outside since the recognition information of the packet generating host is set as a receipt address of the terminal within the local network, that is, a private IP address cannot be changed to the global IP address by the NAT.

[16] The simple traversal under UDP through NAT (STUN) has been proposed as a prior art for solving the problem.

[17] The STUN scheme is based on the server-client, and it is located outside the NAT to provide the global IP address and port information allocated by the NAT.

[18] According to the STUN scheme, respective terminals for driving a STUN-client acquire a NAT-translated global IP address from a STUN server.

[19] However, since it is needed to drive the STUN-client for each terminal, it is difficult to apply the STUN to the network and the STUN acts on the terminal as a load.

[20] Also, a call transmitting terminal may not know whether a call receiving terminal is provided on the same network before a call connection.

[21] In this case, an unneeded process for accessing the STUN server through the NAT is performed even though the call receiving terminal is provided on the network requiring no passing through of the NAT.

[22] Therefore, an undesirable call process is generated and radio channels are wasted.

## **Disclosure of Invention**

### **Technical Problem**

[23] The present invention has been made in an effort to solve the NAT-traversal problem for interworking between the networks using different IP addressing scheme.

[24] The present invention has been made in another effort to provide SIP message routing for interworking the networks using different IP addressing scheme on the SIP basis.

[25] The present invention has been made in another effort to provide interworking for a SIP service between networks using SIP-based different IP addressing scheme.

### **Technical Solution**

[26] In one aspect of the present invention, an interworking system for interworking between a local network for using a private IP address and a global network for using a global IP address by using network address translation (NAT) includes: a STUN server, provided outside the NAT, for providing global IP binding information to a private IP address having passed through the NAT; and an application layer gateway (ALG), provided on the local network, for providing media receiving address information in a private IP format included in a payload of a call connection request packet received from a call transmitting terminal to the STUN server to receive media receiving address information that is translated into a global IP format, and applying the received media receiving address information to the received call connection request packet to transmit the same to a call receiving terminal.

[27] In another aspect of the present invention, an interworking method between a local network using a private IP address and a global network using a global IP address by using NAT includes: (a) extracting media receiving address information in the private IP format from a payload of a call connection request packet received by the local network from a call transmitting terminal; (b) transmitting a global IP binding request in which header information is changed with the extracted media receiving address information in the private IP format; (c) receiving a global IP binding response including the header information that is translated into the global IP by the NAT; and (d) transmitting the call connection request packet that is generated by changing the media receiving address information in the private IP format into the media receiving address information that is translated into the global IP received in (c) to a call receiving terminal.

[28] In another aspect of the present invention, an application layer gateway (ALG) for routing a session initiation protocol (SIP) message so as to perform interworking between a local network using a private IP address and a global network using a global IP address, the local network configuring a node includes: a message receiver for checking a transmitting subject and a method of a received SIP message; a message translator for performing NAT translation on the media receiving address information of the SIP message and real time control protocol (RTCP) receiving address information based on the checked result, and adding address information of the message

translator to the routing path of the SIP message; and a message transmitter for transmitting the SIP message translated by the message translator to the next routing path of the SIP message.

- [29] In another aspect of the present invention, a network address translator for routing a SIP message, the network address translator being provided on the boundary of a local network using a private IP address and a global network using a global IP address includes: a packet analyzer for analyzing a received packet and checking whether the packet has a SIP message; and an application layer gateway driver for performing a NAT translation on the media receiving and RTCP receiving address information by referring to a NAT translation table for the SIP message, and including address information of the application layer gateway driver in the routing path of the SIP message to route the same to the corresponding destination.
- [30] In another aspect of the present invention, a SIP message routing method of a node for interworking between a local network using a private IP address and a global network using a global IP address includes: (a) checking a transmitting subject and a method of the received SIP message; (b) applying the NAT address translation following the checked message transmitting subject and the method to the media and RTCP receiving address information of the SIP message; (c) specifying the address of the node selected based on the checked message transmitting subject in routing path information of the SIP message, the routing path determining a routing path of the next request message; and (d) routing the SIP message to the corresponding destination address.
- [31] In another aspect of the present invention, an interworking system for a SIP service between a local network using a private IP address and a global network using a global IP address includes: a STUN server for providing global IP binding information of the private IP address that is translated through NAT; and an application layer gateway (ALG) for providing media and RTCP receiving address information in the private IP format extracted from the SIP message received from a call transmitting terminal to the STUN server to receive address information that is translated into a global IP, applying the address information to the SIP message, and transmitting an applied result to a call receiving terminal.
- [32] In another aspect of the present invention, a SIP message routing method of a node for interworking between a local network using a private IP address and a global network using a global IP address includes: (a) transmitting a global IP binding request with changed header information to media and RTCP receiving address information in the private IP format extracted from the SIP message received from a call transmitting terminal; (b) receiving a global IP binding response including the header information translated into a global IP; and (c) applying the media and RTCP receiving address in-

formation translated into a global IP acquired from header information of the global IP binding response to the received SIP message, and transmitting an applied result to a call receiving terminal.

### **Advantageous Effects**

[33] According to the exemplary embodiments of the present invention, the problem of the NAT-traversal on the protocol separately having a call setting and a data transmitting/receiving is solved by using the conventional NAT without greatly changing the conventional STUN protocol.

[34] Also, when the STUN protocol is based on the server and the client, the STUN client function performed by the terminal is realized on the network node to thus minimize the load of the terminal and require no additional change or additional items on the existing terminal.

[35] Further, required changing items in the SIP message are substantially provided in order to solve the NAT-traversal problem of the SIP-based service, and hence, the present invention is directly applicable to the development and realization of the corresponding node.

### **Brief Description of the Drawings**

[36] FIG. 1 is a schematic diagram of an interworking system between IP networks using different IP addressing scheme according to a first exemplary embodiment of the present invention.

[37] FIG. 2 is a detailed functional block schematic diagram of an application layer gateway (ALG) according to a first exemplary embodiment of the present invention.

[38] FIG. 3 shows an IP header set by an application layer gateway (ALG) of FIG. 2.

[39] FIG. 4 shows a UDP header set by an application layer gateway (ALG) of FIG. 2.

[40] FIG. 5 is a detailed functioned block schematic diagram for a STUN server according to a first exemplary embodiment of the present invention.

[41] FIG. 6 shows an interworking method between IP networks using different IP addressing scheme according to a first exemplary embodiment of the present invention.

[42] FIG. 7 shows a brief SIP message routing method according to a second exemplary embodiment of the present invention.

[43] FIG. 8 shows a detailed example of a SIP message routing method according to a second exemplary embodiment of the present invention.

[44] FIG. 9 shows another detailed example of a SIP message routing method according to a second exemplary embodiment of the present invention.

[45] FIG. 10 and FIG. 11 show comparison between a pre-translation SIP message and a post-translation SIP message for SIP message routing according to a second exemplary embodiment of the present invention.

[46] FIG. 12 shows identification information for a SIP message transmitter and a method according to a second exemplary embodiment of the present invention.

[47] FIG. 13 is a block diagram for an application layer gateway (ALG) for performing SIP message routing according to a second exemplary embodiment of the present invention.

[48] FIG. 14 shows a SIP-based network interworking schematic diagram according to a second exemplary embodiment of the present invention.

[49] FIG. 15 is a detailed block diagram of a NAT according to a second exemplary embodiment of the present invention.

[50] FIG. 16 is a schematic diagram for an interworking network according to a third exemplary embodiment of the present invention.

[51] FIG. 17 shows a block diagram for an application layer gateway (ALG) according to a third exemplary embodiment of the present invention.

[52] FIG. 18 shows a flowchart for SIP message transmission according to a third exemplary embodiment of the present invention.

### **Best Mode for Carrying Out the Invention**

[53] In the following detailed description, only certain exemplary embodiments of the present invention have been shown and described, simply by way of illustration.

[54] As those skilled in the art would realize, the described embodiments may be modified in various different ways, all without departing from the spirit or scope of the present invention.

[55] Accordingly, the drawings and description are to be regarded as illustrative in nature and not restrictive.

[56] Like reference numerals designate like elements throughout the specification.

[57] Throughout this specification and the claims which follow, unless explicitly described to the contrary, the word “comprising” or variations such as “comprises” will be understood to imply the inclusion of stated elements but not the exclusion of any other elements.

[58] Also, the term of a unit, a device, a module, and a block in the present specification represents a unit for processing a predetermined function or operation, which can be realized by hardware, software, or a combination of hardware and software.

[59] An interworking system between IP networks using different IP addressing scheme, an application layer gateway (ALG), a network address translator, an interworking method thereof, and a SIP message routing method according to embodiments of the present invention will now be described with reference to drawings.

[60] Interworking between networks using different IP addressing scheme for solving the NAT-traversal problem according to a first exemplary embodiment of the present

invention will now be described.

- [61] FIG. 1 is a schematic diagram for an interworking system between IP networks using different IP addressing scheme according to a first exemplary embodiment of the present invention.
- [62] Referring to FIG. 1, a host (node) of the interworking system includes a call transmitting terminal 100, an application layer gateway (ALG) 200, a network address translator 300, a STUN server 400, and a call receiving terminal 500.
- [63] The interworking system is realized in an IP network 1 including a local network 10 using a private IP address and a global network 20 using a global IP address.
- [64] The interworking system uses a protocol that includes a signaling process for setting a call and a media session process for transmitting/receiving data, and has a packet payload having negotiation information of the media session process.
- [65] In the protocol, the payload of the application has host information, and a media session negotiation is performed between an end host that is the call transmitting terminal 100, and the call receiving terminal 500.
- [66] In further detail, the host information represents media receiving information for the end hosts to actually transmit and receive multimedia data such as audio and video, that is, address information of the call transmitting terminal 100 and the call receiving terminal 500 for receiving media.
- [67] The call transmitting terminal 100 and the call receiving terminal 500 are end hosts on the communication line of the IP network 1.
- [68] In this instance, the terminal (call transmitting) 100 is provided in the local IP network 10 and receives a private IP address.
- [69] The terminal (call receiving) 500 may be a terminal that is provided on the global IP network 20 and has received a global IP address, or a terminal that is provided in another local IP network and has received a corresponding private IP address.
- [70] The application layer gateway (ALG) 200 changes media receiving information in the private IP address format in the payload of the packet transmitted by the call transmitting terminal 100 into media receiving information in the global IP address format, and transmits the media receiving information in the global IP address format to the corresponding terminal (call receiving) 500.
- [71] That is, the application layer gateway (ALG) 200 performs an application layer gateway (ALG) function.
- [72] In this instance, the global IP address is acquired by requesting binding information of the global IP from the STUN server 400 and receiving a binding response.
- [73] Therefore, the application layer gateway (ALG) 200 functions as a STUN client for binding the global IP address.
- [74] In this instance, the binding request of the global IP address uses the IP mas-



querading technique.

[75] The IP masquerading is a networking function by Linux, in which internal computers connected to a Linux box respectively receive a virtual IP address to allow Internet connection by use of a single IP address.

[76] Therefore, when the IP masquerading is used, the header information of the binding request is changed into media receiving information in the private IP address format extracted from the payload of the packet received from the call transmitting terminal 100 and is transmitted to the application layer gateway (ALG) 200.

[77] A binding response received from the application layer gateway (ALG) 200 includes a global IP address of the header information changed into the media receiving information in the private IP address format.

[78] In this instance, the received binding information of the global IP address relates to the header information that is changed into the media receiving information, and hence, media receiving information in the global IP address format for the media receiving information in the private IP address format included in the packet payload is acquired.

[79] Therefore, the application layer gateway (ALG) 200 performs an IP masquerading function.

[80] The network address translator (NAT) 300 is provided on the boundary of the local network 10 and the global network 20 to translate source address information in the private IP address format included in the header of the packet into source address information in the global IP address format.

[81] Also, the NAT translates source address information in the global IP address format into source address information in the private IP format.

[82] The source IP address information includes an IP address and a port.

[83] In this instance, the address translation is allowable for the network layer and the transport layer that correspond to Layer 3 and Layer 4 with reference to the open system interconnection (OSI) model.

[84] The STUN server 400 uses the STUN (Simple Traversal of User Datagram Protocol Through Network Address Translators) protocol to provide binding information of the global IP address to a STUN client.

[85] That is, the STUN server 400 functions as a server corresponding to the client for binding the global IP address of the STUN server.

[86] Therefore, on receiving a binding request from the application layer gateway (ALG) 200, the STUN server 400 extracts header information of the packet that is translated into the global IP address while undergoing the process by the network address translator 300.

[87] The STUN server 400 loads the header information in the binding response and

transmits the same to the application layer gateway (ALG) 200.

[88] In this instance, the STUN server 400 checks a response receiving address of the binding request and transmits a binding response to the checked address, and it is desirable for the application layer gateway (ALG) 200 to set the binding response address as an IP address of the application layer gateway (ALG) 200 in the case of the binding request.

[89] FIG. 2 is a detailed functional block schematic diagram for an application layer gateway (ALG) in the interworking system of FIG. 1 according to a first exemplary embodiment of the present invention.

[90] Referring to FIG. 2, the application layer gateway (ALG) 200 includes an IP masquerading performer 210, a STUN client performer 220, an address translator 230, a proxy performer 240, and a determiner 250.

[91] The IP masquerading performer 210 performs IP masquerading.

[92] In detail, the IP masquerading performer 210 may include a header information setting module 212, and a header checksum calculation module 214.

[93] The header information setting module 212 sets the media receiving information extracted from the payload of the packet received from the call transmitting terminal 100 to be header information of the packet for a binding request to be transmitted to the STUN server 400.

[94] The setting of header information will now be described with reference to FIG. 3 and FIG. 4.

[95] Referring to FIG. 3 showing an IP header, the parameter "Source IP Address"(P103) is changed with media receiving information of the call transmitting terminal 100.

[96] FIG. 4 shows a UDP header in which the parameter "Source port" (P105) is changed with the media receiving information of the call transmitting terminal 100.

[97] In this instance, as described in FIG. 1, the media receiving information is an IP address for the call transmitting terminal 100 and the call receiving terminal 200 to receive media, and it is allocated as a private IP address.

[98] The header checksum calculation module 214 recalculates the parameter "Header Checksum" (P101) of the IP header by applying the IP address changed by the header information setting module 212, and can also recalculate the parameter "Checksum" (P107) of the UDP header.

[99] However, since the UDP layer does not recalculate the parameter "Checksum" (P107), the recalculation is not always needed

[100] The STUN client performer 220 functions as a client corresponding to the STUN server 400 for providing binding information of the global IP address.

[101] That is, the STUN client performer 220 transmits a packet for a binding request with the header information changed by the IP masquerading performer 210 to the STUN

server 400.

[102] In this instance, the STUN client performer 220 sets a response address of the binding request to be an IP address of the application layer gateway (ALG) 200, and transmits the same.

[103] On receiving a binding response from the STUN server 400, the STUN client performer 220 extracts global IP binding information of header information from the binding response.

[104] The address translator 230 functions as an application layer gateway for changing the media receiving information in the private IP address format included in the payload of the packet into media receiving information in the global IP address format.

[105] That is, the address translator 230 changes the media receiving information in the private IP address format into the global IP binding information of the header information extracted by the STUN client performer 220.

[106] In this instance, since the header information is given when it is changed with the media receiving information in the private IP address format by the IP masquerading performer 210, corresponding global IP binding information corresponds to the media receiving information in the global IP address format.

[107] Also as shown in FIG. 2, the application layer gateway (ALG) 200 may include a proxy performer 240.

[108] The proxy performer 240 performs a call repeating function.

[109] That is, the proxy performer 240 performs a proxy function of receiving a call connection request from the call transmitting terminal 100, transmitting the call connection request to the call receiving terminal 500, receiving a call connection response from the call receiving terminal 500, and transmitting the call connection response to the call transmitting terminal 100.

[110] In this instance, the call connection request transmitted to the call receiving terminal 500 is a packet that is provided by the address translator 230 and is generated by translating the media receiving address information of the payload into the global IP address.

[111] Also, as shown in FIG. 2, the application layer gateway (ALG) 200 may include a determiner 240.

[112] The determiner 240 interworks with the IP masquerading performer 210 and the proxy performer 240.

[113] The determiner 240 checks the destination of the received packet header to determine whether the network of the call transmitting terminal 100 corresponds to the network of the call receiving terminal 500 and then determines whether to perform IP masquerading.

[114] In this instance, when it is determined to perform IP masquerading, the determination

is provided to the IP masquerading performer 210.

[115] Therefore, according to the above-noted configuration of the application layer gateway (ALG) 200, the STUN client performer 220 performs a client function of the global IP binding, and determines whether to perform global IP binding by control of the determiner 240.

[116] Accordingly, the global IP binding is not performed on the same network on which no address translation is required before negotiation of a communication session is finished.

[117] FIG. 5 is a detailed functioned block schematic diagram for a STUN server in the interworking system of FIG. 1.

[118] Referring to FIG. 5, the STUN server 400 functions as a server for the global IP binding.

[119] In detail, the STUN server 400 may include a storage unit 410 and a STUN performer 420.

[120] The storage unit 410 stores setting information for processing the global IP binding by interworking with the application layer gateway (ALG) 200, particularly the STUN client performer 220.

[121] The STUN performer 420 extracts global IP address information translated by the network address translator 300 from the header information of the global IP binding request received from the STUN client performer 220 according to the setting information of the storage unit 410.

[122] Also, the STUN performer 420 extracts the set response address from the response address information of the global IP binding, loads the extracted global IP address information in the global IP binding response, and transmits the global IP address information to the extracted response address.

[123] FIG. 6 shows an interworking method between IP networks using different IP addressing scheme according to a first exemplary embodiment of the present invention.

[124] On receiving a private IP address, the call transmitting terminal 100 transmits a call connection request to the application layer gateway (ALG) 200 (S101).

[125] Steps of S103, S105, and S107 can be further included before the step S109.

[126] The application layer gateway (ALG) 200 determines (S103) whether the call transmitting terminal 100 and the call receiving terminal 500 are provided on the same network from the call connection request received in S101.

[127] The application layer gateway (ALG) 200 determines the network state by comparing the IP address specified in the destination (that corresponds to the parameter "Destination IP Address" of the IP header) of the call connection request and the IP address specified in the source (that corresponds to the parameter "Source IP Address" of the IP header).

- [128] Since there is no need to perform the network address translator 300 when the call transmitting terminal 100 and the call receiving terminal 500 are provided on the same network requiring no IP address translation according to the determination result of S103, the call connection request of the call transmitting terminal 100 is transmitted to the call receiving terminal 500 (S107).
- [129] Since there is a need to change the IP address when the call transmitting terminal 100 and the call receiving terminal 500 are provided on the different networks according to the determination result of S103, it is determined to perform the IP masquerading.
- [130] The application layer gateway (ALG) 200 performs IP masquerading (S109).
- [131] That is, the application layer gateway (ALG) 200 extracts media receiving information from the payload of the packet for the call connection request received in S101, changes the media receiving information with header information of the packet for the global IP binding request to be transmitted to the STUN server 400, and transmits the IP masqueraded global IP binding request to the STUN server 400 (S111).
- [132] In this instance, the global IP binding request includes response address information that is set to be an IP address of the application layer gateway (ALG) 200.
- [133] The STUN server 400 performs a global IP binding operation (S113).
- [134] That is, STUN server 400 extracts header information translated into the global IP address from the global IP binding request received through the network address translator 300, and includes the extracted header information in the global IP binding response.
- [135] The STUN server 400 uses the IP address of the application layer gateway (ALG) 200 included in the response address information of the global IP binding request to transmit a global IP binding response to the application layer gateway (ALG) 200 (S115).
- [136] The application layer gateway (ALG) 200 receives the global IP binding response and performs an application layer gateway function (S117).
- [137] That is, the application layer gateway (ALG) 200 changes the media receiving information of the payload of the call connection request received in S101 into header information changed into the global IP address extracted from the binding response.
- [138] The application layer gateway (ALG) 200 transmits the call connection request that is generated by changing media receiving information of the packet payload into the global IP address format to the call receiving terminal 500 through the network address translator 300 (S119), and receives a call connection response from the call receiving terminal 500 (S121), and hence, a call connection is provided between the call transmitting terminal 100 and the call receiving terminal 500.
- [139] Accordingly, when the network address translator 300 translates header information

of the call connection request into the global IP address, media session negotiation is fluently performed since the media receiving information is translated into the global IP address format through the steps of S109, S111, S113, S115, and S117.

- [140] SIP routing between networks using different IP addressing scheme for solving the NAT-traversal problem according to a second exemplary embodiment of the present invention will now be described.
- [141] FIG. 7 shows a brief SIP message routing method according to a second exemplary embodiment of the present invention.
- [142] Referring to FIG. 7, a message transmission subject and a method of the received SIP message are checked (S201).
- [143] The message transmission subject represents a call transmitting/receiving subject, and the method indicates whether a message is a request message or a response message.
- [144] In this instance, the SIP message includes a request message and a response message.
- [145] A NAT address translation appropriate for the contents checked in S201 is applied to the media and real time control protocol (RTCP) receiving address information of the received SIP message (S203).
- [146] That is, the NAT address translation is performed according whether the transmitting subject of the received SIP message is a local network or a global network and whether the message is a request message or a response message.
- [147] Also, a NAT address translation can be performed on transport information of the SIP message, which is not always needed since a global IP address is allocated to the SIP message routing node.
- [148] Here, the transport includes a subject having transmitted the SIP message, that is, a host name or network address information of the SIP client.
- [149] An address of the node appropriate for the contents checked in S201, that is, an address of the node for performing SIP message routing, is included in the routing path of the SIP message (S207).
- [150] In this instance, the routing path determines a route path of the next request message (e.g., UPDATE and PRACK).
- [151] The subsequently received SIP message receives a SIP service request message by using a private IP address of the node according to the determined routing path when the transmitting subject is a local network.
- [152] Also, the subsequently received SIP message receives a SIP service request message by using a global IP address of the node when the transmitting subject is a global network.
- [153] The SIP message translated through the steps of S203 and S205 is routed to the corresponding destination address (S207).

- [154] A SIP message routing method depending on the SIP message transmitting subject and the method will now be described in detail.
- [155] FIG. 8 shows a detailed example of a SIP message routing method according to a second exemplary embodiment of the present invention, showing 'Case 1' (P201).
- [156] Referring to FIG. 8, an SIP message having a local network as a message transmitting subject and a session invite request as a method is received (S301).
- [157] The media and RTCP address allocated from the place of dispatch specified in the session description protocol (SDP) field of the SIP message received in S301 are extracted (S303).
- [158] In this instance, the extracted address is an IP of the address of the place of dispatch, that is, it has a private IP format.
- [159] The global IP address for the address extracted in S303 is allocated and translated (S305).
- [160] The address allocation information performed in S305 is temporarily stored (S307).
- [161] The global IP address of the node performing SIP routing is specified in the routing path of the SIP message translated in S307 (S309).
- [162] The SIP message in which the routing path is specified in S309 is transmitted to the destination address (S311).
- [163] In this instance, a global IP address can be allocated by using a NAT address translation table in S305.
- [164] Also, the global IP address can be allocated by using a query method using a server.
- [165] The query method using an external server can use a STUN protocol.
- [166] In this instance, the global IP address allocation process using the STUN protocol changes the media and RTCP receiving address of the SIP message into IP header information of the STUN binding message to acquire a corresponding NAT binding value.
- [167] FIG. 9 shows a detailed SIP message routing method according to a second exemplary embodiment of the present invention, showing the 'Case 2' (P203).
- [168] Referring to FIG. 9, a SIP message having a global network as a message transmitting subject and a session invite response as a method is received (S401).
- [169] The media and the RTCP address corresponding to the place of dispatch specified in the SDP field of the SIP message received in S401 are extracted (S403).
- [170] A private IP address of the address extracted in S403 is searched to map the private IP address on the extracted address and store a result in the SIP address allocation table (S405).
- [171] A private IP address of the node for performing SIP message routing is inserted (S407) in the routing path of the SIP message having undergone the step of S405.
- [172] The SIP message having undergone the step of S407 is transmitted to the destination

address (S409).

[173] FIG. 10 and FIG. 11 show comparison between a pre-translation SIP message and a post-translation SIP message for SIP message routing according to a second exemplary embodiment of the present invention, showing the 'Case 1' (P201).

[174] When FIG. 10 and FIG. 11 are compared, the field that is translated for routing in the SIP message includes an SDP field (P305), a via header field (P301), and a record-route field (P303).

[175] In detail, the SDP field (P305) translates the 'media receiving port (attribute m)' field (P307), the 'media receiving IP address (attribute c)' field (P309), and the 'RTCP receiving IP address and port (attribute a)' field (P311).

[176] The 'media receiving port (attribute m)' field (P307) stores the media receiving port value allocated by the place of dispatch as a NAT translated value.

[177] In this instance, the translation is performed for the respective media types including audio, video, and text (P313, P315, and P317), which is needed to make the media be receivable from the external network, that is, the global network.

[178] The 'media receiving IP address (attribute c)' field (P309) is changed to a value that is NAT-translated from the media receiving IP address allocated by the place of dispatch.

[179] In a like manner, the translation is performed for the respective media types including audio, video, and text (P313, P315, and P317), which is needed to make the media be receivable from the external network, that is, the global network.

[180] The 'RTCP receiving IP address and port (attribute a)' field (P311) is changed to a value that is NAT-translated from the RTCP receiving IP address and port value allocated by the place of dispatch.

[181] In this instance, the translation is performed for the respective media types including audio, video, and text (P313, P315, and P317), which is needed to make the RTCP receiving be available from the external network, that is, the global network.

[182] Compared to FIG. 10, translated portions of the respective fields (P307, P309, and P311) of FIG. 11 are given bold type letters.

[183] The via header field (P301) supports the rport function in the via header, and the message transmitted from the call transmitting terminal includes the 'rport' parameter.

[184] In this case, it is desirable to extract the 'IP address' of the via header field including the 'rport' parameter and the 'source port' of the message and specify the same on the 'received' parameter and the 'rport' parameter to thus rewrite the via header.

[185] Since the node for performing SIP message routing has a global IP address appropriately mapped by the NAT, the address translation of the node performing SIP message routing is not an imperative operation.

[186] The record-route field (P303) is a field for specifying a proxy address depending on



the message transmitting subject so as to make routing of the next request (e.g., UPDATE and PRACK) message possible.

[187] In this instance, the record-route field is needed since the next request message is to be routed so as to pass through the node for performing a SIP ALG function.

[188] The message transmitted from the local network to the global network specifies a global IP address depending on the message transmitting subject.

[189] Also, the message transmitted from the global network to the local network specifies a private IP address.

[190] When FIG. 10 and FIG. 11 are compared, the media receiving address (private) is 10.10.10.14 (audio: 20000, video: 20002, text: 20004).

[191] The media receiving address (global) is 200.200.200.1 (audio: 20000, video: 20002, text: 20004).

[192] The rtcp receiving address (private) is 10.10.10.14 (port: 20001) and the rtcp receiving address (global) is 200.200.200.1 (port: 20001), which represents that the private receiving address is 10.10.10.14 (ports are audio: 20000, video: 20002, and text: 20004) and the NAT translated value of the IP address/port is 200.200.200.1 (ports are audio: 20000, rtcp: 20001, video: 20002, text: 20004) since the call transmitting terminal (ue1) has a private IP address.

[193] The (private) address of the node for performing routing on the SIP message is 10.10.10.11 and the (global) address is 200.200.200.201.

[194] FIG. 13 is a block diagram for an application layer gateway (ALG) for performing SIP message routing according to a second exemplary embodiment of the present invention, showing a configuration of a node for performing SIP message routing described with reference to FIG. 7 to FIG. 12.

[195] The configuration of the network including the application layer gateway (ALG) corresponds to that shown in FIG. 1.

[196] In this instance, the detailed configuration of the application layer gateway (ALG) will be described with reference to FIG. 13.

[197] Referring to FIG. 13, the application layer gateway (ALG) (200 in FIG. 1) includes a message receiver 260, a message translator 270, and a message transmitter 280.

[198] The message receiver 260 receives a SIP message to check the message transmitting subject and a method.

[199] The message translator 270 performs a NAT address translation on the SIP message media and RTCP receiving address information based on the checked contents of the message receiver 260, and includes address information of the node in the SIP message routing path.

[200] In this instance, the message translator 270 includes a SIP address allocation storage module 272, a SIP address allocation module 274, a SIP address mapping module 276,

- and a SIP message translation module 278.
- [201] The SIP address allocation storage module 272 stores mapped NAT address pre/post-translation information.
- [202] The SIP address allocation module 274 performs a global IP allocation on the media of the received SIP message having the local network as a transmitting subject and a session invite request as a method and host information on RTCP receipt.
- [203] The SIP address mapping module 276 maps the media of the SIP message having the global network as a transmitting subject and a response to the session invite request as a method and host information for RTCP receipt on SIP address pre-allocation information by the SIP address allocation module 274 and stores a mapped result in the SIP address allocation storage unit 222.
- [204] The SIP message translation module 278 performs an appropriate SIP address translation in cooperation with the SIP address allocation module 274 and the SIP address mapping module 276, specifies the global IP address of the application layer application layer gateway (ALG) 200 on the routing path of the session invite request message, and specifies a private IP address of the application layer application layer gateway (ALG) 200 on the routing path of the response message for the session invite request.
- [205] The SIP message translation module 278 includes a first address translation module 278a, a second address translation module 278b, and a routing path generating module 278c.
- [206] The first address translation module 278a performs an address translation on the SIP message media and host information for RTCP receipt.
- [207] The second address translation module 278b performs an address translation on the transport information of the SIP message.
- [208] Here, the transport includes a host name or a network address of the transmitting subject.
- [209] The routing path generating module 278c generates the routing path of the response for the SIP service request message as a global IP address or a private IP address of the application layer application layer gateway (ALG) 200 according to the message transmitting subject.
- [210] The message receiver 260 receives a service request message or a service response message by using the private IP address or the global IP address.
- [211] The message transmitter 280 transmits the message translated by the message translator 270 to an appropriate routing path.
- [212] FIG. 14 shows a SIP-based network interworking schematic diagram according to another second exemplary embodiment of the present invention, showing an application of the SIP message routing method described with reference to FIG. 7 to FIG.

12 to the existing NAT technique.

[213] In this instance, the NAT address translation uses a NAT translation table.

[214] Referring to FIG. 14, the SIP-based network interwork schematic diagram includes a call transmitting terminal 600, a network address translator 700, and a call receiving terminal 800.

[215] The call transmitting terminal 600 and the call receiving terminal 800 will not be described since they correspond to the above-described technique.

[216] The network address translator 700 is provided on the boundary of the local network 30 and the global network 40 to perform a NAT function, and performs a SIP application layer gateway function to enable the SIP-based network interworking.

[217] The detailed configuration of the network address translator 700 will now be described referring to FIG. 15.

[218] Referring to FIG. 15, the network address translator 700 includes a packet analyzer 720 and an application layer gateway driver 740.

[219] The packet analyzer 720 analyzes the received packet to check whether it is a SIP message by analyzing an address of the place of generation and a port number of the packet.

[220] That is, the SIP message can be checked by using the port number since the SIP uses the port number of 5060 as a default.

[221] When the message is found to be a SIP message according to the checking result by the packet analyzer 720, the application layer gateway driver 740 refers to the NAT translation table to perform a NAT translation on the host information for receiving media and RTCP, includes address information of the application layer gateway driver 740 in the routing path, and routes to the corresponding destination.

[222] In this instance, when the received packet is not a SIP message, the application layer gateway driver 740 translates the IP header or other additional components in a like manner of other packets to transmit them to an upper layer, thereby performing the existing NAT operation.

[223] Here, the application layer gateway driver 740 includes a message analysis module 742, a SIP address allocation module 744, a first message translation module 746, and a second message translation module 748.

[224] The message analysis module 742 analyzes the method and message transmitting subject of the SIP message transmitted from the packet analyzer 710.

[225] The SIP address allocation module 744 performs SIP address allocation and mapping appropriate for the analyzing method and message transmitting subject by using the NAT address translation table.

[226] The SIP address allocation module 744 includes an allocator 744a and a mapper 744b.

- [227] The allocator 744a allocates a global IP corresponding to the SIP message's media and RTCP receiving address information by using the NAT address translation table.
- [228] The mapper 744b maps the allocated global IP address and the pre-allocated private IP address for the media and RTCP address information to configure a SIP address allocation table.
- [229] The first message translation module 746 performs a SIP message translation by using the address allocated by the SIP address allocation module 744.
- [230] In this instance, it is possible to apply the allocated global IP to transport information of the SIP message, that is, information including one of a host name or a network address of the transmitting subject.
- [231] The second message translation module 748 includes the global IP address of the second message translation module 748 in the routing path when the transmitting subject of the SIP message is a local network, and it includes the private IP address of the second message translation module 748 in the routing path when the transmitting subject is a global network.
- [232] Referring to FIG. 7 to FIG. 15, needed translation items of the SIP message header are minimized to include the parameters 'm' and 'c' of the address SDP, the parameters 'a' of the RTCP, and the 'record-route' parameter.
- [233] Therefore, the SIP-based network interwork can be realized between the local network and the global network without translating a plurality of fields such as Request-URI, Via, Contact, Route, From, To, Error-info, Proxy-authenticate, WWW-authenticate, and Warning of the SIP message.
- [234] SIP message routing using a STUN protocol between the IP networks using different IP addressing scheme according to a third exemplary embodiment of the present invention will now be described.
- [235] FIG. 16 is a schematic diagram for an interworking network configuration between IP networks using different IP addressing scheme according to a third exemplary embodiment of the present invention.
- [236] Referring to FIG. 16, a SIP user agent A 900 is provided on the mobile communication network 50 and is connected to the radio access network (RAN).
- [237] The radio access network includes a base station 1000 and a packet data serving node (PDSN)/gateway GPRS serving node (GGSN) 1100 and represents a network connected to the SIP user agent A 900 through a radio network.
- [238] The base station 1000 converts the analog signal received from the SIP user agent A 900 in the service cell into a digital signal and transmits the digital signal to the PDSN/GGSN 1100 connected through a cable, and converts the digital signal received from the PDSN/GGSN 1100 into an analog signal to transmit the same to the SIP user agent A 900.

- [239] The PDSN/GGSN 1100 performs IP address allocation/management/routing.
- [240] That is, the PDSN/GGSN 1100 translates the digital signal received from the base station 1000 into an IP packet and transmits the IP packet to the Internet 60, and translates the IP packet received from the Internet 60 into a digital signal and transmits the same to the base station 1000.
- [241] Therefore, the SIP user agent A 900 can exchange the IP packet type SIP message with the SIP user agent B 1500 through the radio access network.
- [242] The application layer gateway (ALG) 1200 performs a SIP application level gateway (ALG) function, an IP masquerading function, a STUN client function, and a SIP proxy function.
- [243] The SIP ALG function is an ALG function for allocating and translating a source IP address and a source port of the SIP message into an IP format that is call receivable from the Internet.
- [244] In detail, address/port information in the “m(media)/c(connection) line” in the content (SDP unit) of the invite message is translated into an IP format available for interworking with the Internet 60 by setting an IP address and a port of the SIP user agent A 600 to the packet through the IP masquerading function.
- [245] The STUN client function requests a global IP address (IP address and port) from the STUN server 1400 and receives the same so that the SIP user agent A 900 may receive media from the Internet 60, which is called a STUN binding operation.
- [246] The SIP proxy function performs a proxy server between the SIP user agents A and B (900, 1500).
- [247] The above-configured application layer gateway (ALG) 1200 solves the NAT-traversal problem by using the SIP message in the case of interworking with the Internet 60, and minimizes the terminal load since the STUN client is provided as an additional device not on the SIP user agent A 900 but on the node.
- [248] Further, the application layer gateway (ALG) 1200 can perform the STUN binding operation after receiving the invite message so that a session connection is available without STUN binding when the SIP user agent B 1500 is on the mobile communication network 60, which prevents the call processing problem and the radio channel waste caused by performing a STUN binding operation irrespective of the network on which the call receiving SIP user agent is located as a STUN client is installed in the terminal.
- [249] The NAT unit 1300 allocates and translates a source IP address and a source port of the packet into a global IP so that call receiving may be possible in the case of interworking the mobile communication network 50 and the Internet 60.
- [250] The STUN server 1400 is provided outside the NAT unit 1300.
- [251] The STUN server 1400 notifies the STUN client, that is, the application layer

gateway (ALG) 1200 of a global IP address and a port allocated by the NAT unit 1300 when the SIP-user agent A 900 provided on the mobile communication network 30 interworks with the Internet 60.

[252] FIG. 17 shows a block diagram for an application layer gateway (ALG) according to a third exemplary embodiment of the present invention.

[253] Referring to FIG. 17, the application layer gateway (ALG) (1200 of FIG. 16) includes a proxy performer 1202, a determiner 1204, an IP masquerading performer 1206, a STUN client performer 1208, and a message translator 1210.

[254] The proxy performer 1202 performs a proxy function of the SIP message.

[255] The determiner 1204 determines the network and message types by checking the transmitting subject and the method of the received SIP message, thereby determining whether the network of the call transmitting terminal corresponds to the network of the call receiving terminal, and determining whether the SIP message is a request message or a response message.

[256] The IP masquerading performer 1206 changes header information of the global IP binding request to be transmitted to the STUN server (1400 of FIG. 16) with the attribute value of m/c/a extracted from the SDP of the SIP message.

[257] In this instance, the attribute value of m/c/a includes media and RTCP receiving address information.

[258] The IP masquerading performer 1206 changes the source IP address and the source port of the header information of the global IP binding request with the attribute value of m/c/a of the received SIP message.

[259] In this instance, the changing process is performed when the network of the call transmitting terminal is different from that of the call receiving terminal and the received SIP message is a session invite request message based on the determination result of the determiner.

[260] The STUN client performer 1208 transmits the global IP binding request with the header information changed by the IP masquerading performer 1206 to the STUN server, and receives a global IP binding response including changed header information bound with the global IP.

[261] The message translator 1210 acquires the attribute value of m/c/a translated into the global IP from the changed header information received by the STUN client performer 1208, and applies the attribute value of m/c/a to the received SIP message.

[262] Also, the message translator 1210 selects one of the global IP address and the private IP address of the message translator 1210 that are selected based on the transmitting subject of the SIP message determined by the determiner 1204, and describes the selection result on the routing path of the SIP message.

[263] The routing path determines the routing path of the next request message.

- [264] FIG. 18 shows a flowchart for SIP message transmission according to a third exemplary embodiment of the present invention, showing a call flow for a session negotiation between the SIP user agents A and B (900 and 1500 of FIG. 16)
- [265] Session negotiation is performed by using a SIP message including "INVITE", "100 Trying", "183 Session Progress", "PRRACK", "200 OK", and "ACK".
- [266] FIG. 18 shows an "INVITE" message exchange.
- [267] Referring to FIG. 18, the application layer gateway (ALG) (1200 of FIG. 16) receives an "INVITE" message from the SIP user agent A 900 (S501), and transmits a "100 Trying" message that is a receipt response to the "INVITE" message (S503).
- [268] The application layer gateway (ALG) 1200 performs an IP masquerading operation (S505) according to the method and the transmitting subject of the message received in the step of S501.
- [269] Since the message received in the step of S501 is an "INVITE" message, the application layer gateway (ALG) 1200 extracts the IP address and the port values specified in the m(media)/c(connection) line of the SDP included in the body of the message, inserts the extracted value instead of the header information of the "STUN Binding-Request" message for requesting global IP binding, and inserts a "Response-Address" that is set as an IP address of the application layer gateway (ALG) 900 into the "STUN Binding-Request" message.
- [270] The application layer gateway (ALG) 1200 transmits the "STUN Binding-Request" message having undergone the step of S505 to the STUN server (1400 of FIG. 16) (S507).
- [271] The STUN server 1400 performs a STUN operation (S509) by using header information of the "STUN Binding-Request" message received in the step of S507.
- [272] That is, the STUN server 1400 extracts a "Source-IP-Address" of the IP header that is passed through the NAT 1300 and is translated and a "Source-Port" in the UDP header from the "STUN Binding-Request" message, and specifies the extracted result in the "Mapped-Address" attribute of the "STUN Binding-Response" message.
- [273] The STUN server 1400 transmits a "STUN Binding-Response" to the address specified in the "Response-Address" attribute of the "STUN Binding-Request" message transmitted by the application layer gateway (ALG) 1200 (S511).
- [274] The application layer gateway (ALG) 1200 extracts the "Mapped-Address" attribute value of the "STUN Binding-Response" message received in the step of S511, and applies the extracted value to the media receiving address (m/c line) of the "INVITE" received from the SIP user agent A 900 (S513). In this instance, the media receiving address includes an IP address and a port.
- [275] In this instance, the application layer gateway (ALG) 1200 can specify the IP address of the application layer gateway (ALG) 1200 on the routing path of the "INVITE"

message.

- [276] In this instance, since the call receiving side is provided on the Internet (60 of FIG. 16), the application layer gateway (ALG) 1200 specifies the global IP address of the application layer gateway (ALG) 1200 on the routing path of the "INVITE" message.
- [277] Also, when the message is transmitted from the global network to the local network, the application layer gateway (ALG) 1200 specifies the private IP address of the application layer gateway (ALG) 1200.
- [278] The application layer gateway (ALG) 1200 transmits the "INVITE" message having undergone the step of S513 to the SIP user agent B 1200 (S515).
- [279] In this instance, the SIP user agent B 1500 transmits the "100 trying" that is a receipt response to the "INVITE" message received in the step of S515 to the application layer gateway (ALG) 1200 (S517).
- [280] Referring to FIG. 16 to FIG. 18, media receiving information included in the "SDP" message of the "INVITE" message is translated into a global IP address so as to be receivable by the Internet 60 according to the IP masquerading and the STUN binding before the "INVITE" message is transmitted in the case of signaling for a call connection.
- [281] Therefore, in the case of the protocol having a signaling stage for a call setup and a media stream stage for actually transmitting/receiving data, the media receiving information included in the session layer that is not translated by the NAT is set to be a global IP address in the earlier signaling stage to thus solve the problem of the NAT-traversal.
- [282] While this invention has been described in connection with what is presently considered to be practical exemplary embodiments, it is to be understood that the invention is not limited to the disclosed embodiments, but, on the contrary, is intended to cover various modifications and equivalent arrangements included within the spirit and scope of the appended claims.



## Claims

- [1] An interworking system for interworking between a local network for using a private IP address and a global network for using a global IP address by using network address translation (NAT), the interworking system comprising: a STUN server, provided outside the NAT, for providing global IP binding information to a private IP address having passed through the NAT; and an application layer gateway (ALG), provided on the local network, for providing media receiving address information in a private IP format included in a payload of a call connection request packet received from a call transmitting terminal to the STUN server to receive media receiving address information that is translated into a global IP format, and applying the received media receiving address information to the received call connection request packet to transmit the same to a call receiving terminal.
- [2] The interworking system of claim 1, wherein the application layer gateway (ALG) includes  
an IP masquerading performer for changing header information of a global IP binding request to be transmitted to the STUN server into media receiving address information in the private IP format;  
a STUN client performer for transmitting the global IP binding request including header information changed by the IP masquerading performer and a binding response address that is set to be an IP address of the application layer gateway (ALG) to the STUN server, and receiving a global IP binding response including the changed header information that is translated into the global IP; and  
an address translator for translating media receiving address information of the received call connection request packet into media receiving address information that is bound to be the global IP.
- [3] The interworking system of claim 2, wherein the IP masquerading performer includes:  
a header information setting module for changing a source IP address and a source port of the header information of the global IP binding request into an IP address and a port of media receiving address information in the private IP format; and  
a header checksum calculation module for recalculating a checksum of the header information by applying the changed IP address and port.
- [4] The interworking system of claim 3, wherein the application layer gateway (ALG) further includes a determiner for determining whether to drive the IP masquerading performer depending on the determination whether the network of

the destination specified in the header of the call connection request packet corresponds to a source network.

- [5] The interworking system of any one of claim 2 to claim 4, wherein the STUN server includes:  
a storage unit for storing setting information on the global IP binding request and response processing in cooperation with the application layer gateway (ALG);  
and  
a STUN performer for loading header information of the global IP binding request that is translated into the global IP through the NAT in the global IP binding response by using the setting information of the storage unit, and transmitting the header information to the application layer gateway (ALG).
- [6] An interworking method between a local network using a private IP address and a global network using a global IP address by using NAT, the interworking method comprising:  
(a) extracting media receiving address information in the private IP format from a payload of a call connection request packet received by the local network from a call transmitting terminal;  
(b) transmitting a global IP binding request in which header information is changed with the extracted media receiving address information in the private IP format;  
(c) receiving a global IP binding response including the header information that is translated into the global IP by the NAT; and  
(d) transmitting the call connection request packet that is generated by changing the media receiving address information in the private IP format into the media receiving address information that is translated into the global IP received in (c) to a call receiving terminal.
- [7] The interworking method of claim 6, wherein the (a) includes:  
checking the destination of the call connection request packet to determine whether the network of the call receiving terminal corresponds to the network of the call transmitting terminal;  
transmitting the call connection request packet to the call receiving terminal when the network of the call receiving terminal corresponds to the network of the call transmitting terminal; and  
extracting media receiving address information in the private IP format from a payload of the call connection request packet when the network of the call receiving terminal does not correspond to the network of the call transmitting terminal.
- [8] The interworking method of claim 7, wherein the (b) includes:

changing a source IP address of IP header information of the global IP binding request with a source IP address extracted from media receiving information in the private IP format; and

changing a source port of user datagram protocol (UDP) header information of the global IP binding request with the source port extracted from the media receiving address information in the private IP format.

- [9] The interworking method of claim 8, wherein the (b) includes:  
recalculating a checksum of the IP header information by applying the changed IP address value; and  
recalculating a checksum of the UDP header information by applying the changed source port value.

- [10] An application layer gateway (ALG) for routing a session initiation protocol (SIP) message so as to perform interworking between a local network using a private IP address and a global network using a global IP address, the local network configuring a node, the application layer gateway (ALG) comprising:  
a message receiver for checking a transmitting subject and a method of a received SIP message;  
a message translator for performing NAT translation on the media receiving address information of the SIP message and real time control protocol (RTCP) receiving address information based on the checked result, and adding address information of the message translator to the routing path of the SIP message; and  
a message transmitter for transmitting the SIP message translated by the message translator to the next routing path of the SIP message.

- [11] The application layer gateway (ALG) of claim 10, wherein the message translator includes:  
a SIP address allocation storage module for storing information generated by mapping the NAT pre/post translation information;  
a SIP address allocation module for allocating a global IP on the media receiving address information of the received SIP message and the RTCP receiving address information;  
a SIP address mapping module for mapping the media receiving address information of the received SIP message and the RTCP receiving address information on the SIP address information that is not allocated by the SIP address allocation module, and storing the mapped result in the SIP address allocation storage module; and  
a SIP message translation module for performing a SIP address translation by the SIP address allocation module and the SIP address mapping module, and specifying an IP address of the SIP message translation module on the routing

- path of the requested SIP message
- [12] The application layer gateway (ALG) of claim 11, wherein the SIP message translation module includes:
- a first address translation module for translating addresses of m/c/a attribute values that are extracted from the session description protocol (SDP) of the SIP message;
  - a second address translation module for translating an address of transport information of the SIP message, the transport including one of a host name or a network address of the transmitting subject; and
  - a routing path generating module for generating a routing path for the SIP service request message as a global IP or a private IP of the node according to the message transmitting subject.
- [13] A network address translator for routing a SIP message, the network address translator being provided on the boundary of a local network using a private IP address and a global network using a global IP address, the network address translator comprising:
- a packet analyzer for analyzing a received packet and checking whether the packet has a SIP message; and
  - an application layer gateway driver for performing a NAT translation on the media receiving and RTCP receiving address information by referring to a NAT translation table for the SIP message, and including address information of the application layer gateway driver in the routing path of the SIP message to route the same to the corresponding destination.
- [14] The network address translator of claim 13, wherein the application layer gateway driver includes:
- a message analysis module for analyzing a method and a message transmitting subject of the SIP message transmitted from the packet analyzer;
  - a SIP address allocation module for referring to the NAT translation table and allocating the SIP address according to the analyzed method and message transmitting subject;
  - a first message translation module for applying the address allocated by the SIP address allocation to the SIP message; and
  - a second message translation module for including a global IP address of the second message translation module in the routing path when the transmitting subject of the SIP message is a local network, and including a private IP address of the second message translation module in the routing path when the transmitting subject thereof is a global network.
- [15] The network address translator of claim 14, wherein the SIP address allocation

module includes:

an allocator for allocating the m/c/a attribute values in the SDP of the SIP message as global IP address information by referring to the NAT translation table; and

a mapper for mapping global IP address information and private IP address information of the m/c/a attribute values to configure a SIP address allocation table.

- [16] The network address translator of any one of claim 13 to claim 15, wherein the first message translation module applies the allocated global IP to transport information of the SIP message, the transport including one of a host name or a network address of the transmitting subject.
- [17] A SIP message routing method of a node for interworking between a local network using a private IP address and a global network using a global IP address, the SIP message routing method comprising:
- (a) checking a transmitting subject and a method of the received SIP message;
  - (b) applying the NAT address translation following the checked message transmitting subject and the method to the media and RTCP receiving address information of the SIP message;
  - (c) specifying the address of the node selected based on the checked message transmitting subject in routing path information of the SIP message, the routing path determining a routing path of the next request message; and
  - (d) routing the SIP message to the corresponding destination address.
- [18] The SIP message routing method of claim 17, wherein the (b) includes: extracting m/c/a attribute values in the SDP of the SIP message; and translating the extracted m/c/a attribute values into a global IP address.
- [19] The SIP message routing method of claim 17 or claim 18, wherein the (b) includes:
- translating the media and RTCP receiving address information into a global IP, mapping the global IP on the pre-translation information, and temporarily storing mapping information results when the transmitting subject is a local network and the method is a session invite request message; and
  - storing the temporarily stored mapping information in a SIP address allocation table when the transmitting subject is a global network and the method is a response message to the session invite request message.
- [20] The SIP message routing method of claim 19, wherein the (c) includes: specifying a global IP address of the node when the message transmitting subject is a local network; and specifying a private IP address of the node when the message transmitting

subject is a global network.

- [21] The SIP message routing method of claim 20, further comprising, after the (d), receiving a SIP service request message by using a private IP address of the node when the transmitting subject is a local network;  
receiving a SIP service request message by using a global IP address of the node when the transmitting subject is a global network; and  
routing the received message to the corresponding destination.
- [22] The SIP message routing method of claim 21, wherein the (b) further includes applying the NAT address translation to transport information of the SIP message, the transport including one of host name or network address information of the transmitting subject.
- [23] The SIP message routing method of claim 22, wherein the (b) includes performing the NAT address translation by using a NAT address translation table.
- [24] An interworking system for a SIP service between a local network using a private IP address and a global network using a global IP address, the interworking system comprising:  
a STUN server for providing global IP binding information of the private IP address that is translated through NAT; and  
an application layer gateway (ALG) for providing media and RTCP receiving address information in the private IP format extracted from the SIP message received from a call transmitting terminal to the STUN server to receive address information that is translated into a global IP, applying the address information to the SIP message, and transmitting an applied result to a call receiving terminal.
- [25] The interworking system of claim 24, wherein the application layer gateway (ALG) further includes a proxy performer for performing a proxy function of the SIP message.
- [26] The interworking system of claim 24 or claim 25, wherein the application layer gateway (ALG) further includes a determiner for checking a transmitting subject and a method of the received SIP message to determine whether the network of the call transmitting terminal corresponds to the network of the call receiving terminal and whether the SIP message is a request message or a response message.
- [27] The interworking system of claim 26, wherein the application layer gateway (ALG) includes:  
an IP masquerading performer for changing header information of a global IP binding request to be transmitted to the STUN server with m/c/a attribute values extracted in the SDP of the SIP message according to a determination by the

- determiner, the m/c/a attribute values being the media and RTCP receiving address information;
- a STUN client performer for transmitting the global IP binding request with header information changed by the IP masquerading performer to the STUN server, and receiving a global IP binding response with the changed header information bound by the global IP; and
- a message translator for acquiring the m/c/a attribute values translated into the global IP from the changed header information received by the STUN client performer, and applying the m/c/a attribute values to the received SIP message.
- [28] The interworking system of claim 27, wherein the message translator specifies one of the global IP address and the private IP address of the message translator selected based on the transmitting subject of the SIP message determined by the determiner in routing path information of the SIP message, the routing path determining a routing path of the next request message.
- [29] The interworking system of claim 28, wherein the IP masquerading performer changes a source IP address and a source port of header information of the global IP binding request with m/c/a attribute values of the received SIP message.
- [30] A SIP message routing method of a node for interworking between a local network using a private IP address and a global network using a global IP address, the SIP message routing method comprising:
- (a) transmitting a global IP binding request with changed header information to media and RTCP receiving address information in the private IP format extracted from the SIP message received from a call transmitting terminal;
  - (b) receiving a global IP binding response including the header information translated into a global IP; and
  - (c) applying the media and RTCP receiving address information translated into a global IP acquired from header information of the global IP binding response to the received SIP message, and transmitting an applied result to a call receiving terminal.
- [31] The SIP message routing method of claim 30, wherein the method includes, before the (a):
- receiving the SIP message from the call transmitting terminal;
  - checking a transmitting subject and a method of the received SIP message; and
  - determining whether the networks of the transmitting subjects of the received SIP message correspond to each other and whether the message is a request message or a response message.
- [32] The SIP message routing method of claim 31, wherein the (a) includes: extracting m/c/a attribute values in the SDP of the SIP message when the

networks of the transmitting subjects of the SIP message are different and the message is a session request message, the m/c/a attribute values being the media and the RTCP receiving address information; and changing the header information of the global IP binding request with the extracted m/c/a attribute values.

[33] The SIP message routing method of claim 32, wherein the (a) includes: extracting the m/c/a attribute values in the SDP of the SIP message when the networks of the transmitting subjects of the SIP message are different and the message is a session invite request message; and changing the source IP address and the source port of header information of the global IP binding request with the extracted m/c/a attribute values.

[34] The SIP message routing method of any one of claim 30 to claim 33, wherein the (c) includes: changing the media and RTCP receiving address information included in the received SIP message with the media and RTCP receiving address information translated into the global IP; selecting one of the global IP address and the private IP address selected based on the transmitting subject of the SIP message determined by the determiner; specifying the selected IP address in routing path information of the changed SIP message, the routing path determining a routing path of the next request message; and transmitting the SIP message in which the changed media, the RTCP address, and the routing path are specified.



[Fig. 1]

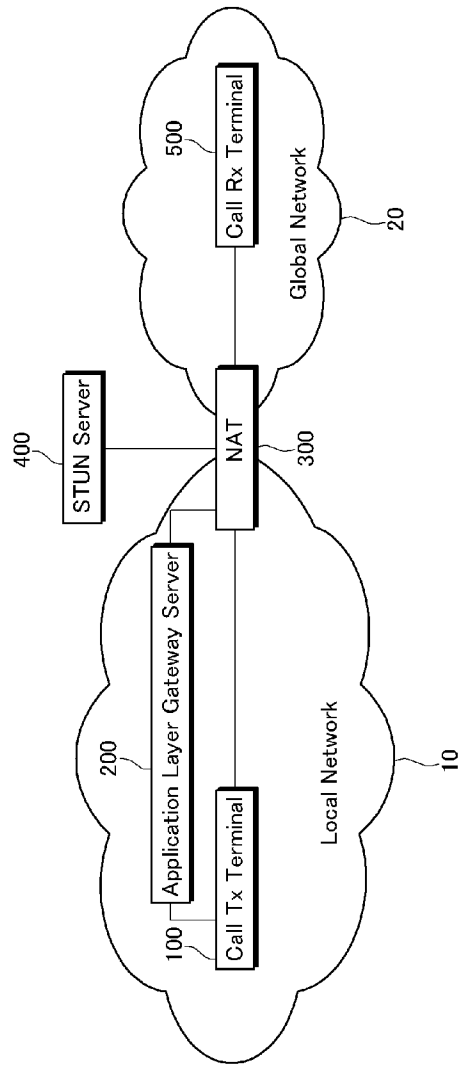

[Fig. 2]

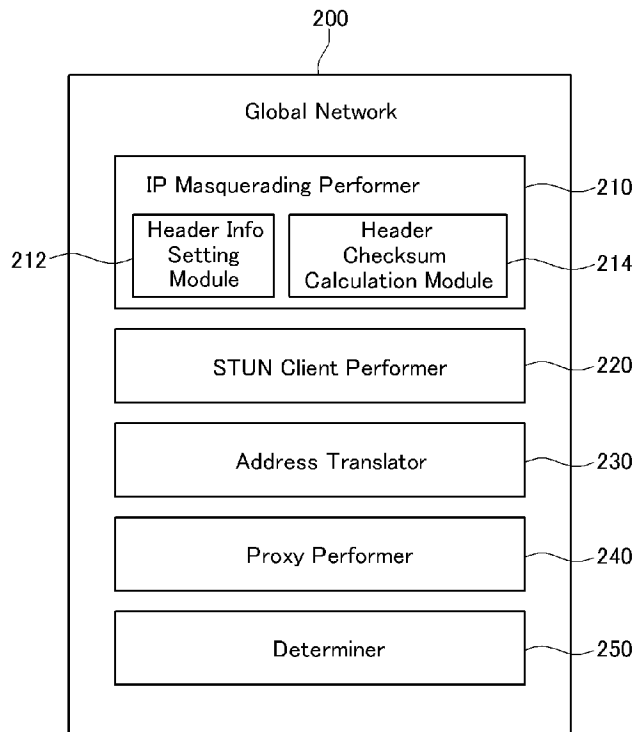

[Fig. 3]

Version	IHL	TOS	Total Length	
ID		Flag	Fragment Offset	
TTL	Protocol	Header Checksum (→ Recalculate)		
Source IP Address (→ Call Tx UE IP Address)		P101		
Destination IP Address		P103		

[Fig. 4]

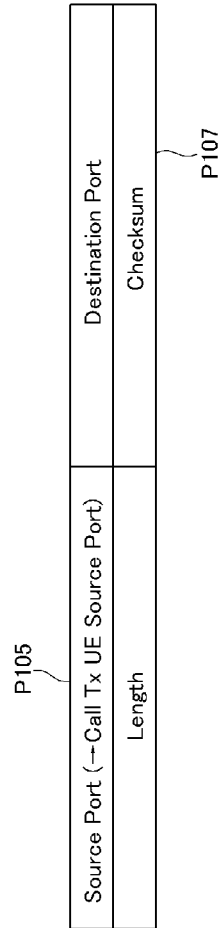

[Fig. 5]

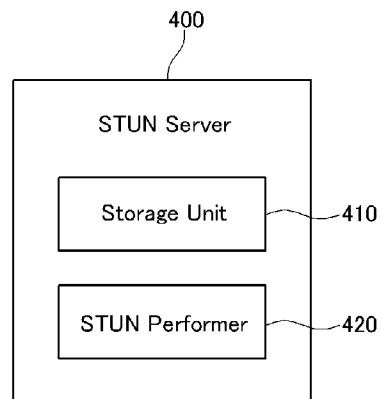

[Fig. 6]

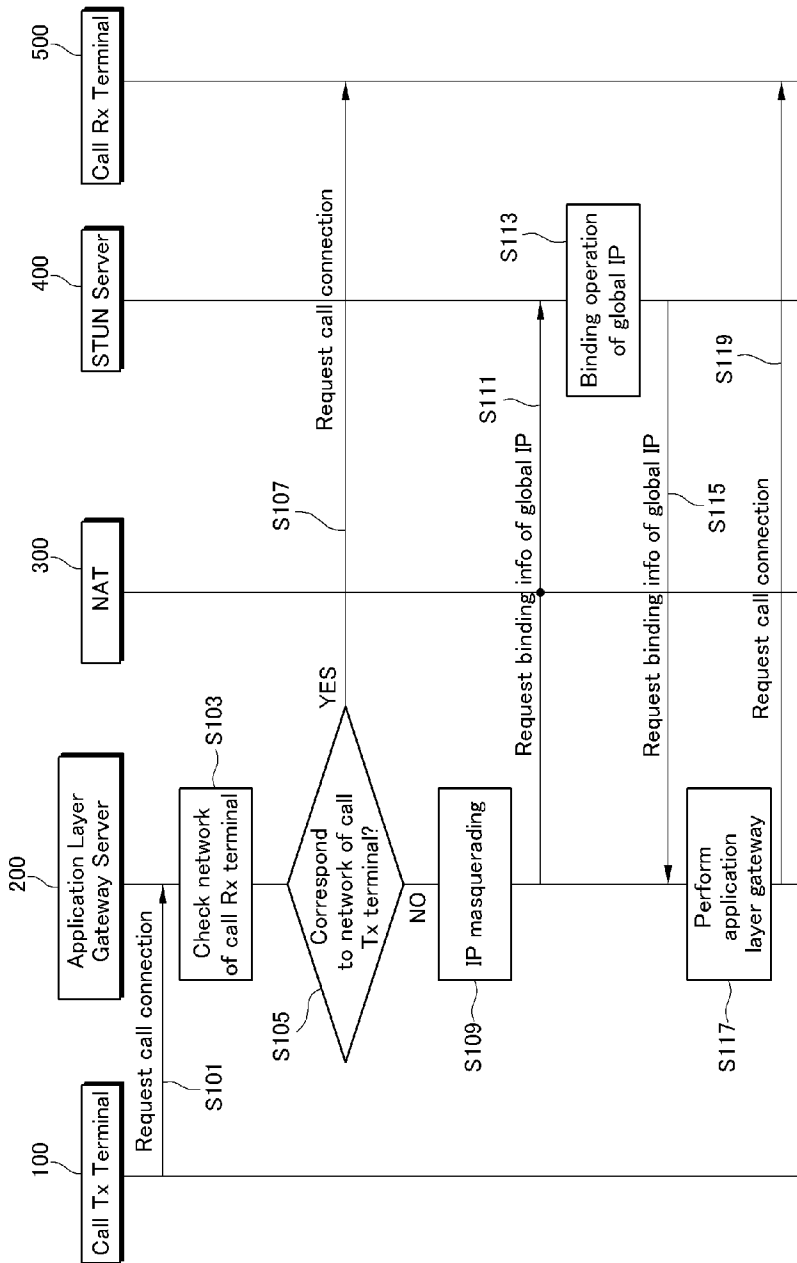

[Fig. 7]

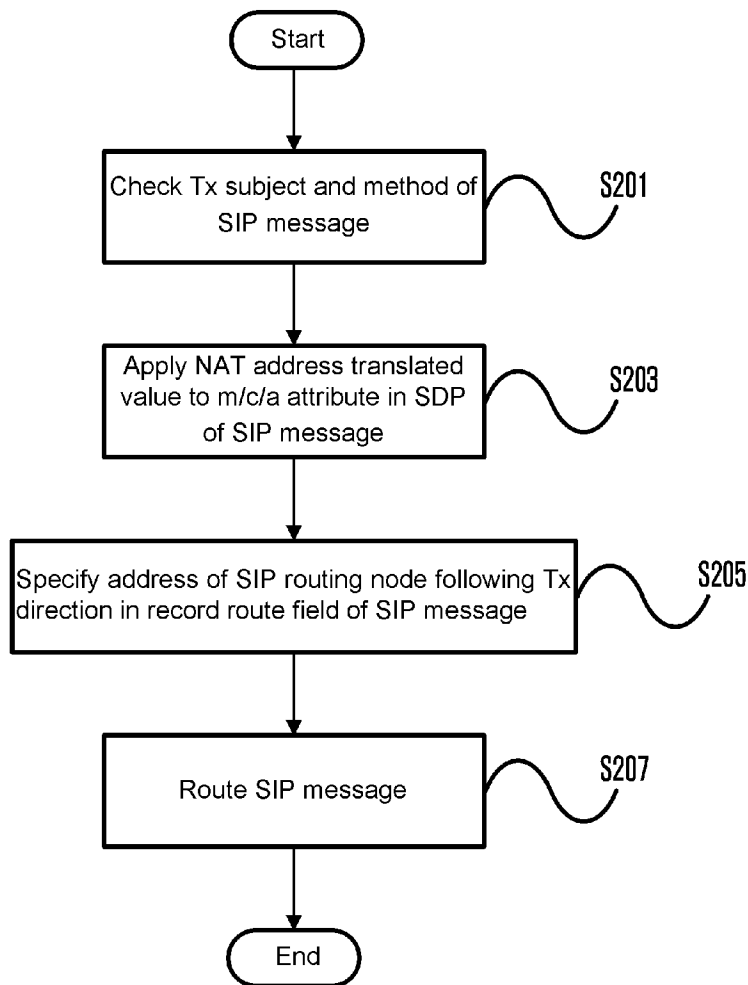

[Fig. 8]

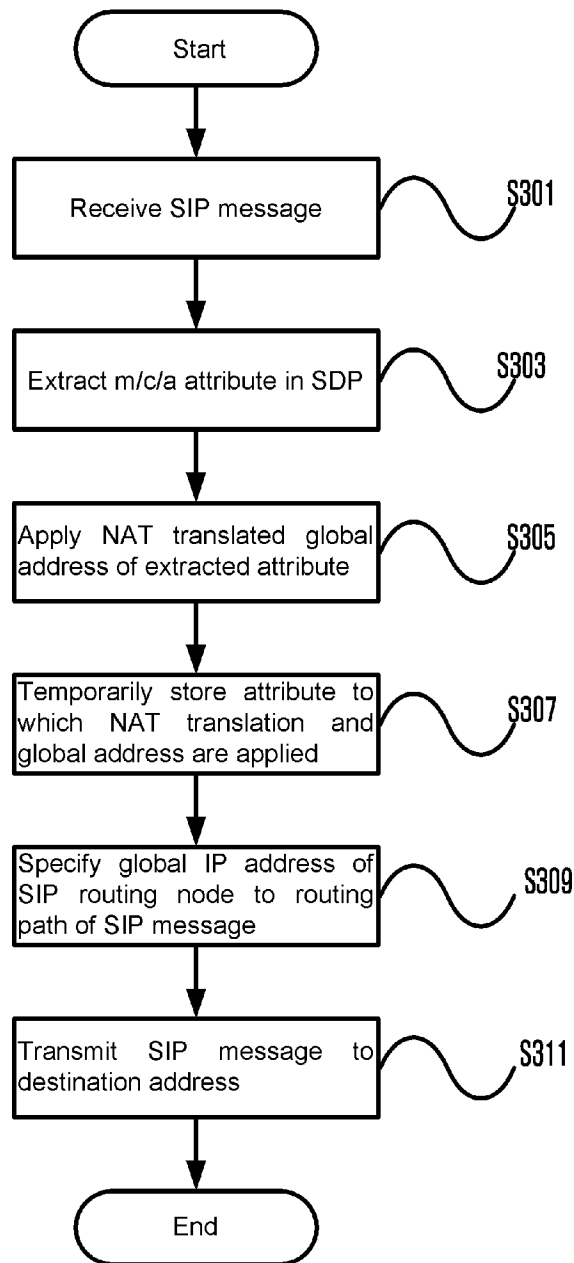



[Fig. 9]

Type	Call Tx	Call Rx	ALG translation applying message
P201 ~ Case(1)	Private	Public	INVITE
P203 ~ Case(2)	Public	Private	200 OK (for INVITE)

[Fig. 10]

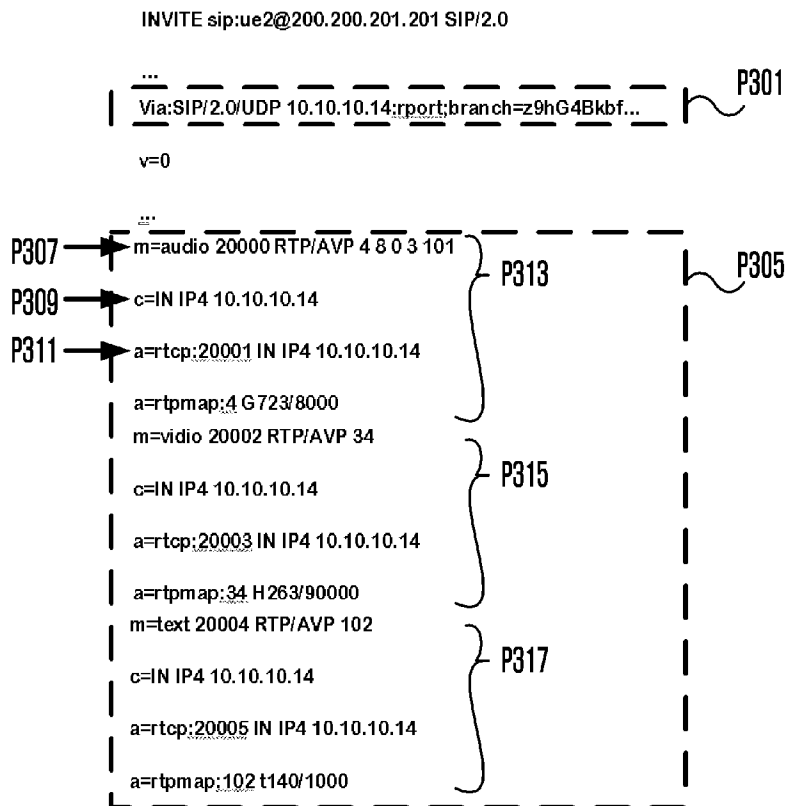

[Fig. 11]

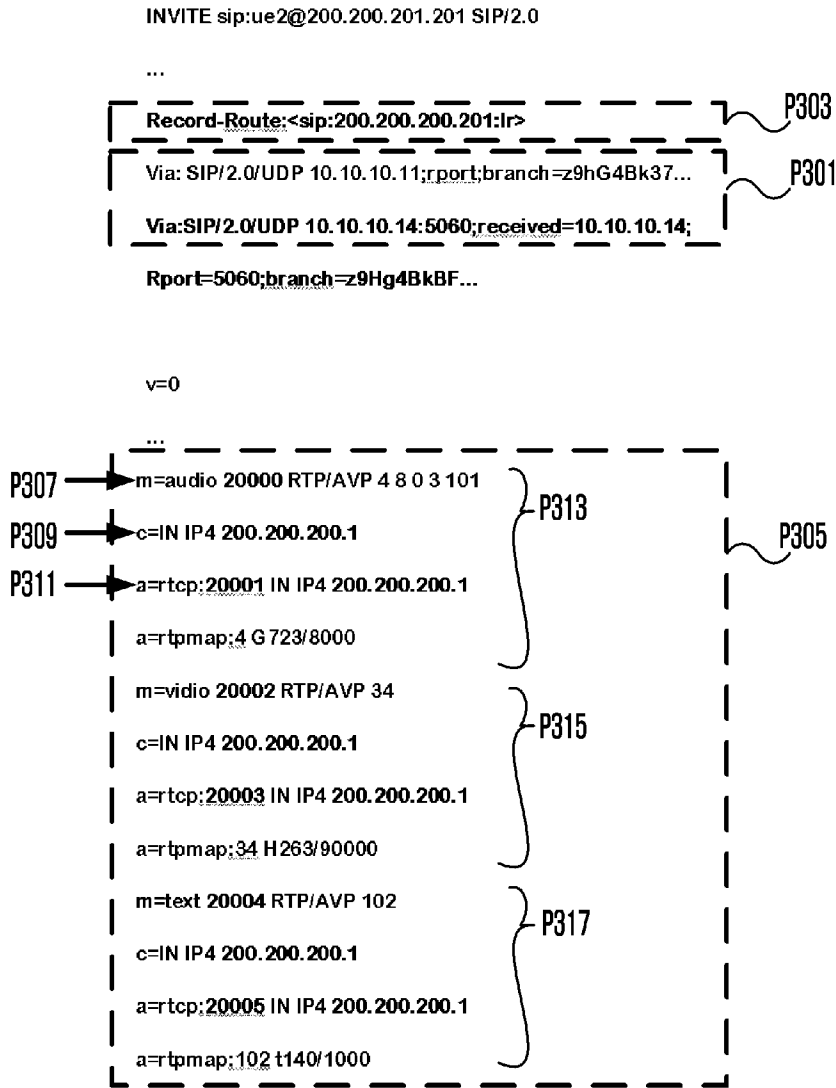

[Fig. 12]

Type	Call Tx	Call Rx	Adfd
P201 ~ Case(1)	Private	Public	INVITE
P203 ~ Case(2)	Public	Private	200 OK (for INVITE)

[Fig. 13]

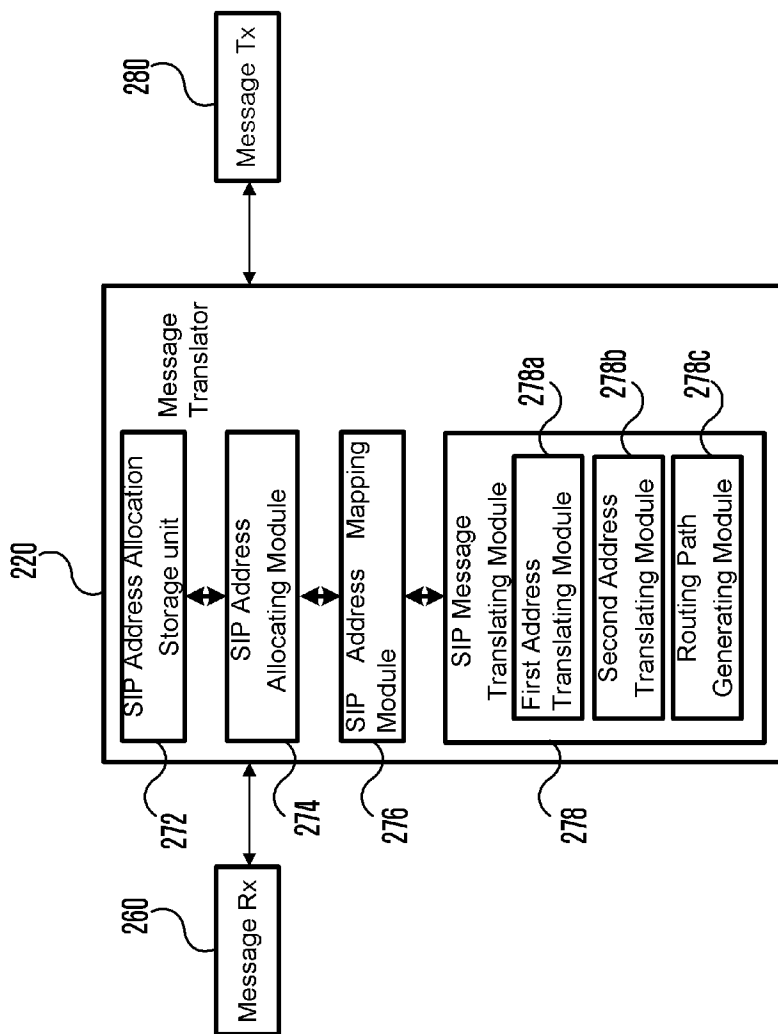

[Fig. 14]

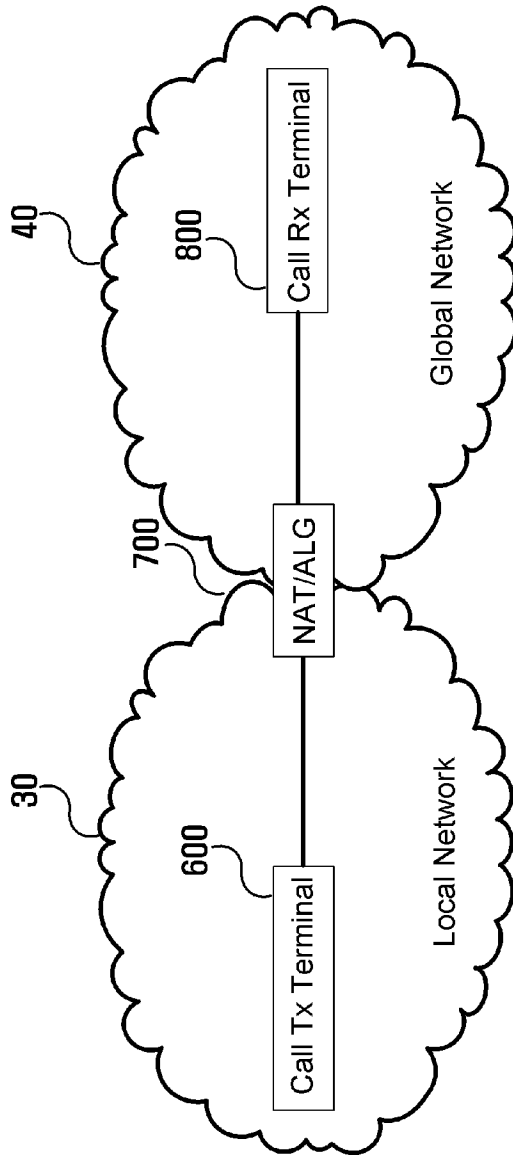

[Fig. 15]

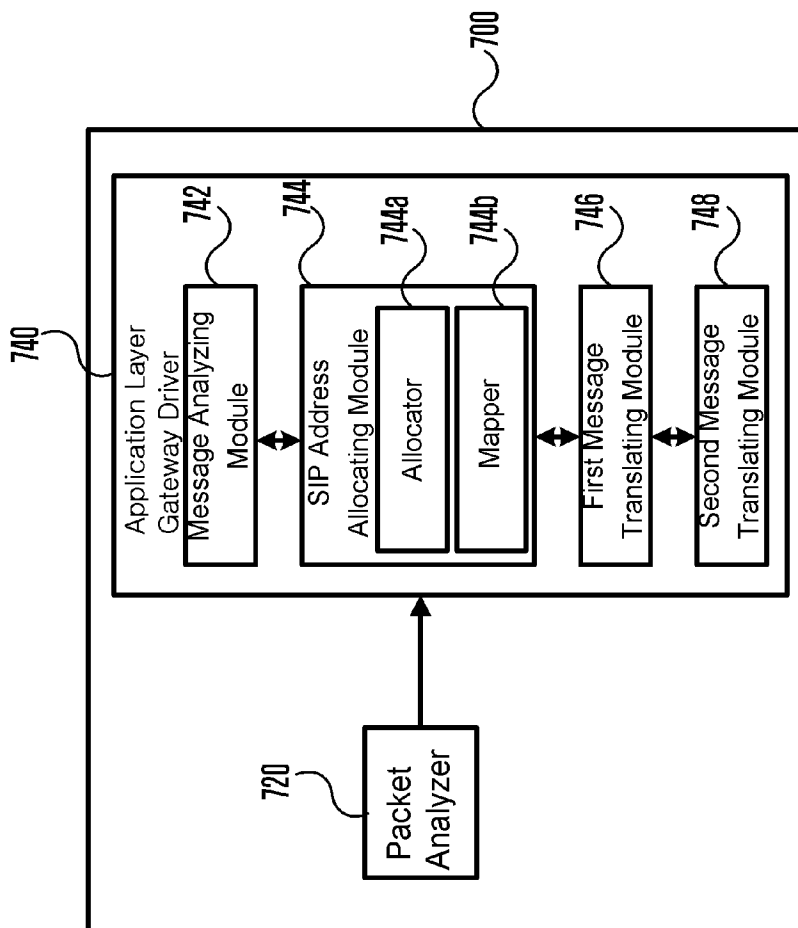

[Fig. 16]

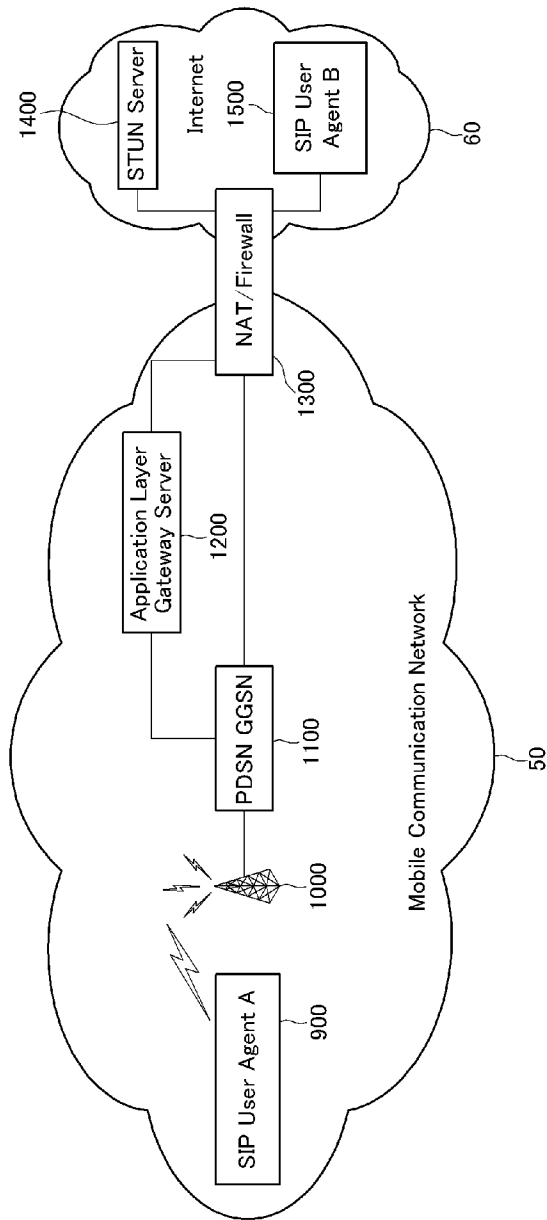



[Fig. 17]

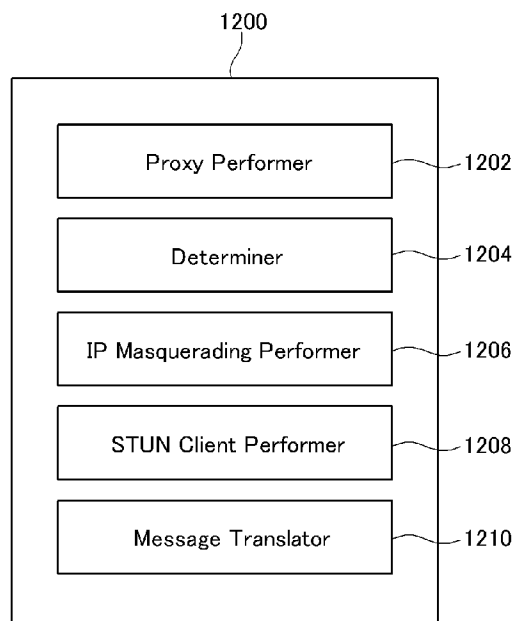

[Fig. 18]

