

(12) UK Patent Application (19) GB (11) 2 317 008 (13) A

(43) Date of A Publication 11.03.1998

(21) Application No 9618621.8

(22) Date of Filing 06.09.1996

(71) Applicant(s)  
British Aerospace Public Limited Company  
(Incorporated in the United Kingdom)

PO Box 87, Warwick House, Farnborough  
Aerospace Centre, FARNBOROUGH, Hants,  
GU14 6YU, United Kingdom

(72) Inventor(s)  
Alan Richard Malvern

(74) Agent and/or Address for Service  
British Aerospace Public Limited Company  
PO Box 87, Corporate Intellectual Property Dept,  
Lancaster House, Park East, Farnborough  
Aerospace Centre, FARNBOROUGH, Hants,  
GU14 6YU, United Kingdom

(51) INT CL<sup>6</sup>  
G01B 11/16

(52) UK CL (Edition P)  
G1A AA3 AA5 ACEF AG16 AG18 AR7 AT3 AT5  
U1S S1839

(56) Documents Cited  
GB 222247 A EP 0727640 A2

(58) Field of Search  
UK CL (Edition O ) G1A ABF ACEF  
INT CL<sup>6</sup> G01B 9/02 11/16 , G01L 1/24  
Online: WPI

(54) A fibre optic interferometric strain gauge assembly

(57) A fibre optic interferometric strain gauge assembly includes a sensor element (1) in the form of a length of single mode optical fibre whose ends (1a) and (1b) have a peak reflectivity not exceeding 10%. This reflectivity is provided either by semi-transparent coatings on the fibre ends or by the establishment of Bragg gratings within the fibre length. A laser source (2) provides a beam which is coupled into the element (1) as one arm of an interferometer. The light reflected in the interferometer whose intensity varies depending upon the degree of strain applied to the element (1) is detected and separated out into samples corresponding to the frequency of the laser source and to twice the frequency of the laser source with the two values being processed to provide both the magnitude of strain and the direction of strain in the element (1), which are derived from the ratio of intensity values for the two frequency components.

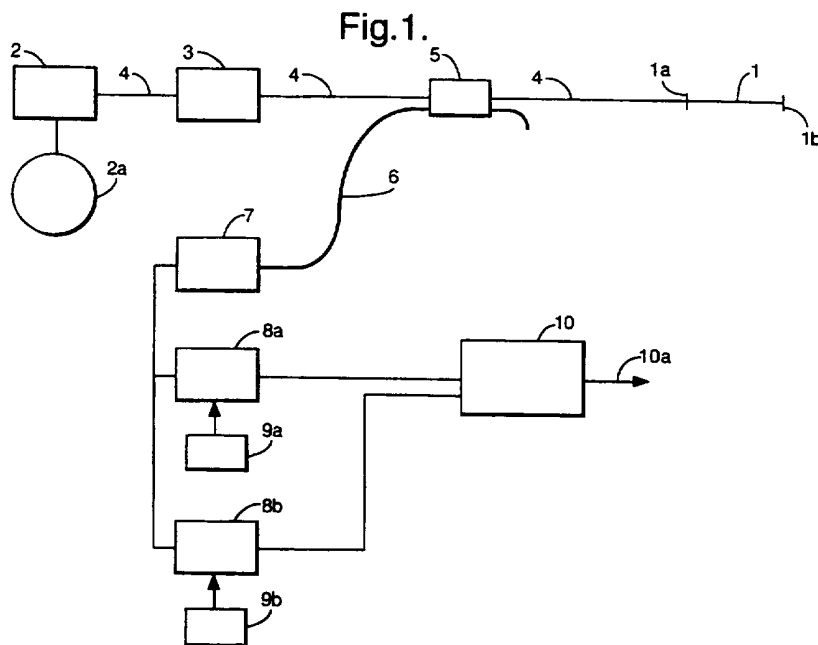

GB 2 317 008 A

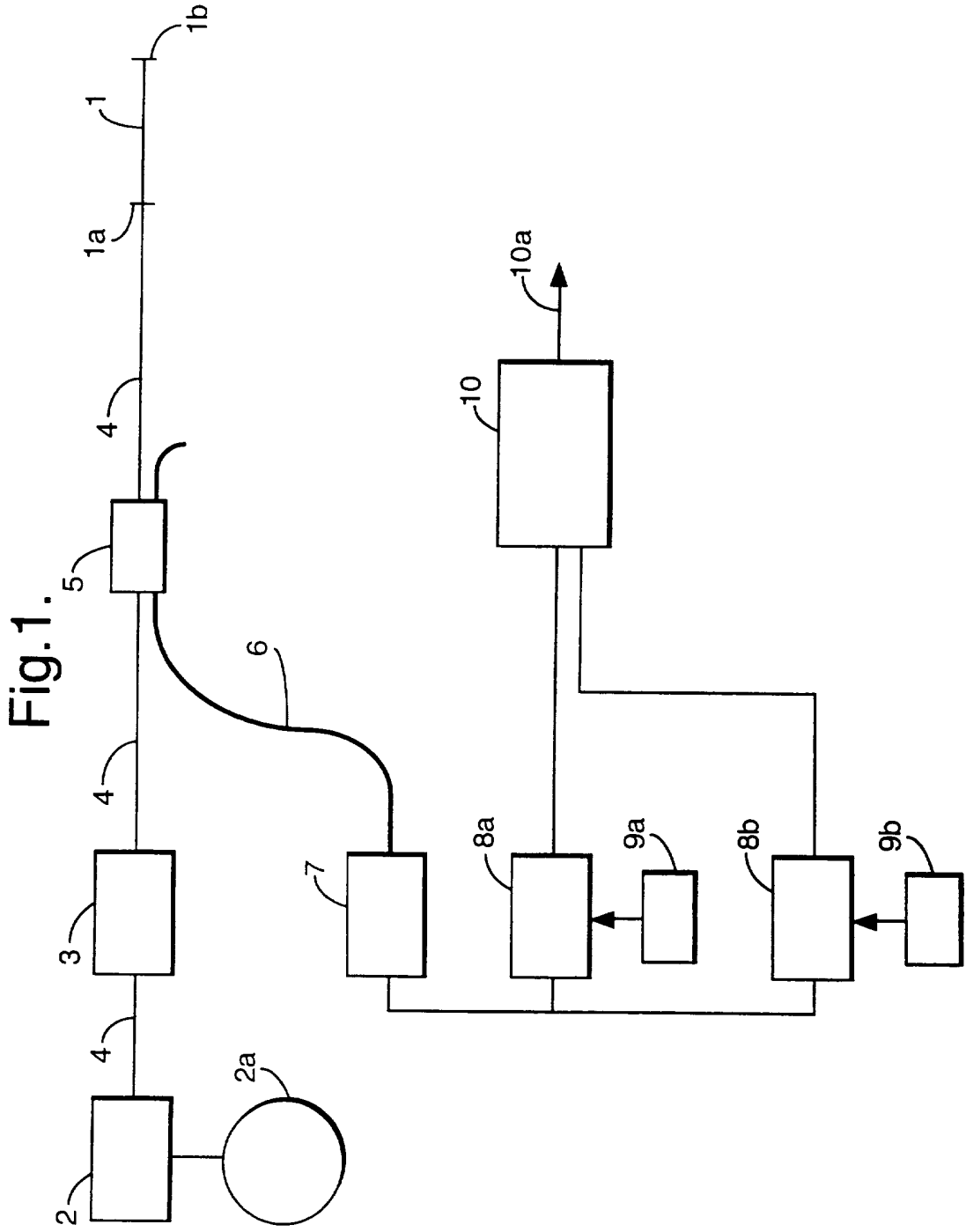

Fig.2.

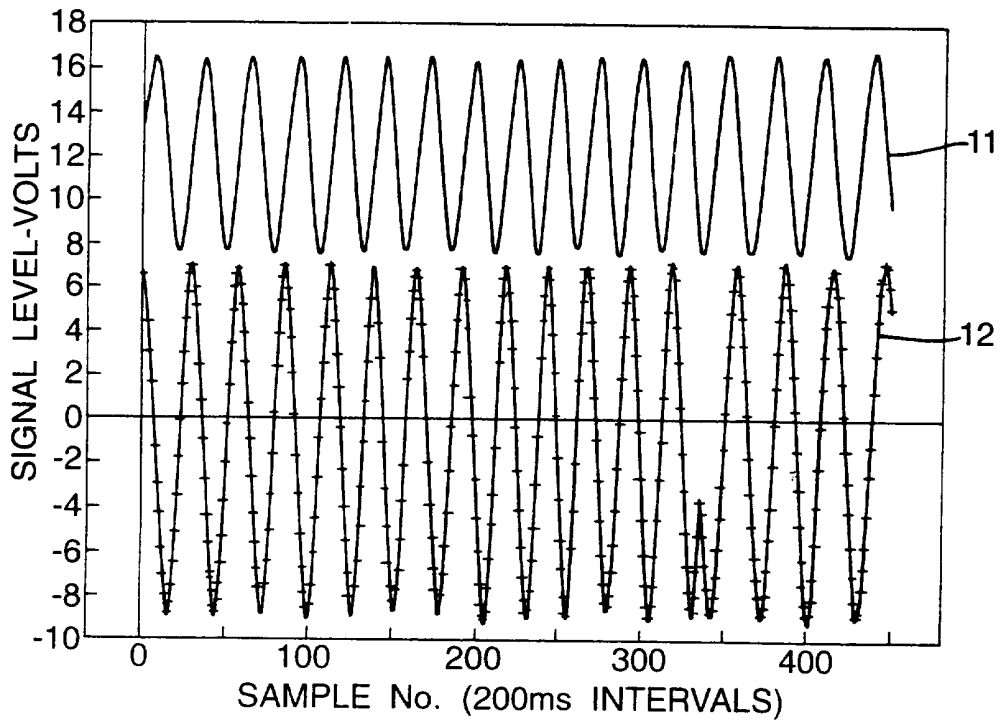

Fig.3.

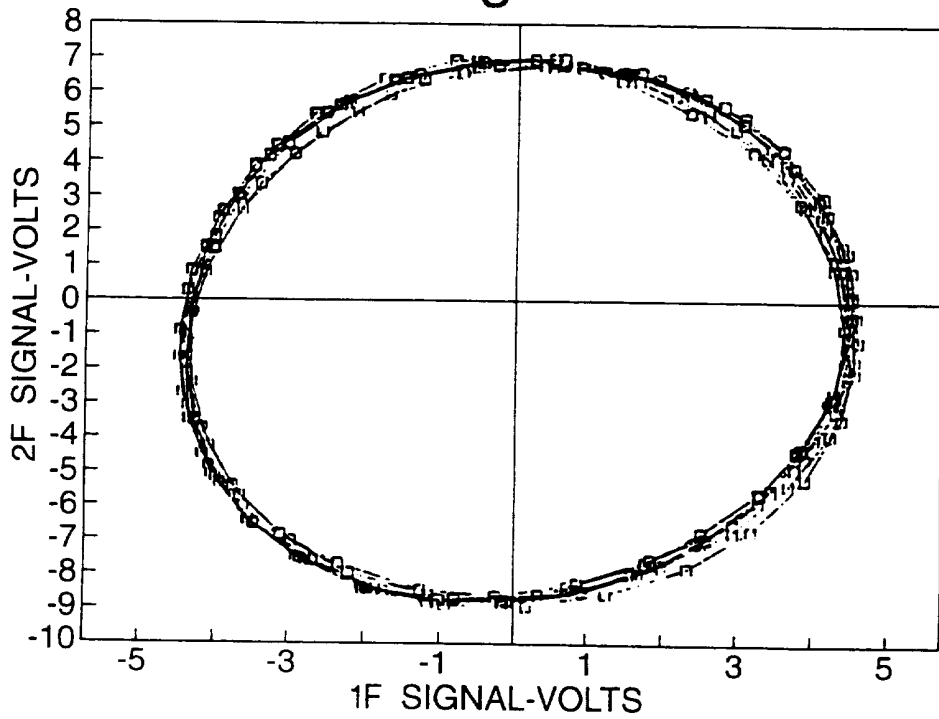
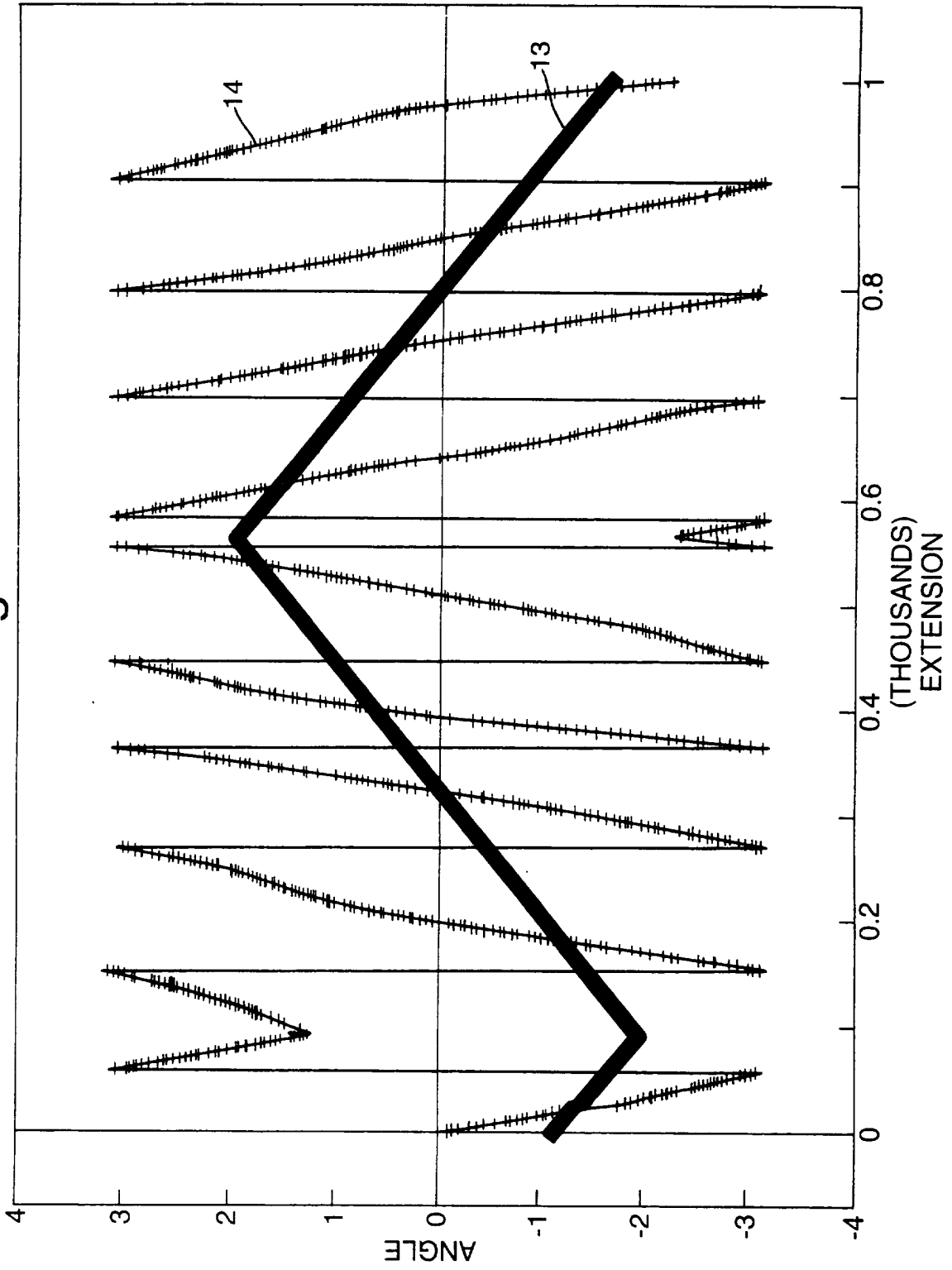

Fig.4.



**A FIBRE OPTIC INTERFEROMETRIC STRAIN GAUGE ASSEMBLY**

This invention relates to a fibre optic interferometric strain gauge assembly suitable particularly, but not exclusively, for testing structures and for fatigue monitoring systems in aircraft.

Conventional electrical strain gauges require a relatively large number of electrical lead outs which increases the weight and expense. Additionally such conventional electrical strain gauges are subject to electromagnetic noise which can give rise to false or distorted readings. This makes such conventional gauges relatively unsatisfactory for use on aircraft either as the retrofit assembly or as part of a composite panel assembly. Moreover in an aircraft application the use of electrical cables means that they can be damaged by lightning strikes with consequent reduction in reliability and life of the strain gauge assembly.

There is thus a need for a generally improved strain gauge assembly which at least minimises the foregoing disadvantages inherent in conventional electrical strain gauges.

According to the present invention there is provided a fibre optic interferometric strain gauge assembly including a sensor element in the form of a length of single mode optical fibre whose ends have a peak reflectivity not exceeding ten percent, means for generating and passing a beam of light with a single longitudinal mode into the sensor element where interference takes place in the light reflected between the

fibre ends, such that a change in length of the sensor element resulting from strain thereon produces a change in intensity of the reflected light, and means for receiving and processing the reflected light to establish light intensity values at one ( $1f$ ) and two times ( $2f$ ) the frequency ( $f$ ) of the light generating source, and to establish from the ratio of the intensity values  $1f: 2f$  and direction and magnitude of the strain on element.

Preferably the means for generating and passing a beam of light into the sensor element includes a semiconductor laser, a non-return isolator for receiving the beam of light from the laser and a coupler for receiving the light beam from the isolator and passing it into the sensor element.

Conveniently the coupler is operable to split the received light beam into two sub-beams one of which is passed directly into the sensor element via a single mode optical fibre, and to receive from the sensor element the light reflected from the sensor element.

Advantageously the means for receiving and processing the reflected light includes a photodetector for receiving the reflected light from the coupler, two lockin detectors operable to sample the reflected light output from the photodetector, one at a frequency of  $1f$  and the other at a frequency of  $2f$ , and demodulate the samples at these two frequencies and means for logging the demodulated samples and for establishing the inverse tangent of the ratio of the intensity values  $1f: 2f$  to extract an interferometer phase to

determine the direction and magnitude of the strain on the sensor element.

Preferably the ends of the sensor element fibre are coated to provide the internal peak reflectivity not exceeding 10% and to give a Fabry Perot optical configuration to the sensor fibre.

Conveniently the coated ends are provided by a coating of titanium dioxide.

Advantageously the coated ends are separated by a distance in the range of from 5 to 50mm.

Alternatively the peak reflectivity not exceeding 10% within the sensor element is provided by a Bragg grating at each end of the sensor element fibre which produce in the sensor element a Fabry Perot etalon.

Conveniently the assembly includes means for generating two ultraviolet laser beams and for shining them at oblique angles of incidence to impinge at the same position within the sensor element fibre to generate a set of interferometric fringes to provide the Bragg gratings.

Advantageously the means for generating two ultraviolet laser beams includes a phase grating operable to provide the two obliquely angled beams from a single laser source.

Preferably the assembly includes means for varying the pitch of the Bragg gratings along the length of the gratings to reduce the Bragg grating peak reflectivity to not more than 10% and to increase the Bragg grating reflectance band width to a range of from 10 to 30 nanometers.

For a better understanding of the present invention, and to show how the same may be carried into effect, reference will now be made, by way of example, to the accompanying drawings in which:

Figure 1 is a schematic block diagram of a fibre optic interferometric strain gauge assembly according to a first embodiment of the present invention,

Figure 2 is a graphical representation of signal level plotted against sample number for output signals at two specific frequencies in the assembly of Figure 1 as a function of strain applied to a sensor element of the assembly,

Figure 3 is a graphical representation of the two output signals of Figure 2 plotted against each other to form a Lissajou figure, and

Figure 4 is a graphical representation of phase angle showing the phase angle plotted against the extension in thousands of a millimetre of the sensor element of the assembly of Figure 1 resulting from strain applied thereto.

The strain gauge assembly of the present invention is a fibre optic interferometric strain gauge assembly. Such an assembly according to a first embodiment of the invention is shown schematically in Figure 1 of the accompanying drawings. This fibre optic strain gauge is passive with a dielectric lead out and with a fibre optic connection. As a result it is not sensitive to lightning strikes and no power is consumed at a sensor element in the assembly. This gives rise to excellent life properties and substantially complete



resistance to lightning strikes and to other sources of interference.

Thus a fibre optic interferometric strain gauge assembly of the present invention as shown schematically in Figure 1 includes a sensor element 1 in the form of a length of single mode optical fibre whose ends 1a and 1b have a peak reflectivity not exceeding 10%. The assembly also includes means for generating and passing a beam of light with a single longitudinal mode into the element 1 where interference takes place in the light reflected between the fibres ends 1a and 1b such that a change in length of the sensor element resulting from strain thereon produces a change in intensity of the reflected light. Also forming part of the assembly of the present invention is means for receiving and processing the reflected light to establish light intensity values at one ( $1f$ ) and two times ( $2f$ ) the frequency ( $f$ ) of the light generated by the means for generating the beam of light and to establish from the ratio of the intensity values  $1f:2f$  the magnitude and direction of the strain on the element 1.

The means for generating and passing a beam of light into the sensor element 1 includes a light generating source 2 preferably in the form of a semiconductor laser provided with a current supply drive 2a operable provide an injection current to the laser modulated at a frequency  $f$  which causes the frequency of the laser light to be modulated at the frequency  $f$ . Also forming part of this means are a non-return isolator 3 for receiving the beam of light from the laser 2 via an optical fibre 4 and a coupler 5 for receiving the light

beam from the isolator 3 and passing it into the sensor element 1 via a further length of optical fibre 4. Preferably the optical fibre 4 is a single mode fibre into which the light from the laser 2 is passed having a typical wavelength of 820 nm. Alternatively the optical fibre 4 could be a telecommunication grade fibre operable at wavelengths of 1.3 micron and 1 micron. The laser 2 is required to have a single longitudinal mode to ensure sufficient coherence length for the interference to occur between the ends 1a and 1b of the element 1.

The coupler 5 is a 50/50 coupler which splits the light beam in the fibre 4 into two sub-beams one of which is passed directly into the sensor element 1 via the single mode optical fibre 4.

According to one embodiment of the present invention the sensor element 1 is in the form of a length of optical fibre, typically between 5 and 10 cm in length on which the ends 1a and 1b are coated, such as with titanium dioxide deposited thereon by sputtering, to provide the semitransparent mirror coating having an internal peak reflectivity not exceeding 10%. This level of reflectivity is necessary to give a reflected spectrum of light with a sine wave variation and is in essence a Fabry Perot etalon with a very low finesse, typically of about 1. The semitransparent ends 1a and 1b of the element 1 can be formed by coating the full length of the fibre with titanium dioxide with a quarter wave layer with a high refractive index of 2.3. The coated end 1a of the element 1 is then carefully fusion spliced to the end of the

adjoining fibre 4. Conveniently the distance between the two ends 1a and 1b of the element 1 is in the range 5 to 50mm.

The coupler 5 is also operable to receive from the sensor element 1, the light reflected therefrom and to pass this via an optical fibre 6 to a photodetector 7 which is preferably a InGaAs PINFT photodetector/preamp, commonly used in telecommunications, with a typical transimpedance of 60,000. Such a photodetector forms part of the means for receiving and processing the reflected light. Also forming part of these means are two lockin detectors 8a and 8b operable to sample the reflected light output from the photodetector 7. The detector 8a detects the amount of reflected light at a frequency of  $1f$  and the detector 8b detects the amount of reflected light at a frequency of  $2f$  with both detectors 8a and 8b demodulating the samples at these two frequencies. The frequency  $1f$  is the operating frequency ( $f$ ) at which the laser 2 is driven by the laser drive 2a and this is conveniently 10kHz.

Thus the drive 2a operates at an AC current modulation optically 1mA peak at the frequency of 10kHz. This gives rise to a frequency modulation of the laser 2 of about  $\pm 1$ GHz which causes a modulation of the intensity of the reflected light in the element 1 as the response of the sensor element 1 is scanned by the AC current. This is due to the interference effect of the etalon formed by the element 1 which can occur either by varying the wavelength of the laser 2 or by changing the length of the fibre of the element 1. Thus the detector 8a detects the amount of reflected light of frequency  $1f$  which

is the same as the drive frequency of the laser 2 using a frequency reference 9a whilst the detector 8b detects the amount of reflected light at the frequency  $2f$  which is 20kHz using a frequency reference 9b of  $2f$ . The laser drive frequency  $1f$  is used as a reference for 9a.

The assembly also includes means 10 for logging the demodulated samples received from the detectors 8a and 8b and for establishing the inverse tangent of the ratio of the intensity values  $1f:2f$  to extract an interferometer phase at the output 10a from the means 10 to determine the direction and magnitude of the strain on the element 1. The amount of reflected light at frequencies  $1f$  and  $2f$  varies like a sine and cosine wave respectively in going through an interference cycle and it is therefore feasible to determine where on the fringe pattern as shown in Figure 2 or Figure 4 the interferometer is after the two signals are logged. The output signals from the detectors 8a and 8b determine whether the phase is rising or falling so that the interferometer is sensitive to direction. If the length of the interferometer, that is of the element 1, changes by a half a wavelength of light which is typically 1.3 micron, then a complete cycle of interference occurs. When a complete fringe has been gone through there is a  $2\pi$  jump in phase so that the phase can be continuously tracked through a number of complete fringes.

The theory of the assembly shown in Figure 1 is as follows. When interference occurs within the element 1 and the reflected light is returned to the coupler 5 and from thence to the photodetector the light that is passed by the

coupler towards the laser 2 is trapped in the isolator 3 so that it does not couple back to the laser 2 and affect the laser intensity.

The current on the laser 2 is modulated at a frequency  $f$  which is typically 10kHz. If this is correctly chosen there is only a very small intensity change but a large frequency change of the laser. Typically semi conductor lasers scan at 1GHz per mA drive current change. For the element 1 the reflected intensity can be shown to be:

$$I = \frac{I_0}{1 + F \sin^2 \frac{(\nu - \nu_0)}{\Delta\nu}} \quad . . . . . (1)$$

where  $\Delta\nu$  is the linewidth of the resonance  
 $I_0$  is the incident intensity,  
 $\nu - \nu_0$  is the detuning, and  
 $F$  is the finesse of the etalon (typically  
approximately 1)

The reflected light at the photodetector 7 is sampled at  $1f$  and  $2f$ , and demodulated at these two frequencies by the use of two lockin detectors 8a and 8b which include low pass filter stages to filter out unwanted frequency components. The  $1f$  and  $2f$  signals sample the first and second derivatives of the signal intensities given in equation 1 above. The intensity versus tuning of the laser given by equation 1 has a rough cosine function with a period given by  $\lambda/(2n)$ , where  $\lambda$  is the wavelength of light and  $n$  is the

refractive index of the fibre. The 1st and 2nd derivatives have sine and cosine responses respectively for low finesses of the element 1 which is set by the low reflectivity of the reflective coated ends 1a and 1b. Thus the output of the two detectors 8a and 8b can be used for up/down fringe counting, so that fringe following of the interference can be effected. This is shown in Figure 2 which shows the 1f and 2f output signals respectively 11 and 12 as a function of strain applied to a piezo used to stretch the element, which clearly shows the out of phase nature of the two signals. Also shown is the Lissajou figure in Figure 3, where the 1f is plotted against the 2f for the x and y axes respectively. Figure 4 shows the applied voltage on the piezo used to stretch the element 1 as the line 13 plotted over the effective phase of the 1f/2f signals shown by the line 14, taken with an arctangent i.e.

$$\phi = \text{atan} \frac{I_1}{I_2} \quad . \quad . \quad . \quad . \quad (2)$$

where  $I_1$  is the 1st harmonic, and

$I_2$  is the 2nd harmonic

The strain is extracted as a position on the phase line 11 with the direction being also shown by locating on the line 11 as the extracted phase angle is proportional to the strain.

This shows that the phase can be extracted to good accuracy (say 5 degrees) which corresponds to  $5/360 * (\lambda/2)$  nm, where  $\lambda$  is the wavelength of the semiconductor laser light, which is typically 1.3 microns.

According to an alternative aspect of the present invention the sensor element 1 is such that the peak

reflectivity not exceeding ten percent is provided by a Bragg grating at each end 1a and 1b to produce a Fabry Perot etalon instead of the coated semi transparent end construction of the element 1 as previously described.

The advantage of the fibre Bragg gratings is that the fibre does not need to be broken to form the gratings. The jacket of the fibre is removed, and then ultra violet light at about 260nm is shone normal to the fibre axis to generate fringes within the fibre core that are spaced about half a wavelength apart along the axis of the fibre element 1. This is achieved by shining two UV laser beams with an oblique angle of incidence to the same place within the fibre to generate a set of suitable fringes. Other technique involve the use of a phase plate, which is a phase grating giving rise to oblique diffracted beams from a single laser beam which has the same effect as two separate oblique laser beams.

A fibre Bragg grating requires to be chirped to give a reflectance bandwidth of about 10-30nm with a peak reflectance of 10%. Normally the Bragg gratings have a peak reflectance of 90% with a bandwidth of 0.1nm. The chirping is achieved by varying the grating pitch along the length of the grating. A typical length of grating is 2mm, so that one end of the grating will correspond to one end of the reflectance and the other end with correspond to one end of the reflectance and the other end will be 10nm away. There are several techniques for achieving a chirped grating. One is to use a lens for one of the two oblique bemas onto the fibre such that there is a curvature of the wavefront, giving interference

fringes of varying pitch along the length of the grating. For the Bragg grating the peak reflectivity is set at the wavelength of the laser 2. The same theory as described in connection with the coated element ends 1a, 1b applies to the Bragg grating alternative.

This signal processing technique for a fibre Fabry Perot gives direction sensing of the fringes, very accurate strain extraction to a small fraction of a fringe and offers high accuracy for extracting the fringe phase. This in turn leads to high accuracy for the fibre strain gauge assembly down to micro strain accuracy.

The basic interferometer is not an absolute gauge, in that if the power is switched off in general the particular fringe element 1 order will not be known. This can be overcome by using a short element 1, so that the fringe order is always known and the total movement is less than a single fringe over the operating strain range ( $\pm 0.5\%$ ). This is a low cost scheme.



**CLAIMS**

1. A fibre optic interferometric strain gauge assembly including a sensor element in the form of a length of single mode optical fibre whose ends have a peak reflectivity not exceeding ten percent, means for generating and passing a beam of light with a single longitudinal mode into the sensor element where interference takes place in the light reflected between the fibre ends, such that a change in length of the sensor element resulting from strain thereon produces a change in intensity of the reflected light, and means for receiving and processing the reflected light to establish light intensity values at one ( $1f$ ) and two times ( $2f$ ) the frequency ( $f$ ) of the light generated by the means for generating the beam of light, and to establish from the ratio of the intensity values  $1f:2f$  the direction and magnitude of the strain on the element.

2. An assembly according to claim 1, wherein the means for generating and passing a beam into the sensor element includes a light generating source in the form of a semiconductor laser, a non-return isolator for receiving the beam of light from the laser and a coupler for receiving the light beam from the isolator and passing it into the sensor element.

3. An assembly according to claim 2, wherein the coupler is operable to split the received light beam into two sub-beams one of which is passed directly into the sensor element via a single mode optical fibre, and to receive from

the sensor element the light reflected from the sensor element.

4. An assembly according to claim 3, wherein the means for receiving and processing the reflected light includes a photodetector for receiving the reflected light from the coupler, two lockin detectors operable to sample the reflected light output from the photodetector, one at a frequency of  $1f$  and the other at a frequency of  $2f$ , and demodulate the samples at these two frequencies, and means for logging the demodulated samples and for establishing the inverse tangent of the ratio of the intensity values  $1f:2f$  to extract an interferometer phase to determine the direction and magnitude of the strain on the sensor element.

5. An assembly according to claim 4, wherein the ends of the sensor element fibre are coated to provide the internal peak reflectivity not exceeding 10% and to give a Fabry Perot optical configuration to the sensor fibre.

6. An assembly according to claim 5, wherein the coated ends are provided by a coating of titanium dioxide.

7. An assembly according to claim 6, wherein the coated ends are separated by a distance in the range of from 5 to 50mm.

8. An assembly according to claim 4, wherein the peak reflectivity not exceeding 10% within the sensor element is provided by a Bragg grating at each end of the sensor element fibre which produce in the sensor element a Fabry Perot etalon.

9. An assembly according to claim 8, including means for generating two ultraviolet laser beams and for shining them at oblique angles of incidence to impinge at the same position within the sensor element fibre to generate a set of interferometric fringes to provide the Bragg gratings.

10. An assembly according to claim 9, wherein the means for generating two ultraviolet laser beams includes a phase grating operable to provide the two obliquely angled beams from a single laser source.

11. An assembly according to claim 10, including means for varying the pitch of the Bragg gratings along the length of the gratings to reduce the Bragg grating peak reflectivity to not more than 10% and to increase the Bragg grating reflectance band width to a range of from 10 to 30 nm.

12. A fibre optic interferometric strain gauge assembly substantially as hereinbefore described and as illustrated in Figure 1 as modified or not by Figure 2, Figure 3 or Figure 4 of the accompanying drawings.



Application No: GB 9618621.8  
Claims searched: 1 to 12

Examiner: Donal Grace  
Date of search: 15 January 1997

**Patents Act 1977**  
**Search Report under Section 17**

**Databases searched:**

UK Patent Office collections, including GB, EP, WO & US patent specifications, in:  
UK CI (Ed.O): G1A (ABF, ACEF)  
Int CI (Ed.6): G01B 9/02, 11/16 G01L 1/24  
Other: Online: WPI

**Documents considered to be relevant:**

Category	Identity of document and relevant passage	Relevant to claims
A	GB 2222247 A (PLESSEY) see figure 3	1
A	EP 0727640 A2 (HEWLETT-PACKARD) see figure 1	1

X	Document indicating lack of novelty or inventive step	A	Document indicating technological background and/or state of the art.
Y	Document indicating lack of inventive step if combined with one or more other documents of same category.	P	Document published on or after the declared priority date but before the filing date of this invention.
&	Member of the same patent family	E	Patent document published on or after, but with priority date earlier than, the filing date of this application.