

(12) **UK Patent Application** (19) **GB** (11) **2 288 020** (13) **A**

(43) Date of A Publication **04.10.1995**

(21) Application No **9500250.7**

(22) Date of Filing **06.01.1995**

(30) Priority Data

(31) **9406378** (32) **30.03.1994** (33) **GB**
9408139 **25.04.1994**

(51) INT CL⁶
G01V 1/52 , E21B 17/07

(52) UK CL (Edition N)
G1G GMB G3A
E1F FAC FAC7

(56) Documents Cited
WO 93/07514 A1

(58) Field of Search
UK CL (Edition N) **G1G GEV GMB**
INT CL⁶ **G01V 1/40**

(71) Applicant(s)
GEC-Marconi Limited

(Incorporated in the United Kingdom)

**The Grove, Warren Lane, STANMORE, Middlesex,
HA7 4LY, United Kingdom**

(72) Inventor(s)
John Michael Beresford
Paul Andrew Crowther

(74) Agent and/or Address for Service
G Cockayne
**GEC Patent Department, Waterhouse Lane,
CHELMSFORD, Essex, CM1 2QX, United Kingdom**

(54) **Borehole acoustic sensor**

(57) An acoustic sensor (4) for use as part of a drill string (1) in a borehole has an acoustic transducer which vibrates the drill bit (3) in contact with the rock at the end of the borehole to generate acoustic signals in the rock. These acoustic signals propagate through the rocks ahead of the drill bit and are reflected and scattered to return to an acoustic sensor contained within the drill string. A compliant device connects the drill bit to the drill collar and acts to keep the resonance frequency of the drill tool and drill bit substantially lower than the passband of the acoustic sensor.

GB 2 288 020 A

1/7

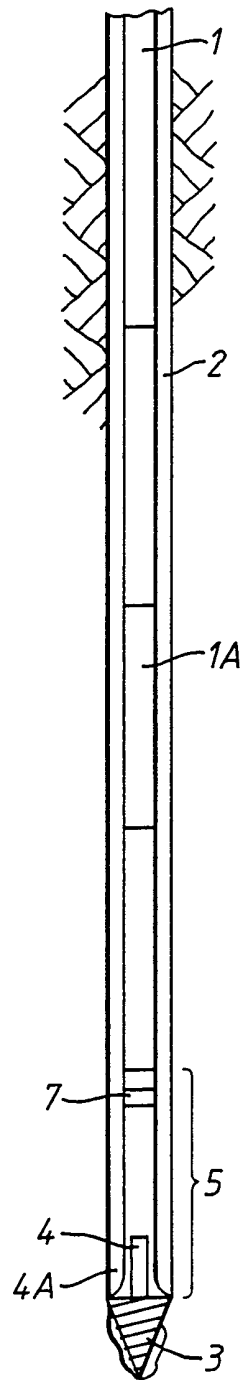

Fig.1

2/7

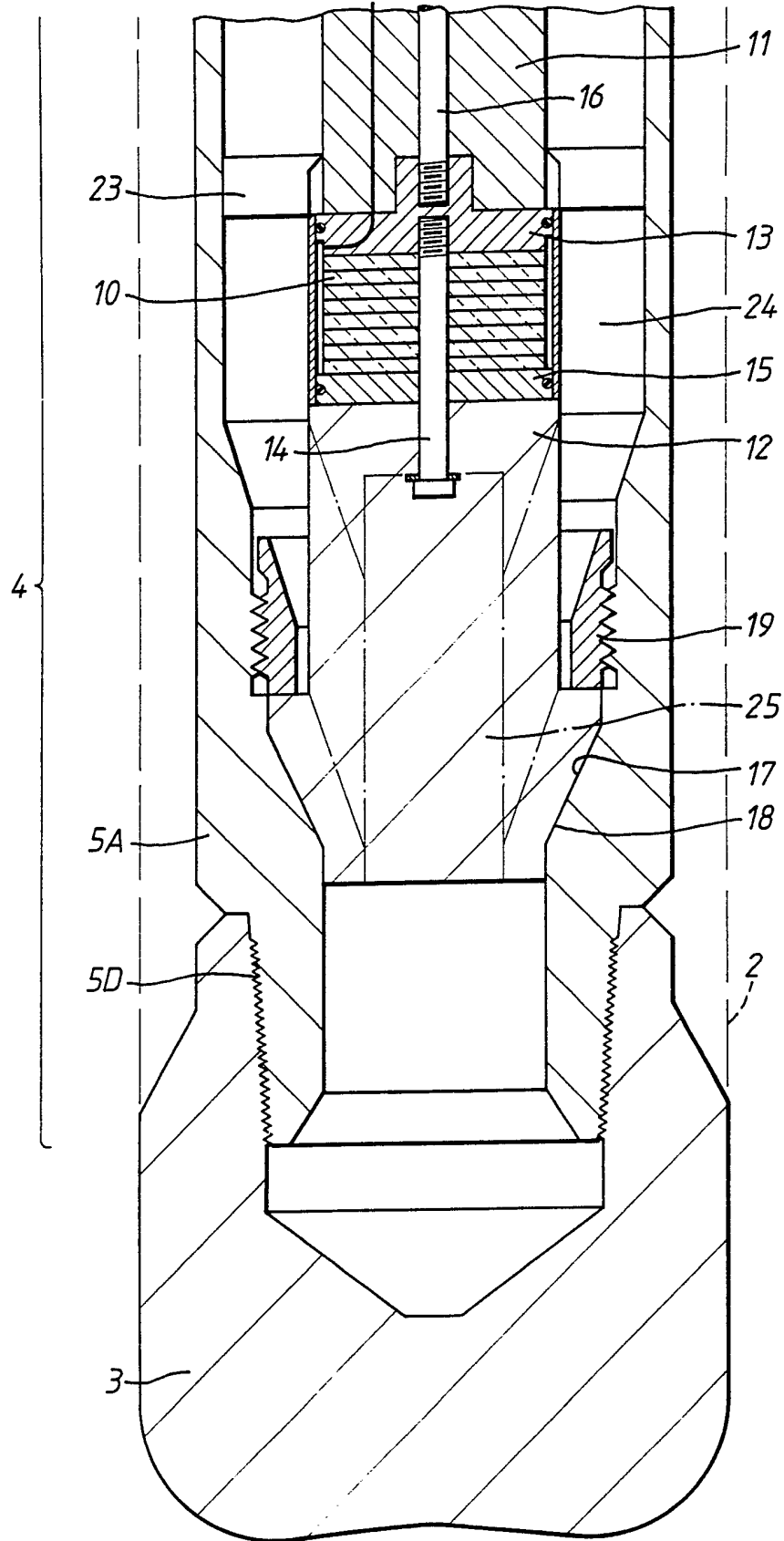

Fig. 2A

3/7

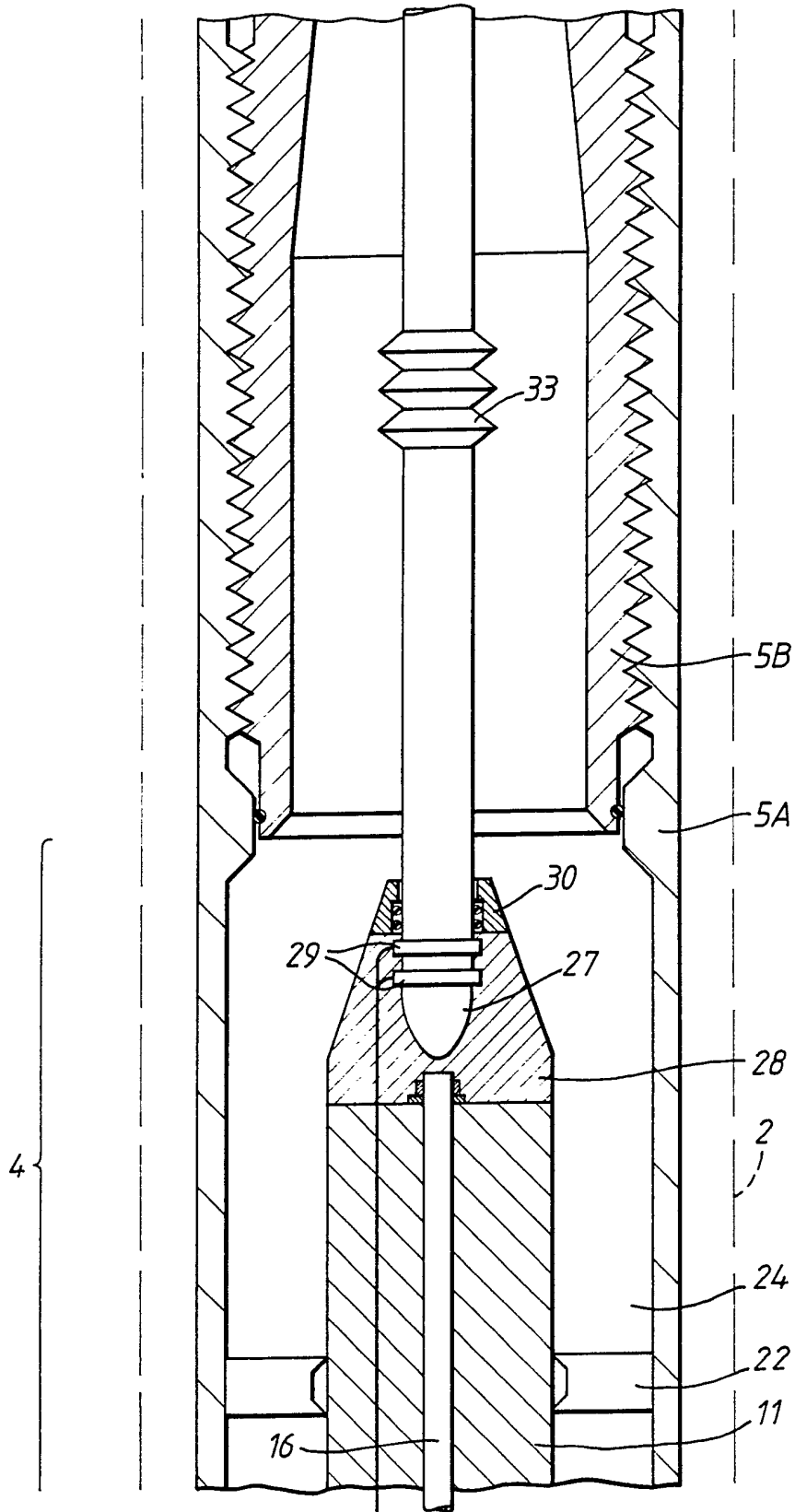

Fig. 2B

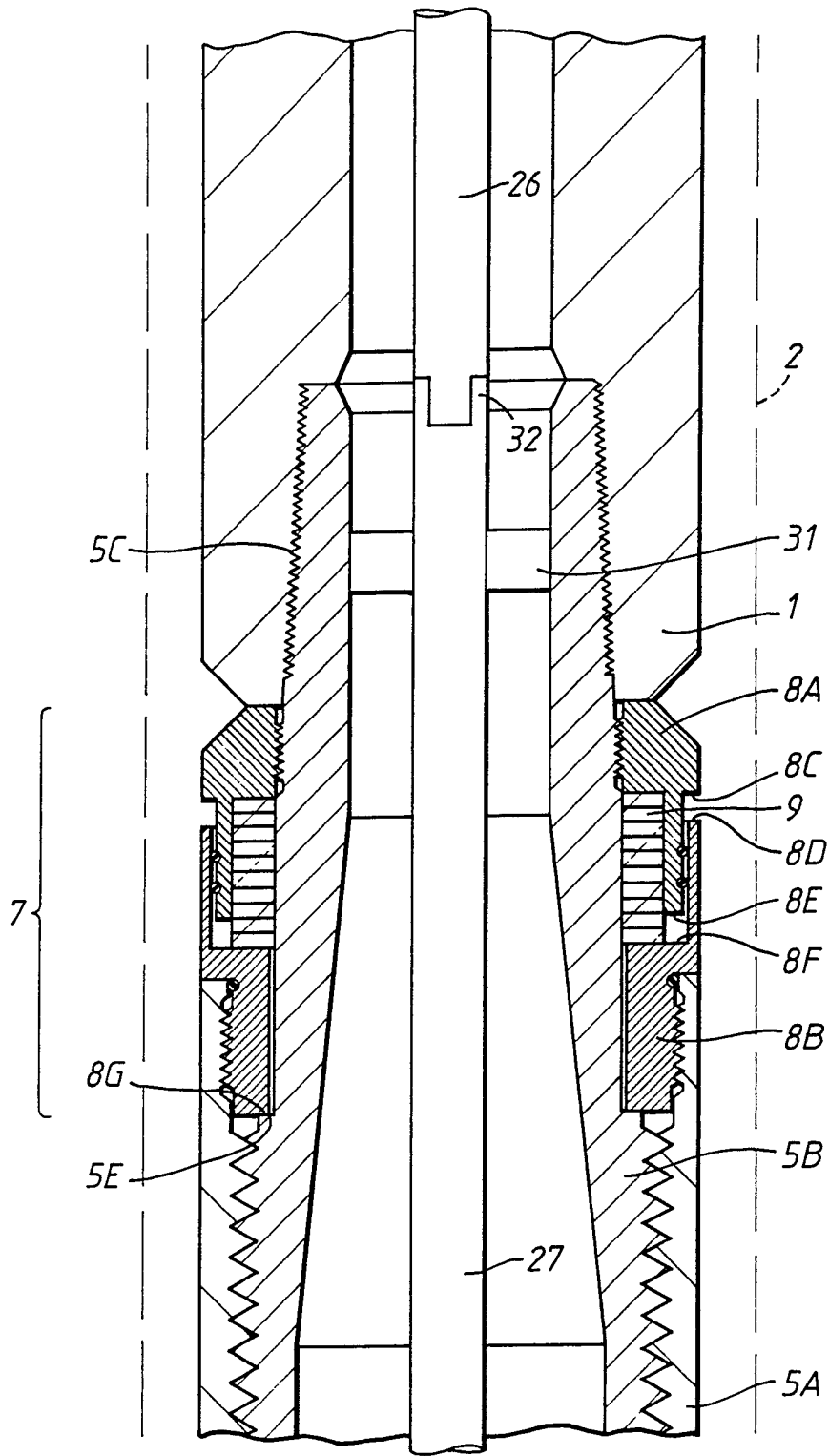

Fig. 2C

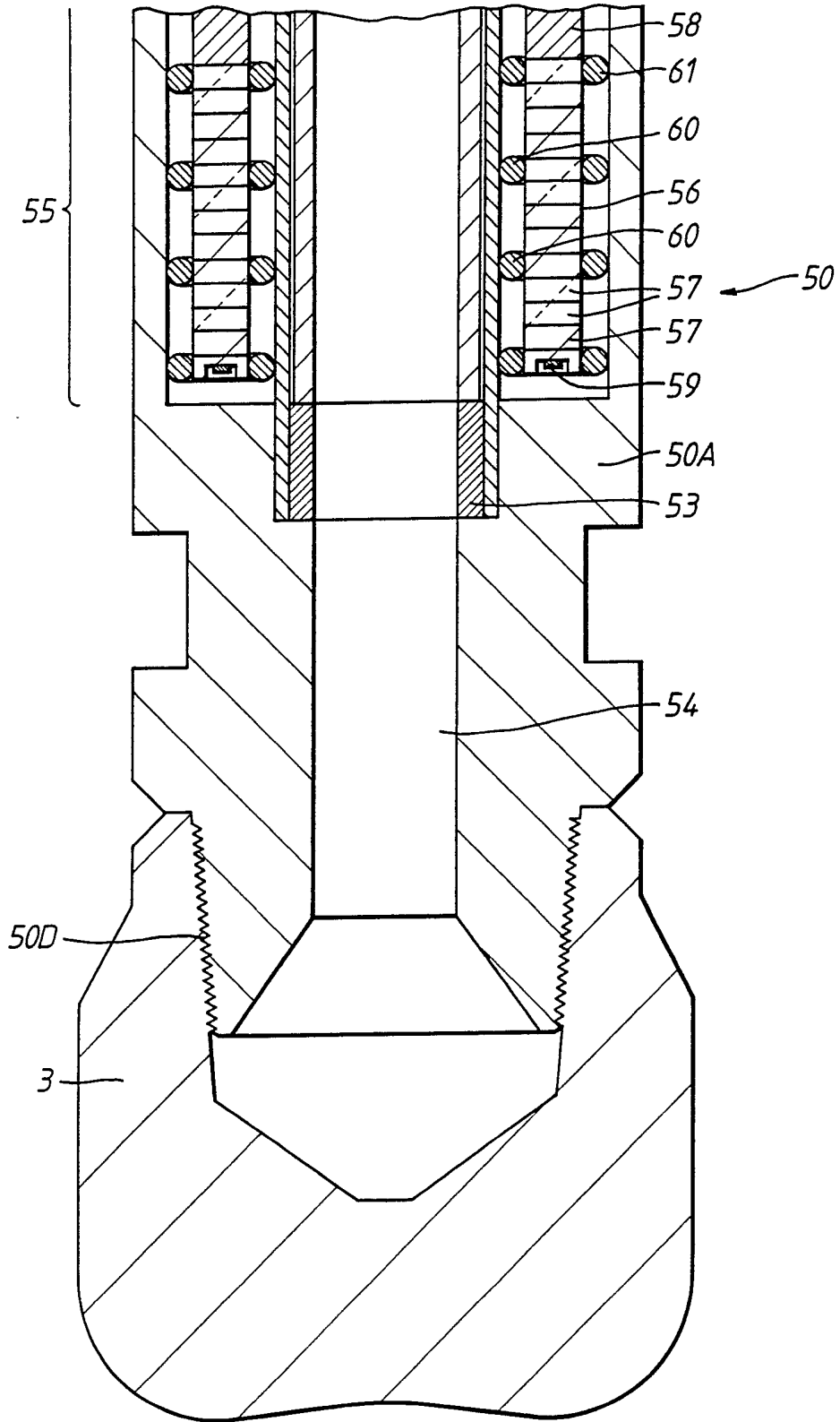

Fig. 3A

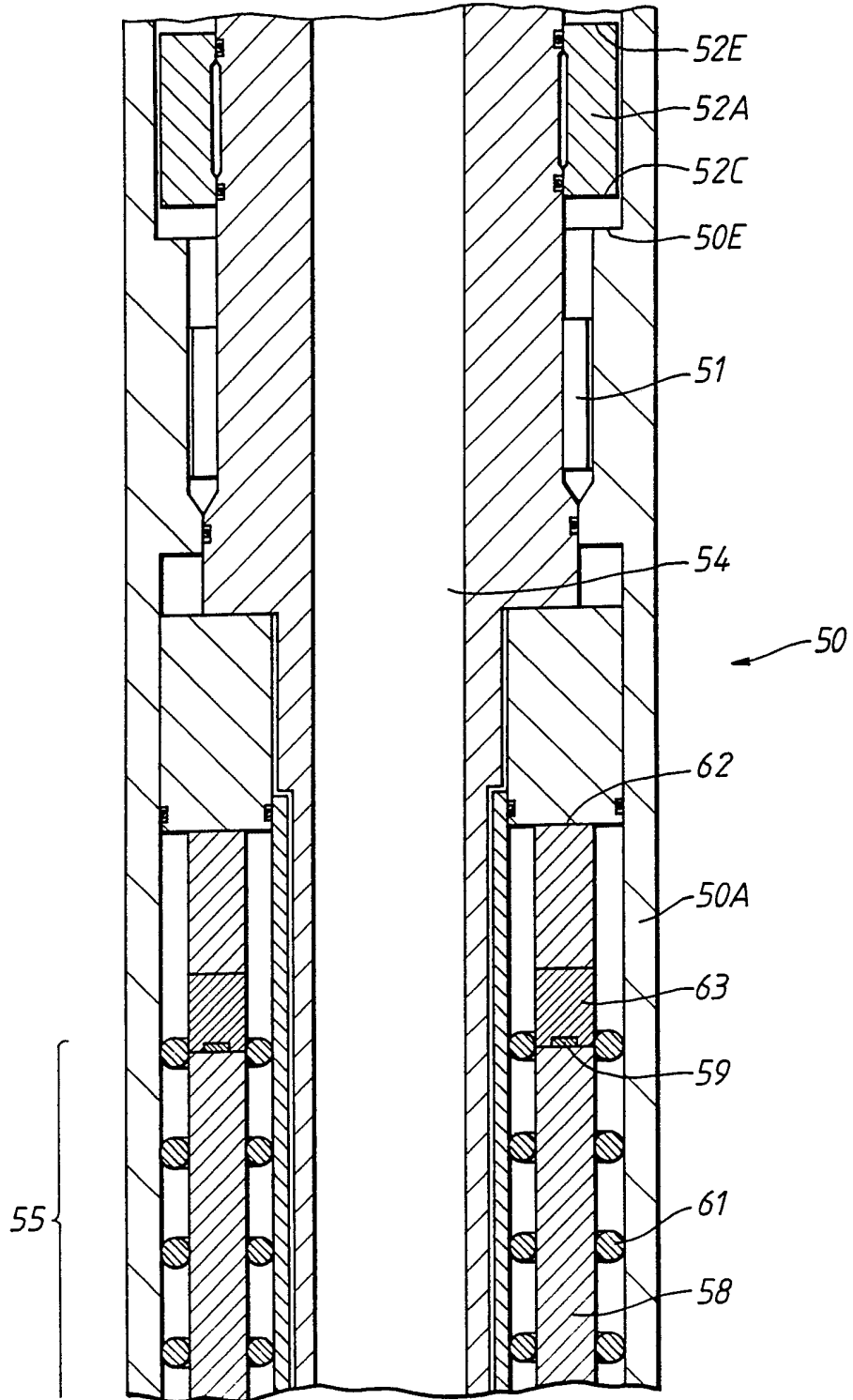

Fig.3B

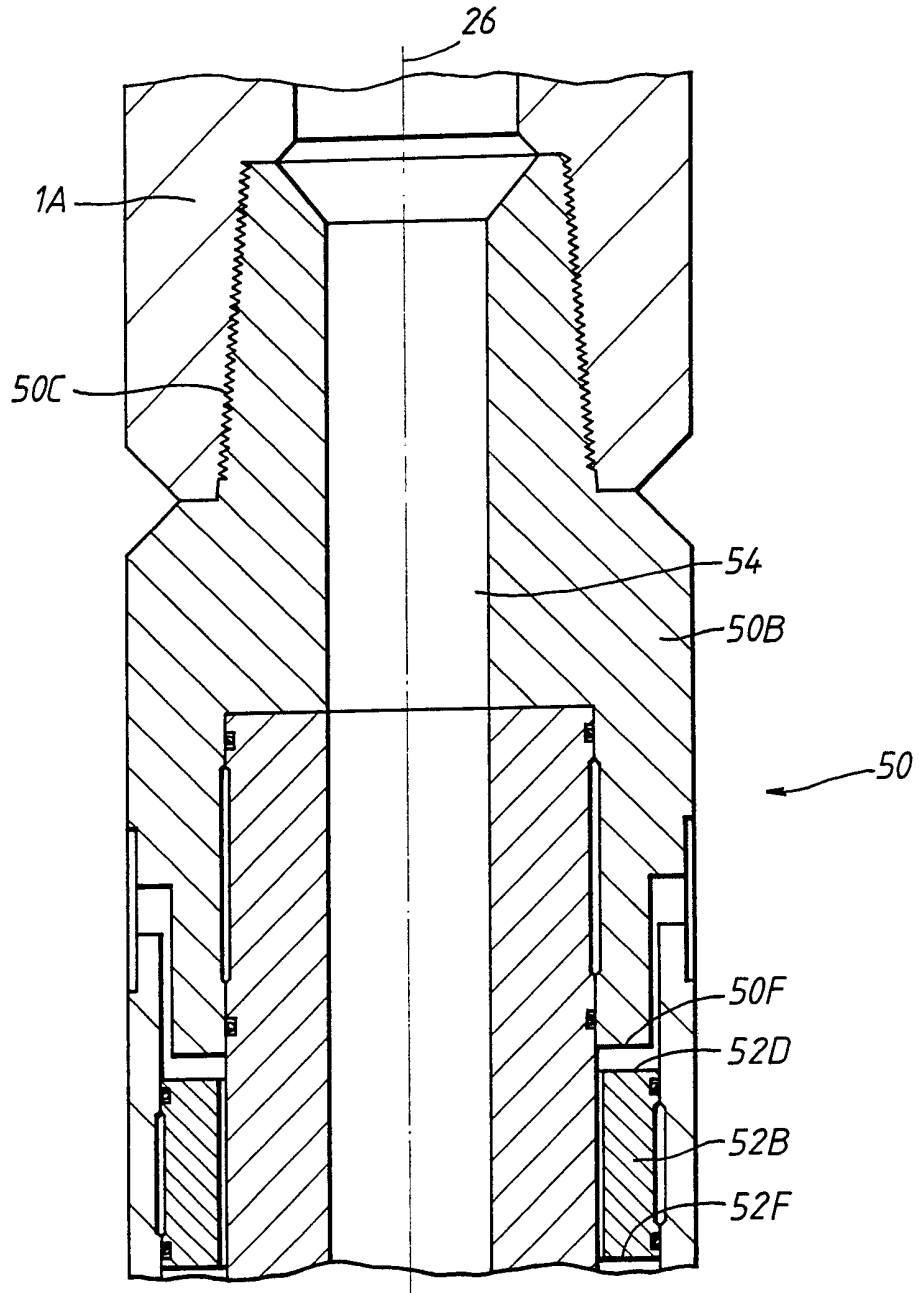

Fig.3C

ACOUSTIC SENSOR

This invention relates to an acoustic sensor for use in drilling.

When drilling, and particularly when drilling for oil, it is desirable to know what strata
5 will be drilled through at any time in order to allow appropriate drilling parameters to be
employed, it is also desirable to have a detailed knowledge of the position of the drill bit relative
to anticipated or known features of the rock strata and to allow geosteering. One particular
concern in oil drilling is the identification of over pressure regions in the strata ahead of the drill
in order to allow the fluid pressure within the borehole to be adjusted to the minimum safe level.
10 Having the minimum safe fluid pressure is desirable because although too low a borehole fluid
pressure, known as underbalancing, produces the danger that if a gas overpressure region is
penetrated the resulting release of gas into the borehole, known as a blowback, can result in loss
of the borehole and drill rig, too high a fluid pressure, known as overbalancing, can damage the
borehole and reduce its oil production capability.

15 Thus in operation it is necessary to balance the risks of under or over balancing the
borehole fluid pressure and to do this accurate data on the presence of overpressure regions is
needed.

20 There have been two general approaches to this problem, the first has been the use of
seismic surveying from the surface to map underground geological features combined with the
use of inertial and magnetic sensors near to the drill bit and dead reckoning to allow the position
of the drill bit relative to these features to be tracked. Unfortunately this approach suffers from
the drawback that the range accuracy and spatial resolution of geological features deep

25 underground obtained by using surface based surveying is very low due to the distances
involved and the fact that the speed of soundwaves through underground strata is dependent on
their makeup. The second approach has been to place acoustic and other surveying instruments
inside the drill string in order to sense the rock strata around the drill during the drilling
operation. This is generally termed "measurement while drilling" or "MWD" although in
30 practice the actual drilling operation may be paused while measurements are being taken. This
approach suffers from the drawback that although the rock strata around the drill can be sensed
this information must then be used to deduce what geological formations are ahead of the drill
bit because it has not been possible to employ sensors capable of looking through the drill bit
into the rock formations the bit is actually drilling towards.

35

As a result there is always considerable uncertainty in such systems regarding the
makeup of the formations directly ahead of the drill bit since it is not always possible to
accurately deduce or extrapolate what these formations will be.

40

It would of course also be possible to extract the entire drill string from the borehole and
send down a wire line tool including an acoustic sensor which would acoustically survey
through the bottom of the borehole to directly survey the rock formations beyond, but the time
and cost penalties associated with extracting the drill string to do this are very high compared
with a MWD survey conducted directly from the drill string, so this is an undesirable procedure.

45

This invention was intended to produce an acoustic sensor within the drill string
overcoming these problems, at least in part.

50 In a first embodiment this invention provides an acoustic sensor comprising a first acoustic transducer attached to a drill string in a borehole and arranged to cause the drill bit to vibrate when in contact with rock at the end of the borehole so as to generate acoustic signals which propagate through the rocks ahead of the drill bit and the drill string having associated with it means for receiving return acoustic signals returned from said rocks.

55 In a second embodiment, this invention provides a compliant device for connecting a drill tool and drill bit including an acoustic sensor to a drill collar and having a compliance such that the resonant frequency produced by the compliance and the mass of the drill tool and drill bit is substantially lower than the passband frequency of the acoustic sensor.

60 Apparatus employing the invention will now be described by way of example only with reference to the accompanying diagrammatic figures in which;

Figure 1 shows a general view of the lower end of a first design of a drill employing the invention,

65

Figure 2a shows a more detailed view of a first part of the view of Figure 1,

Figure 2b shows a more detailed view of a second part of the drill of Figure 1,

70

Figure 2c shows a more detailed view of a third part of the drill of Figure 1,

Figure 3a shows a detailed view of a first part of the lower end of the drill employing a

second embodiment of the invention,

75 Figure 3b shows a detailed view of a second part of the drill of Figure 3a, and

Figure 3c shows a detailed view of a third part of the drill of Figure 3a, identical parts having the same reference numerals throughout.

80 Referring to Figure 1 the lower end of a drill string 1 situated within a borehole 2 and made up of a plurality of screwed together sections is shown.

The drill string is illustrated and described as it would appear when drilling vertically downwards but the drill could of course be operated in other orientations such as in deviated
85 drilling for horizontal wells.

At the lower end of the drill string 1 is an MWD drill collar 1A. The drill collar 1A comprises a plurality of drill pipe sections at the lower end of the drill string 1 as is conventional, at the bottom of the drill collar 1A is a drill bit 3 attached to the drill collar 1A and
90 drill string 1 by a modified drill collar section forming a measurement while drilling, (MWD) tool 5. In order to allow acoustic sensing of the rock strata ahead of the drill bit 3 an acoustic transducer 4 is mounted in close proximity to the drill bit 3 at the base of the MWD tool 5. Since the drill bit 3 is an item which is used until the cutting edge drills and then is sent back to the supplier for refurbishment it is preferred to make the acoustic transducer 4 part of the MWD
95 tool 5 rather than the bit 3, however it would be possible to make the acoustic transducer 4 part of the drill bit 3 to provide the most direct acoustic path into the rock in order to provide the

optimum coupling.

100 During drilling the acoustic transducer 4 does not operate and the drill bit 3 is rotated while being urged against the end of the borehole 2 with a weight on bit (WOB) provided by the weight of the drill string 1, primarily by the drill collar 1A. This WOB is controlled by the driller as normal. Because of the very high acoustic noise levels generated by the drilling operation in the rock strata and along the drill string 1 it is preferred not to attempt to use the acoustic transducer 4 while actual drilling is going on. When acoustic sensing of the rock strata
105 ahead of the drill bit 3 is desired drilling is paused and the part of the MWD tool 5 which contains the acoustic transducer 4 and drill bit 3 is separated acoustically from the remainder of the drill collar 1A and drill string 1 by a compliant section 7 of the MWD tool 5 while the drill bit 3 is loaded against the end of the borehole 2 with a specified WOB. This specified WOB will generally be less than the maximum allowable WOB used for actual drilling.

110

The acoustic transducer 4 then vibrates generating soundwaves through the rock because of the direct acoustic coupling between the acoustic transducer 4 through the drill bit 3 to the rock. These acoustic waves travel through the rock strata below the bottom of the borehole, are reflected and scattered and then received by the acoustic transducer 4. The characteristics of the
115 rock strata can then be deduced from the type, amplitude and timing of these received signals.

Alternatively or in addition a dedicated receiving section either at or near the drill bit or further up the drill collar 1A and including an acoustic transducer or a detector array formed by a plurality of acoustic transducers, and/or vibration sensitive devices clamped to the well wall,
120 as known in the current art for wire logging tools, could be employed. It is preferred to use a

piezo-ceramic stack as acoustic transducer for both transmitting and receiving.

The compliant section 7 of the MWD tool 5 which allows the WOB to be varied as required for acoustic sensing acts as an acoustic isolator between the acoustic transducer 4 and the drill collar 1A and drill string 1 reducing the amount of unwanted acoustic energy transmitted along the drill string 1. In order to do this the compliance of the compliant section must be such that the resonant frequency caused by the mass suspended from the compliant section and the compliance of the compliant section is substantially lower than the passband frequency of the acoustic transducer 4 in contact with expected rock types.

Referring to Figures 2A to 2C the measurement while drilling (MWD) tool 5 is shown in detail. The Figures 2A to 2C are cross sections through the drill arranged from the bottom of the drill upwards.

The MWD tool 5 is attached by a first conventional conical screw threaded joint 5C at its upper end to the bottom of the drill collar 1A and is attached by a second conventional screw threaded joint 5D at its lower end to the drill bit 3. The MWD tool 5 comprises an outer hollow cylindrical member 5A mounting the drill bit 3 at its lower end by the conventional conical threaded joint 5D and substantially surrounding an inner hollow cylindrical member 5B which is attached to the lower end of the drill collar 1A by the conventional conical screw threaded joint 5C.

The outer and inner hollow cylindrical members 5A and 5B have co-operating longitudinal splines on their inner and outer surfaces respectively allowing them to slide axially

145 relative to one another but still allowing large rotational loads to be transmitted along the drill collar 1 through the two members 5A and 5B to the drill bit 3 during drilling.

In the example illustrated the inner hollow cylindrical member 5B is approximately one half of the length of the outer hollow cylindrical member 5A, these relative lengths could of course be varied depending on the material used to construct the two members and the loads being placed upon them in operation. Further, to allow for a lower internal diameter at the compliance, if required, and for ease of assembly the inner hollow cylindrical member 5B could be formed as two parts.

155 Relative axial sliding movement of the inner and outer cylindrical members 5A and 5B is limited by a pair of stop rings 8A and 8B. A compression stop ring 8A is attached to the inner member 5B to set the minimum length of the overall MWD tool 5 assembly and an extension stop ring 8B attached to the outer member 5A to limit the maximum length of the overall MWD drill tool 5 assembly. An annular compliant member 9 is mounted between the two stop rings 8A and 8B.

160 During drilling the weight on bit (WOB) bears on the MWD tool 5, compressing the compliant member 9, and at the upper limits of WOB this compression is such that the compression and extension stop rings 8A and 8B come into contact at co-operating snubbing surfaces 8C and 8D and 8E and 8F. Once the snubbing surfaces 8C and 8E of the compression stop ring 8A are in contact with their respective co-operating snubbing surfaces 8D and 8F of the extension stop ring 8B the maximum drilling load is transmitted between them between the inner and outer members 5A and 5B to the drill bit 3. This snubbing action may either be hard

170 or soft with another suitable compliant interface (not shown) being used if necessary. It would
of course be possible to have only one pair of co-operating snubbing surfaces on the stop rings
8A and 8B.

175 When it is desired to take acoustic measurements the WOB is adjusted by the driller in
the usual manner so that the compression and extension stop rings 8A and 8B separate. The
WOB of the drill bit 3 is then set by a force generated by the compliant member 9 onto the
various elements attached to the drill bit 3 plus the weight of those elements. In order to allow
the drill bit 3 and MWD tool 5 to be extracted from the borehole 2, the extension stop ring 8B
also has a third snubbing surface 8G which contacts a co-operating snubbing surface 5E on the
inner cylindrical member 5B to limit extension of the MWD tool 5.

180

When extracting the MWD tool 5 and drill bit 3 tensional loads are passed through the
snubbing surfaces 8G and 5E to allow the drill string 1 to pull out the MWD tool 5 and attached
drill bit 3.

185

The acoustic transducer 4 is rigidly attached to the outer member 5A of the MWD tool
5. The acoustic transducer 4 comprises a stack of piezoelectric ceramic, commonly termed
piezo-ceramic, disks 10, which form the electro-acoustically active part of the transducer 4, a
tail mass 11, a stack base 12 and a central disc 13. The central disc 13, stack base 12 and stack
10 are all secured rigidly together by a first bolt 14 passing along their axis and into a threaded
190 hole in the central disc 13, which is tightened to pre-compress the ceramic stack 10 between the
disc 13 and a stack end cap 15 placed between the stack 10 and the base 12. The tension of the
first bolt 14 is set to ensure that under all operating conditions the ceramic stack 10 is in

compression. The tail mass 11 is secured rigidly to the central disc 13 by a second bolt 16 passing along the axis of the tail mass 11 and into a threaded hole in the central disc 13. The stack base 12 has a conical bearing surface 17 on its outer surface and the acoustic transducer 4 is rigidly connected to the outer member 5A by this bearing surface 17 being urged against a corresponding conical bearing surface 18 on the inner surface of the outer member 5A, the two mating bearing surfaces 17 and 18 being urged together by a threaded base ring 19 which cooperates with a threaded inner portion of the outer member 5A. The ceramic stack 10 is surrounded by a cylindrical jacket 20 filled with a non-conductive fluid such as fluorinert. The jacket 20 and tail mass 11 are kept centred within the outer body 5A by a set of spiders 22 and 23 extending between the jacket 20 and tail mass 11 and the inner surface of the outer member 5A. The spiders 22 and 23 are soft in the axial direction to avoid being an acoustic short, stiff in the radial direction to stop shock loads causing the tail mass to break the ceramic assembly and have to transmit loads circumferentially to prevent angular accelerations from drill string windup causing the tail mass 11 to rotate relative to the stack base 12 because this would either loosen or overtighten the bolt 14. The spiders must also allow free passage to the drilling fluid.

During drilling large quantities of drilling fluid (commonly known as drilling mud) are passed down the inside of the drill string 1 under high pressure into the drill bit 3, in order to allow this the outer jacket 20 and tail mass 11 of the acoustic transducer 4 are arranged centrally within the hollow outer member 5A of the drill tool 5 leaving an annular mud passage 24 between them. In order to allow the mud to pass down this mud passage 24 to the drill bit 3 the spiders 22 and 23 are each formed by a plurality of radial vanes with mud gaps between them and the stack base 12 has mud passages 25 through it connecting the annular mud passage 24 to the drill bit 3. The spiders 22 and 23 are also formed by a plurality of vanes to constrain any

relative rotational movement of the outer member 5A and the tail mass 11 and jacket 20 by the vanes transmitting loads circumferentially. Such rotational movement could otherwise occur during drilling due to the high torsional loads on the MWD tool 5 and as a consequence of drill string windup.

During acoustic sensing voltages are applied across the ceramic stack 10, causing it to impact a vibrating force on the drill bit 3 and attached masses and the tail mass 11. The system is arranged with a double mechanical resonance such that the drill bit 3 and attached masses resonates with the compliance of the rock while the tail mass 11 resonates with the compliance of the ceramic stack 10. The piezoelectric transducer is also arranged to have an electrical resonance to allow a wide range of operating frequencies and to minimise droop and ripple in the acoustic passband.

Clearly in order to do this a supply of electrical power is required and a connection to a power supply (not shown) housed in the drill collar 1A is provided along the axis of the drill collar 1A by an electrical cable carrier 26. The electrical cable carrier 26 is formed by a plurality of sections, each within one of the drill pipe sections forming the drill collar 1 and linked by threaded joints. Of course these joints would not be necessary if the power supply were housed in the drill collar section adjacent the MWD tool 5. A probe 27 is mounted within the MWD tool 5 along its axis and the lower end of the probe 27 fits into a socket 28 mounted on the upper end of the tail mass 11 of the acoustic transducer 4.

The power supply is a battery pack, but other systems such as a mud turbine could be used.

The socket 28 contains a pair of slip ring connectors 29 which co-operate with electrical contact pads (not shown) on the outer surface of the probe 27 and the probe 27 is locked inside the socket 28 by a releasable locking mechanism 30. The locking mechanism 30 and rings 29 allow relative rotational movement of the probe 27 and socket 28 during the assembly of the MWD tool 5 and due to torsional loads on the MWD tool 5. The probe 27 is attached to the inner member 5B by a vaned spider 31 and is linked to the electrical cable carrier 26 within the drill collar 1A by a threaded joint 32. A compliant telescopic section 33 of the probe 27 allows the length of the probe 27 to be varied over the same range as the MWD tool 5 and acts as an acoustic break to prevent the probe 27 forming an acoustic path from the transducer 4 to the rest of the drill string 1, whilst maintaining electrical continuity. The compliant telescopic section could of course be part of the socket 28 and vary its length instead of or as well as that of the probe 27.

The acoustic transducer 4 acts as an acoustic receiver as well as a transmitter and the data picked up by the acoustic transducer 4 acting as a receiver is transmitted to a mud pulser (not shown) mounted within the drill collar 1A by the electrical cable carrier 26 and then transmitted to the surface. The data is carried to the electrical cable carrier 26 by the probe 27 and further slip rings (not shown). The data is pre-processed downhole by a processor co-located with the mud pulser to reduce the data rate to a level commensurate with the few bits per second bandwidth capability of the mud pulser data link. Other means of sending the data to the surface could be used such as acoustic signals up the walls of the drill string or extending the electrical cable carrier 26 to the surface.

In addition to the acoustic transducer 4 single axis or triaxial vibration sensors may also

265 be mounted at position 4A in Figure 1, in this case enough slip rings 29 and contact pads would
have to be provided to allow this extra data transmission to the electronic processing contained
in MWD drill collar 1A as well as power transmission from the power supply contained in the
MWD drill collar 1A. A single axis vibration sensor could be used to receive compression wave
signals reflected from rock strata ahead of the drill bit 3. A triaxis vibration sensor could convert
270 reflected acoustic signals into electrical signals relating to three orthogonal accelerations,
providing information useful in separating received signals by direction of arrival and
discriminating between compression and shear waves.

In order to prevent the high pressure drilling mud escaping from the interior of the drill
275 25 annular seals are provided between all of the parts arranged for relative movement and, as is
well known in the art, these seals can be pressure and volume compensated and protected from
the abrasive effects of the drilling mud.

The telescopic compliant section 33 of the probe 27 is only shown as an exemplary
280 bellows type telescoping section, but it could of course be realised in other ways such as
relatively sliding telescopic tubes.

The socket 28 receiving the probe 27 is hollow in the example and could be filled with
non-conductive fluid if desired to increase its elastic stability and its resistance to penetration
285 by the high pressure mud flow around it.

The locking mechanism 30 securing the probe 27 in the socket 28 need not be releasable
but it is convenient for it to be releasable in order to allow easy dismantling and servicing of the

equipment.

290

If desired relative movement of the probe 27 and socket 28 could be absorbed by a compliance situated within the socket 28 instead of having a compliant telescopic section in the probe 27.

295

Instead of being mounted on the MWD tool 5 as shown the probe 27 could be an extension of the electrical cable carrier 26, the spider 31 and threaded joint 32 would then not be necessary. In this case the slip ring connectors 29 would be necessary to allow relative rotational movement of the probe 27 and socket 28 when the MWD tool 5 was attached to the drill collar 1A.

300

Referring to Figures 3a to 3c an alternative arrangement of measuring while drilling (MWD) tool 50 is shown in detail. The Figures 3a to 3c are cross-sections through the drill arranged from the bottom of the drill upwards.

305

The MWD tool 50 is attached in the same way as in the previous example by a first conventional conical screw threaded joint 50C at its upper end to the bottom of the drill collar 1A and is attached by a second conventional screw threaded joint 50D at its lower end to the drill bit 3. The MWD tool 50 comprises a first hollow member 50A mounting the drill bit *3 at*

310

~~throughout~~ its lower end by the conventional conical threaded joint 50D, and a second hollow substantially cylindrical member 50B which is attached to the lower end of the drill collar 1A by the conventional conical screw threaded joint 50C. The first hollow member 50A surrounds the second hollow member 50B for a portion of its length.

The first and second hollow cylindrical members 50A and 50B have co-operating longitudinal splines 51 on their inner and outer surfaces respectively allowing them to slide axially relative to one another but still allowing large rotational loads to be transmitted along the drill collar 1 through the two members 50A and 50B to the drill bit during drilling.

Relatively axial sliding movement of the first and second cylindrical members 50A and 50B is limited by a pair of stop rings 52A and 52B attached to the first and second cylindrical members 50A and 50B respectively. The stop rings 52A and 52B set the maximum and minimum lengths of the overall MWD tool 50 assembly. An annular compliant member 53 is mounted between the first and second cylindrical members 50A and 50B, unlike the previous example the compliant member is not located between the stop rings.

During drilling the weight on bit (WOB) bears on the MWD tool 50, compressing the compliant member 53, and at high levels of WOB this compression is such that snubbing surfaces 52C and 52D of the first and second stop rings 52A and 52B respectively come into contact with co-operating snubbing surfaces 50E and 50F of the first and second cylindrical members 50A and 50B respectively. Once the snubbing surfaces 50E and 50F are in contact with the snubbing surfaces 52C and 52D the maximum drilling load is transmitted between the first and second members 50A and 50B to the drill bit 3. This snubbing action may be either hard or soft with another suitable compliant interface (not shown) being used if necessary. It would of course be possible to have only one of the pair of stop rings 52A and 52B contacting the appropriate one of the first and second cylindrical members 50A and 50B to carry out this snubbing action.

When it is desired to take acoustic measurements the WOB is adjusted by the drill in the usual manner so that the snubbing surfaces 50E, 50F and 52C, 52D of the first and second cylindrical members 50A and 50B and the first and second stop rings 52A and 52B respectively
340 separate. The WOB of the drill bit 3 is then set by a force generated by the compliant member 53 onto the various elements attached to the drill bit 3 plus the weight of those elements.

In order to allow the drill bit 3 and the MWD tool 50 to be extracted from the bore hole the first and second stop rings 52A and 52B have co-operating snubbing surfaces 52E and 52F
345 respectively which come into contact to limit the extension of the MWD tool 50. When extracting MWD tool 50 and drill bit 3 tensional loads are passed through the snubbing surfaces 52E and 52F to allow the drill string 1 to pull out the MWD tool 50 and attached drill bit 3.

During drilling large quantities of drilling fluid are passed down the inside of the drill
350 string 1 under high pressure into the drill bit 3 and in order to allow this a continuous cylindrical fluid passage 54 passes down the centre of the MWD tool 50 and the acoustic transducer 55 is constructed as a hollow cylinder surrounding this fluid passage 54.

The acoustic transducer 55 comprises a stack 56 of annular piezoceramic elements 57
355 which form the electro-acoustically active parts of the transducer 55 and an annular tail mass 58. The piezoceramic elements 57 and tail mass 58 are secured rigidly together by a plurality of bolts 59 which are tightened to pre-compress the stack 56 of ceramic elements 57. The tension in the bolts 59 is set to ensure that under normal operating conditions the ceramic stack 56 is in compression.

The acoustic transducer 55 is located between the first and second cylindrical members 50A and 50B and is prevented from moving radially relative to the first and second cylindrical members 50A and 50B by a plurality of inner elastomeric spacer rings 60 between the transducer 55 and the second cylindrical member 50B and a plurality of outer elastomeric spacer rings 61
365 between the acoustic transducer 55 and the first cylindrical member 50A.

The transducer 55 can be moved axially by a party of hydraulic rams 62 secured to the first cylindrical member 50A which are attached to the tail mass 58 of the transducer 55 through an annular compliant member 63. The space surrounding the acoustic transducer 55 between
370 the first and second cylindrical members 50A and 50B is filled with an inert fluid to protect the electro-acoustically active parts of the transducer 55.

During drilling and during transport and handling of the MWD tool 50 the hydraulic rams 62 are retracted to move the acoustic transducer 55 out of contact from the first cylindrical
375 member 50A. The acoustic transducer 55 is then supported by the elastomeric rings 60 and 61 and the compliant member 63 and as a result it is isolated from vibration and shock, preventing damage to the transducer 55 and particularly to piezoceramic elements 57.

When MWD measurements are to be carried out the hydraulic rams 62 push the
380 transducer 55 so that its lower end 55A is brought into contact with the first cylindrical member 50A to provide good acoustic coupling between the drill bit 3 and acoustic transducer 55 by way of the first cylindrical member 50A. The acoustic transducer 55 remains acoustically isolated from the other parts of the drill string 1 by the elastomeric rings 60 and 61, and the compliant members 53 and 63.

385 As in the previous example electrical power and data links and annular seals are required,
but it is not felt necessary to discuss these in detail since it would be clear from the preceding
example how such links and seals can be achieved.

390 In both examples shown the MWD tool bears a male threaded joint for connection to a
drill bit bearing a female threaded joint, it would of course be possible for the male and female
parts of this joint to be reversed if desirable.

Other transducer geometries or arrangements besides those described could be used but
those described are felt to be particularly advantageous.

395

Obviously other methods of securing together the elements of the acoustic transducer
or indeed the entire assembly could be used.

400 An estimate of the useful range of movement from the compliant section of the drill tool
is 10 millimetres.

The compliant member can be a single annular element or a plurality of separate
elements arranged within an annular region.

405

If preferred, conventional shock absorbing units could be placed between MWD tool and
drill collar 1 to improve the drilling performance of the drill as is known. Such shock absorbers
employ resilient members which transmit the full WOB for drilling and are designed for
reducing shock to the bit and MWD tool and so could not be used in place of the compliant parts

of the present invention to allow WOB to be varied and provide acoustic de-coupling they also
410 cannot be so used because they add too much mass to the bit to resonate at the desired frequency
with the rock. Such conventional shock absorbing elements could however be combined with
the resilient parts of the present invention in a single structure performing both functions.

In the example shown the acoustic transducer is mounted at the lower end of the MWD
415 tool and is linked by a solid element to the drill bit 3, but it would also be possible to mount the
acoustic transducer 4 at a higher position, in the MWD tool or even within a higher section in
the drill collar 1A, such as the one containing the power supply, electronics and processing
packages and mud pulsing device or the acoustic receiver array, if one was used. In this case
420 the acoustic transducer could be acoustically linked to the drill bit 3 by the drill mud or could
impart its acoustic energy through the drill mud into the rock rather than through the drill bit into
the rock directly.

The use of rotationally symmetrical elements is convenient because this is traditional in
drilling technology and facilitates the use of screw joints etc, but non rotationally symmetrical
425 structures could be used if desired.

The acoustic transducer illustrated has a large number of piezo-ceramic discs, the number
of such discs employed can be varied depending on the performance required and materials used.
Generally the number of discs required will also depend on their diameter, which will often be
430 limited by the collar diameter.

Where an array of acoustic transducers are used they can advantageously be arranged in

a vertical array so that they can easily discriminate between compressional wave signals arising substantially from ahead of the drill bit, down travelling waves in the drill string and sideways received compressional and shear waves from regions not ahead of the drill bit or scattered from
435 heterogeneities in the rock.

CLAIMS

- 440 1. An acoustic sensor comprising a first acoustic transducer attached to a drill string in a borehole and arranged to cause the drill bit to vibrate when in contact with rock at the end of the borehole so as to generate acoustic signals which propagate through the rocks ahead of the drill bit and the drill string having associated with it means for receiving return acoustic signals returned from said rocks.
- 445 2. A sensor as claimed in claim 1 in which the acoustic signals propagate through the rocks to the side and ahead of the drill bit.
- 450 3. A sensor as claimed in claim 1 or claim 2 in which the first acoustic transducer is the means for receiving the return acoustic signals.
4. A sensor as claimed in claim 1 or claim 2 in which a second acoustic transducer is the means for receiving the return acoustic signals.
- 455 5. A sensor as claimed in any preceding claim in which an array of acoustic transducers are attached to the drill string to receive the return acoustic signals.
- 460 6. A sensor as claimed in any preceding claim in which the first acoustic transducer is a piezo-ceramic transducer with one face connected to the drill bit and an opposite face connected to a tail mass.

7. A sensor as claimed in any preceding claim in which the first acoustic transducer is releasably connected to the drill bit.
8. A sensor as claimed in claim 6 in which the first acoustic transducer has two mechanical resonances, a first with the drill bit and a second with the tail mass.
465
9. A sensor as claimed in claim 8 in which the two mechanical resonances have different frequencies.
10. A sensor as claimed in any one of claims 6 to 9 in which the first transducer is electrically tuned to have an electrical resonance.
470
11. A sensor as claimed in claim 5 in which the array comprises a plurality of acoustic transducers arranged such that they can be used to discriminate between compression waves arriving substantially from ahead of the drill bit, down travelling waves in the drill string and sideways received compressional and shear waves.
475
12. A sensor as claimed in claim 11 in which the array comprises a plurality of acoustic transducers arranged along the length of the drill string.
480
13. A sensor as claimed in any one of claims 5, 11 or 12 in which processing means are provided to allow the sensitivity of the array to be steered to allow the array to look off the axis of the drill string.

- 485 14. A sensor as claimed in any one of claims 5 and 11 to 13 in which the acoustic transducers are accelerometers.
15. A sensor as claimed in any one of claims 5 and 11 to 13 in which the acoustic transducers are geo-phones in contact with the borehole wall.
- 490 16. A sensor as claimed in any of claims 5 and 11 to 13 in which the acoustic transducers are hydrophones.
17. A sensor as claimed in claim 16 in which the hydrophones are mounted on the outer
495 circumference of a drill collar.
18. A sensor as claimed in any preceding claim in which the first acoustic transducer and drill bit can be separated to allow drill bit replacement.
- 500 19. A sensor as claimed in any preceding claim in which an additional single axis vibration sensor is provided for reception of compression wave signals.
20. A sensor as claimed in any one of claims 1 to 18 in which a three axis vibration sensor is provided.
- 505 21. A compliant device for connecting a drill tool and drill bit including an acoustic sensor to a drill collar and having a compliance such that the resonant frequency produced by the compliance and the mass of the drill tool and drill bit is substantially lower than the

passband frequency of the acoustic sensor.

510

22. A sensor as claimed in any of claims 1 to 20 in which a compliant electrical connector links the acoustic transducer with electronics further up the drill collar.

Relevant Technical Fields

- (i) UK Cl (Ed.N) G1G-GEV, GMB
- (ii) Int Cl (Ed.6) G01V-1/40

Search Examiner
 S J DAVIES

Date of completion of Search
 22 FEBRUARY 1995

Databases (see below)

- (i) UK Patent Office collections of GB, EP, WO and US patent specifications.

Documents considered relevant following a search in respect of Claims :-
 1-20, 22

(ii)

Categories of documents

- | | |
|---|---|
| X: Document indicating lack of novelty or of inventive step. | P: Document published on or after the declared priority date but before the filing date of the present application. |
| Y: Document indicating lack of inventive step if combined with one or more other documents of the same category. | E: Patent document published on or after, but with priority date earlier than, the filing date of the present application. |
| A: Document indicating technological background and/or state of the art. | &: Member of the same patent family; corresponding document. |

Category	Identity of document and relevant passages	Relevant to claim(s)
A	WO 93/07514 A1 (ATLANTIC RICHFIELD) see eg page 20, lines 1-17; Figure 2b	

Databases: The UK Patent Office database comprises classified collections of GB, EP, WO and US patent specifications as outlined periodically in the Official Journal (Patents). The on-line databases considered for search are also listed periodically in the Official Journal (Patents).