



(11) **EP 1 584 571 B1**

(12) **EUROPEAN PATENT SPECIFICATION**

(45) Date of publication and mention of the grant of the patent:
07.07.2010 Bulletin 2010/27

(21) Application number: **03812302.2**

(22) Date of filing: **25.11.2003**

(51) Int Cl.:
B65D 41/62 (2006.01)

(86) International application number:
PCT/JP2003/015047

(87) International publication number:
WO 2004/050497 (17.06.2004 Gazette 2004/25)

(54) **CAP FOR CANNED DRINK**

VERSCHLUSS FÜR DOSENGETRÄNK
COUVERCLE POUR BOITES-BOISSON

(84) Designated Contracting States:
AT BE BG CH CY CZ DE DK EE ES FI FR GB GR HU IE IT LI LU MC NL PT RO SE SI SK TR

(30) Priority: **29.11.2002 JP 2002348404**

(43) Date of publication of application:
12.10.2005 Bulletin 2005/41

(73) Proprietors:
• **Onoda, Shigeyoshi**
Toyohashi City,
Aichi 441-1112 (JP)
• **Matsuura, Harumi**
Toyohashi City,
Aichi 441-1111 (JP)

(72) Inventor: **ONODA, Yoshio**
Toyohashi City, Aichi 441-1112 (JP)

(74) Representative: **Higgs, Jonathan et al**
Urquhart-Dykes & Lord LLP
30 Welbeck Street
London W1G 8ER (GB)

(56) References cited:
WO-A-89/11421 DE-U1- 7 801 717
JP-A- 9 207 956 JP-A- 2000 109 107
JP-U- 5 046 755 US-A- 4 815 628
US-A- 5 139 163

EP 1 584 571 B1

Note: Within nine months of the publication of the mention of the grant of the European patent in the European Patent Bulletin, any person may give notice to the European Patent Office of opposition to that patent, in accordance with the Implementing Regulations. Notice of opposition shall not be deemed to have been filed until the opposition fee has been paid. (Art. 99(1) European Patent Convention).

Description**BACKGROUND OF THE INVENTION****FIELD OF THE INVENTION**

[0001] The present invention relates to a cap for canned drinks that covers the top face of a container for canned drinks, where an opening for drinking is disposed, to preserve hygiene before opening and to prevent leakage of the drink in the container after opening.

DESCRIPTION OF THE RELATED ART

[0002] A container for canned drinks in general distribution is equipped with a stay-on pull-tab, and the container is opened by lifting the pull-tab so that the pull-tab is separated from the top of the container, opening the can. However, once opened, the canned drinks cannot be closed. This may not be a problem if one drinks all the content, but it is difficult to carry the drink if drink is left over. Furthermore, the container with left-over drink therein may not even be discarded. Therefore, consumers have to consider whether they can consume all the drink before they drink outdoors. Thus, depending on the degree of thirst, the consumers often give up drinking.

[0003] Hence, the device disclosed in Japanese Laid Open Utility Model Publication No. Hei 5-46755 (Japanese Application for Utility Model No. Hei 3-104586) was a sealed lid for an opened container consisting of a flat top and a curved cylindrical side wall, wherein an annular skirt is placed inside of the cylindrical side wall, and the seam of a large-diameter can may be fitted between the cylindrical side wall and the annular skirt. Also, another annular skirt with a smaller diameter is placed inward from the annular skirt so that the seam of a can with a smaller diameter may be fitted,

[0004] On the other hand, in the design of a container for drinks, a seam is disposed at a higher place than the top face of the container, and furthermore, a thin groove is formed inside the whole perimeter of the seam. This thin groove is present between the seam and the tab for opening. The groove is formed as a necessary consequence of the seaming process, which connects a peripheral wall and a lid that compose a main body of the container, but it cannot be denied that the structure of the groove tends to allow invasion of dirt and dust before opening the container. Since an opening area, where the mouth is expected to touch when one drinks, is exposed in common canned drinks, it is difficult to maintain hygiene at the distribution stage. It has been pointed out that hygiene problems exist in that common bacteria on people's hands and the like might contaminate the opening area of the canned drinks, because employees of shops or customers may touch directly the opening area of the containers with their hands when the canned drinks are displayed or purchased.

[0005] Thus, an invention disclosed in the Japanese

Laid Open Patent Publication No. 9-207956 (Japanese Patent Application No. 8-38961) was a canned drink with a covering part consisting of a top part covering the top face of a container for canned drinks and a sealing part that is continuous from the top part and adheres to the side of the container, wherein the area of the container where the mouth contacts on drinking is covered thereby.

[0006] However, the former art, of the conventional arts described above, is useful to preserve the leftover drinks but does not maintain hygiene of the whole container for canned drinks at the distribution stage, because it is to be used for canned drinks after the purchase after distribution. The art described above is prepared for two kinds of cans, one of small and another of large diameter. However, the conventional art cannot deal with all cans, because the sizes of cans from manufacturers are slightly different from each other even if they are categorized in a single size group. Furthermore, the seam, at which a lid is attached on the peripheral wall of the container for canned drinks, is hard but, when dropped on a floor, the seam would be deformed easily and would no longer fit to the cover which is designed to attach to the seam.

[0007] On the other hand, the latter of the conventional arts described above can manage the maintenance of hygiene of the canned drinks at the distribution stage but cannot deal with problems of leftover drinks. By using both arts together, problems of the maintenance of hygiene of canned drinks at the distribution stage and the preservation of leftover drinks may be solved. However, using both the cover at the distribution stage and the hermetically sealed lid when drinking would increase costs for consumers. The consumers are expected to carry the hermetically sealed lid all the time in case they drink canned drinks, and when several canned drinks are opened at the same time, multiple hermetically sealed lids are needed. Different lids are needed for different kind of drinks because the smell of one drink may be transferred to another drink through the lid. Thus the consumers have to carry multiple hermetically sealed lids according to the number of different kinds of drinks they might consume.

[0008] US 5 139 163 describes a reclosable cover for a can which is flexible so that a hinge can operate. It does not, however, provide for a range of can or lid diameters. US 4 815 628 is a container sealer that forms a sleeve over cans of certain diameter.

OBJECT AND SUMMARY OF THE INVENTION

[0009] The object of the present invention is to solve the above mentioned problems and to provide a cap for canned drinks which can be used for various cans with slightly different diameters, and which can also be used for maintenance of hygiene of canned drinks at the distribution stage as well as for preservation of leftover drinks at the stage when consumers drink.

[0010] To achieve above mentioned objectives, a cap for canned drinks has been developed according to

claim 1. The gist of the present invention is a cap which is disposed around the top lid of a container for canned drinks consisting of: a seal face part composed in a film form that is capable of expanding and contracting, and covers the top of above mentioned container; and an outer-perimeter part made of an elastic material capable of expanding and contracting that surrounds the outer perimeter of the seal face part, wherein the whole top face of the container for canned drinks is covered water-tight with the seal face part by attaching the outer-perimeter part to the area below the seam of the container.

[0011] The seal face is made with sufficient flexibility and expansion ratio of its diameter of greater than or equal to 1:1.14 and the outer-perimeter part may be made with sufficient elasticity, by making them by injection molding as one piece structure using polystyrene or polypropylene. Further, the preferable flexibility and expandability of the seal face may be obtained by making the thickness of the seal equal to or below 0.4 mm, while the preferable elasticity of the outer-perimeter part may be obtained by making the wall thickness of the outer-perimeter part equal to or above 0.5 mm.

[0012] The cap for the container for canned drinks may be put on or off easily by disposing at least one tongue part that protrudes from the edge of the outer-perimeter part. Putting-on and -off the cap is made easy by disposing many small tongue as well as two tongues with large area.

[0013] A modified example of the invention described above is a cap disposed around a lid of a container for canned drinks consisting of: a seal face part composed in a film form that is capable of expanding and contracting, and covers the top of above mentioned container; an outer-perimeter part made of an elastic material capable of expanding and contracting that surrounds the outer perimeter of the seal face part; and a sealing part that is a continuation of the outer-perimeter part and adheres to a peripheral wall of the container for canned drinks, wherein the whole top area of the container for canned drinks is covered water-tight with the seal face part by attaching the outer-perimeter part to the area below the seam of the container. By this modification, canned drinks in the distribution stage may be better protected hygienically because the sealing part covers a large area of the upper part of the container for canned drinks

[0014] In this case also, the seal face part, the outer-perimeter part and the sealing part are made with sufficient flexibility and expandability by injection molding of polystyrene or polypropylene as a one piece structure. Especially the seal face part may be made sufficiently flexible and expandable with a thickness of the seal face part equal to or below 0.4 mm and the outer-perimeter part may be made sufficiently elastic with a wall thickness equal to or above 0.5 mm..

[0015] Further, a modification is a cap disposed around a lid of a container for canned drinks consisting of: a seal face part composed in a film form that is capable of ex-

panding and contracting, and covers the top of above mentioned container; and an outer-perimeter part made of an elastic material capable of expanding and contracting that surrounds the outer perimeter of the seal face part; a sealing part that is a continuation of the outer-perimeter part and adheres to a peripheral wall of the container for canned drinks; and an edge part composing a terminal edge of the sealing part, wherein the whole top area of the container for canned drinks is covered water-tight with the seal face part by attaching the outer-perimeter part to the area below the seam of the container. In this case adherence between the container for canned drinks and the sealing part may be made stronger by giving sufficient elasticity to the edge of the sealing part.

[0016] Particularly, all of the seal face part, outer-perimeter part, sealing part and edge part are composed of polystyrene or polyethylene as one unit by injection molding, wherein the seal face part and the sealing part possess sufficient flexibility and expandability, and the outer-perimeter part and the edge part possess sufficient elasticity, by making the thickness of the seal face part and the sealing part equal to or below 0.4 mm and the thickness of the outer-perimeter part and the edge part equal to 0.5 mm or above, and therefore the seal face part is stabilized by the elasticity of the outer-perimeter part, and the sealing part is stabilized by the elasticity of the edge part.

[0017] In an embodiment as another modification of the present invention, it is preferable that perforations are present at the border between the outer-perimeter part and the sealing part. These perforations are formed along the border line between the outer-perimeter part and the sealing part, wherein the preferred border line is a line forming the edge of the outer-perimeter part and an outline of the tongue parts projecting therefrom. Further, it is preferable that the sealing part contains the second perforations which are continuing from the perforations formed at the border between the outer-perimeter part and the sealing part, to the edge of the sealing part. At this point, a preferable composition is that the sealing part contains the second tongue part projecting from the edge near the second perforations. The second tongue part herein is a tongue part used for breaking the sealing part along the second perforations.

[0018] A further modification of the present invention is a cap disposed around a lid of a container for canned drinks consisting of: a main part of the cap including a seal face part in an expandable film form that covers the top of above mentioned container and an outer-perimeter part made of an elastic material capable of expanding and contracting that surrounds the outer perimeter of the seal face part; and a covering part which covers the lid and the peripheral wall of the container for canned drinks, wherein the whole top face area of the container for canned drinks is covered water-tight with the seal face by attaching the outer-perimeter part to a site below the seam of the container and at the same time, the cover

part covers the lid and the peripheral wall of the container for canned drinks to which the main part of the cap is attached.

[0019] Because the seal face part and the outer-perimeter part in this modified example are also made of polystyrene or polyethylene by injection molding as one piece, and the thickness of the seal face part is equal or below 0.4 mm and that of the outer-perimeter is equal to or over 0.5 mm, the seal face part has sufficient flexibility and ability of expanding and contracting and the outer-perimeter part has sufficient elasticity. Similarly, the disposition of at least one tongue part protruding from the edge of the outer-perimeter of the peripheral wall of the cap makes putting on and off the cap easier.

[0020] In the modified example described above, after the cover part is removed, only the main part of the cap (the cap for the container for canned drinks in the present invention) stays. Therefore, the perforations formed from one part of the edge of the cover part to suitable directions makes breaking off the cover part easy, and further by disposing the tongue part protruding from the edge of the cover part near these perforations, the cover part is broken off by the tongue part.

[0021] Since the top face of the container for canned drinks can be covered according to the invention described above, invasion of dirt, dust and the like into a groove formed on the top face may be prevented. Further, the disposition of the sealing part allows to cover the area on the peripheral wall of the container where consumers are expected to touch directly with their mouths, and even if distributors, sales personnel in shops or general consumers may touch the top face of the container, hygienic canned drinks may be provided. Further, the presence of the cap for canned drinks, or confirming that the sealing part is not removed makes it possible to determine instantaneously whether foreign bodies may be introduced into the canned drinks in the distribution stage, and thus the hygienic management in the distribution stage is benefited.

[0022] Further, the expandable construction of the seal face part and the outer-perimeter part of the cap for canned drinks allows repeated putting on and off of the cap. Thus, in the case there are leftover drinks in the container, the drinks can be hygienically preserved by applying the cap for canned drinks and the leftover drinks are prevented from spilling out because the seal face part can cover the whole top area water-tight.

[0023] Furthermore, as described above, the outer-perimeter part of the cap for canned drinks is capable of expansion and contraction, and therefore, when the outer-perimeter part is attached to the area below the seam of the container, it is not easily removed because of the contraction power of the outer-perimeter part, and the attachment is secured. Even if the diameter of the upper face of the container for canned drinks is slightly different from the standard, the difference may be absorbed by the contraction force of the outer-perimeter part. In this case, the condition that the seal face part covers the

whole top area of the container for canned drinks is not changed because the seal face part also contracts appropriately. Furthermore, in a container for canned drinks equipped with a stay-on pull tab, the top part of the pull tab may be lifted to a higher position after opening. In this case the seal face part may be stretched and deformed to a tent-like shape but the condition of the top area being covered as described above is not changed.

[0024] The above, and other objects, features and advantages of the present invention will become apparent from the following description read in conjunction with the accompanying drawings, in which like reference numerals designate the same elements.

15 BRIEF DESCRIPTION OF THE DRAWINGS

[0025]

Figs. 1(a)-1(c) illustrate an embodiment of the present invention.

Fig. 2 illustrate a mode of use of the above embodiment.

Figs. 3(a)-3(b) are perspective views showing a mode of the production of the cap for drinks in the above embodiment of the present invention.

Figs. 4(a)-4(b) are cross sections of the container for canned drinks used in the present invention. Fig. 4(a) shows the type I and Fig. 4(b) shows the type II of the container of canned drinks.

Fig. 5 illustrates a cross section view showing the condition wherein the above embodiment is used on the type II container for canned drinks.

Figs. 6(a)-6(d) illustrate the shapes of the perimeter part in the above embodiment when it is modified.

Fig. 7 shows a cross section view demonstrating the usage of the above embodiment.

Fig. 8 is a cross section view showing a stacked condition when the above embodiment is used.

Figs. 9(a)-9(b) illustrate modified examples of the above embodiment.

Figs. 10(a)-10(b) illustrate the usage modes of above mentioned modified example.

Fig. 11 illustrates another embodiment of the present invention.

Figs. 12(a)-12(b) illustrate modified examples of the embodiment.

Fig. 13 illustrates another modified example in which the embodiment is further modified.

Fig. 14 illustrates a further embodiment of the present invention.

Fig. 15 illustrates a modified example of the embodiment.

55 DETAILED DESCRIPTION OF THE PREFERRED EMBODIMENTS

[0026] In the embodiment of the present invention shown in Fig. 1, a seal face part 11 with an appropriate

area and an outer-perimeter part 12 which forms the outer perimeter of the seal face part 11 are constitutional elements. The seal face part 11 is composed of a material with the ability to expand and contract and is formed as a film with an appropriate elasticity. Similarly, the outer-perimeter part 12 is also composed of an elastic material with the ability to expand and contract. More concretely, the seal face part 11 is composed of polystyrene or polypropylene as one unit by injection molding, wherein the seal face part 11 is made thinner while the outer-perimeter part 12 is thicker. When the thickness of the seal face part 11 is made equal to or below 0.4 mm, reasonably good flexibility and ability to expand and contract are obtained. The thickness of 0.3 mm - 0.4 mm is appropriate and provides strength, but if flexibility is regarded more important, it may be changed to less than 0.3 mm easily. The expandability of the seal face part 11 means that it can expand and contract freely in vertical and horizontal directions, and the expansion ratio in terms of the area of the outer-perimeter part is equal to or more than 1:1.3. This is equivalent to 1:1.14 when converted to the ratio for the diameter. Since the diameter of the top of the small container for canned coffee drinks distributed in Japan is 52 mm, a seal face part with a diameter equal to or above 46 mm may be used for this kind of the container. The mode of attachment of the seal face part 11 to the container for coffee drink is shown in Fig. 2.

[0027] By forming the outer-perimeter part 12 in a ring shape and making the thickness 0.5 mm or more, expansion and contraction was possible and sufficient elasticity was obtained. The ring of the outer-perimeter part 12 applies pressure on the seal face part 11 evenly and is suitable for the container for canned drinks with a circular cross section. By making the seal face part 11 with polystyrene or polypropylene having a thickness of 0.1 - 0.4 mm, the original shape may be maintained without deformation of the whole structure while keeping a proper flexibility.

[0028] The cap for canned drinks made of polystyrene or polypropylene undergoes no change in flexibility, expandability or elasticity of the material even when left in an environment of 120°C. Thus a cap for drinks made of these materials may be used for a container for hot drinks. Naturally the cap for canned drinks made from the materials described above undergoes no change in flexibility and the like in an environment at 0 °C or below and therefore may be used for cold drinks. Further, substitute materials for the above described polystyrene or polypropylene include polyolefin and the like.

[0029] In the embodiment described above, the outer-perimeter 12 is affixed by being latched to a recess 22 formed below a seam 21. Since the outer-perimeter 12 is formed like a ring with sufficient elasticity, it may be attached to the seam 21 by stretching to increase the radius of the ring, and at the same time the seal face part 11 is enlarged in accordance with the increase of the diameter of the ring. The cap for canned drinks 10 is

stably attached to the container 20 by the outer-perimeter 12 engaging with the recess 22 formed below the seam 21, by the elasticity of the outer-perimeter 12 and by the latching action provided by the recess 22. The cap being attached in this way, the top face of the container for canned drinks 20 can be covered water-tight by making the surface of the seal face part 11 abut the upper end of the seam 21 of the container for canned drinks 20. The state of the can that is covered as described above is shown in Fig. 2.

[0030] A seal face part 11 and an outer-perimeter part 12, the configuration of which are shown in Fig. 3, are produced by modifying the process for producing described above, wherein the seal face part 11 and the outer-perimeter part 12 are composed as one unit by layering the outer-perimeter 12 along the outer perimeter edge of the seal face part 11. In this case, the elasticity of the seal face part 11 and that of the outer-perimeter part 12 may be changed to make a suitable expansion and contraction adjustment according to the size and variety of the container for canned drinks to which the caps for canned drinks 10 is attached. Further, it may be possible to make a very flexible film-like structure by making polystyrene or polypropylene used for the seal face 11 very thin. Still further the seal face 11 may be a thinly stretched film made of a rubber material such as synthetic rubber and the like, and the outer-perimeter part 12 may be a rubber band like structure made of a rubber material, and they may be composed separately, and similar functions may be obtained by adhering them together forming one unit.

[0031] A container for canned drinks 20 which uses the embodiment described is herein explained. A seam part 21 of the container for canned drinks 20 is a part for connecting a peripheral wall 22 and a lid 23 as one unit and is projected out sideways further than the peripheral wall 22, since the edges of the peripheral wall 22 and the lid 23 are layered on each other. Fig. 4 (a) shows a type I container for canned drinks, used mainly for coffee drinks distributed in Japan. Fig. 4 (b) shows a type II container for canned drinks widely used for drinks such as green tea, black tea, juice or the like in Japan. The seam part 21 is formed at the connecting site between the peripheral wall 22 and the lid 23 in either type of the container.

[0032] Thus, a recess is formed below the seam part 21 at the gap between the seam part 21 and the peripheral wall 22, and when the outer-perimeter part 12 is installed to the recess, the outer-perimeter part 12 latches on to the seam part 21. Since the recess is a ring-shaped structure formed around the whole perimeter of the container for canned drinks 20, the whole perimeter of the outer-perimeter part 12 is latched on to the,ring-shaped recess. This latching action is influenced by the contraction power of the outer-perimeter part 12, and the elastic power of a elastic material such as rubber and the like can provide enough power so that the cap for canned drinks 10 is not easily released. Further, the mode of the

cap for canned drinks 10 attached to the type I container for canned drinks is shown in Fig. 2 and the mode of the cap for canned drinks 10 attached to the type II container for canned drinks is shown in Fig. 5.

[0033] In using the structure for the container for canned drinks described above, the shape of the outer-perimeter part 12 may take various forms. Fig. 6 shows these modified examples. These examples include: a hook-like composition formed from the top edge of the outer-perimeter 12 to inside; the outer-perimeter part 12 formed with a semi-circular cross section; the outer-perimeter part 12 formed with a circular cross section; and the outer-perimeter part 12 on which rubber bands with a four-sided cross section are layered. In any one of these embodiments, the outer-perimeter part 12 is latched on by the elasticity of the outer-perimeter part 12 by being attached to the recess 22 under the seam part 21 of the container for canned drinks 20.

[0034] In the embodiment described above, by attaching the cap for the container for canned drinks 10 to the top face of the container for canned drinks 20 at the time of shipping out, the top face including the groove 24 formed therein may be covered, and invasion of dust and dirt to the groove 24 during the distribution stage may be prevented. Also, if a consumer removes the cap for canned drinks 10 after the purchase, the cap for canned drinks 10 may be reattached to the container for canned drinks 20 by covering the top face, and therefore not only the leftover drinks in the container can be kept hygienically but also spillover of the leftover drinks outside of the cap for canned drinks may be prevented even if the drink leaks out from the opening 25 of the container for canned drinks 20 due to shaking and the like while the container is carried around, because the seal face part 11 of the cap for canned drinks 10 is attached to the whole perimeter of the seam part 21 in a water-tight manner.

[0035] Furthermore, in a container for canned drinks 20 equipped with a stay-on pull-tab 26, the top part of the pull tab may be lifted after opening to a higher position than the upper edge of a seam part 21. In this case the seal face part 11 of the cap for canned drinks 10 may be stretched a little by the pull-tab 26 because the seal face part 11 of the cap for canned drinks 10 is expandable. Because of this the seal face part 11 forms a tent-like shape but there is no problem with reattaching the cap for canned drinks 10. The mode described above is shown in Fig. 7.

[0036] Since the cap for canned drinks 10 described above is made of polystyrene or polypropylene, even if the diameter of the container for canned drinks 20 may be varied, the cap can be adjusted accordingly. The same kind of containers for canned drinks made by other manufacturers may have differences of a few mm in the diameter. However, if the expansion ratio of the seal face part 11 is 1:1.14 in diameter basis, the seal face part 11 with a diameter of 50 mm can expand to 57 mm, and there is no problem of using the cap for the same kind of

containers made by other manufacturers which may have 2 - 3 mm variations in the diameter. Since the expansion ratio can be increased by making the seal face part 11 thinner, if there is a possibility of using the same kind of the container for canned drinks made by other manufacturers, the thickness of the seal face part 11 may be adjusted beforehand so that the cap may be applied to various containers for canned drinks.

[0037] Further, since the seal face part 11 and the outer-perimeter part 12 have the ability to expand and contract, they may be attached to and removed from the top face of the container for canned drinks 20 multiple times. However, when consumers drink canned drinks, the container for canned drinks is discarded after all the drink is consumed. Therefore the cap for canned drinks 10 serves its purpose by being able to be attached to and removed from the can only a few times. Consequently, it is possible to make the seal face part 11 relatively thin and to conserve materials in such a composition. Further, concerning to the expansion and contraction function of the seal face part 11 and the outer-perimeter part 12, the objective can be achieved by providing the seal face part 11 and the outer perimeter part 12 with enough expansion and contraction ability to be able to withstand a few attachments and removals from the canned drink. If the cap is to be used for canned drinks not shipped with the canned drink cap 10 and is to be used as a portable canned drink cap 10, it is of course necessary to use a material that can withstand repeated attachments and removals.

[0038] Still further, depending on the packaging and the distribution means, canned drinks may be stacked on top of each other. In this case the stacking described above is made possible because the seal face part 11 with suitable ability for expansion and contraction changes its shape easily. This mode is shown in Fig. 8. When the bottom of the container for canned drinks 20a stacked on top is engaged to the top face of the container below, the seal face part 11, in the middle between canned drinks 20a and 20b, changes shape. To make such a change possible, the thickness of polystyrene or polypropylene may be equal to or below 0.2 mm so that sufficient flexibility is obtained.

[0039] Next, a modified example of the embodiment described above is explained. In this modified example, tongue parts 17 and 18 are disposed, projecting outward from the edge of the outer-perimeter part 12 of the cap 10 for the container for canned drinks. This modified example is shown in Fig. 9. As long as the tongue parts 17 and 18 described above is projecting outward from the outer-perimeter part 12, the directions may be horizontal, or toward the bottom face of the container for canned drink, wherein the tongue parts are composed with a sufficient area so that the tongue parts may be picked up separate from the outer-perimeter 12 using fingers.

[0040] The mode of use of the modified example described above is shown in Fig. 10. When the modified example described above is used, the ring of the outer-

perimeter part 12 may be enlarged by pulling the tongue part 17 and 18 by pinching with fingers, making the attachment of the cap to the container for canned drinks easier. Also, when the attached cap for canned drinks 10 is to be removed, it is easily done because the outer-perimeter part 12 is easily enlarged by pulling either the

[0041] Next, the second embodiment is explained. This embodiment is shown in Fig. 11. According to this embodiment, the outer-perimeter part 12 of the first embodiment described above includes the sealing part 13, which is made like a film and makes the outer-perimeter part 12 stick to the surface of the peripheral wall 22 of the container for canned drinks, when the cap for the container for canned drinks 10 is attached to the container for canned drinks 20. This sealing part 13 is composed continuously with the outer-perimeter part 12, and the perforations 14 are formed at the border between the sealing part 13 and the outer-perimeter part 12. The outer-perimeter 12 may be separated from the sealing part 13 by cutting along the perforations 14. After separation of the sealing part 13, the remaining composition of the cap for canned drinks 10 is that of the above embodiment.

[0042] Thus, the cap for canned drinks 10 can cover the top face of the container for canned drinks 20 and the area around the seam part 21, and the sealing part 13 can cover the peripheral wall 22 of the container for canned drinks while the sealing part 13 is continuous with the cap for canned drinks. Since the area in the peripheral wall covered by the sealing part 13 is located at the place continuous with the seam part 21 of the cap for canned drinks, the area near the opening 25 of the container for canned drinks 20 where the mouth may contact is covered.

[0043] To open the cap for canned drinks 10, only the cap for canned drinks 10 is separated from the container for canned drinks 20 after cutting along the perforations 14 to break apart the outer-perimeter part 12 and the sealing part 13. It is possible to release the cap for canned drinks by separating the outer-perimeter part 12 from the area below the seam part 21 of the container for canned drinks 21 utilizing the elasticity of the outer-perimeter part 12 of the cap for canned drinks. Further, it is possible to harden only the sealing part 13 by heating using hot air and the like to make the cutting of the perforations easier.

[0044] Still further, the sealing part 13 may be removed from the surface of the container for canned drinks 20 by providing second perforations 15, which are continuous with the perforations 14 described above, over a range that extends to the edge of the sealing part 13. In this case, the location of the second perforations 15 and the method for cutting may be indicated to the consumer by providing a tongue part 16 projecting from the edge of the sealing part 13.

[0045] In the second embodiment described above, the attachment of the cap at the time of shipping of canned drinks may prevent invasion of dust and the like to the top face of the container for canned drinks, and

even if shop keepers and general customers in shops touch the area of the opening 25 of the container for canned drinks 20, hygienic canned drinks may be provided without a fear of contamination by various bacteria.

Since the remainder of the cap after the removal of the sealing part 13 is the same as the cap for canned drinks in the above embodiment, it is possible to remove the cap for opening and re-attach for covering the top face of the container for canned drinks 20 after opening.

[0046] In a modified example of the embodiment described above, the edge part 13a of the sealing part 13 is made into a thick structure to be more elastic. The shape is shown in Fig. 12. The edge part 13 a is composed of a thick material with a ring form because the edge of the sealing part 13 is a circle except the tongue part 16. The entire cap may be attached while the sealing part 13 adheres tightly to the surface of the container for canned drinks by such a composition. Further, in another modified example of the second embodiment described above, the perforation 14, which is added to the border between the outer-perimeter 12 of the cap for canned drinks and the sealing part 13, is composed so that the tongue parts 17 and 18 are formed by the cutting of the perforations 14. The configuration is shown in Fig. 13. In this modification, almost all the perforations 14 are on the border line between the outer-perimeter 12 and the sealing part 13 except the location where the tongue parts 17 and 18 are to be formed. Perforations in this location are composed as an arc so that the sealing part 13 side is cut into an arc-like shape when cut. Thus, by cutting along the perforations 14, the tongue part 17 and 18 are formed at the arc-like curve, and at the same time the outer-perimeter part 12 and the sealing part 13 is separated.

[0047] Next, another embodiment is explained. In the third embodiment, the sealing part 13 is composed as a separate part independent of the cap for canned drinks 10. After attaching the cap for canned drinks 10, which is described above as the first embodiment and a modification thereof, to a container for canned drinks 20, it may be composed in such a way that the sealing part 13 covers the container for canned drinks 20 including the cap for canned drinks described above. This embodiment is shown in Fig. 14.

[0048] The sealing part 13 in the embodiment as described above functions as a cover part, which can cover a lid 23 of the container for canned drinks 20 and a peripheral wall 22 at the same time, and may cover the whole can including the cap for canned drinks 10. Such a composition prevents the cap attached to the container for canned drinks from detaching easily in the distribution stage, and guarantees the safety for the drinks in the container.

[0049] Two parallel perforations 14 and 15 are disposed in the sealing part (covering part) 13 described above extending from the edge of the sealing part 13 toward the center, and the sealing part (covering part) 13 may be separated independently by cutting both of

the perforations 14 and 15 at the same time and removing the middle section between the two perforations 14 and 15. In this case, after removal of the sealing part (covering part) 13, only the cap for canned drinks 10 is attached to the container, and the appearance is the same as the first or the second embodiment. The composition and the like of the cap for canned drinks 10 are the same as described above.

[0050] Further, the cutting of the perforations 14 and 15 may be made easy by disposing a tongue part 16 between the two perforations 14 and 15. Still further, to make the cutting of the perforations easier, a hard material may be used for the sealing part (covering part) 13. At least after the attachment, composing the sealing part with a material with less elasticity makes the removal of the middle section easier, because when the middle section of the two perforations 14 and 15 is lifted up by holding the tongue part 16, the middle section does not pull the sealing part (covering part) 13. To compose such a sealing part (covering part) 13, a shrink film that is heat-shrinkable may be used.

[0051] In a modified example of this embodiment, the relative positioning of the sealing part (covering part) 13 and the cap for canned drinks 10 is reversed. That is, the sealing part (covering part) 13 covers a container for canned drinks from the top face of the container, and the cap for canned drinks 10 covers the sealing part (covering part) 13. This embodiment is shown in Fig. 15. In this embodiment, canned drinks may be opened by separating the cap for canned drinks 10 first and then removing the sealing part (covering part) 13. When the sealing part (covering part) 13 is attached to the container for canned drinks 20, by covering upper area of the container for canned drinks 20 first with a heat-shrinking material, the sealing part (covering part) 13 may cover the container for canned drinks by closely adhering to the outside shape. When the sealing part (covering part) 13 is applied, it is also effective to use a hot melt adhesive or the like to seal in a watertight manner. Because the outer-perimeter part 12 of the cap for canned drinks 10 is elastic, when the cap for canned drinks 10 is attached to the container for canned drinks 20 to which the sealing part (covering part) 13 is already attached, the outer-perimeter part 12 of the cap for canned drinks 10 may be latched to the seam part 21 of the container for canned drinks.

[0052] The embodiments of the present invention are as described above. However, many varying and different embodiments may be made within the scope of the present invention concept. For example, in the seal face part 11, a band-shaped sealing film may be layered on the location where the top of the seam part 21 may touch. In this case, the band-shaped film made of polyethylene is disposed inside of the outer-perimeter 12, and this may not only improve the sealing effect by the seal film but also make the recognition of the front or the back of the cap for canned drinks 10 easier.

[0053] The container for canned drinks is usually dis-

carded after the drinks in the container are consumed, and the container made of metal is melted and reused as a material for metal. On the other hand, the cap for canned drinks, if it is made of polystyrene or polypropylene, is degraded to water and carbon dioxide by burning, and therefore is an environmentally considerate product. Further, if materials for the each embodiment described above are composed of biodegradable ones, it is useful to prevent the generation of nondegradable wastes.

[0054] Having described preferred embodiments of the invention with reference to the accompanying drawings, it is to be understood that the invention is not limited to those precise embodiments, and that various changes and modifications may be effected therein by one skilled in the art without departing from the scope of the invention as defined in the appended claims.

Claims

1. A cap (10) for disposal around a lid (23) of a container for canned drinks (20) comprising:

a seal face part (11) made as a film to expand and contract to cover a top face of said container for canned drinks (20);

an outer-perimeter part (12) of expandable elastic material disposed on an outer perimeter of said seal face part (11);

wherein,

the expansion ratio of the diameter of said face seal part (11) is greater than or equal to 1:1.14; and

in use, an entire top face of said container for canned drinks (20) is covered in a water-tight manner by said seal face part (11) by attaching said outer-perimeter part (12) below a seam part (21) of said container for canned drinks (20).

2. The cap for canned drinks according to claim 1, wherein:

said seal face part (11) and outer-perimeter part (12) are made of at least one of polystyrene and polypropylene by injection molding as one unit; a thickness of said seal face part (11) is equal to 0.4 mm or less; and a thickness of said outer-perimeter part (12) is equal to 0.5 mm or greater.

3. The cap for canned drinks according to any of claims 1 or 2, wherein at least one tongue part (17, 18) is disposed projecting from an edge of said outer-perimeter part (12).

4. The cap (10) for canned drinks (20) according to claim 1 or 2, further including a sealing part (13) continuous with said outer-perim-

eter part (12) for adhering to a peripheral wall (22) of said container for canned drinks (20).

5. The cap (10) for canned drinks (20) according to claim 4, further including :
an edge part (13a) disposed on an edge of said sealing part (13).

6. The cap for canned drinks according to claim 5, wherein:

said sealing part (13) and edge part (13a) are made of at least one of polystyrene and polypropylene by injection molding as one unit;
a thickness of said sealing part is equal to 0.4 mm or less; and
a thickness of said edge part (13a) is equal to 0.5 mm or greater.

7. The cap for canned drinks according to any of claims 4 to 6, further comprising perforations (14) formed at a border between said outer-perimeter part (12) and said sealing part (13).

8. The cap for canned drinks according to claim 7, wherein:

said perforations (14) are formed along a borderline between said outer-perimeter part (12) and said sealing part (13); and
said borderline is a line disposed on an edge of said outer-perimeter part (12) and an outline of tongue parts (17, 18) projecting from said edge.

9. The cap for canned drinks according to any of claims 7 or 9, wherein said sealing part (13) is formed from a second perforation (15), extending continuously from said perforation (14), formed at said border between said outer-perimeter part (12) and said sealing part (13), to said edge of said sealing part (13).

10. The cap for canned drinks according to claim 9, wherein said sealing part (13) includes said second tongue part (16) which is projecting from said edge near said second perforations (15).

11. The cap for canned drinks according to claim 1, wherein said seal face part (11) is made as a film to expand and contract freely in vertical and horizontal dimensions.

12. The cap for canned drinks according to claim 11, wherein the thickness of said seal face part (11) is less than or equal to 0.2 mm.

Patentansprüche

1. Kappe (10) für Anordnung um einen Deckel (23) eines Behälters für Dosengetränke (20), umfassend:

einen Dichtungsflächenteil (11), hergestellt als eine Folie zum Ausdehnen und Zusammenziehen, um eine obere Fläche des Behälters für Dosengetränke (20) zu bedecken;

einen Außenumfangsteil (12) aus dehnbarem Elastikmaterial, angeordnet an einem Außenumfang des Dichtungsflächenteils (11);

wobei

das Expansionsverhältnis des Durchmessers des Flächendichtungsteils (11) größer als oder gleich 1:1,14 ist; und

in der Verwendung eine gesamte obere Fläche des Behälters für Dosengetränke (20) in einer wasserdichten Weise von dem Dichtungsflächenteil (11) abgedeckt wird, indem der Außenumfangsteil (12) unter einem Falzteil (21) des Behälters für Dosengetränke (20) angebracht wird.

2. Kappe für Dosengetränke nach Anspruch 1, wobei:

der Dichtungsflächenteil (11) und Außenumfangsteil (12) aus mindestens einem von Polystyren und Polypropylen durch Spritzgießen als eine Einheit hergestellt werden;

eine Dicke des Dichtungsflächenteils (11) gleich 0,4 mm oder weniger ist; und

eine Dicke des Außenumfangsteils (12) gleich 0,5 mm oder mehr ist.

3. Kappe für Dosengetränke nach einem der Ansprüche 1 oder 2, wobei mindestens ein Zungenteil (17, 18) hervorragend von einem Rand des Außenumfangsteils (12) angeordnet ist.

4. Kappe (10) für Dosengetränke (20) nach Anspruch 1 oder 2, weiter enthaltend einen Dichtungsteil (13), der fortlaufend mit dem Außenumfangsteil (12) ist, zum Anhaften an einer Umfangswand (22) des Behälters für Dosengetränke (20).

5. Kappe (10) für Dosengetränke (20) nach Anspruch 4, weiter enthaltend:

einen Randteil (13a), der an einem Rand des Dichtungsteils (13) angeordnet ist.

6. Kappe für Dosengetränke nach Anspruch 5, wobei:

der Dichtungsteil (13) und Randteil (13a) aus mindestens einem von Polystyren und Polypropylen durch Spritzgießen als eine Einheit her-

- gestellt werden;
eine Dicke des Dichtungsteils gleich 0,4 mm oder weniger ist; und
eine Dicke des Randteils (13a) gleich 0,5 mm oder mehr ist. 5
7. Kappe für Dosengetränke nach einem der Ansprüche 4 bis 6, weiter Perforationen (14) umfassend, die an einer Grenze zwischen dem Außenumfangsteil (12) und dem Dichtungsteil (13) gebildet sind. 10
8. Kappe für Dosengetränke nach Anspruch 7, wobei:
die Perforationen (14) entlang einer Grenzlinie zwischen dem Außenumfangsteil (12) und dem Dichtungsteil (13) gebildet sind; und 15
die Grenzlinie eine Linie ist, die an einem Rand des Außenumfangsteils (12) und einem Umriss des Zungenteils (17, 18), der von dem Rand her vorsteht, angeordnet ist. 20
9. Kappe für Dosengetränke nach einem der Ansprüche 7 oder 9, wobei der Dichtungsteil (13) aus einer zweiten Perforation (15) gebildet ist, die sich kontinuierlich von der Perforation (14), die an der Grenze zwischen dem Außenumfangsteil (12) und dem Dichtungsteil (13) gebildet ist, zu dem Rand des Dichtungsteils (13) erstreckt. 25
10. Kappe für Dosengetränke nach Anspruch 9, wobei der Dichtungsteil (13) den zweiten Zungenteil (16) enthält, der von dem Rand nahe den zweiten Perforationen (15) hervorsteht. 30
11. Kappe für Dosengetränke nach Anspruch 1, wobei der Dichtungsflächenteil (11) als eine Folie hergestellt wird, um sich frei in vertikalen und horizontalen Abmessungen auszudehnen und zusammenzuziehen. 35
12. Kappe für Dosengetränke nach Anspruch 11, wobei die Dicke des Dichtungsflächenteils (11) kleiner als oder gleich 0,2 mm ist. 40

Revendications 45

1. Capuchon (10) destiné à être disposé autour d'un couvercle (23) d'un contenant pour boissons en boîte (20) comprenant :
une partie face de scellement (11) réalisée sous forme de pellicule conçue pour se dilater et se contracter afin de couvrir une face supérieure dudit contenant pour boissons en boîte (20) ;
une partie périmètre externe (12) en une matière élastique expansible qui est disposée sur un périmètre externe de ladite partie face de scellement (11) ; 50
- cas dans lequel
le rapport d'expansion du diamètre de ladite partie face de scellement (11) est supérieur ou égal à 1:1,14 ; et
en utilisation, une face supérieure entière dudit contenant pour boissons en boîte (20) est recouverte de manière étanche à l'eau par ladite partie face de scellement (11) en attachant ladite partie périmètre externe (12) sous une partie cordon (21) dudit contenant pour boissons en boîte (20). 55
2. Capuchon pour boissons en boîte selon la revendication 1,
lesdites partie face de scellement (11) et partie périmètre externe (12) étant réalisées en une au moins des substances suivantes, à savoir polystyrène et polypropylène, grâce à un processus de moulage par injection sous forme d'une seule unité ;
une épaisseur de ladite partie face de scellement (11) étant égale à 0,4 mm ou à une valeur inférieure ;
et
une épaisseur de ladite partie périmètre externe (12) étant égale à 0,5 mm ou à une valeur supérieure.
3. Capuchon pour boissons en boîte selon l'une quelconque des revendications 1 ou 2, au moins une partie languette (17, 18) étant disposée pour faire saillie à partir d'un bord de ladite partie périmètre externe (12).
4. Capuchon (10) pour boissons en boîte (20) selon la revendication 1 ou 2, comprenant en outre :
une partie scellement (13) laquelle est continue avec ladite partie périmètre externe (12) afin d'adhérer à une paroi périphérique (23) dudit contenant pour boissons en boîte (20).
5. Capuchon (10) pour boissons en boîte (20) selon la revendication 4, comprenant en outre :
une partie bord (13a) laquelle est disposée sur un bord de ladite partie scellement (13).
6. Capuchon pour boissons en boîte selon la revendication 5,
lesdites partie scellement (13) et partie bord (13a) étant réalisées en une au moins des substances suivantes, à savoir polystyrène et polypropylène, grâce à un processus de moulage par injection sous forme d'une seule unité ;
une épaisseur de ladite partie scellement étant égale à 0,4 mm ou à une valeur inférieure ;
et
une épaisseur de ladite partie bord (13a) étant égale à 0,5 mm ou à une valeur supérieure.
7. Capuchon pour boissons en boîte selon l'une quel-

conque des revendications 4 à 6, comprenant en outre des perforations (14) qui sont formées au niveau d'une limite entre ladite partie périmètre externe (12) et ladite partie scellement (13).

5

- 8.** Capuchon pour boissons en boîte selon la revendication 7, lesdites perforations (14) étant formées le long d'une ligne limite entre ladite partie périmètre externe (12) et ladite partie scellement (13) ; et ladite ligne limite étant une ligne qui est disposée sur un bord de ladite partie périmètre externe (12) et un contour des parties languette (17, 18) faisant saillie à partir dudit bord.

10

15

- 9.** Capuchon pour boissons en boîte selon l'une quelconque des revendications 7 ou 9, ladite partie scellement (13) étant formée depuis une deuxième perforation (15), s'étendant en continu depuis ladite perforation (14), formée au niveau de ladite limite entre ladite partie périmètre externe (12) et ladite partie scellement (13), jusqu'audit bord de ladite partie scellement (13).

20

- 10.** Capuchon pour boissons en boîte selon la revendication 9, ladite partie scellement (13) englobant ladite deuxième partie languette (16) qui fait saillie depuis ledit bord à proximité desdites deuxième perforations (15).

25

30

- 11.** Capuchon pour boissons en boîte selon la revendication 1, ladite partie face de scellement (11) étant réalisée sous forme de pellicule conçue pour se dilater et se contracter librement suivant des dimensions verticales et horizontales.

35

- 12.** Capuchon pour boissons en boîte selon la revendication 11, l'épaisseur de ladite partie face de scellement (11) étant inférieure ou égale à 0,2 mm.

40

45

50

55

Fig. 1(a)

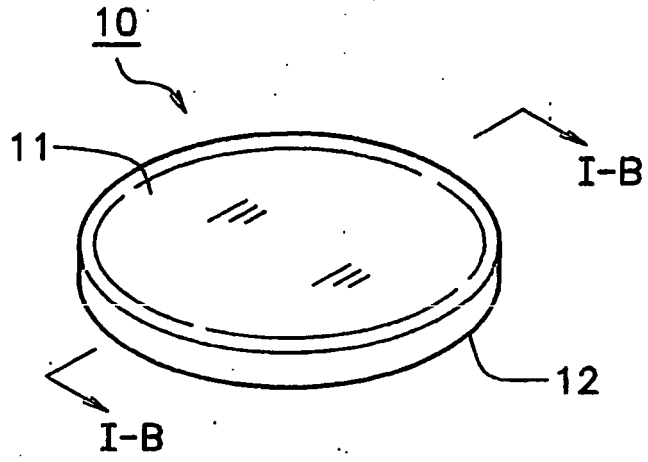

Fig. 1(b)

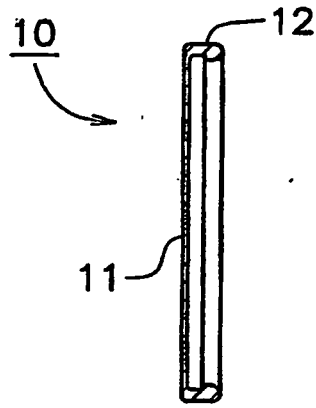

Fig. 1(c)

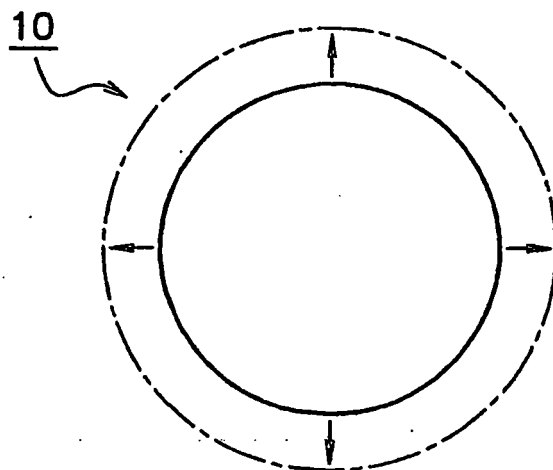

Fig. 2

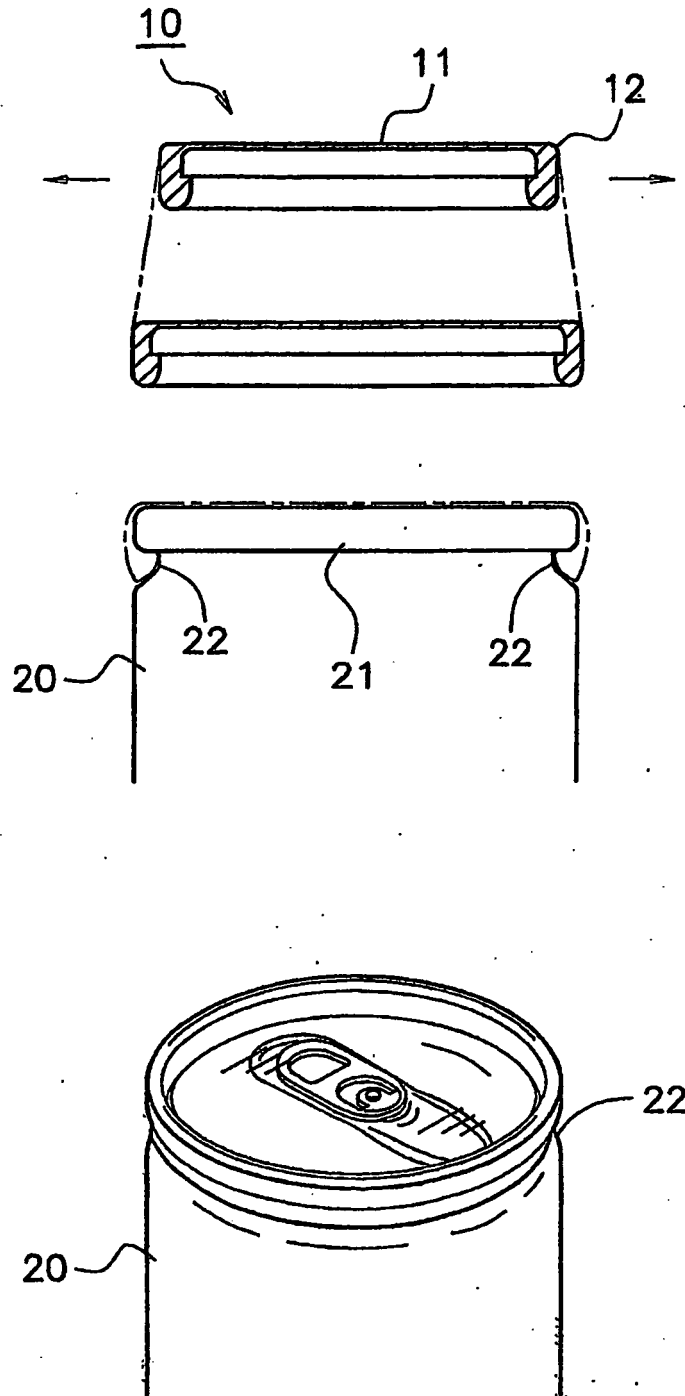

Fig. 3(a)

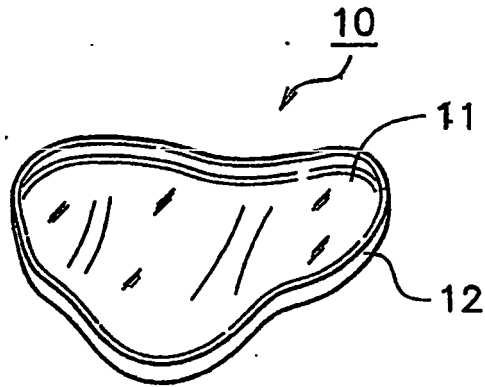

Fig. 3(b)

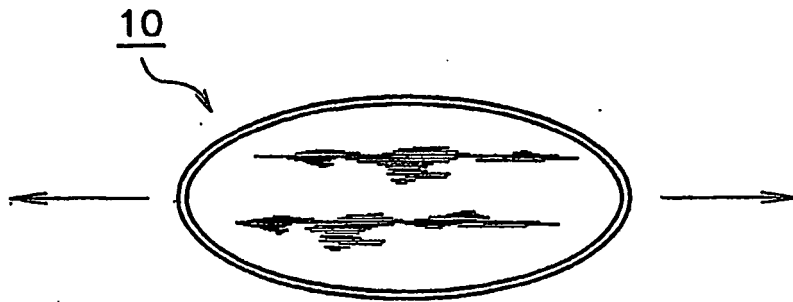

Fig. 4(a)

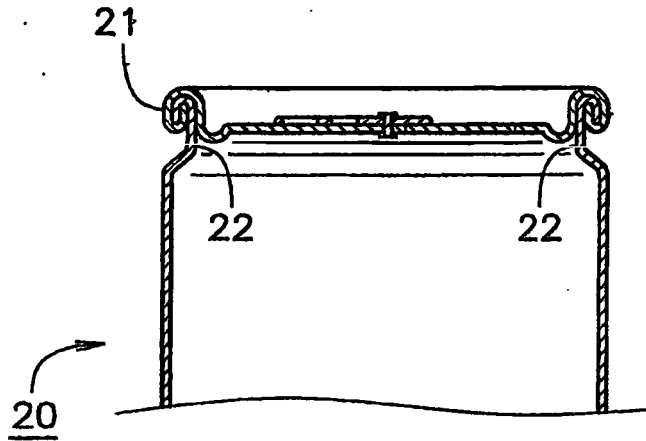

Fig. 4(b)

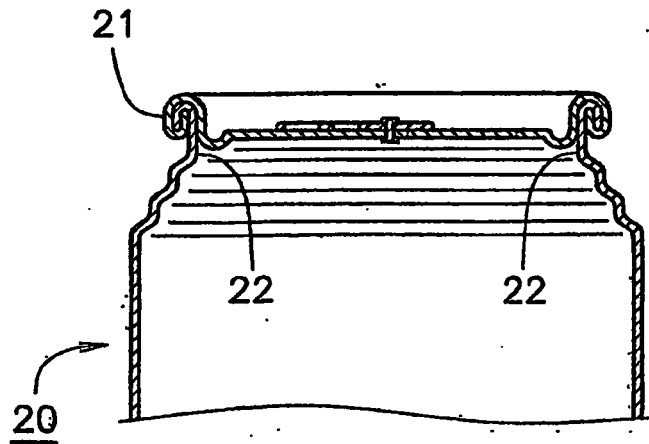
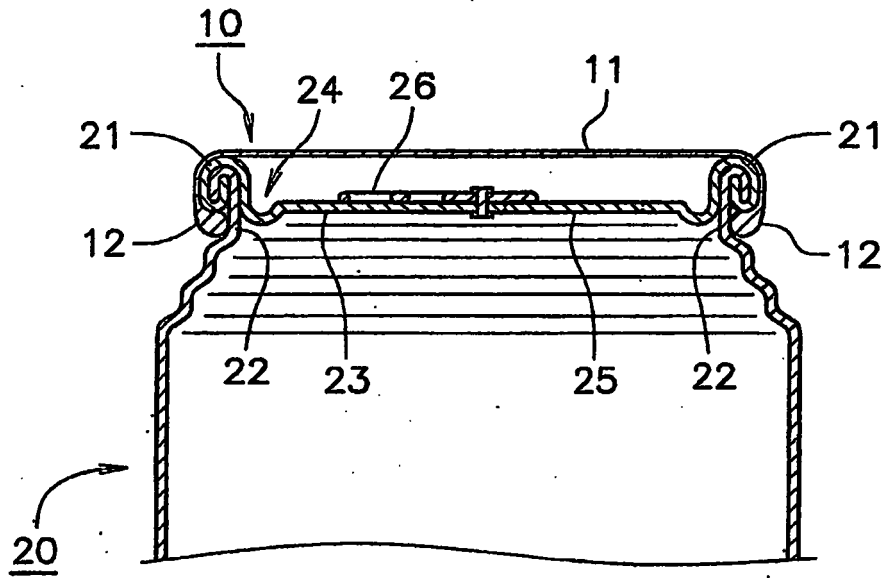

Fig. 5



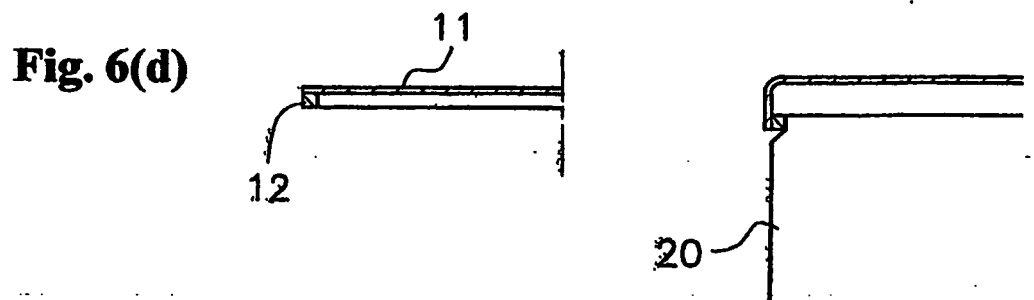
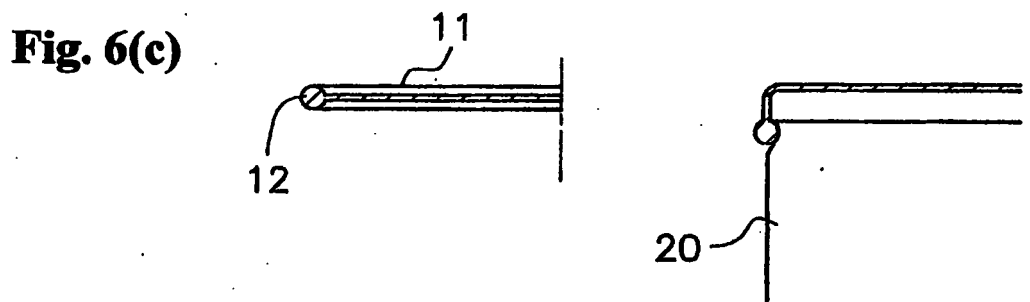
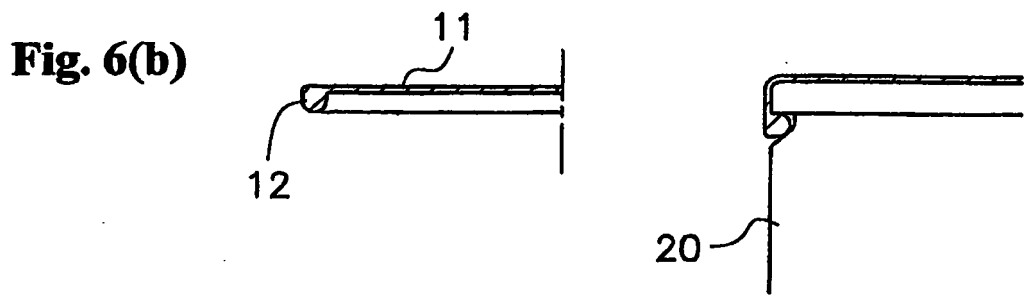
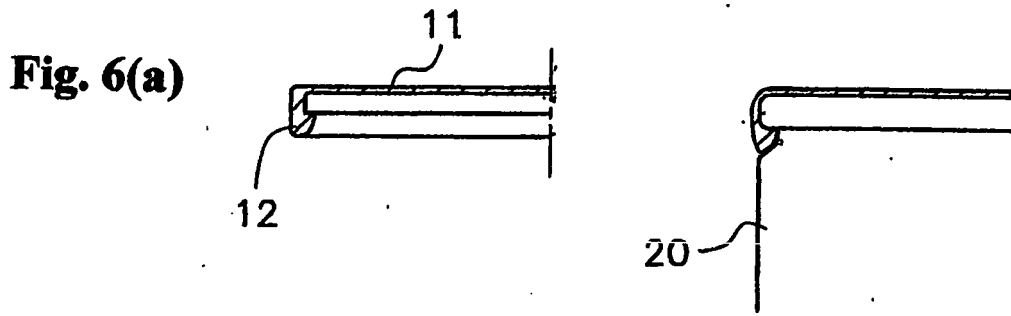

Fig. 7

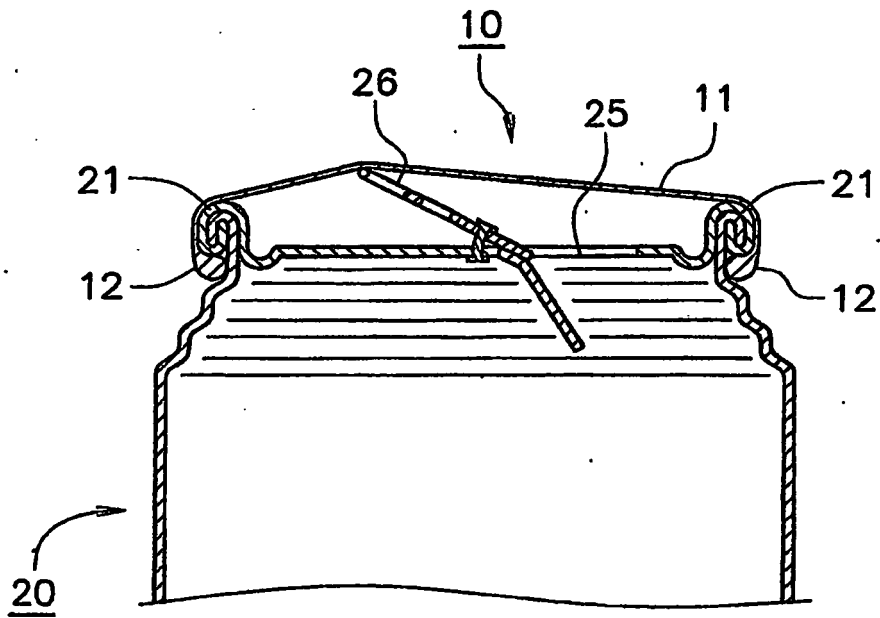

Fig. 8

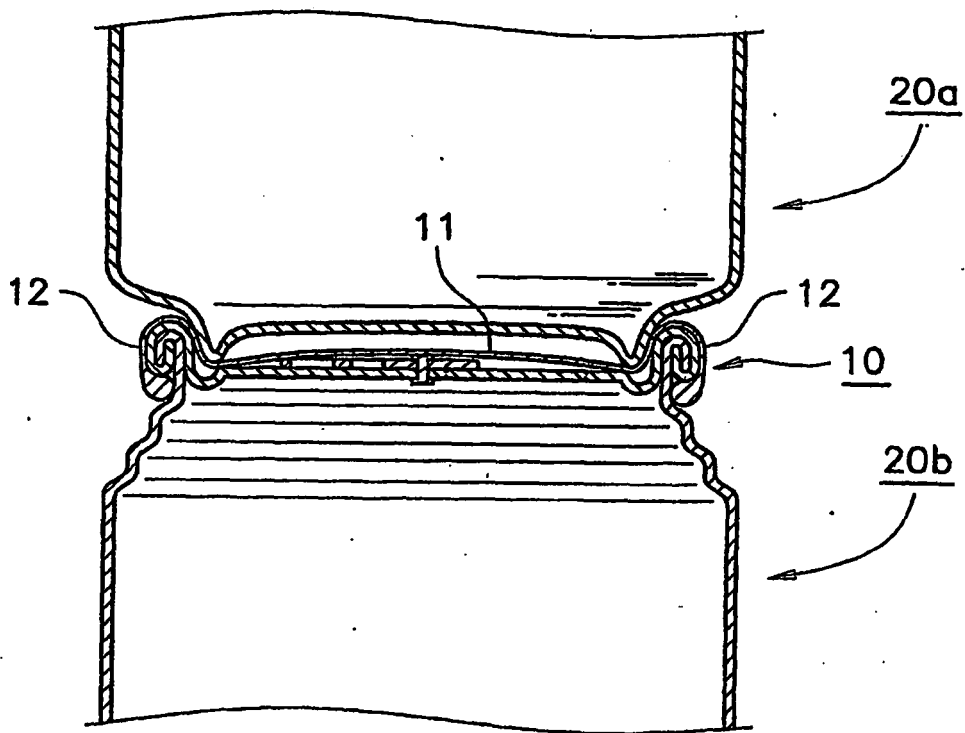

Fig. 9(a)

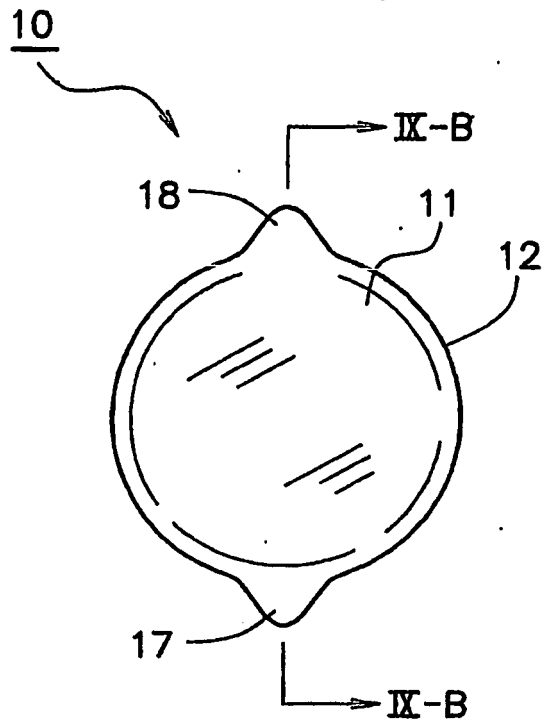

Fig. 9(b)

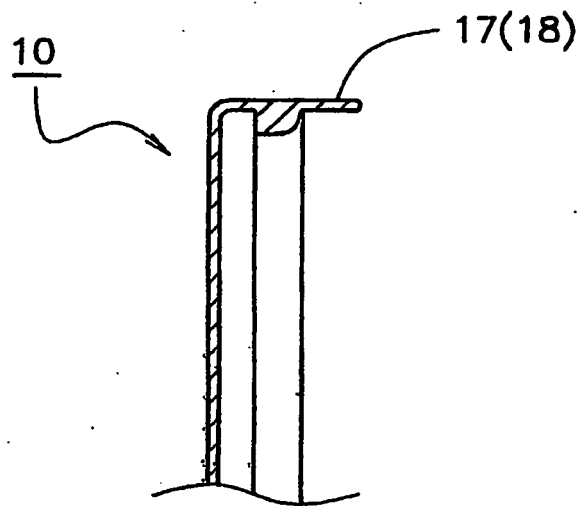

Fig. 10(a)

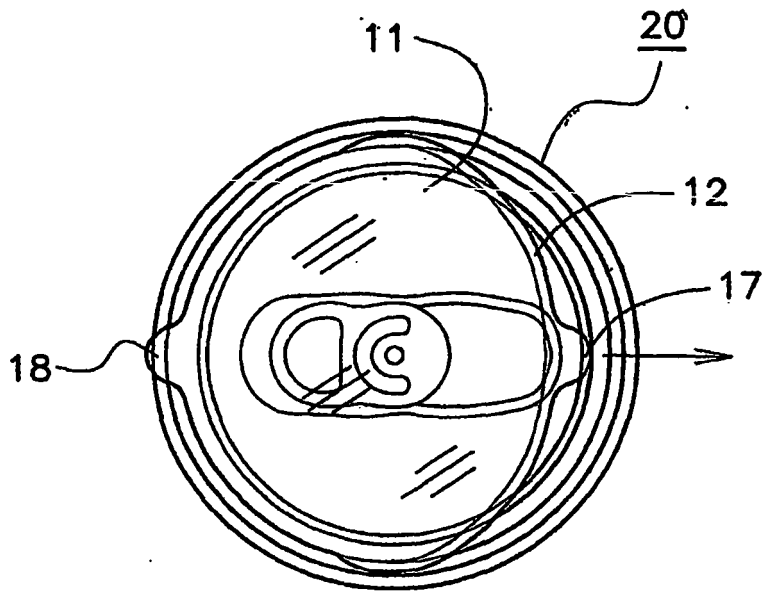

Fig. 10(b)

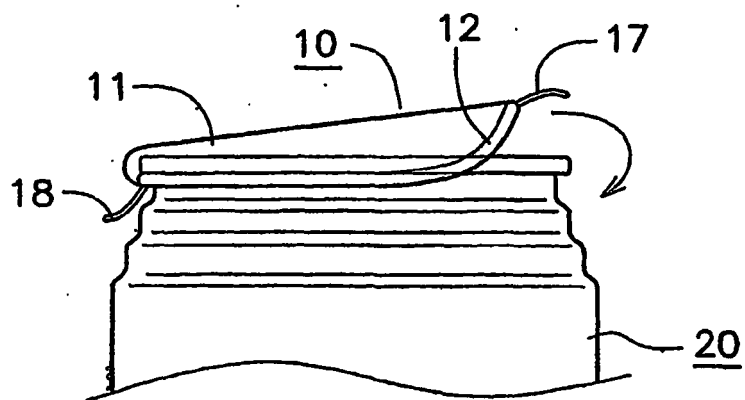

Fig. 11

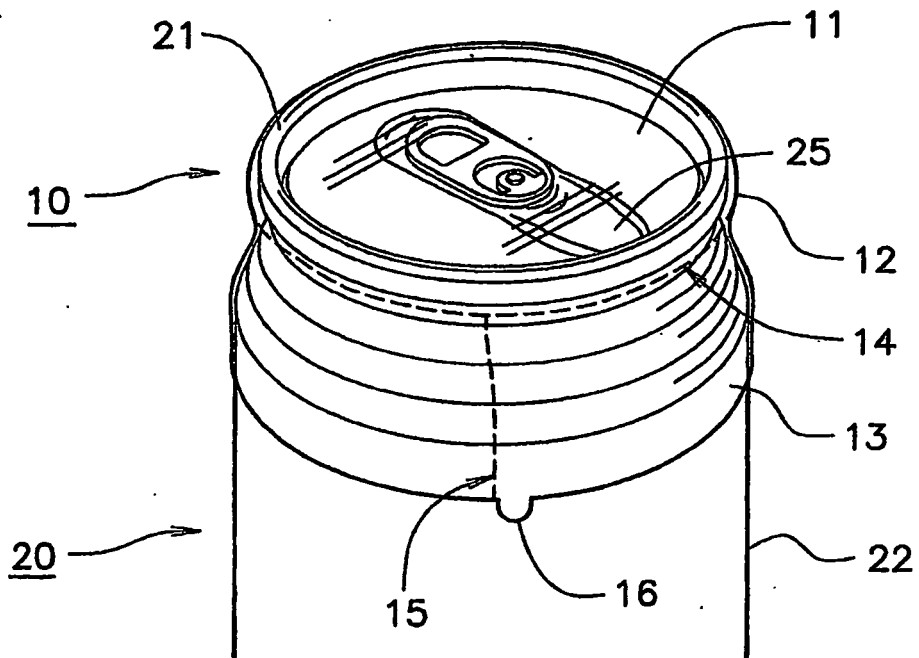

Fig. 12(a)

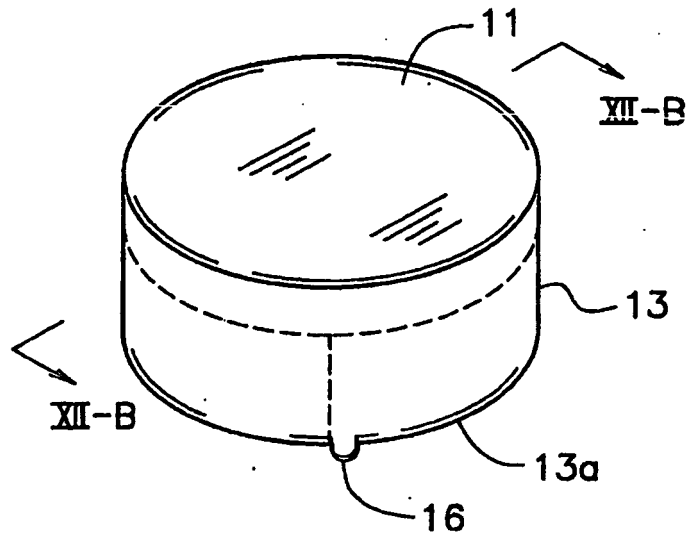

Fig. 12(b)

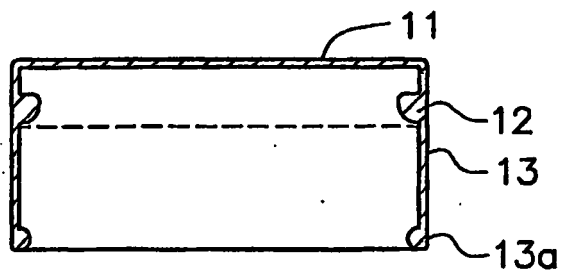

Fig. 13

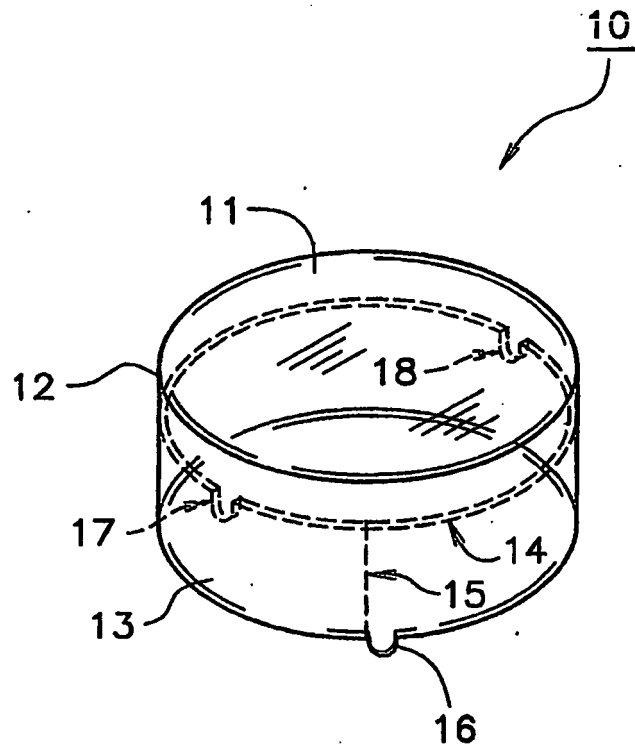

Fig. 14

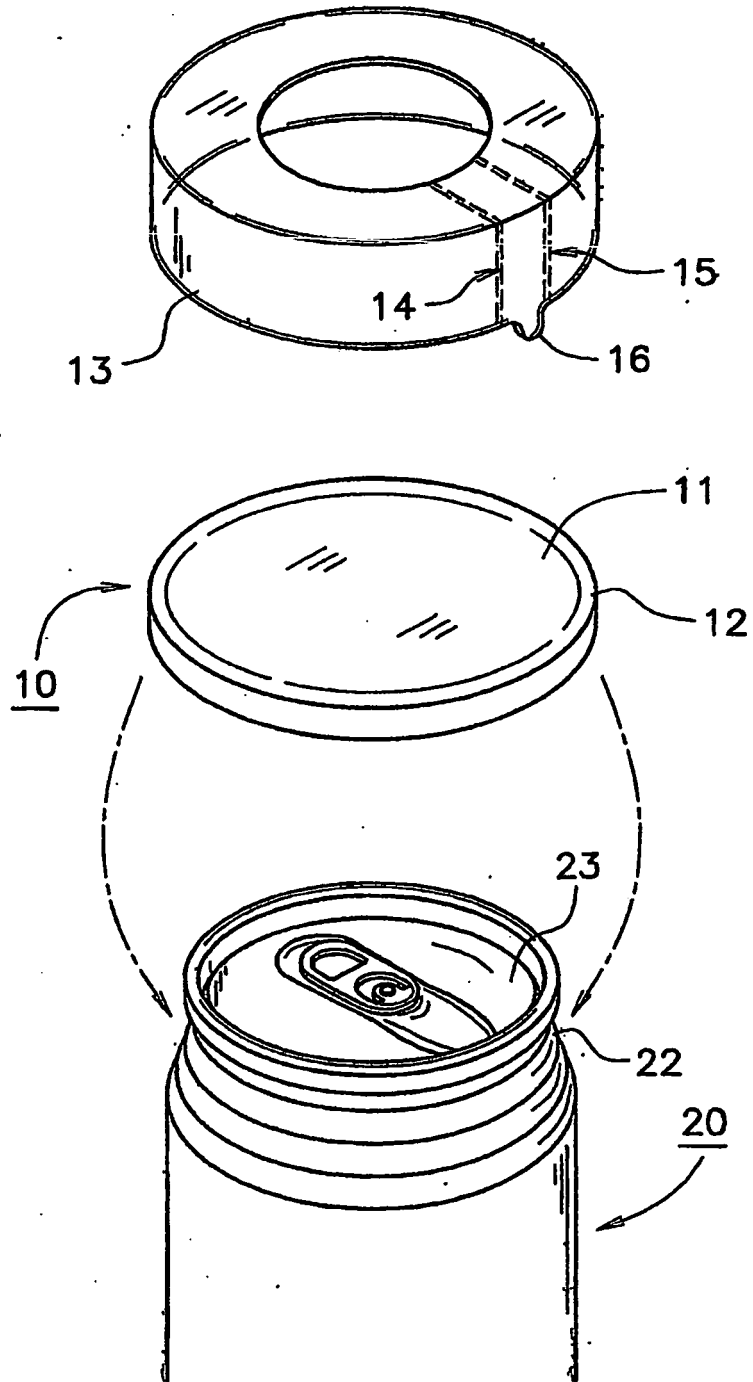
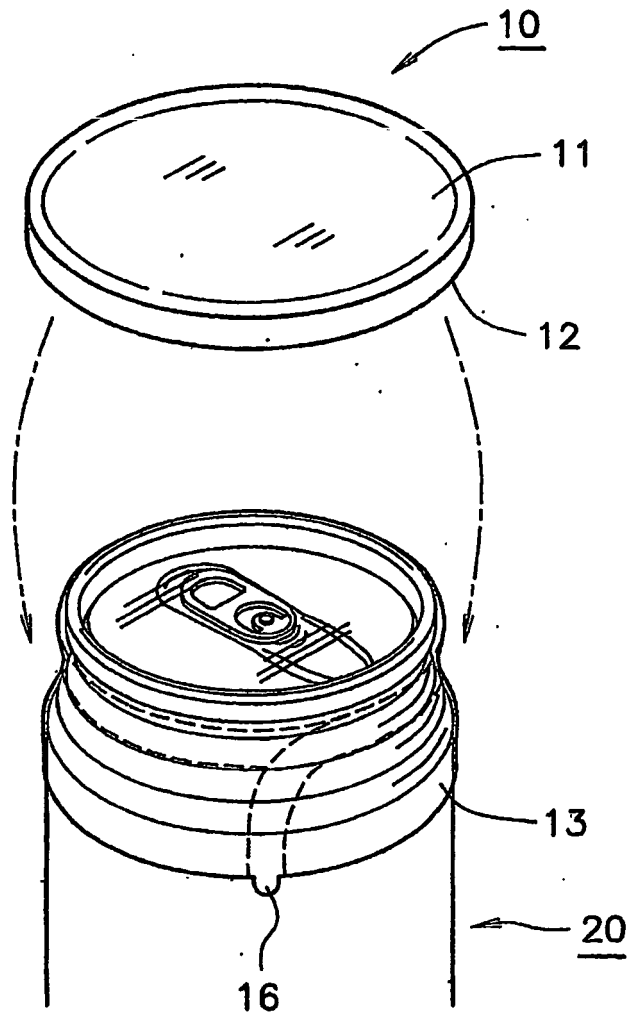

Fig. 15



REFERENCES CITED IN THE DESCRIPTION

This list of references cited by the applicant is for the reader's convenience only. It does not form part of the European patent document. Even though great care has been taken in compiling the references, errors or omissions cannot be excluded and the EPO disclaims all liability in this regard.

Patent documents cited in the description

- JP HEI546755 B [0003]
- JP HEI3104586 B [0003]
- JP 9207956 A [0005]
- JP 8038961 A [0005]
- US 5139163 A [0008]
- US 4815628 A [0008]