

(12) **UK Patent Application** (19) **GB** (11) **2540497** (13) **A**

(43) Date of Reproduction by UK Office **18.01.2017**

(21) Application No: **1618034.1**  
 (22) Date of Filing: **23.04.2015**  
 Date Lodged: **25.10.2016**  
 (30) Priority Data:  
 (31) **61987455** (32) **01.05.2014** (33) **US**  
 (86) International Application Data:  
**PCT/US2015/027374 En 23.04.2015**  
 (87) International Publication Data:  
**WO2015/167933 En 05.11.2015**

(51) INT CL:  
**G01V 3/30** (2006.01) **E21B 47/12** (2012.01)  
**E21B 49/00** (2006.01) **G01V 3/38** (2006.01)  
 (56) Documents Cited:  
**WO 2013/052049 A1** **WO 2012/005737 A1**  
**US 6294917 B1** **US 20040149434 A1**  
**US 20020000808 A1**  
 (58) Field of Search:  
 INT CL **E21B, G01V**  
 Other: **eKOMPASS (KIPO internal)**

(71) Applicant(s):  
**Halliburton Energy Services, Inc.**  
**3000 N. Sam Houston Parkway East,**  
**Houston 77032-3219, Texas, United States of America**  
 (72) Inventor(s):  
**Michael S. Bittar**  
**Clive D Menezes**  
 (74) Agent and/or Address for Service:  
**A A Thornton & Co**  
**10 Old Bailey, LONDON, EC4M 7NG, United Kingdom**

(54) Title of the Invention: **Interwell tomography methods and systems employing a casing segment with at least one transmission crossover arrangement**  
 Abstract Title: **Interwell tomography methods and systems employing a casing segment with at least one transmission crossover arrangement**

(57) An interwell tomography method includes casing a first borehole with a casing tubular having at least one transmission crossover arrangement, each transmission crossover arrangement having an adapter in communication with a coil antenna that encircles an exterior of the casing tubular. The method also includes deploying, inside the casing tubular, a conductive path that extends from a surface interface to the at least one transmission crossover arrangement. The method also includes providing a set of one or more antennas in a second borehole. The method also includes obtaining electromagnetic (EM) measurements for interwell tomography using the at least one transmission crossover arrangement and the set of one or more antennas, where said obtaining involves conveying data or power between the at least one transmission crossover arrangement and the surface interface via the conductive path.

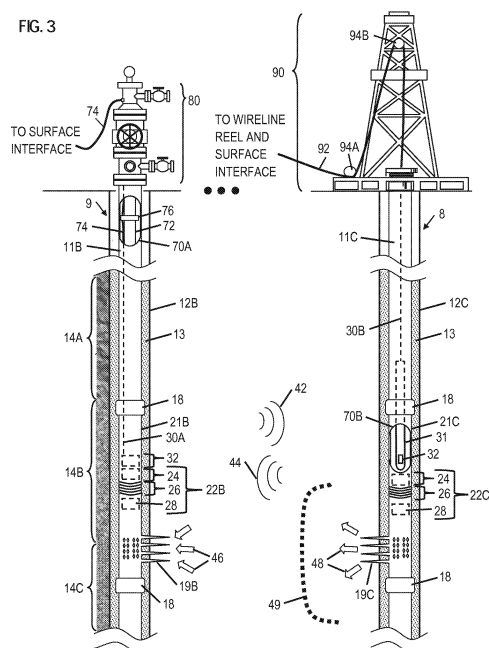

**GB 2540497 A**