

(19) World Intellectual Property Organization
International Bureau



(43) International Publication Date
24 April 2003 (24.04.2003)

PCT

(10) International Publication Number
WO 03/034632 A2

- (51) International Patent Classification⁷: H04L
- (21) International Application Number: PCT/US02/31858
- (22) International Filing Date: 4 October 2002 (04.10.2002)
- (25) Filing Language: English
- (26) Publication Language: English
- (30) Priority Data:

09/981,031	17 October 2001 (17.10.2001)	US
09/978,890	17 October 2001 (17.10.2001)	US
09/982,271	17 October 2001 (17.10.2001)	US
09/982,279	17 October 2001 (17.10.2001)	US
09/981,476	17 October 2001 (17.10.2001)	US

Stanley; 3 Wild Plum Court, Lemont, IL 60439 (US). **RAKERS, Patrick, L.**; 21746 Andover Road, Kildeer, IL 60047 (US). **KUHLMAN, Douglas, A.**; 1447 Ashwood Court, Elgin, IL 60123 (US). **MESSERGES, Thomas, S.**; 151 Brookstone Drive, Schaumburg, IL 60193 (US). **EASTMOND, Bruce, C.**; 5931 Brookbank Road, Downers Grove, IL 60516 (US).

(74) Agents: **DAVIS, Valerie, M.** et al.; Motorola, Inc., Intellectual Property Dept., 1303 East Algonquin Road, Schaumburg, IL 60196 (US).

(81) Designated States (*national*): AE, AG, AL, AM, AT, AU, AZ, BA, BB, BG, BR, BY, BZ, CA, CH, CN, CO, CR, CU, CZ, DE, DK, DM, DZ, EC, EE, ES, FI, GB, GD, GE, GH, GM, HR, HU, ID, IL, IN, IS, JP, KE, KG, KP, KR, KZ, LC, LK, LR, LS, LT, LU, LV, MA, MD, MG, MK, MN, MW, MX, MZ, NO, NZ, OM, PH, PL, PT, RO, RU, SD, SE, SG, SI, SK, SL, TJ, TM, TN, TR, TT, TZ, UA, UG, UZ, VC, VN, YU, ZA, ZM, ZW.

- (71) Applicant: **MOTOROLA, INC.** [US/US]; 1303 East Algonquin Road, Schaumburg, IL 60196 (US).
- (72) Inventors: **GURNEY, David, P.**; 1664 Howard Avenue, Des Plaines, IL 60018 (US). **KUFFNER, Stephen, L.**; 940 Applewood Lane, Algonquin, IL 60102 (US). **COLLINS, Timothy, James**; 14006 Christina Lane, Lockport, IL 60441 (US). **RACHWALSKI, Richard,**

(84) Designated States (*regional*): ARIPO patent (GH, GM, KE, LS, MW, MZ, SD, SL, SZ, TZ, UG, ZM, ZW), Eurasian patent (AM, AZ, BY, KG, KZ, MD, RU, TJ, TM), European patent (AT, BE, BG, CH, CY, CZ, DE, DK, EE, ES, FI, FR, GB, GR, IE, IT, LU, MC, NL, PT, SE, SK,

[Continued on next page]

(54) Title: METHOD AND DEVICE FOR DATA COMMUNICATION IN A MULTI-USER SYSTEM

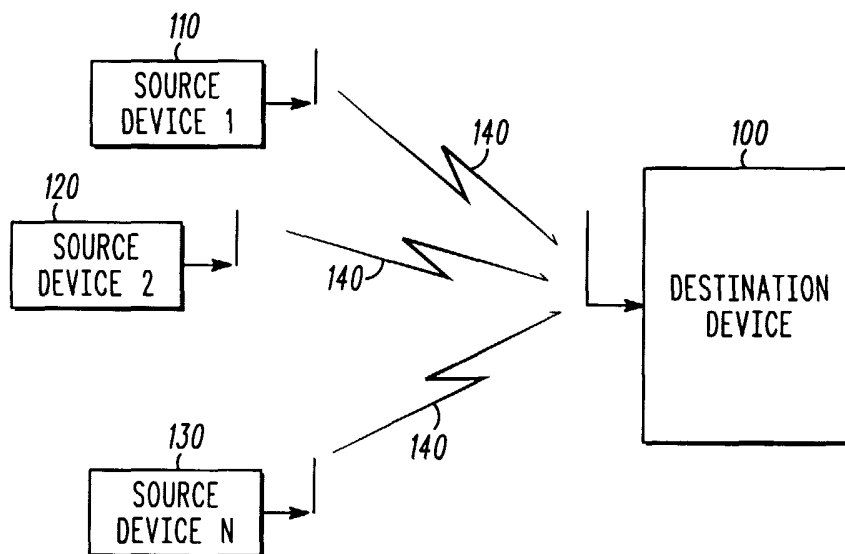

(57) Abstract: A communications method and device that enables multiple source devices (110, 120, 130) to communicate information to a destination device (100) is disclosed. The information communicated from any source device to the destination device (100) typically takes the form of binary electronic product codes ("EPC") or identification ("ID") information. The preferred embodiment of the invention utilizes the techniques of: data scrambling and descrambling; channel selection and transmission; enabling and disabling group transmissions; correlation; and collision mitigation.



WO 03/034632 A2



TR), OAPI patent (BF, BJ, CF, CG, CI, CM, GA, GN, GQ, GW, ML, MR, NE, SN, TD, TG).

For two-letter codes and other abbreviations, refer to the "Guidance Notes on Codes and Abbreviations" appearing at the beginning of each regular issue of the PCT Gazette.

Published:

— *without international search report and to be republished upon receipt of that report*

METHOD AND DEVICE FOR DATA COMMUNICATION IN A MULTI-USER SYSTEM

Reference to Related Applications

5 The present application is related to the following U.S. applications
commonly owned together with this application by Motorola, Inc.:

 Serial no. 09/981,031, filed October 17, 2001, titled "Channel
Selection Method Used in a Communication System" by Gurney, et al.
(attorney docket no. CM01960G);

10 Serial no. 09/978,890, filed October 17, 2001, titled "A Method of
Scrambling and Descrambling Data in a Communication System" by
Kuhlman et al. (attorney docket no. CM01962G);

 Serial no. 09/982,271, filed October 17, 2001, titled "A Correlation
Method used in a Communication System and Apparatus" by Gurney et al.
15 (attorney docket no. CM01968G);

 Serial no. 09/982,279, filed October 17, 2001, titled "Collision
Mitigation Methods used in a Communication System" by Kuffner et al.
(attorney docket no. CM01969G); and

 Serial no. 09/981,476, filed October 17, 2001, titled "Method and
20 Device for Enabling and Disabling Group Transmissions" by Collins et al.
(attorney docket no. IND10254).

Field of the Invention

 The present invention relates generally to a METHOD AND DEVICE
25 FOR DATA COMMUNICATION IN A MULTI-USER SYSTEM.

Background of the Invention

 A fast, efficient and reliable means of communicating data in a multi-user
system is desirable for many applications. A need for such methods arises when
30 multiple pieces of data (from multiple sources) need to be quickly read by a

receiver. One particular application of such technology is in the electronic identification of multiple items.

The electronic identification industry is important for numerous commercial and military applications, including real-time item tracking and inventory. Such uses can greatly increase operational efficiency in a myriad of scenarios, including virtually all of those involving some form of manufacturing, warehousing, distribution and retail. The ability to quickly and efficiently perform accurate real-time inventory tracking can greatly reduce waste in many forms, including, but not limited to, the misplacement of items, over- or under- stocking of items, and item theft.

Currently, the electronic identification industry relies heavily on manual (light-based) scanning to identify a plurality of items, where each item is assigned a product code. The Universal Product Code (UPC) system is currently in widespread use throughout the United States retail industry. Manually scanning items, however, is extremely time-consuming and highly prone to human error.

Thus, there exists a need to provide a method for efficient and reliable transmission of data from multiple sources to a receiver.

Brief Description of the Figures

The present invention is now described, by way of example only, with reference to the accompanying figures in which like references indicate similar elements and in which:

FIG. 1 illustrates a high-level view of multiple source devices communicating with a single destination device in accordance with the present invention;

FIG. 2 illustrates how data stored on a tag is altered and used to determine communications channels while operating in accordance with the present invention;

FIG. 3 illustrates a high-level view of the process used to scramble the stored data on a tag in accordance with the present invention;

FIG. 4 illustrates a high-level system view of multiple tag communications and the scrambling reversal (descrambling method) performed in the reader in accordance with the present invention;

FIG. 5 illustrates the iterative algorithms used to scramble and recover the tag data in accordance with the present invention;

FIG. 6 illustrates a detailed example of the scrambling procedure in accordance with the present invention;

FIG. 7 illustrates a high-level block diagram of a tag in accordance with the present invention;

FIG. 8 illustrates a general flowchart outlining tag transmission conditions in accordance with the present invention;

FIG. 9 illustrates a detailed flowchart outlining tag transmission conditions in accordance with the present invention;

FIG. 10 illustrates an application using capacitive coupling between the reader and a variety of tags in a typical embodiment in accordance with the present invention;

FIG. 11 illustrates a method of generating a channel for the tag to communicate over based on the data stored on the tag in accordance with the present invention;

FIG. 12 illustrates a simplified tag circuitry functional block diagram highlighting the pass dependence and modulation method in accordance with the present invention;

FIG. 13 illustrates a detailed view of the reader block diagram in accordance with the present invention;

FIG. 14 illustrates an example of fast transform methods for Walsh coded signals in accordance with the present invention;

FIG. 15 illustrates a detailed example of the reader receiver signal processing for fast correlation of pseudonoise sequences in accordance with the present invention;

FIG. 16 illustrates a simplified functional block diagram of the reader

signal processing in accordance with the present invention;

FIG. 17 illustrates an example waveform in the presence of a collision in accordance with the present invention;

FIG. 18 illustrates several example waveforms in the absence of collisions
5 in accordance with the present invention;

FIG. 19 illustrates a general flowchart for the reader actions in accordance with the present invention;

FIG. 20 illustrates a detailed flowchart of a reader processing signals using forward collision mitigation techniques in accordance with the present invention;

10 FIG. 21 illustrates an example inventory accounting with no collision mitigation techniques applied in accordance with the present invention;

FIG. 22 illustrates an example flowchart of the inventory algorithm when no collision mitigation techniques are applied in accordance with the present invention;

15 FIG. 23 illustrates an example inventory accounting with forward collision mitigation techniques in accordance with the present invention; and

FIG. 24 illustrates an example inventory accounting with bi-directional collision mitigation techniques in accordance with the present invention.

20 Detailed Description of the Present Invention

The present invention discloses an improved communications method that allows multiple source devices to quickly and efficiently communicate information to a destination device. The described communications system employs a combination of several techniques to achieve superior performance
25 over the prior art. The present invention provides a means for UPC replacement, while adding additional features and benefits, such as the elimination of manual (light-based) scanning, and greatly increased scanning (or item identification) speeds. The present invention further provides for simultaneous identification of numerous items, which is highly useful in many applications, such as inventory,
30 retail checkout, or the like.

The preferred embodiment of the present invention generally utilizes one-way communication (from the source device to the destination device) in order to simplify the circuitry on the source device; the source device does not require the use of a receiver.

5 The information communicated from the source device to the destination device typically takes the form of binary electronic product codes (“EPC”) or identification (“ID”) information, though it is not limited in any manner to these forms of information. Communicating other types of information, such as electronic telemetry (or any other type of measured or assigned data) is also
10 possible. In fact, any information that has a representation in a binary (or other) number format can be communicated with the present invention.

As illustrated in FIG. 1, the information is typically communicated from a set of source devices 110, 120, 130 to a single destination device 100; the preferred embodiment of the present invention utilizes simultaneous
15 communication of information from the set of source devices 110, 120, 130 to the destination device 100. Since the present invention has numerous applications, depending on the context of the example, some terms used throughout the discussion are interchangeable with other terms for ease of clarification. Thus, it should be noted that the following terms are used interchangeably throughout the
20 following discussion without loss of generality: source device, transponder, user, item, tag, or the like; it should also be noted that the following terms are used interchangeably throughout the following discussion without loss of generality: destination device, system controller, interrogator, reader, receiver, or the like.

The communication system employed by the present invention can
25 encompass several different forms of communication 140, including, but not limited to, optical communication, radio frequency (RF) communication, wired (contacted) communication, capacitively coupled communication, or inductively coupled communication. The preferred embodiment of the present invention utilizes a capacitively coupled communication link between the tags 110, 120, 130

and the reader 100, though other forms of communications links may be utilized without limitation.

The following detailed description of the present invention is divided into five major sections describing key aspects of the system and a final section providing examples of system operation. The preferred embodiment of the present invention utilizes all of the key techniques described below, though other embodiments may utilize only a subset of the described techniques.

I. Data Scrambling and Descrambling

As shown in FIG. 2, the data 200 that is communicated by the tag 110 to the reader 100 in the described system can take many forms, including, but not limited to, measured or other user defined data as described below. In the preferred embodiment of the present invention, the communicated data 200 consists of at least an identification data sequence. For example, the data 200 may consist of at least an EPC having 96-bits of identification data as outlined by David L. Brock in "The Electronic Product Code," MIT-Auto ID Center, January 2001. The EPC 200 serves to uniquely identify each tag (or item) 110 in the system, by reserving fields for a header 203, object class 204, vendor code 205, and serial number 206. Note, for example, that 96-bits of information provides for a huge number of unique IDs ($2^{96} \sim 8 \times 10^{28}$; as an indication of the enormity of this number, the mass of the earth is 6×10^{27} grams).

Additional information 202 is typically appended to the stored data 200 on the tag 110 in the preferred embodiment, such as user information, error checking or correction information (e.g., forward error correction (FEC), cyclic redundancy checks (CRCs), etc.), and other reserved bits. Note that the additional information (e.g., error detection or correction data) may be appended either before or after the data scrambling process described below, though it is desirable that if this additional information is appended after the data scrambling that it also has uniformly random properties.

Those skilled in the art recognize that several different additional forms of information (e.g., programmable timestamps, other user personal identification numbers (PINs), measured data, environment data, etc.) may also be predetermined and stored on the tags 110, 120, 130. Note that there are no
5 limitations placed on the amount or type of data stored on the tags 110, 120, 130 in the described system.

All of the tag functions are typically implemented in low complexity (i.e., low cost) circuitry. In order to keep the circuitry on the tag 110 simple, and to improve performance of the channel selection process in the system (as fully
10 described below), it is highly desirable to scramble the original ID data 200 prior to its being stored on the tag 110. This is typically accomplished through a randomization or scrambling process 211 that is carried out before the operation of storing data 230 on the tag 110.

This scrambling algorithm 211 is typically applied universally throughout
15 the system in order to assure that the EPC data 200, after being scrambled 220, exhibits desirable statistical (i.e., uniform and random) properties. Alternatively, in other embodiments, some other scrambling, encryption, or numbering assignment algorithm may be applied to the stored data 200 in order to effectively create the scrambled data 220. To gain additional information privacy, individual
20 vendors may optionally apply pre-encryption 210.

FIG. 3 illustrates an example of the system for embedding scrambled data 220 into the tag 110 in accordance with the preferred embodiment of the present invention. In FIG. 3, the original EPC 200 is obtained in the usual manner from the EPC manager 310, such as the manufacturer. The EPC 200 is then input into a
25 scrambler 330 that performs a scrambling algorithm and output the scrambled data (S_EPC) 220. A RF tag programmer/writer 350 then embeds the scrambled data, S_EPC, 220 into the tag 110. The scrambled data 220, which is a modified version of the original data 200, now resides inside the tag 110.

FIG. 4 illustrates a high-level block diagram for simultaneously reading
30 electronic identification data 200 from many RF tag devices 110, 120, 130. This

example illustrates how the tags associated with products residing on a shelf might be read during a typical inventory count. In operation, the reader 100 simultaneously activates a set of tags 110, 120, 130. The activated tags 110, 120, 130 then proceed with a multiple-pass transmission algorithm using the scrambled tag data 220 as a basis for channel selection (described in detail below in Section III).

For example, in a first pass of the multiple-pass algorithm, at least a portion of S_EPC1 (which is embedded in tag 110) is used to select Channel A 240, at least a portion of S_EPC2 is used to select Channel B 240, and at least a portion of S_EPC_n is used to select Channel C 240. It should be noted that channels A, B and C, or any combination thereof, can be the same or different. The reader 100 proceeds with its demodulation algorithm, and eventually obtains the S_EPCs 220 for the tags 110, 120, 130 on the shelf. The S_EPCs 220 are routed into a descrambler 460 that performs a descrambling algorithm to obtain the original EPC data 200 of the tags 11, 120, 130. The EPC data 200 corresponding to each tag can then be kept in the reader 100 or sent back to the original EPC manager 310 (e.g., the manufacturer) in the form of an inventory report. Those skilled in the art recognize that the descrambling operation may be performed at other locations, such as a remotely located computer or an on-line server. Collisions in the system of FIG. 4 are minimized because, instead of the highly structured EPC data 200, the tags 110, 120, 130 use at least a portion of the scrambled versions of the EPC data 220 to select a channel during each pass of the multiple-pass transmission algorithm. This scrambled data 220 very closely resembles uniformly distributed data, thus collisions between products with similar EPC data 200 are minimized. For more on multiple-pass transmission algorithms and channel selections, see Section III below; for more on collisions and collision resistance, see Section V below.

No information is exchanged between the tag 110 and the reader 100 before the tag 110 needs to select a channel to use for transmission (as described below). Thus, the scrambling and de-scrambling methods of the present invention

must be self-referential only; that is, the only information needed to scramble the EPC 200 or descramble the S_EPC 220 is the data itself.

The system described in the present invention calls for the use of a scrambling method that possesses certain key properties. An important property is that the scrambling method maps typical data sequences (such as EPC data sequences) to results that exhibit properties of a uniform random distribution. In the preferred embodiment, the scrambling method has two main properties:

1. Given two typical EPCs 200 represented with k -ary digits, where k is a predetermined integer (e.g., in a typical pair of EPCs 200 many, but not all, of the k -ary digits are the same), the probability that the scrambled S_EPCs 220 corresponding to these EPCs 200 match for n consecutive k -ary digits (used by the tag 110 to determine channel assignments) is approximately $1/k^n$; and
2. Given two typical EPCs 200 represented with k -ary digits, where k is a predetermined integer (e.g., in a typical pair of EPCs 200 many, but not all, of the k -ary digits are the same) whose scrambled outputs match for n consecutive k -ary digits (used by the tag 110 to determine channel assignments), the subsequent m k -ary digits (used by the tag 110 to determine subsequent channel assignments) will match with probability approximately $1/k^m$.

In the example of a binary represented EPC 200, these properties are related to a strong avalanche property whereby each output bit is dependent on every input bit and changing a single input bit, changes half of the output bits on average.

The present invention performs this scrambling and descrambling method by dividing and conquering the problem using the recursive strategies shown in FIG. 5. The scrambling algorithm 510 receives data and length information as input and recursively scrambles the left and right portions of the data. The descrambling algorithm 520 performs the inverse function to the scrambling

algorithm 510. The operations performed for all, except the base (last) level of recursion, are as follows:

For the scrambling method 510:

- 5 1. dividing a set of data into a first portion and a second portion;
2. performing a first scrambling method on the first portion of the set of data to create a scrambled first portion of the data;
3. modifying the second portion of the set of data with the scrambled first portion of the set of data to create a modified second portion of the set of data;
- 10 data;
4. performing a second scrambling method on the modified second portion of the set of data to create a scrambled second portion of the set of data; and
5. modifying the scrambled first portion of the set of data with the
- 15 scrambled second portion of the set of data.

For the descrambling method 520:

1. dividing a set of data into a first portion and a second portion;
2. modifying the first portion of the set of data with the second
- 20 portion of the set of data to create a modified first portion of the set of data;
3. performing a first descrambling method on the second portion of the set of data to create a descrambled second portion of the set of data;
4. modifying the descrambled second portion of the set of data with the modified first portion of the set of data to create a modified second portion of
- 25 the set of data; and
5. performing a second descrambling method on the modified first portion of the set of data.

In both the scrambling 510 and descrambling 520 methods above, the steps of modifying are invertible and selected from a group consisting of exclusive-or (XOR), modular addition, modular subtraction, or the like. Moreover, the first and second scrambling/ descrambling methods recursively execute steps 1 through 5, respectively, until the set of data to be scrambled/descrambled reaches a predetermined length, which means that a base case must be established. In the preferred embodiment, the predetermined length is one byte.

Once the set of data reaches the predetermined length, a predetermined function is performed. The predetermined function is invertible, and is preferably a lookup function; in the preferred embodiment, a substitution box (“S-box”) lookup function is performed. Stopping at a single byte is beneficial because scrambling/descrambling separate bits of data by the divide-and-conquer technique is significantly less efficient than simply using a lookup function. Stopping at larger sizes generally leads to large and unwieldy S-box tables.

The predetermined function in the present invention has a number of desired properties. First of all, the function should be invertible. The scrambling algorithm 510 uses the S-box lookup function, but the descrambling method 520 uses the inverse of the S-box lookup function; the function needs to be invertible, so that the original EPC 200 can be found. In practical terms, for a lookup function to be invertible, each entry will appear precisely once. In the present invention, the input to the S-box is one byte and the output is also one byte. The S-box and its inverse each contain 256 bytes of data.

A second property of the predetermined function is that it displays a strong avalanche criterion; that is, every output bit depends on every input bit. An additional property, called the Strict Avalanche Criteria (“SAC”), is that changing one input bit causes each output bit to change with exactly a fifty percent likelihood. This property is not strictly necessary for the present invention, although it would not be detrimental.

Finally, the predetermined function exhibits a low *dpmax*. The value for *dpmax* is the maximum of the entries in the XOR matrix of the lookup table. The (i, j) entry in the XOR matrix is the number of $0 < a < 256$ such that $f(a) \wedge f(a^i) = j$, where f is the lookup table. A low *dpmax* property provides for continued good mixing when repeated iterations of the table are used, which is basically the case in the present invention. Such lookup tables are often searched for in cryptography. A table satisfying all but the SAC is used in the advanced encryption standard (“AES”) cryptographic algorithm, for example, and would work well in the present invention. Reusing this table could save code space, if the AES was also used for other system functions unrelated to the use described in the present invention.

FIG. 6 illustrates a block diagram of the scrambling process unrolled into separate components. In the embodiment illustrated in FIG. 6, the input to the process is EPC data 200 that is 128-bit (or 16 bytes). This EPC data 200 is subdivided and labeled as separate bytes P_0 through P_{15} . The process of scrambling (or de-scrambling) starts on the top left side of FIG. 6, where the two leftmost bytes (P_{15} and P_{14}) are input to the “MixBytes” block 610. The “MixBytes” block 610 is composed of the S-box lookup functions 602 and 608, and labeled ‘S’, and the exclusive-or operations 606 and 604, and labeled ‘ \oplus ’. Following the block diagram down, the next step is to exclusive-or 624 the next two bytes (P_{13} and P_{12}) with the output of the “MixBytes” block 610. This algorithm proceeds by successively combining data using exclusive-or functions 622, 626, 628, 632, 634, 636, 642, 644, 646, 648, 652, 656, and 658 and mixing bytes using functions 620, 630, 640, 650, 660, 670, and 680 until, at the final stage, the output bytes 220 (C_0 through C_{15}) emerge. In accordance with the preferred embodiment, the entire process requires a total of sixteen S-box lookup operations and 64 one-byte exclusive-or operations.

In addition to the scrambling process described above, the data 200 may also be encrypted 210 prior to applying the universal scrambling algorithm (e.g., prior to programming the tag 110) to assure further data security. There are a

variety of known encryption algorithms (e.g., AES, Data Encryption Standard, International Data Encryption Algorithm, etc.) in the art that may be utilized for this task. The availability of this additional level of security is important for high-privacy applications (such as those where tags may contain sensitive medical or financial data).

II. Power-On Methods

A block diagram of a tag 110 in the spirit of the preferred embodiment is illustrated in FIG. 7. For a capacitively coupled system, the antenna 701 is a pair of conductive electrodes (e.g., capacitive plates), but in general can be any method of coupling energy from an electromagnetic field into a circuit. The alternating current (“AC”) power from the reader 100 that is coupled into the tag 110 is rectified in power converter 703, the direct current (“DC”) output of which is used to power the tag 110 and also serve as a tag energy monitor 704 which further enables communications (the elements of which will be discussed in more detail below). The state controller 705 acts on the tag data 220 and the communications channel selection block 240 to produce transmit information, which is applied to the transmission element 702 (such as a load modulation element that is well understood in the art) under the control of the channel modulator 708.

The data 220 stored on each tag 110 is typically stored in low complexity (i.e., low cost) circuitry, which then responds to inquiries from the reader 100. Each tag 110, 120, 130 typically waits for a first predetermined condition to be met before transmitting its information in a multiple pass algorithm, in accordance with the present invention. The first predetermined condition is typically set to be the same for each of the tags 110, 120, 130, though it could be randomly chosen or assigned in other embodiments. An example of a general flowchart showing tag transmission conditions is shown in FIG. 8. Note that in this flowchart, the second predetermined condition may be met by a variety of measures (e.g., when a first predetermined condition is no longer met or a second predetermined condition is met).

In the preferred embodiment, the reader 100 remotely powers the tags 110, 120, 130, and the first predetermined transmission condition is met when the instantaneous received power level at the tag 110 exceeds a predetermined threshold (that is generally determined by 703 and 704). FIG. 9 illustrates a flowchart of this action, where T1 and T2 represent a first and second power level threshold. Note that implementations employing other predetermined conditions (such as, particular synchronization pulses or pseudo-random pauses) can be employed by those skilled in the art without departing from the spirit of the present invention. Once the tag 110 receives power (either remotely from the reader 100 for a passive tag, or self-powered for an active tag), the tag 110 continuously monitors the received signal strength to determine when to begin transmitting. Once the tag 110 begins modulation and transmission of its data, it is fully activated. Note that multiple tags 110, 120, 130 will typically be fully activated at a given time in the preferred embodiment of the system.

The fully activated tags in a group will continue to transmit their information in multiple passes (fully described below) until a second predetermined transmission condition is met, at which time they will stop transmitting data. The second predetermined transmission condition in the preferred embodiment is met when the received power level at the tag 110, as observed by tag energy monitor 704, either falls below the first predetermined threshold or exceeds a second predetermined threshold, which is typically set higher than the first predetermined threshold.

In this manner, the first and second predetermined transmission conditions form a range of received power levels (e.g., a window) over which each group of tags is typically fully activated. In the preferred embodiment of the present invention, the power-on range is typically about 3dB wide, meaning that tags 110, 120, 130 will respond to power in a range of 1-2X (relative to some normalized received operational power level). Note that this powering window generally causes the tag's transmissions to fall within a proportionally narrow power window, which helps alleviate the typical near-far problem that affects some

communications systems (e.g., as in spread spectrum systems with non-orthogonal spreading codes).

All of the tags 110, 120, 130 in the system are typically assigned the same power-on range in the preferred embodiment, although other embodiments are possible, such as those that utilize programmable (e.g., pre-assigned, but likely different) or random power-on conditions. One such example may occur when different manufacturers are assigned different power-on range levels, providing some separation (or distinction) between different manufacturer's products.

In yet other embodiments of the described system, tags with two-way communication abilities may exist, in which case the first and second predetermined transmission conditions may consist of some type of synchronization pulses or other signaling information. In the case where the predetermined transmission conditions are random, they may be randomly determined on the tag 110, or during programming of the tag 110. Note once again that other implementations of these transmission controls (e.g., synchronization signals, two-way communication with the tag, etc.) are possible without departing from the spirit of the invention.

In an example embodiment illustrated in FIG. 10, the reader 100, which may be remotely controlled from a head office by controller 1001, is connected via a transmission medium 1003 to an antenna 1004 mounted on a shelf 1005. Objects 1020, 1021, 1022, of varying physical dimensions, have tags 110, 120, 130 located on different parts of the packages, and result in variations in coupling between the antenna 1004 associated with the reader 100 and the antenna 701 associated with the tags 110, 120, 130, further resulting in different received power levels by tag electronics 1012. Due to different coupling characteristics between the reader antenna 1004 and various tags 110, 120, 130 in the system, different tags may receive different power levels (demonstrated by the range boundary lines 1030 and 1031) for a given reader antenna excitation level (i.e., reader transmit power level). This effect also serves as a coarse population reduction of the tags present in the system in the preferred embodiment, since it is

likely that various tags 110, 120, 130 will begin transmitting at different reader transmit power levels and hence different times. Note, however, that multiple tags 110, 120, 130 will still typically begin transmission simultaneously for a particular power level in the preferred embodiment of the present invention. For example, there may be one thousand items (tags) in an inventory that need to be identified, and the reader 100 may step through ten different possible power levels, activating groups of roughly one hundred tags at each power level (though fewer tags will likely be activated at the extreme upper and lower power levels). In other embodiments of the invention, transmissions from multiple tags may only be synchronized (though not necessarily simultaneous), such as in the case of time-slotted (channelization) systems, where users choose a particular time slot (relative to a common reference) to transmit on. Note that in one embodiment, the reader 100 will step through all possible transmit power levels, starting with the lowest transmit power level. Thus, due to the particular power-on ranges of the tags 110, 120, 130, the reader 100 effectively controls when each group of tags begins and ends transmissions. This aspect is important since the reader 100 determines when all of the tags 110, 120, 130 in a particular power-on range (e.g., between 1030 and 1031) have been uniquely identified, at which time it can step to the next power level (e.g., above 1031) or terminate the identification process.

In another embodiment, the reader 100 may 'learn' or remember a range of expected power levels for a given inventory profile, and arrange its power sweep with priority given to those power levels with a history of activity. When the reader 100 steps to a power level where no tags are activated, it senses that condition (typically through a short energy or modulation detection measurement), and quickly steps to the next power level, so as to minimize the total reading time of the tags, as further described below.

III. Channel Selection and Transmission Methods

All multiple source (or multi-user) communications methods use some type of channelization method, as does the present invention. It is possible to

utilize any one of several channelization methods or techniques in the present invention. Generally, the channelization methods utilized by the present invention can be divided into two categories: orthogonal channelization methods or quasi-orthogonal channelization methods.

5 Orthogonal communications channels have the advantage that communication on a chosen channel does not interfere (at all) with communication on other channels in a linear system (i.e., the cross-correlation between different channels is defined as zero). Quasi-orthogonal channels are nearly orthogonal (e.g., having a cross-correlation value near zero for different
10 channels), and are typically utilized in direct-sequence code division multiple access (DS-CDMA) systems, where each user is typically assigned a different spreading code.

 It is well known in the art that different phases (i.e., time shifts) of a maximal length linear feedback shift register ("LFSR") sequence (i.e., an m-
15 sequence) are known to have low (i.e., quasi-orthogonal) cross-correlation properties. The cross correlation value of two unaligned sequences is defined to be $-1/N$ (normalized), where N is the length of the LFSR pseudonoise ("PN") sequence. Different code phases of the same base m-sequence are often used to channelize different users in a code-division multiple access system. Each symbol
20 or bit in the PN sequence is typically referred to as a 'chip', as is well known in the art.

 Some examples of orthogonal channelizing functions include, but are not limited to, Walsh functions, timeslots in a slotted system, frequencies in a frequency division system, specially augmented PN codes, etc. Some examples of
25 quasi-orthogonal channelizing functions include m-sequences or PN sequences as described above.

 An example of a specially augmented PN code is one that has an artificially inserted (i.e., not generated by the normal operation of the LFSR) binary zero into the sequence (at different points in the sequence depending on the
30 code phase), such that the time-aligned (i.e., synchronized) artificially inserted

zero occurs at the same time offset on the channel, resulting in a zero cross-correlation value between different code phases of the same m-sequence. Note that the preferred embodiment of the present invention utilizes these specially augmented m-sequences (whose generation is shown in FIG. 11) to obtain
5 orthogonal code channels in the synchronized system. As an added benefit of the employed spread spectrum techniques, resistance to interference (also called processing or spreading gain) is also achieved, as is well known in the art of communications. The application of such techniques is important for harsh electromagnetic environments, such as factory settings.

10 As referenced above, the tags 110, 120, 130 in the described system transmit their data using a multiple pass transmission algorithm. The multiple pass transmission algorithm is critical in determining the total reading time of the tags 110, 120, 130, and consists of several different aspects. The general idea employed in the algorithm is that each tag 110, 120, 130 will choose a particular
15 (preferably a uniform random) channel for communications in each algorithm pass.

In the preferred embodiment of the described system, the channel selection 240 is typically based directly on the data 220 stored on the tag 110. The tag 110 will then typically transmit its information (i.e., identification data) in the
20 preferred embodiment on the chosen channel, until the next pass of the algorithm, at which time it will choose a new channel and repeat the process. The transmissions of the tags are assumed to be roughly synchronized (by virtue of the first predetermined condition) in the preferred embodiment of the present invention.

25 The channel selections by each of the tags are based upon predetermined information (i.e., determined either at tag programming 230 in typical embodiments, or possibly in the design of the tag itself). In the preferred embodiment of the present invention, the channel selections of each tag 110 are determined (in an algorithmic manner) directly from the identification data 220
30 that is stored on the tag 110 (as further described below). Also note that in other

embodiments, the predetermined information above can include randomly generated numbers not directly based on the data stored on the tag 110.

As fully described in Section I above, and a key for good system performance, the preferred embodiment of the present invention requires that at least a portion of the data 200 (e.g., EPC, CRC, etc.) be pre-randomized (or scrambled) 211 before storing it 230 on the tag 110. Since the tag 110 essentially uses the stored data 220, or a portion thereof (e.g., 221, 222) to select 240 a communications channel in each pass of the multiple pass algorithm, it is crucial that the data 220 appear to be uniformly random for the best overall system performance. This is accomplished through a low complexity reversible scrambling algorithm 211 that is fully described in Section I above.

In particular, as illustrated in FIG. 12, the channel selection process 240 in each of the multiple transmission passes in the preferred embodiment is carried out by utilizing a predetermined subset (e.g., 221, 222, 223, 224) of the pre-scrambled (i.e., randomized and stored) data 220 to select the communications channel 240 in each pass. A channel selector 1220, such as a commutator or multiplexing device 1240, typically selects a channel. A new subset 221, 222, 223, 224 (i.e., a new random number draw) of the data stored on the tag 220 is typically utilized for channel selection in each subsequent pass of the algorithm, ensuring a random and independent selection of channels throughout the multiple pass transmission algorithm.

Note that the tag 110 may transmit all of its data 220 in each algorithm pass (as in the preferred embodiment), or only a portion of the data (i.e., generally enough data is transmitted to determine the channel utilized by the tag in the next pass). Typically, the portions 221, 222, 223, 224 of the data that are utilized for the channel selection in each pass of the algorithm are unique and contiguous sections of the data 220, preferably pre-randomized. A particular selection of channels for passes of the multiple pass transmission algorithm is termed a 'channel selection profile'.

For example, in a system with 128-bits of pre-scrambled identification data 220 stored on each tag, unique but sequential sections of 8-bits may be utilized to choose one of 256 (i.e., 2^8) channels in each of 16 (i.e., 128/8) algorithm passes. Thus, the first randomized byte of data (e.g., 221) for each tag chooses 240 the communications channel for each tag, respectively, on the first pass of the algorithm, the second (and hopefully different) byte (e.g., 222) of randomized data for each tag is used to choose 240 the channel for transmission on the second pass of the algorithm, and so on. This multiple transmission pass process continues until all of the data stored on the tag is exhausted (e.g., the 16th pass is completed in this example; in FIG. 2, this would correspond to 224), or the reader 100 signals the tags to stop transmitting (generally sensed in the tag 110 by the second predetermined condition being met in 704 (1210) as described above). Once the data is exhausted, the whole process may optionally be repeated, though the tags will typically choose the same (deterministic) channels. Note once again it is desirable to choose a random and uniquely determined channel for each algorithm pass for each tag in order to randomize the collisions that will inevitably occur (see further details in Section V below).

Of course, those skilled in the art recognize that other (e.g., non-contiguous or not completely unique) sections of the data may be used to either directly or indirectly select the communications channel in each pass. In this manner, it is possible to extend the maximum number of algorithm passes before the channel choices repeat, virtually without limit. The channel selection profile (or channel choice algorithm) may be modified after some number of transmission passes, such that a different subset of the same data 220 is utilized for later channel selections 1220 (in order to extend the unique channel choices before any repetition of the pattern occurs). For instance, after 16 passes of the multiple pass transmission algorithm, the tags may shift the channel selection data (i.e. the predetermined data) by 4-bits (in the above example) to arrive at new channel selections for subsequent passes of the algorithm. In this manner, it is possible to

extend the number of unique channel choices practically without limit, though the tag circuitry complexity is increased.

Yet other embodiments of the channel selection algorithm may also apply some type of mapping (generally one-to-one look-up table, or other algebraic or logic) function to determine the channel choices from the (generally limited) data stored or programmed on the tag. The only key characteristic of the channel selection process is that the channel choice be computable in the reader once some portion of information is known about the data in the tag.

Since the channel resources are limited (i.e., there are a limited number of available channels for each user to select in each pass of the multiple pass communications algorithm), there will inevitably be collisions among the transmitting tags. A collision is defined as the case where two or more tags choose to communicate on the same channel during a particular algorithm pass. This situation is to be expected under normal system operation. For example, for a typical case of twenty-five tags communicating over 64 channels, the probability that there is at least one collision is 99.6% per pass. This is based on the fact that, for M tags communicating over N channels, the expression for the probability of no collisions is

$$\Pr\{\text{no collision}\} = \frac{N!}{(N-M)!} \cdot \frac{1}{N^M}$$

Several numerical examples of colliding tag transmissions and their remedies are discussed below in Section V - Collision Mitigation Methods.

In many cases, the number of tags present in the system (at a particular power-on level) may even exceed the number of available channels (especially on earlier passes of the preferred embodiment algorithm, or when the number of available channels is set low as described below). This situation is completely acceptable in the present invention when orthogonal channelization means are utilized. Note that typical DS-CDMA systems (using quasi-orthogonal channelization codes) would be considered overloaded at that point, and no reliable communication could take place (especially without further knowledge of

the tags' transmission characteristics). Importantly, in the described system, the activated tag population can effectively be further reduced by collision mitigation techniques, which are fully described in Section V below.

Also importantly, the preferred embodiment of the present invention
5 utilizes a variable number of channels per pass (generally determined by 221, 222, ... 224) of the multiple pass transmission algorithm in order to improve overall system performance (e.g., total reading time, total system capacity, reliability, etc.). In other words, the number of available channels in one pass of the multiple pass transmission algorithm could be different from the number of channels
10 available in another pass of the transmission algorithm. The variable number of channels per algorithm pass (i.e., per unit time) is also termed a dynamic channel profile in the present discussion, since the number of available channels changes dynamically with time. Implementing the dynamic channel profile essentially optimizes the total transmission time (or total reading time) for an expected tag
15 population.

Note that the transmission time for each pass of the algorithm is typically proportional to the number of channels available for that pass of the algorithm (regardless of the channelization method that is utilized). The total transmission time (T_{TX}) for the multiple pass transmission algorithm can be expressed as

$$20 \quad T_{TX} = \frac{1}{R} \sum_{i=1}^L N_i * B_i$$

where L is the number of transmission passes that are required to successfully transmit the data, R is the transmission (signaling or channel symbol) rate, B_i is the number of data symbols that are transmitted per pass, and N_i is the number of channels available (or spreading gain) in the i^{th} pass of the algorithm. Note that in
25 the preferred embodiment of the present invention, L can be as high as 16 passes, B_i is fixed at 128 bits, R is equal to 62.5KHz, and the particular N_i values are given in the example above, though this is only one particular embodiment of the system. Recall that the number of channels available per pass (N_i) generally

depends on the number of bits utilized to select a communications channel in each pass (n_i) as follows (as also shown in 240):

$$N_i = 2^{n_i}$$

In the preferred embodiment of the system, N_i represents the spreading gain and number of available code phases per pass, and R is the signaling rate in chips per second. Note that the application of advanced collision mitigation techniques (described in Section V below) can greatly reduce the required number (L) of transmission passes from the tags 110, 120, 130. In general, there are no restrictions on any of the values in the above equation in other embodiments of the described system.

Since the transmission time per pass is dependent on the number of available channels per pass (and the symbol rate) in the preferred embodiment as shown above, the system's total reading (i.e., acquisition) time performance can be improved for a small number of tags by using a smaller number of channels in earlier passes of the multiple pass transmission algorithm (since adding more channels to the system in such a case would be of little additional benefit for small numbers of tags). The number of channels may be increased in later passes of the algorithm (potentially in multiple steps) to accommodate cases where larger numbers of tags are present in the system, and the reader 100 does not employ the more sophisticated signal processing (e.g., advanced collision mitigation) techniques referenced in Section V below.

In this manner, systems with a small number of tags present would typically not be penalized by the longer transmission time of systems with a larger number of (earlier) channel choices, while at the same time systems with a larger number of tags present would also not be significantly penalized (since earlier passes of the multiple pass algorithm also typically take a much shorter time due to the smaller number of channels available initially). Also, increasing the number of channel choices in later algorithm passes ensures that systems with a large number of tags present will successfully acquire all of the data in a limited number of algorithm passes (thus increasing system reliability).

For example, the preferred embodiment of the present invention utilizes 128-bits of data 220, with 32 channels in the 1st and 2nd algorithm passes, 64 channels in the 3rd through 6th algorithm passes, 128 channels in the 7th and 8th passes, and 1024 channels in the remaining 8 algorithm passes. Note once again that unique subsets of the data 220 are utilized to directly choose 1220 the communications channel 1260 in each pass in this embodiment, resulting once again in a maximum of 16 algorithm passes before unique, non-overlapping portions of the data are exhausted. Other embodiments of the present invention may utilize a variable number of channels per transmission algorithm pass that changes after a predetermined number of passes. For instance, the first sixteen passes of the multiple pass transmission algorithm in the above example may utilize anywhere from 32 - 256 available channels (i.e., five to eight-bits of channel selection data), while the next sixteen passes may utilize anywhere from 256 - 4096 available channels (i.e., eight to twelve-bits of channel selection data). In this manner, the dynamic channel profile (or number of available channels per algorithm pass) may be extended virtually without limit. Also note once again that the maximum number of passes may be extended by utilizing overlapping or interleaved portions of the data to drive the channel selection algorithm.

The actual choice of the number of available channels per algorithm pass (also called a dynamic channel profile) in a particular embodiment of the system may also depend (in addition to the expected number of tags present in the system) on the expected or predominant type of signal processing algorithms (such as the type of collision mitigation algorithms) utilized in the reader 100. Note that the variable number of channels per algorithm pass may also result in channel profiles that decrease in later passes. In general, any channel profile that changes versus time is considered to be a dynamic channel profile for the purposes of the present invention.

Note that the channel profile of a particular tag 110 does not necessarily have to be known by the reader 100 *a priori*, but that is generally the case. If the channel profile of a tag 110 is not known, the reader 100 would have to ascertain

the period of the PN (chipping) sequence for example (possibly through measuring its autocorrelation or spectral properties), and act (demodulate) accordingly.

Specifically, in the preferred embodiment of the present invention, the random channel choices are utilized to select a particular spreading code (or code channel in 1220) in each pass of the multiple pass transmission algorithm. More specifically, in the preferred embodiment, portions of the data 220 stored/programmed on the tag 110 are used to directly specify a time offset (or code phase as in 1220) of a length-N specially augmented m-sequence (where N is equal to the number of channels in a particular algorithm pass, as described above). This process is shown schematically in FIG. 11. Different phases of a PN sequence are commonly obtained by applying a masking function (or AND-XOR reduction network 1100) of the PN generator (LFSR) state, which effectively performs a modulo-2 sum of two or more m-sequences to produce a third code phase of the same m-sequence. Thus, all of the tags 110, 120, 130 use the same basic LFSR (m-sequence) generator in each algorithm pass, beginning with the same initial generator state in the preferred embodiment, such that all of the tags 110, 120, 130 transmissions are synchronized to a known basic initial generator state. These aspects are key to quick and effective demodulation in the reader 100, as described in Section IV below. Note that the basic LFSR sequence generator length (i.e., primitive polynomial) typically changes dynamically (changing the number of channels) per algorithm pass, as described above.

The traditional m-sequence generators are typically made to be specially augmented PN sequence generators by forcing a zero output for the first chip (or PN bit) time in the preferred embodiment, ensuring that the cross-correlations of the sequences from different tags will be zero over a given sequence period. Note that forcing a zero into the code sequence at other points in time would also produce orthogonal sequences (as is done in other systems), and that other types of orthogonal function generators could be used in the place of the LFSR PN generators (e.g., Walsh or Hadamard functions) in other embodiments. The data

220 stored on the tag 110 is then spread by the generated spreading codes 1260 by traditional means 1230 (e.g., an XOR gate in digital implementations, or a multiplier in analog implementations, as is well known to those skilled in the art). The spread data signals of the activated tags are then sent (in aggregate) over the given communications channel.

Note that the tags could employ a range of modulation types to transmit their data (e.g., amplitude modulation, phase modulation, frequency modulation, or some combination thereof). The preferred embodiment of the present invention utilizes a form of amplitude shift keying ("ASK") from load modulation via transmission element 702, though other modulation types and implementations are certainly possible (e.g., Differential Quadrature Phase Shift Keying, Quadrature Amplitude Modulation, Pulse Code Modulation, Pulse Amplitude Modulation, Pulse Position Modulation, etc.). The employment of a variety of data encoding and mapping techniques is also possible with the present invention. Some examples of encoding techniques include, but are not limited to, return to zero (RZ), non-return to zero (NRZ), Manchester, and differential encoding, which are all well known in the art. Note that it is possible to use many different encoding, modulation, coding and signaling types in the present invention without loss of generality, as is known to those skilled in the art. Some examples of coding techniques include CRC codes, convolutional codes, block codes, etc., which are also all well known in the art.

The tags 110, 120, 130 in the preferred embodiment also directly modulate the carrier supplied by the reader 100 via transmission element 702; thus, they have no local oscillator (though the use of a locally generated carrier is certainly possible within the scope of the present invention, and does not in any way limit its application). In the preferred embodiment of the present invention, power converter 703 rectifies the carrier signal from the reader 100 so that the reader 100 remotely powers the circuitry on the tag 110. Note that the use of actively powered tags is also possible and does not in any way limit the use of the present invention. A general goal of the present invention is to minimize the complexity

of the tag 110, and through the use of the described techniques in the preferred embodiment, the circuitry on the tag 110 can be kept to a minimum.

IV. Fast Demodulation Methods

5 As shown in FIG. 13, the reader 100 typically begins the reading process of the tags 110, 120, 130 by initializing the output of a signal source 1310 with a transmit level control 1320 and amplifier 1330, and transmitting power at some minimum level. The reader 100 then begins transmitting a continuous wave at that level in the preferred embodiment. Once the reader 100 is transmitting at a particular power level, it typically listens (via the coupling device 1340 and
10 antenna 1345) for any return signal from the tags 110, 120, 130. This activity detection may take the form of a modulation or energy detection measurement, such as detecting signal levels or signal swings in each of the possible communications channels (which is further described below). It is desirable to make this measurement period as short as possible, so if no tags are activated at a
15 particular power level, the reader 100 can rapidly step (generally in an increasing manner) to the next power level. If signals are sensed at a particular transmit power level, the reader 100 may begin the full demodulation processing 1390 (possibly employing collision mitigation techniques, as discussed in Section V
20 below). Note that the reader 100 may also send out modulated carrier signals, synchronization pulses, or asymmetric carrier waveforms in other embodiments of the system without loss of generality.

 The signal processing performed by the reader 100 can be performed in either hardware or software architectures, or some combination thereof. Typical
25 embodiments will include some selectivity 1365, amplification 1370, analog-to-digital conversion 1375, and DC acquisition and gain control functions 1380. In general, the reader 100 cycles through each of the possible communications channels (either sequentially or concurrently) in a given communications pass, and looks for signal energy on each. Those skilled in the art recognize that there
30 are many methods available to detect the presence of a signal, and to detect the

presence or absence of collisions, which may vary based on the modulation and signaling type. In general, the reader 100 may also perform active or passive suppression 1360 of its carrier signal in certain embodiments, and interference or noise cancellation (for any form of interference from sources other than the desired tags in the system).

As stated above, the preferred embodiment of the present invention utilizes spread spectrum modulation in the tags 110, 120, 130. Thus, the received data must be despread in the reader 100 for each code channel by first applying each possible spreading code, as is well known in the art.

More specifically, because the preferred embodiment of the present invention utilizes specially augmented m-sequences as spreading sequences in the tag 110, very fast, efficient and novel demodulation (i.e., despreading and channelization) techniques can be utilized in the reader demodulation processing 1390. These techniques substantially reduce (e.g., by about a factor of 57 in the preferred embodiment) the processing power required in the reader demodulation processing 1390, which results in faster reading times and lower cost implementations of the reader 100. The actual processing savings will depend on the number of channels employed in each pass of the multiple pass system, and can be expressed in terms of a factor (F) which is equal to the ratio of the number of traditional despreading operations to the number of improved despreading operations per symbol (using a novel combination of received sequence re-ordering and Fast Hadamard Transforms (FHTs)):

$$F = \frac{1}{L} \sum_{i=1}^L \frac{(N_i)^2}{N_i * \log N_i} = \frac{1}{L} \sum_{l_{passes}} \frac{N_i}{\log N_i},$$

where L is equal to the number of passes required to successfully demodulate the source data, and N_i is (once again) equal to the number of channels in the i^{th} pass. This factor directly represents a processing savings (which is typically expressed in terms of millions of operations per second (MOPS) or millions of instruction per second (MIPS)) in the reader demodulation processing 1390. Thus, in this example, a processor 1390 that is fifty-seven times less capable (e.g., 10 MOPS

vs. 570 MOPS) may be utilized in the reader 100 in the preferred embodiment in the best case (with no collision mitigation as described below).

Recall that specially augmented m-sequences (shown in box 1120 of FIG. 11) are an orthogonal extension of traditional PN sequences, which have some similarities to orthogonal Walsh codes (shown in box 1420 of FIG. 14); namely, the two sets of sequences have the same number of binary ones and zeroes in the sequence. In fact, the two types of sequences (i.e., specially augmented m-sequences and Walsh sequences) are related through the use of a single special re-ordering function. This special re-ordering function is derived directly from the primitive polynomial that is used to generate the base m-sequence (as is shown in the tag sequence generator 1110) in reader receiver block 1520 of FIG. 15. The sequence re-ordering function 1510 is used to directly re-order the data samples (or elements) as the receiving device 1375 receives them. The receiving device 1375 could be an analog to digital converter, an analog sample and hold device, a register, or any other device that receives a signal. Note that a single sequence re-ordering 1510 function is applied to the composite received signal, which consists of transmissions from several different tags 110, 120, 130 using multiple code channels (or code phases as in 110).

Once the received sequence has been re-ordered in a storage medium, such as a memory buffer 1530, it resembles a sequence from a set of valid Walsh sequences, and fast transform techniques, such as a Fast Hadamard Transform (FHT), may be utilized to rapidly (and concurrently) despread the data from the tag 110 for all data channels (as shown in 1540). FHTs are used to rapidly correlate data sequences against a complete set of Walsh codes (in parallel), as is well known in the art. Any transform related to FHTs (e.g., Fast Walsh Transforms, Walsh-Hadamard Transforms, recursive Walsh transforms, etc.) may be utilized with the described fast correlation methods without departing from the spirit of the present invention. Also note that all of the described processing techniques can be performed in either the analog or digital signal processing domain.

Note that traditional FHT algorithms (e.g., as shown in box 1410) are well documented, and their basic kernel operation (box 1400, termed a 'butterfly') is shown in FIG. 14. A radix-2 FHT butterfly is similar to a radix-2 FFT butterfly, though it consists of multiplying the data elements by only a +1 and -1 value (or equivalently adding and subtracting the data values together). The trellis structure 1410 of an 8x8 FHT is also shown. Each output of an FHT 1550 is termed an FHT bin or FHT code channel. Since the FHT is a fast transform, it can be shown that the processing savings over traditional correlation (similar to the factor F expressed above) is equal to $(N^2 / N \log N)$ for an N-point orthogonal sequence. This same savings is realized by utilizing the described fast correlation techniques.

The exact received data re-ordering function 1520 is determined by observing the states that the tag Fibonacci LFSR (as shown in 1110) cycles through during normal operation (also refer to the example below). The states that the LFSR progresses through correspond directly to the indirect addresses that the incoming (spread) received data samples must be stored at in the received data memory buffer (1530 or other storage medium) as they are received (linearly) in time. This sequence of addresses (in 1520) may alternately be stored in a storage medium (e.g., Random Access Memory, Read Only Memory, Hard Disk Drive, etc.) instead of being actively generated in the receiver. In this manner, the elements of the received m-sequences (or sums of m-sequences) are re-ordered such that they now represent exactly the elements in Walsh sequences (or more specifically, the rows in a Hadamard matrix). Thus, a traditional fast (Hadamard) transform (correlation) method may now be utilized (in 1540) to despread the received data channels in parallel. Note that the data sequences can also be double buffered in memory to accommodate any processing latency.

The output indexes (or bins) 1550 of the FHT that exhibit signal energy correspond directly to the mask values 1130 (when expressed in binary) that were used in the AND-XOR reduction 1100 in the tags 110, 120, 130. For example, the channel selection code 1130 (the 'c0-c4' shown in FIG. 11) (transmitter

processing) directly corresponds to the active outputs 1550 of the FHT block 1540 in FIG. 15 (receiver processing). Recall that the binary mask value 1130 is applied in the tag 110 to select a particular code channel (or code phase). This is also shown in FIG. 7, where the mask 710 is drawn from the tag data 240 to input to the channel selection 240. That is, the binary mask value 1130 (and FHT bin index) directly corresponds to the data 221, 222, 223, 224 stored on the tag 110, that was utilized to select a channel during a particular pass (see also identifiers 1710, 1820, 1830 and 1840 in FIG. 17 and FIG. 18 for a supplementary demonstration of how tag data relates to the channel choice). Each tag 110 will send its data 220 over a fixed channel 1260 for the duration of each of the passes of the multiple pass algorithm in the preferred embodiment. The output signal level at each FHT bin corresponds directly to the signal level on each code channel 1260 (e.g., for each code phase) after despreading. As further discussed below, the data signal 1550 at the output of each active FHT bin during the channel selection portion of the received data sequence can be verified by matching it up with the binary FHT index value (since the two sequences should match for valid data). This technique is shown in FIG. 18 for Pass #2 of the multiple pass transmission algorithm. Note that the data sequence 1820, 1830, 1840 over the portion 222 used to select the channel 240 for the second pass is the binary equivalent of the FHT bin number.

Through the combined re-ordering and FHT technique shown in FIG. 15, the demodulator is able to rapidly demodulate (i.e., despread) all possible code channels (i.e., code phases) in the preferred embodiment. Note that a N-point FHT will typically be required to demodulate N-channels for each received symbol period in the receiver (which corresponds to the required dechannelizing and despreading operation for each potential data channel and symbol). Also note that other embodiments of the transponder system may utilize orthogonal Walsh codes for channelizing functions, in which case the FHT bins would correspond directly to the Walsh code channel indexes (and no re-ordering process is necessary). Such a system would not have as good of interference rejection

capabilities when compared to the preferred embodiment though, since Walsh channelizing codes are periodic and could be highly correlated with periodic interference sources. Therefore, the preferred embodiment of the system utilizes specially augmented m-sequences as channelizing functions, and the above
5 described demodulation techniques.

As an example, for a system that utilizes length 16 ($N=16$, $n=4$) specially augmented PN sequences in the tag transmitters, the sequence 1260 represented by the channel selection value 1130 (n_i) of '0001' (1) in binary will be '0111101011001000', while the sequence 1260 represented by the channel
10 selection (mask) 1130 value of '1001' (9) in binary will be '0010110010001111' (which is just a different time shift or code phase of the same basic m-sequence that is subsequently specially augmented with a leading zero). An example of the tag PN generation and mask circuitry for a primitive polynomial of 23 (when expressed in standard octal notation) is shown in FIG. 11. Two tag transmitters
15 are assumed to send these sequences independently over the communications channel. The reader receiver will resolve these two signals using a special re-ordering function 1520 and FHT processing (as shown in FIG. 15). The special received data sample re-ordering that must be utilized for the transmitted PN sequence is {0,15,7,11,5,10,13,6,3,9,4,2,1,8,12,14, the same as is shown in 1120}
20 for this example. This sequence may be generated in the reader 100 by replicating the m-sequence generator 1110 that is utilized in the tag 110, and observing the PN generator states, or by simply storing the required re-ordering sequence in memory. The re-ordering sequence is utilized to store the incoming received data sample stream into memory using indirect addressing. For example, the first valid
25 A/D sample that arrives at the reader is stored in memory buffer location 0 of storage medium 1530 (as is the case for all specially augmented codes), the second sample is stored at memory location 15, the third at location 7, and so on. Once N (16 in this example) samples are received, normal FHT processing 1540 can be performed on the newly re-ordered data samples in the memory buffer
30 1530. The re-ordering function will translate the '0001' PN code above into the

sequence '0101010101010101' (which is identical to Walsh code 1) and the '1001' PN code into the sequence '0101010110101010' (which is identical to Walsh code 9). The FHT 1540 will indicate that signal energy is present (e.g., tags are transmitting) in bin 1 (corresponding to channel code 1) and bin 9 (corresponding to channel code 9) of output 1550. Thus, by observing the bin 1 and bin 9 FHT outputs for each transmitted symbol, the remainder of the tag data can be sensed.

Note that the techniques described above may be utilized for traditional (i.e., non-specially augmented) m-sequences by assuming in the receiver that the first chip (or symbol) that is sent by the tag 110 is a binary zero (which is equivalent to a +1 normalized signal value on the channel), even though no such signal was actually sent. Thus, the first buffer location in the storage medium 1530 is initialized to a +1 value, and processing (i.e., re-ordering 1510 and FHTs 1540) continues as normal. In this manner, very fast correlation can be performed for multiple code channels (or code phases) for traditional PN sequences. Other normally augmented PN sequences can also be accommodated by keeping track of where the additional chip (e.g., other than the first chip as described above) is inserted into the sequence.

The above described fast correlation techniques (i.e., a particular receive sequence re-ordering 1510 and FHT 1540) apply to any communication system that uses PN sequences that can be generated with an AND-XOR reduction network 1100 (whether or not they are generated with such a network). Many popular communications systems utilize these types of PN sequences, or sequences generated from a combination of traditional m-sequences (such as Gold codes, as is well known in the art). Some examples of such systems are the IS-95, IS-2000, 3GPP CDMA cellular systems, and the GPS CDMA location system. The above fast correlation techniques can be equally as effective in these systems.

In any case (regardless of the channelization techniques employed), the composite received signal must be filtered and amplified in the receiver front end 1610, and then channelized (or de-channelized) 1620 in the reader 100 as illustrated on FIG. 16. Each channel is then generally processed separately

(though possibly concurrently) for signal and collision detection purposes (generally in 1630). For example, in another embodiment of the system that uses Walsh codes in place of the described m-sequences, an FHT operation could still be utilized to simultaneously demodulate all of the different data channels as described above. Other embodiments of the system may utilize a bank of (parallel or time-shared) traditional despreaders (in place of 1540, 1620) to perform the dechannelization and despreading process. A despreader typically consists of a multiplier followed by an integrate and dump function, as is well known in the art.

In another example of the communication system, other embodiments may utilize orthogonal timeslots as the channel (such as in a slotted ALOHA system), in which case signals from different tags would be demodulated as they arrive (at different points in time). It should be noted that the selected channelization method does not change the general type of collision mitigation algorithms that can be employed in the reader 100, as further described below.

Also note that the demodulation process is generally a multiple iteration process in many embodiments of the present invention, since it is typically not likely that all tags will successfully transmit their information on the first pass of the multiple pass transmission algorithm. Thus, the reader 100 must remain powered up (at the same power level) and continually demodulate the incoming data until all data from the tags has been successfully received (further using the methods described below). Also, when advanced collision mitigation techniques 1630 are utilized in the reader 100 (as detailed below), multiple demodulation iterations (e.g., FHTs) may be required for each pass of the multiple pass algorithm. Also note that subsequent passes of the multiple pass transmission algorithm may require the demodulator to adapt to a new number of channels, as described in the dynamic channel profile discussion above.

V. Collision Mitigation Methods

As referenced above, there are a limited number of communications channels in this (and any) communications system for which the tags 110, 120,

130 can utilize to communicate to the reader 100. Since there are a limited number of communications channels, and no organized assignment of channels among multiple tags (i.e., random assignments are effectively utilized), there will inevitably be collisions of transmissions from the tags in the described system. A
5 collision is defined as the case or event when two or more tags choose to communicate on the same channel at the same time (i.e., during a particular pass of the multiple pass transmission algorithm). It should be noted that the assignments are effectively random because the data stored on the tags closely approximates uniform random data, as indicated in Section I of this document.

10 It is possible to either utilize or not utilize collision mitigation techniques in the reader 100 in the described system (as further detailed below), depending on the desired complexity of the reader 100. For instance, a low cost receiver may not utilize any collision mitigation techniques, while a higher cost (higher processing power version) of the receiver may utilize advanced collision
15 mitigation techniques.

The general discussion below first assumes that no particular collision mitigation techniques are utilized, and then later examines cases where collision mitigation techniques are utilized. Note that the tags 110, 120, 130 in general transmit the same patterns regardless of whether collision mitigation is utilized in
20 the reader 100. Each tag (e.g., 110) is in effect 'blind' to other tags present in the system (e.g., 120, 130). Performing the following additional steps further carries out the demodulation process in the receiver.

Specifically, in the preferred embodiment, the presence of a low deviation ASK signal(s) from a tag is typically detected by subtracting out any mean signal
25 level (i.e., dc value as in 1380) from a channel to obtain a normalized signal, and examining the absolute value of the remaining (normalized) signal. Note that a form of automatic gain control (also in 1380) may also be applied to further normalize the signal levels. If the absolute value of the normalized signal level exceeds some threshold (generally over some period of time), a signal is said to be
30 present on that channel in the preferred embodiment.

Once a signal is detected on a particular channel, the reader 100 must typically detect if a collision has occurred on that channel. This may typically be achieved by examining the variance of the absolute value of the normalized signal level over some time period. If the variance of the absolute value of the signal exceeds some (different) threshold, a collision is said to have occurred on that particular channel (due to conflicting binary data values of different tag's ID data – see FIG. 17); otherwise, a single signal is said to be present on that channel (as in FIG. 18). Once again, those skilled in the art recognize that filtering or averaging of these measurements and indicators may be utilized to increase their reliability (e.g., to increase the SNR of the estimates). Thus, the longer the time period that is observed for such measurements (and utilized in the subsequent filtering), the more accurate and more reliable the estimates will become. Collisions may also be detected by alternate means, such as standard error detection (e.g., CRC) means, though these methods may not in all cases properly detect collisions. Also note that whether or not collisions occur on a channel, standard error correction means can be employed to correct for transmission errors and improve the accuracy of the signal estimates. These measurements are typically performed on all of the available (possible) communications channels in a given pass (which may vary with the pass number of the multiple pass algorithm, as described above).

Thus, the reader 100 typically characterizes whether any signal is present on (each and) all of the possible communications channels per pass, and whether a collision has occurred on each channel where signal(s) are present. Recall that a collision is generally defined as when two or more tags utilize the same communications channel during the same pass of the multiple pass algorithm. When a collision occurs on a given channel, the data for that channel is generally lost if no collision mitigation techniques are utilized. If a signal is present on a given channel, and no collisions are detected, the particular signal on that (given) channel is typically said to be successfully received, and the reader 100 generally knows the entire data sequence of that particular tag.

Note that some embodiments may also perform error detection or correction (or some other type of signal integrity measure) to ensure that the data is valid and received correctly. Also note that if the tag channel selection data is transmitted, the reader 100 may also check that the tag 110 has indeed
5 communicated on the expected communications channel (serving as another form of error checking for the portion of the data that is used to determine the channel as described above – also see FIG. 18, where the channel selection data 222 for the second pass must match up with the channel choice, as identified with 1820, 1830, 1840).

10 Once the signal from the tag 110 is known (and possibly confirmed), it may be ignored, or removed (as described below) from the rest of the signal population. A form of collision mitigation is implemented if a signal from a particular tag is effectively removed from the signal population (through a variety of possible algorithms). Note that the removal of the signal does not have to be
15 exact to realize a benefit from collision mitigation.

FIG. 19 shows a general flow chart for reader actions when utilizing collision mitigation techniques. In this case, the reader 100 will attempt to resolve as many collisions (e.g., errors in data) as possible before moving on to the next pass of the multiple pass transmission algorithm (e.g., by holding the reader
20 transmit power constant in the preferred embodiment).

As described above, the reader 100 will generally keep transmitting at a given power level until some confidence level (or probability) is obtained that all actively transmitting tags have been identified.

If the signal is not actively removed (or subtracted) from the signal
25 population (or composite received signal), then no collision mitigation is said to have occurred. In that case, it is possible to use a variety of algorithms in the reader 100 to successfully acquire (or demodulate) all of the data from the tags. The general idea in this case is to wait for each tag to choose a unique (that is, single user occupied) communications channel in at least one of the passes of the
30 multiple pass source device transmission algorithm. This technique is generally

the lowest complexity identification method available in the reader 100, though it is also generally the slowest (i.e., requires the longest total transmission time to communicate a piece of information).

One very low complexity algorithm for the case of when no collision mitigation techniques are utilized by the reader 100 is to simply have the tags 110, 120, 130 transmit the maximum number of passes in the multiple pass communications algorithm. The maximum number of passes is typically determined (as described above) when the unique portions of the data stored on the tag is exhausted.

As noted above, the reader 100 directly controls the number of passes that the tags transmit on by controlling the first and second predetermined transmission conditions. In the preferred embodiment of the present invention, the reader transmit power level is held constant in order to continue transmissions among fully activated tags, though other first and second predetermined transmission conditions are possible to control the groups of transmissions from the tags. The maximum number of passes is generally determined by the particular channel selection algorithm, but is generally limited to the data length (in bits) divided by the sum of the channel selection portions of data (in bits) for completely unique (non-overlapping) channel selection choices. Thus, in the example given above with 128-bits of data, and 8-bits of channel ID selection data in each pass, there is a maximum of 16 (i.e., $128/8$) communications passes in the multiple pass algorithm (before the channel choices start to repeat again). Thus, given a channel (e.g., PN) symbol rate in the preferred embodiment, the maximum interrogation time can be determined, and the total acquisition (or reading) time is fixed for all cases (as also illustrated in the equations above).

Other (in many cases more complicated) algorithms that use no collision mitigation techniques are also possible. One such alternative is to have the tags 110, 120, 130 transmit for a limited number of passes (less than the maximum), such that a given confidence level is obtained that the received data (or taken tag inventory) is correct. This is generally determined by the expected number of

source devices (or tags) present in the system (or at each power-on level), and the desired confidence level (or probability of successfully identifying the items or tags in the system). For instance, with the dynamic channel profile given in the example above, simulations (over 1000 trials) have shown that it takes an average of 7.73 transmission passes to identify 50 tags, though a maximum of 10 passes was required to uniquely identify tags in 1000 trials. Thus, the reader 100 could remain powered up at a given power level for 10 passes to have a reasonable confidence that all of the 50 (or so) tags have successfully transmitted their data on a unique channel. Once again, the reader 100 would only have to be able to determine when there is only one tag on a channel to receive its ID data. This would result in a substantial total acquisition time-savings, since only 10 passes were performed instead of the absolute maximum of 16 passes given in the example above. Further simulations, statistical or probability analysis could be applied to determine other confidence levels or the number of passes for a given number of tags. Note that in some applications, the reader 100 could utilize the maximum number of passes the first time it takes an inventory, and then adjust the number of passes based on the expected (i.e., measured or observed) number of tags present in the system.

Alternatively, the algorithm used by the reader 100 could keep track of expected collision locations (i.e., channels) for each tag (once its data or ID information has been successfully received), and estimate how many tags are left to be identified in the system. Thus, the reader 100 may be able to stop the interrogation process sooner than the techniques described above (once it determines that no other tags are likely present in the system). In other words, the required number of transmission passes is adaptively estimated by the reader 100 during reception, instead of being pre-computed based on the expected number of tags as described above. This technique is further described in the examples below, and in FIG. 22.

A more advanced embodiment of the reader 100 may utilize any one of several forms of collision mitigation techniques. Collision mitigation techniques

generally lessen the impact of collisions on a given communications channel. Ideally, they remove the effects of a particular collision on a channel. This can be accomplished in the described system by (at least conceptually) regenerating a known signal and subtracting the known signal from the total signal population (or composite received signal). Note that this interfering signal subtraction may occur at any stage in the demodulation process (e.g., it may occur at the chip-rate or it may occur after despreading in the preferred embodiment). The preferred embodiment of the present invention performs collision mitigation after demodulation (i.e., despreading) in order to reduce the implementation complexity.

In general, the more signals that are known, the fewer tags appear to be present in the system for a given pass of the multiple pass algorithm, when utilizing collision mitigation techniques. Since the data stored on the tag 110 directly determines the channel selection in the preferred embodiment (or it is otherwise known by the reader 100), once the reader 100 has successfully received the data (generally occurring when the tag 110 transmits on an otherwise unoccupied channel), it knows all of the channel choices that the tag 110 will make for every pass of the multiple pass communications algorithm. Thus, the reader 100 can then predict what channels the tag 110 will utilize for future (and past) transmissions, as above. Note that the observed signal levels from the tag 110 are also generally measured (and low pass filtered) in the reader 100 during the normal signal detection process so a reliable estimate of a given (non-colliding) tag's actual signal strength is available. This knowledge can be utilized to effectively re-create the known signal and accurately subtract it out from the aggregate received signal, thereby removing its effect from other transmission passes.

Generally speaking, a family of collision mitigation techniques exists of varying levels of complexity, and they are generally more complex (e.g., require more processing power, memory or hardware) than implementations that do not utilize collision mitigation techniques. However, such techniques generally result

in much shorter total tag data acquisition (reading) times, and can greatly increase system capacity. Once again, it is assumed that the channel is quasi-static, and the system is relatively linear for best system performance.

A relatively simple form of collision mitigation involves subtracting
5 known signals from subsequent passes of the multiple pass algorithm (in a forward direction with respect to time). Thus, this form of collision mitigation is generally termed forward collision mitigation. FIG. 20 shows an example flow chart for reader processing using forward collision mitigation techniques, where the processing is performed in a sequential (e.g., one channel at a time) fashion in
10 order to ease understanding of the process. The process generally involves determining which tags 110, 120, 130 have successfully transmitted their ID data (as described in the receiver algorithms above), and keeping a data structure (or list) containing known (tags') channel choices and estimated signal levels for each pass of the multiple pass algorithm. Once a tag's ID data and the signal level of a
15 transmitted tag signal are known, it can effectively be removed from any subsequent collisions involving that tag. Note once again, that the signal level can be measured and filtered over increasing lengths of time to obtain increasing levels of accuracy of the interfering signal level. Thus, in one embodiment of the present invention, once a tag signal is estimated (determined within some level of
20 accuracy), it is subtracted out from the proper (pre-determined) channels in later passes of the multiple pass transmission algorithm, negating any interfering effects of that (known) tag's signal on other signals transmitted by other users. This technique is made possible due to the deterministic nature of each tag's channel choices, which are typically based on the data stored on the tag 110.

25 The quasi-static channel assumption becomes important here since the measured signal level will be assumed to hold for all subsequent passes. In general, the signal level estimate could be updated every transmission pass to account for slowly varying channel conditions. Note that only the known tag signal information (typically contained in a data structure or list) and the
30 composite received signal from the current transmission pass (or burst) needs to

be stored to perform this algorithm (as opposed to storing all received bursts in memory as described in the algorithm below). In general, this type of forward collision mitigation algorithm can result in a significant (2-4X) total reading time improvement over methods that do not perform any collision mitigation.

5 Another more advanced form of collision mitigation involves subtracting known signals from both subsequent and previous passes of the multiple pass transmissions. This is possible because, once the data from a tag 110 is identified, the channels it occupied on previous passes can be ascertained and its contribution to any previous collisions can be nullified. This class of collision mitigation
10 algorithms is generally termed as bi-directional collision mitigation techniques. Bi-directional collision mitigation is more computationally complex (and generally requires more memory to store prior communication passes), but results in greatly reduced total tag reading time (reduced by roughly an order of magnitude over methods that do not perform any collision mitigation).

15 Generally, this method requires storing a data structure containing known channel choices and estimated signal levels in each communications pass (as in the case above) for identified tags. However, since signals are subtracted out from prior transmission passes (in addition to the current pass as in forward collision mitigation algorithms), additional collisions can be resolved. For
20 example, if data from the third pass of the multiple pass communications algorithm is resolved (i.e., successfully received), it may result in the data from another user being resolvable in a prior pass (e.g., the second pass) of the algorithm, which in turn may free up another user that was previously colliding in either a prior (e.g., the first pass) or subsequent pass (e.g., the third pass) of
25 transmissions. Every time data from a new user is resolved, its reconstructed signal is subtracted from all transmission passes (up to and including the current pass), and the number of collisions is evaluated again (for all possible communications channels). In this manner, the reader 100 may cycle through all of the available transmission passes (up to and including the current pass), and
30 resolve more tag signals virtually continuously, until a point is reached where no

more users can be resolved in any of the passes (up to and including the current pass). The reader 100 would then step to the next power level and continue with the bi-directional collision mitigation algorithm. The effect can be quite powerful in later transmission passes, allowing a number of tag signals to be resolved which is much greater than the available number of communications channels.

Once all of the tag data has been received, the reader 100 may check the integrity of the data via the means mentioned above (e.g., error detection and correction). The reader 100 may also post-process the data, which typically includes functions such as descrambling, de-encryption, classification, and removal of redundant items (which power up in more than one power-on range in the preferred embodiment of the present invention). Note that some or all of these functions could take place at a centralized location, thereby serving multiple readers or antennas.

Examples of System Operation

The operation of these algorithms is perhaps best conveyed by way of examples. The examples will detail a simplified, hypothetical system of tags that draw random channels each pass. FIGs. 21, 23, and 24, which will be used to explain the example, are a state diagram of the system, showing which channel each tag picks to communicate over on each subsequent pass through the algorithm. The states in the example are unaltered outputs of an actual experiment using a random number generator to choose the channels. The type of physical channel (e.g., code phase, time slot, etc.) is irrelevant at this point. This should provide a relatively accurate model of the overall system because of the data scrambling portion of the present invention as detailed in Section I above.

The example detailed in FIGs. 21, 23 and 24 assumes a population of eight tags, and further assumes a fixed channel size per pass of eight channels from which the tags may draw from to communicate. Thus, three-bits of (a unique subset of) each tag's ID information is used to select one of eight channels that

each tag 110 will transmit on during each pass of transmission in the preferred embodiment. With octal digits, the first thirty bits of the tags ID's were randomly

generated and are repeated below for convenience:

5 Tag 1: 0033 0436 07...
 Tag 2: 1106 2551 65...
 Tag 3: 4767 4416 41...
 Tag 4: 2044 6111 36...
 Tag 5: 6072 3355 74...
 Tag 6: 1476 5432 40...
 Tag 7: 5443 3675 34...
 Tag 8: 2135 5115 64...

10 Tag 1 will choose channel 0 during Pass #1, channel 0 during Pass #2,
 channel 3 during Pass #3, and so on. Tag 2 will choose channel 1 during Pass #1,
 channel 1 during Pass #2, channel 0 during Pass #3, and so on. From this list, it
 can be seen that, for Pass #1, which draws a channel from the first octal digit, tag
 1 is the sole occupant of channel 0, tag 3 is the sole occupant of channel 4, tag 5 is
 15 the sole occupant of channel 6, and tag 7 is the sole occupant of channel 5. Since
 there are no collisions in these channels, tags 1, 3, 5, and 7 are successfully
 identified in their entirety; tags 1, 3, 5 and 7 communicated their full ID in a
 channel that had no collisions. On Pass #1, however, tags 2 and 6 collided in
 channel 1, and tags 4 and 8 collided in channel 2. These tags cannot be
 20 successfully identified, and will require subsequent passes to be resolved. The
 reader 100, observing that collisions exist, leaves the power applied at the present
 level and allows all of the tags to draw another channel from the second octal digit
 for Pass #2. It should be noted that none of the tags know whether they have
 successfully communicated their ID.

25 In Pass #2, the only tag not involved in a collision is tag 3. Since this tag
 was already identified in Pass #1, the reader 100 did not acquire any new
 information. None of the tags that were in collisions in Pass #1 can yet be
 identified. Statistically, for eight tags and eight channels, there is a $1 - 8!/8^8 =$
 99.76% probability that there will be at least one collision. This result comes
 30 from the more general case of the probability of no collision between M tags over
 N channels given above:

$$P\{no\ collision\} = \frac{N!}{(N-M)!} \frac{1}{N^M}$$

and the fact that $P\{collision\} = 1 - P\{no\ collision\}$. There will be this same probability of at least one collision for each pass through the algorithm. For this combination of tags and channels, averaged over 100,000 experiments, 2.7498 of the eight channels are unoccupied per pass, 3.1386 of the channels contain a single tag, 1.5737 channels contain two tags, 0.4482 channels contain 3 tags, 0.0796 channels contain 4 tags, 0.0093 channels contain 5 tags, 7.2×10^{-4} channels contain 6 tags, 4×10^{-5} channels contain 7 tags, and no cases of eight tags in one channel were recorded.

10

No Collision Mitigation Example

With no collision mitigation, tags have to show up in a channel all by themselves in order to be identified. If the experiment is allowed to run enough times, this will happen. However, with only a limited number of bits in the tag ID information, the experiment can only be run a limited number of times before it starts repeating. For example, if the tag ID was 96-bits long, and three bits per pass were used to draw a channel (one of 8), then after 32 experiments the process would repeat. Since there is a high probability of at least one collision per pass (99.76% for this scenario), there is a small but finite probability that a tag's ID can 'hide' in collisions on each and every pass through the experiment. This does not mean that a tag's ID is identical to a different tag's ID over the entirety (which is not allowed by the assumption of unique tag ID's and a unique, reversible mapping to a scrambled tag ID). All that it means is that the tag's ID is identical to at least one other tag's ID when examined over the small number of bits (in this case, three) being used to define the channel space for that pass. This introduces the concept of inventory or item uncertainty, where an inventory of tags is known only to a certain confidence.

25

For the example experiment in FIG. 21, eight trials are required for each tag to make an appearance in a collision-free channel. As already mentioned, tags 1, 3, 5 and 7 are identified in Pass #1, tag 2 shows up in Pass #3, tags 4 and 8 are identified in Pass #4, and tag 6 does not show up until Pass #8. Tag 6 is a good
5 example of how a unique tag can be hidden in collisions even though it has a unique ID. If this experiment had only been run through Pass #7 (i.e., if the IDs were only 21 bits long), tag 6 would not have been identified.

In Pass #1, four tags are identified. Two collisions are also identified, indicating that there are at least four other tags (since it takes at least two tags to result in a single collision, it takes at least 4 tags to result in two collisions). So
10 after the first pass, the reader 100 can determine that there are four known tags and at least four unknown tags, or at least eight tags in total.

In Pass #2, only a single, previously known tag is occupying a unique (unused) channel. Since the reader 100 knows the complete ID for tags 1, 3, 5
15 and 7, it knows what channels these items will be occupying in the next and all subsequent passes. The reader 100 knows that tags 1 and 5 will go to channel 0, and that tag 7 will go to channel 4. The reader 100 thus expects there to be a collision on channel 0, but there is a possibility that there is also an unknown tag that is occupying channel 0 (in this case, tag 4). Channel 0 indicates two known
20 tags and a potential for one or more unknown tags. The reader 100 was not expecting a collision on channel 1 (since none of the known tags were expected to choose that channel). A collision here indicates at least two more unknown tags, with perhaps more. A collision on channel 4, where only tag 7 was expected, indicates at least one other unknown tag. Thus, Pass #2 results in four previously
25 known tags, with at least three (definitely) unknown tags. This is less than the set defined by the first pass, which was four known tags and at least four unknown tags, so the reader 100 gathered no new information in the second pass.

In Pass #3, tag 2 is identified on channel 0. Tag 1 was the only tag expected to go to channel 3, so a collision there indicates at least one unknown
30 tag. Tag 7 was the only item expected to go to channel 4, so a collision there

indicates at least two unknown tags (the unknown tag on channel 3 and the unknown tag on channel 4). Tag 3 is again by itself. Tag 5 was the only tag expected to go to channel 7. A collision there indicates at least three unknown tags (counting the unknown tags on channels 3, 4 and 7). These, along with the
5 now five known tags, again indicate at least eight tags.

Pass #4 identifies new tags 4 and 8. Tags 3, 5 and 7 turn up in collision-free channels. Tags 1 and 2 were expected to collide on channel 6, but there may be additional tags there. This leaves seven known tags, and from previous experiments, at least one unknown tag.

10 Pass #5 identifies no new tags. The collision on channel 5 was unexpected, again indicating seven known tags and at least one unknown tag. Similar interpretations can be made from Pass #6 and Pass #7.

In Pass #8, tag 6 is identified. All other collisions were expected. There are now eight identified tags, the minimum number expected from previous
15 passes. However, there could still be tags hidden in the collisions. For example, there could be a tag that chose channels 1, 0, 4, 6, 3, 1, 1, 5, and this tag would be hidden by other collisions. The probability that a tag would have this particular ID would be $1/8^8$ or 6×10^{-8} .

There could also be a tag that chose channels e.g., 2, 4, 4, 6, 5, 4, 5, 6, also
20 with probability 6×10^{-8} . In all, with two collisions during Pass #1, three collisions during Pass #2, three collisions during Pass #3, one collision during Pass #4, two collisions during Pass #5, two collisions during Pass #6, three collisions during Pass #7, and three collisions during Pass #8, there are $2 \times 3 \times 3 \times 1 \times 2 \times 2 \times 3 \times 3 = 648$ possible hidden ID's, each with probability 6×10^{-8} , for a
25 probability of an additional single hidden tag of $648/8^8 = 38.6 \times 10^{-6}$ (38.6 ppm). The probability of an additional two hidden tags would be even smaller, $648 \cdot 647/8^{16} = 1.5 \times 10^{-9}$. The level of inventory confidence could be further improved in other embodiments by unscrambling the data and determining, for

example, that the hidden tag would be associated with a tire or some other unexpected item when all the other items were grocery items.

The probability of a hidden tag can be reduced by allowing the experiment to keep running after it has identified the minimum number of expected tags based on collision information (in this case, 8 tags). By counting the number of collisions per pass, and knowing the probability of a hidden tag based on the number of channels per pass, the reader 100 can keep running passes until it has satisfied some confidence level or has run out of unique channel patterns (exhausted the ID). Assuming $648^{1/8} = 2.246$ collisions per pass, after two additional passes (10 total passes), the probability of a single hidden tag is reduced to 3.04×10^{-6} . After two more additional passes (12 total), the probability of a single hidden tag is reduced to 240×10^{-9} . Each additional pass reduces the probability of a single hidden tag as a geometric progression by roughly $648^{1/8} = .281X$.

A flow chart showing the steps involved in the no-interference cancellation method described above appears in FIG. 22. At the start 2210, the system is initialized with no positive ID's and no unknowns, which together corresponds to a total of zero items. After the analysis 2230 of the first pass 2220, positive ID's (e.g., items 1, 3, 5 and 7 in Pass #1) are recorded and added 2240 to the list of positive ID's. The number of collisions in the pass 2250 is also recorded (e.g., two collisions in Pass #1). If the collisions were anticipated 2260, then there are potential unknowns that may be revealed in future passes but no definite unknowns. If the collisions were not anticipated 2270, the two unknowns are added to the unknown list. The total number of items is then estimated 2280 to be the positively identified items and the minimum number of unknowns that could cause the recorded collisions. Assuming the positive ID's do not equal the estimated total items, the unknowns total is reset to zero 2295 and another pass 2220 is initiated. The loop is finally exited 2290 when the number of positive

ID's equals the maximum number of previously identified ID's plus unknowns, and a predetermined confidence level 2296 is satisfied.

So far, no assumptions have been made about the time variations of the channel and the received signal levels. The "no collision mitigation method" can be applied whether the channel is static or dynamic. For the case of static channel conditions, where the return signals have a consistent power level and phase, more information is available at the reader 100 in the form of received signal level. If it is now assumed that, in addition to knowing what channel a known tag will choose on future passes, its signal level is also known, then it can be determined whether there are additional hidden tags in expected collisions. For example, the collision on channel 0 during Pass #2 contained two known tags and one unknown tag. If the signal levels of the known tags were also known, then the total signal level of the collision could be compared to the individual signal levels to determine if there was an additional unknown tag concealed in the collision. Such an environment would allow the reader 100 to terminate its inquiry after all tags had been independently identified (in this case, 8 passes) with certainty that there were no hidden tags because all collisions would be accounted for.

Knowledge of the signal level of identified tags thus offers a greater confidence in the accounting of the inventory. However, the signal level information affords improvements in acquisition time beyond merely terminating the inquiry after all known tags appear individually. This is discussed in the next section.

Forward Collision Mitigation Example

When a tag is individually identified, its channel choices for all subsequent passes are known at the reader 100. If the signal level and phase of the tag are additionally known, then the contributions of that tag to collisions can be nullified. The signal from the tag can essentially be removed from subsequent collisions, thereby effectively removing it from the population. Consider the

experiment shown in FIG. 23. Tags 1, 3, 5 and 7 are positively identified during Pass #1. Assume their signal levels and phases are also determined.

During Pass #2, tags 1 and 5 are known to transmit their data over channel 0. With their known signal level, they can be subtracted out, leaving behind only tag 4 that can now be identified. Likewise, tag 7 was expected to transmit its data over channel 4 during Pass #2, and by canceling out this tag, tag 6 is left alone to be identified. There is still an unresolved collision on channel 1, so at least one other pass through the algorithm is required.

During Pass #3, tag 2 shows up by itself and is identified. Tag 1 was expected to transmit its data over channel 3, so it is subtracted out, leaving behind only tag 8, which can now be identified. All other collisions contain only known tags, so the accounting of the tags has been completed in three passes through the algorithm with full confidence instead of eight or more passes (depending on the confidence level required) for no collision mitigation as in FIG. 21.

For a static channel, the signal strength of identified tags can be known to a high precision. Consider the case of an augmented PN channel. For this experiment, the tags would choose different code phases of an eight-chip long augmented PN sequence. This eight-chip long PN sequence would be transmitted either true or inverted for each bit of the tag's ID, depending on the sense of the particular ID bit. At the reader 100, the correlator in the receiver would essentially average the signal level over the eight chips per bit. This would be done for all bits (e.g., 128) in the ID, giving an average over $8 \times 128 = 1024$ samples, for a signal to noise ratio averaging gain of $10 \log(1024) = 30$ dB. For more practical cases where there are many more expected tags and many more channels available (> 32), the gain increases. For 32 channels and 128 bits, a gain in signal-to-noise ratio of 36 dB results.

Bi-Directional Collision Mitigation Example

Even greater improvements in accounting time can be made if the reader
100 stores waveform samples from previous passes. With a stored waveform,
previous passes can be revisited and treated as subsequent passes, from which
5 previous collisions can be cancelled out. This is because once a tag is identified,
not only are all subsequent activities known, but all previous channel choices and
signal levels would also be known.

Consider the example shown in FIG. 24. During Pass #1, tags 1, 3, 5 and
7 are identified in both bit pattern and signal level and phase. As with forward
10 collision mitigation, tag 4 can be identified in Pass #2 since the effects of tags 1
and 5 can be removed from the collision on channel 0. Likewise, removing the
effects of tag 7 from the collision on channel 4 allows identification of tag 6.
After Pass #2 and the application of forward collision mitigation, tags 1, 3, 4, 5, 6
and 7 are known.

15 Instead of needing the third pass, the results of Pass #1 may be revisited
after applying forward collision mitigation. With tag 4 identified during Pass #2,
it can be removed from channel 2 of the stored results of the first pass to resolve
tag 8. With tag 6 identified during Pass #2, it can also be removed from channel
1 of the stored results of the first pass to resolve tag 2. In this case, only two
20 passes are required to successfully identify all eight tags. The benefits of both
forward and bi-directional collision mitigation become more significant when
larger numbers of channels and tags are involved.

Thus, a one-way communications system utilizing a multiple pass
transmission algorithm (preferably employing spread spectrum techniques) that
25 offers superior performance (e.g., reading time and capacity) has been fully
described. The incorporation of collision mitigation techniques, dynamic channel
profiles, and power on ranges further improves system performance. The
described communication system has many applications that are not limited to the
preferred embodiment and actual examples detailed in the text. The present

invention also has applications in two-way communications devices, actively powered user devices, and networked devices without departing from its essential characteristics (described in the claims below).

The present invention may be embodied in other specific forms without
5 departing from its spirit or essential characteristics. The described embodiments are to be considered in all respects only as illustrative and not restrictive. The scope of the invention is, therefore, indicated by the appended claims rather than by the foregoing description. All changes that come within the meaning and range of equivalency of the claims are to be embraced within their scope.

Claims

We claim:

1. A method comprising the steps of:
5 storing predetermined data;
establishing a channel selection profile comprising a plurality of channel selections, wherein each channel selection is derived from a subset of the predetermined data; and
transmitting at least a portion of the predetermined data
10 over at least a first channel selected from the channel selection profile.
2. The method of claim 1 wherein each channel selection is derived from a unique subset of the predetermined data
15
3. The method of claim 1 wherein the step of transmitting commences after a predetermined condition is satisfied.
4. The method of claim 3 further comprising the step of
20 receiving a power level, and wherein the predetermined condition is satisfied when the power level exceeds a predetermined threshold.
5. The method of claim 1 further comprising the step of
25 ceasing the step of transmitting when a predetermined condition is satisfied.
6. The method of claim 5 further comprising the step of
30 receiving a power level, and wherein the predetermined condition is satisfied when the power level exceeds a predetermined threshold.

7. The method of claim 5 further comprising the step of receiving a power level, and wherein the predetermined condition is satisfied when the power level falls below a predetermined
5 threshold.
8. The method of claim 1 wherein a first channel selection in the channel selection profile is selected from a first set of channels, and a second channel selection in the channel selection profile is
10 selected from a second set of channels, wherein a number of channels in the first set of channels is different from a number of channels in the second set of channels.
9. The method of claim 1 further comprising the step of
15 randomizing the predetermined data prior to establishing the channel selection profile.
10. The method of claim 9 wherein the step of randomizing is based on at least one of the following algorithms: a scrambling
20 algorithm, an encryption algorithm
11. The method of claim 1 wherein the step of transmitting utilizes spread spectrum modulation.
- 25 12. The method of claim 1 wherein the plurality of channel selections are uniformly distributed.

13. A device comprising:
a storage medium for storing predetermined data;
a channel selector, coupled to the storage medium, for
generating a channel selection profile comprising a plurality of
5 channel selections, wherein each channel selection is derived from
a subset of the predetermined data; and
a transmitter, coupled to the storage medium, for
transmitting at least a portion of the predetermined data over at
least a first channel selected from the channel selection profile.
10
14. The device of claim 13 wherein the first channel selected
from the channel selection profile is orthogonal to a second
channel selected from the channel selection profile.
- 15 15. The device of claim 13 wherein the first channel selected
from the channel selection profile is quasi-orthogonal to a second
channel selected from the channel selection profile.
16. The device of claim 13 wherein a channel selected from the
20 channel selection profile utilizes a specially augmented
pseudonoise sequence.
17. The device of claim 13 wherein the device is at least one of
the following: an active device, and a passive device.
25

18. A system comprising a plurality of first devices in communication with a second device, wherein each first device stores predetermined data, establishes a channel selection profile comprising a plurality of channel selections, and transmits at least a portion of the predetermined data over at least a first channel selected from the channel selection profile, and wherein each channel selection is derived from a subset of the predetermined data, and wherein at least two first devices transmit synchronously.
19. The system of claim 18 wherein at least two first devices transmit simultaneously.
20. The system of claim 18 wherein the second device performs a collision mitigation technique.
21. The system of claim 18 wherein at least one first device continues to transmit at least a portion of the predetermined data over a channel selected from the channel selection profile for a number of passes, wherein a new channel is selected during each pass.
22. The system of claim 21 wherein the second device controls the number of passes.
23. The system of claim 21 wherein the number of passes is known *a priori* to the second device.
24. A correlation method comprising the steps of:
receiving a signal sequence;
re-ordering the signal sequence based upon a predetermined order; and

performing a transform on the re-ordered sequence.

25. The method of claim 24 wherein the transform is selected from a group consisting of: Fast Hadamard Transform (FHT), Fast Walsh Transforms, Fast
5 Walsh-Hadamard Transform.
26. The method of claim 24 wherein the signal sequence comprises at least one m-sequence.
- 10 27. The method of claim 26 wherein the predetermined order is based on a generator polynomial of at least one m-sequence.
28. The method of claim 24 wherein the signal sequence comprises at least one specially augmented m-sequence.
15
29. The method of claim 28 wherein the predetermined order is based on a generator polynomial of at least one specially augmented m-sequence.
30. The method of claim 24 wherein a dimension of the transform is
20 equivalent to a number of available channels.
31. The method of claim 24 wherein a dimension of the transform is different than a number of available channels.
- 25 32. A device comprising:
a receiver for receiving elements of a signal sequence;
a state generator for generating a sequence of addresses to translate
between a pseudonoise sequence and a Walsh sequence; and

a storage medium, coupled to the receiver and the state generator, for storing each element of the signal sequence at a given address according to the sequence of addresses.

5 33. The device of claim 32 wherein the state generator comprises a linear feedback shift register.

34. The device of claim 33 wherein the linear feedback shift register is a Fibonacci sequence generator.

10

35. The device of claim 32 wherein the state generator is a second storage medium.

15 36. The device of claim 32 wherein the pseudonoise sequence is a specially augmented m-sequence.

37. The device of claim 32 further comprises a processor, coupled to the storage medium, for performing a transform on at least a portion of the elements of the signal sequence stored in the storage medium.

20

38. The device of claim 37 the transform is selected from a group consisting of: Fast Hadamard Transform (FHT), Fast Walsh Transforms, Fast Walsh-Hadamard Transform.

25 39. The device of claim 32 wherein the receiver comprises an analog-to-digital converter.

40. A scrambling method comprising the steps of:
dividing a set of data into a first portion and a second portion;

performing a first scrambling method on the first portion of the set of data to create a scrambled first portion of the data;

modifying the second portion of the set of data with the scrambled first portion of the set of data to create a modified second portion of the set of data;

5 performing a second scrambling method on the modified second portion of the set of data to create a scrambled second portion of the set of data; and

modifying the scrambled first portion of the set of data with the scrambled second portion of the set of data to create a scrambled set of data.

10 41. The scrambling method of claim 40 wherein the first and second scrambling methods recursively execute the steps of claim 40 until the set of data reaches a predetermined length.

15 42. The scrambling method of claim 41 wherein the predetermined length is one byte.

43. The scrambling method of claim 41 further comprising the step of performing a predetermined function on the set of data once the set of data reaches the predetermined length.

20

44. The scrambling method of claim 43 wherein the predetermined function is an invertible function.

25 45. The scrambling method of claim 44 wherein the invertible function is a lookup function.

46. The scrambling method of claim 40 wherein the steps of modifying are invertible.

47. The scrambling method of claim 40 wherein the steps of modifying are selected from a group consisting of: exclusive-or, modular addition, and modular subtraction.
- 5 48. The scrambling method of claim 40 further comprising the step of programming the scrambled set of data onto a device.
49. The scrambling method of claim 40 wherein the first and second scrambling methods are cryptographic algorithms.
- 10 50. A descrambling method comprising the steps of:
dividing a set of data into a first portion and a second portion;
modifying the first portion of the set of data with the second portion of the set of data to create a modified first portion of the set of data;
15 performing a first descrambling method on the second portion of the set of data to create a descrambled second portion of the set of data;
modifying the descrambled second portion of the set of data with the modified first portion of the set of data to create a modified second portion of the set of data; and
20 performing a second descrambling method on the modified first portion of the set of data.
51. The descrambling method of claim 50 wherein the first and second descrambling methods recursively execute the steps of claim 50 until the set of
25 data reaches a predetermined length.
52. The descrambling method of claim 51 wherein the predetermined length is one byte.

53. The descrambling method of claim 51 further comprising the step of performing a predetermined function on the set of data once the set of data reaches the predetermined length.
- 5 54. The descrambling method of claim 53 wherein the predetermined function is an invertible function.
55. The descrambling method of claim 54 wherein the invertible function is a lookup function.
- 10 56. The descrambling method of claim 50 wherein the steps of modifying are invertible.
57. The descrambling method of claim 50 wherein the steps of modifying are selected from a group consisting of: exclusive-or, modular addition, and modular subtraction.
- 15 58. A collision mitigation method used in a communication system, the method comprising the steps of:
- 20 estimating a signal that has been received over a first channel;
 determining a set of channels that the signal will be received over; and
 based on the steps of estimating and determining, removing the signal from a plurality of signals received over a second channel.
- 25 59. The method of claim 58 wherein the step of estimating comprises estimating a received signal strength of the signal.
60. The method of claim 58 wherein the step of estimating utilizes error correction coding.

61. The method of claim 58 wherein the steps of claim 1 are repeatedly performed until all signals are determined.
62. The method of claim 58 wherein the signal represents at least a portion of
5 predetermined data stored on a device.
63. The method of claim 58 wherein the first channel and the second channel are the same.
- 10 64. The method of claim 58 wherein the first channel and the second channel are different.
65. The method of claim 58 wherein the first channel is orthogonal to the second channel.
15
66. The method of claim 58 wherein the first channel is quasi-orthogonal to the second channel.
67. A collision mitigation method used in a multiple pass communication
20 system, the method comprising the steps of:
in a given pass, estimating a signal that has been received over a first channel;
determining a set of channels that the signal was and will be received over in prior and subsequent passes; and
25 based on the steps of estimating and determining, removing the signal from a plurality of signals received over a second channel.
68. The method of claim 67 wherein the signal is removed from at least one of a prior pass and a subsequent pass.
30

69. The method of claim 67 further comprising the step of storing all signals received over their respective channels in each pass.
70. The method of claim 67 wherein in each pass, a plurality of devices
5 transmit their respective signals over their selected channels to a common device.
71. The method of claim 67 wherein the step of estimating utilizes error correction coding.
- 10 72. The method of claim 67 wherein the steps of claim 67 are repeatedly performed until all signals are determined.
73. A collision mitigation method used in a communication system, the method comprising the steps of:
15 receiving a signal over a first channel;
determining a set of channels that the signal will be received over; and
based on the steps of determining, estimating a total number of signals in the system based on a number of known signals and a number of colliding signals.
- 20 74. The method of claim 73 wherein the steps of claim 73 are repeatedly performed until the number of known signals is equal to the estimated total number of signals.
75. The method of claim 73 wherein the steps of claim 73 are repeatedly
25 performed until a predetermined confidence level is obtained.
76. A method comprising the steps of:
receiving a signal over a channel;
estimating a variance of an absolute value of the signal; and

based on the step of estimating, determining that a collision has occurred on the channel when the estimated variance exceeds a predetermined threshold.

77. The method of claim 76 wherein the predetermined threshold is derived
5 from a mean of the absolute value of the signal.

78. A method comprising the steps of:
receiving a carrier signal;
continuously monitoring the carrier signal for a first predetermined
10 condition and a second predetermined condition;
if the first predetermined condition is satisfied, transmitting data;
if the first predetermined condition subsequently is not satisfied, ceasing
transmission of the data; and
if a second predetermined condition is satisfied, ceasing transmission of
15 data.

79. The method of claim 78 wherein the first predetermined condition is satisfied when a received power level exceeds a threshold.

20 80. The method of claim 78 wherein the second predetermined condition is satisfied when a received power level exceeds a threshold.

81. The method of claim 78 wherein the first predetermined condition is satisfied when a predetermined synchronization pulse is received.

25

82. The method of claim 78 wherein the first and second predetermined conditions are random.

83. At least a first device comprising:
A receiver for receiving a carrier signal;
A monitor, coupled to the receiver, for continually monitoring the carrier
signal;
- 5 A storage medium having data stored therein; and
A transmitter, coupled to the receiver, the monitor, and the storage
medium, for transmitting at least a portion of the data when a first and a second
condition are satisfied.
- 10 84. At least the first device of claim 83 wherein the first and second
conditions of a first device are the same as the first and second conditions of a
second device.
85. At least the first device of claim 84 wherein the first and second devices
15 transmit simultaneously.
86. At least the first device of claim 83 wherein the first and second
conditions of a first device are different than the first and second conditions of a
second device.
- 20 87. At least the first device of claim 86 wherein the first and second devices
transmit simultaneously.
88. At least the first device of claim 83 wherein at least one of the first and
25 second conditions are randomly assigned.
89. At least the first device of claim 83 wherein at least one of the first and
second conditions are uniformly distributed.

90. At least the first device of claim 83 wherein the first and second conditions are satisfied when a power level falls within a given range.

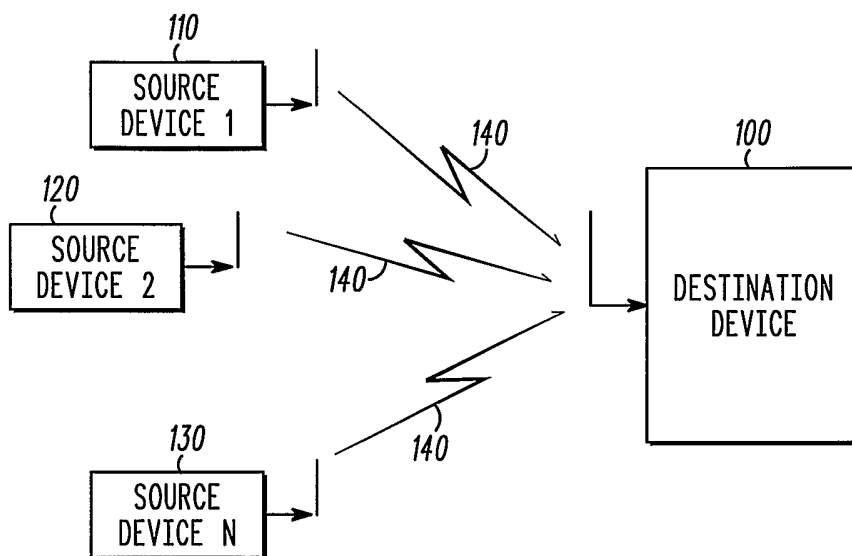

FIG. 1

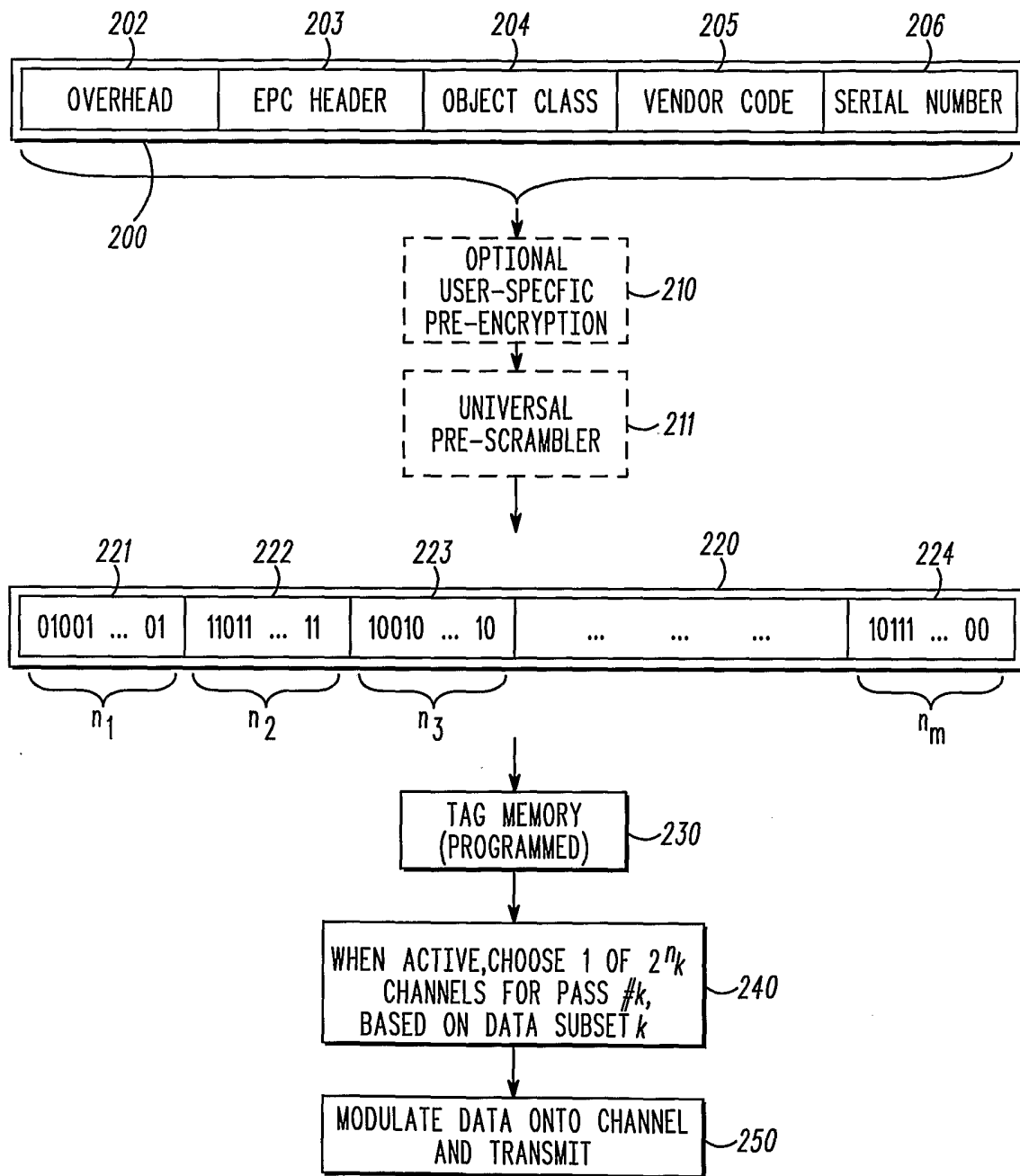

FIG. 2

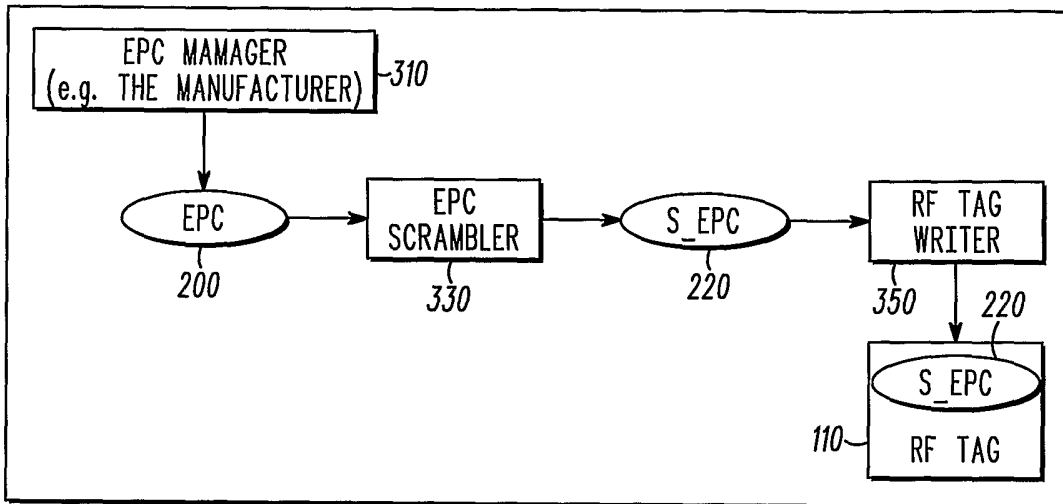

FIG. 3

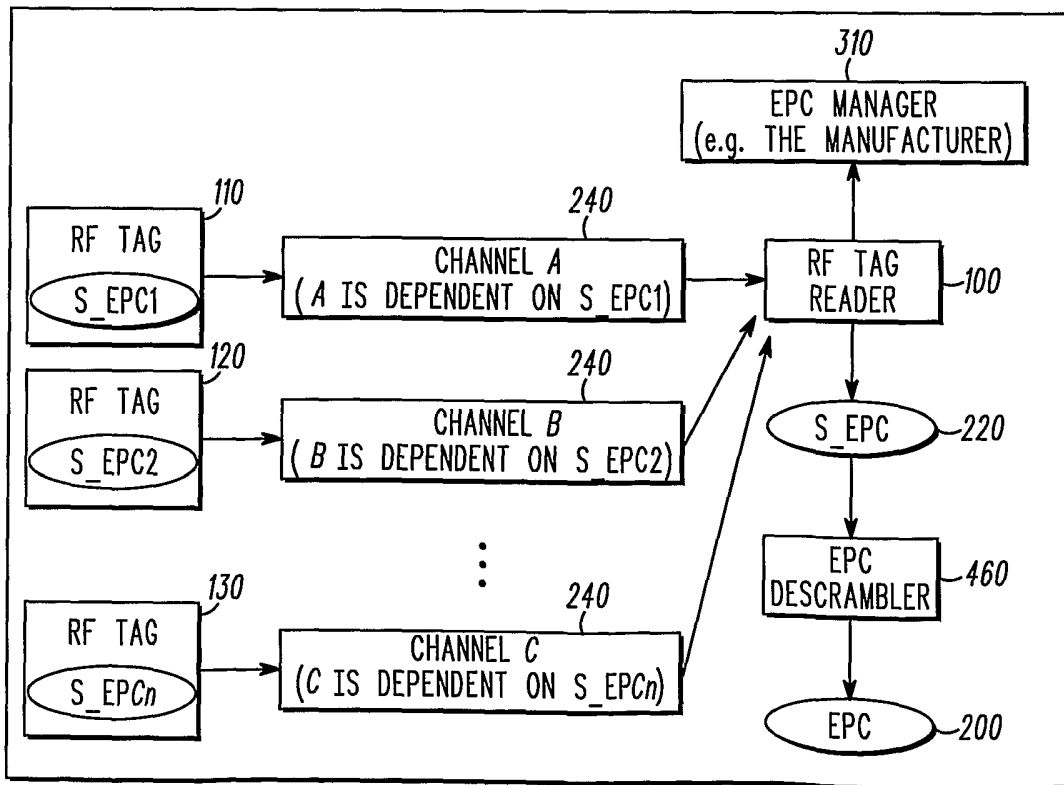

FIG. 4

4/20

```
510 SCRAMBLE (DATA, LENGTH) {  
    IF (LENGTH == 1)  
        RETURN (Sbox [DATA] ) ;  
    DATA. LEFT = SCRAMBLE (DATA. LEFT, LENGTH/2) ;  
    DATA. RIGHT ^= DATA LEFT ;  
    DATA. RIGHT = SCRAMBLE (DATA. RIGHT, LENGTH/2) ;  
    DATA. LEFT ^=DATA. RIGHT ;  
}
```

```
520 DESCRAMBLE (DATA, LENGTH) {  
    IF (LENGTH == 1)  
        RETURN (INVERSESbox [DATA] ) ;  
    DATA. LEFT ^=DATA. RIGHT ;  
    DATA. RIGHT = DESCRAMBLE (DATA. RIGHT, LENGTH/2) ;  
    DATA. RIGHT ^= DATA. LEFT ;  
    DATA. LEFT = DESCRAMBLE (DATA. LEFT, LENGTH/2) ;  
}
```

FIG. 5

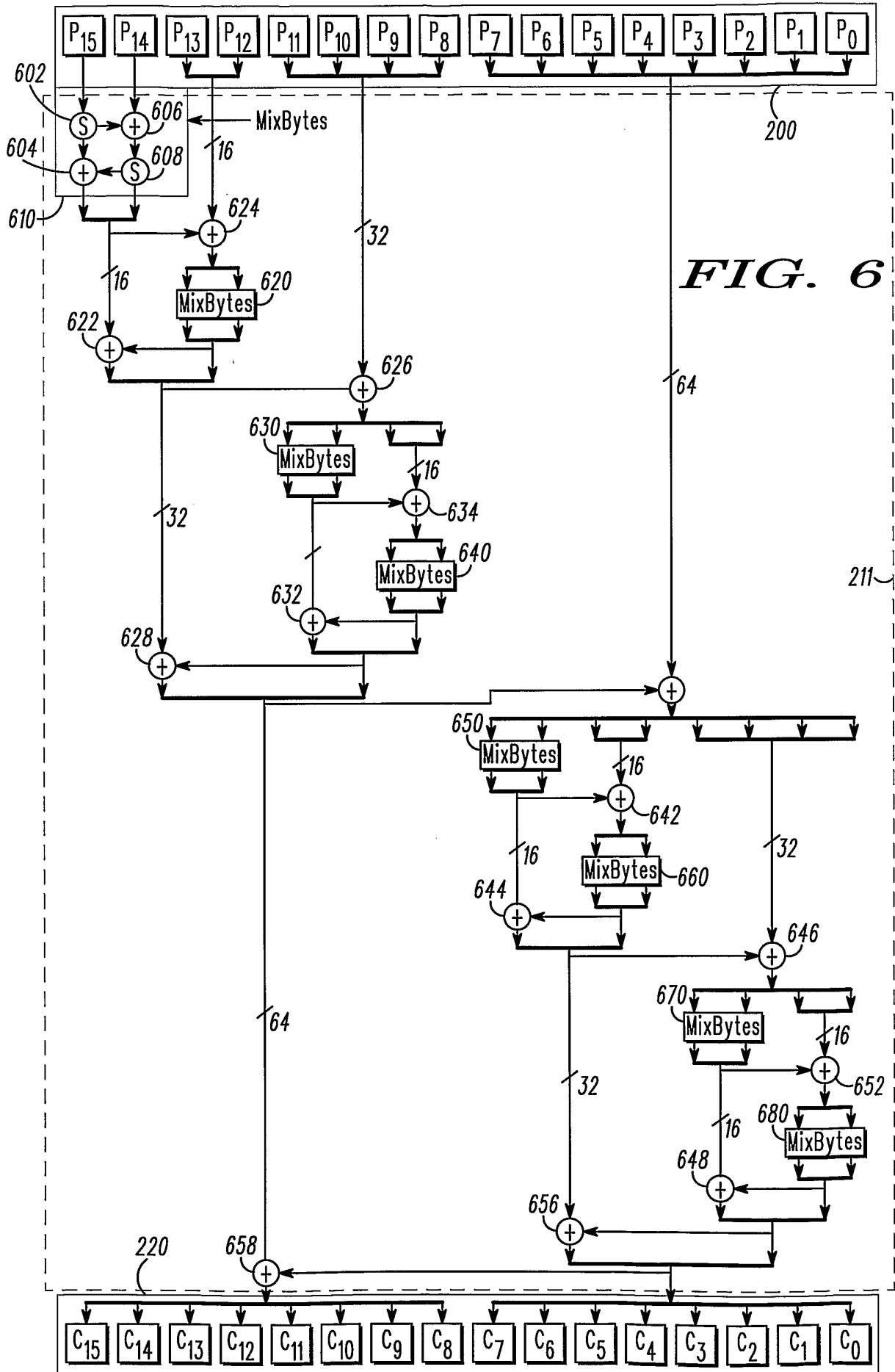

FIG. 6

6/20

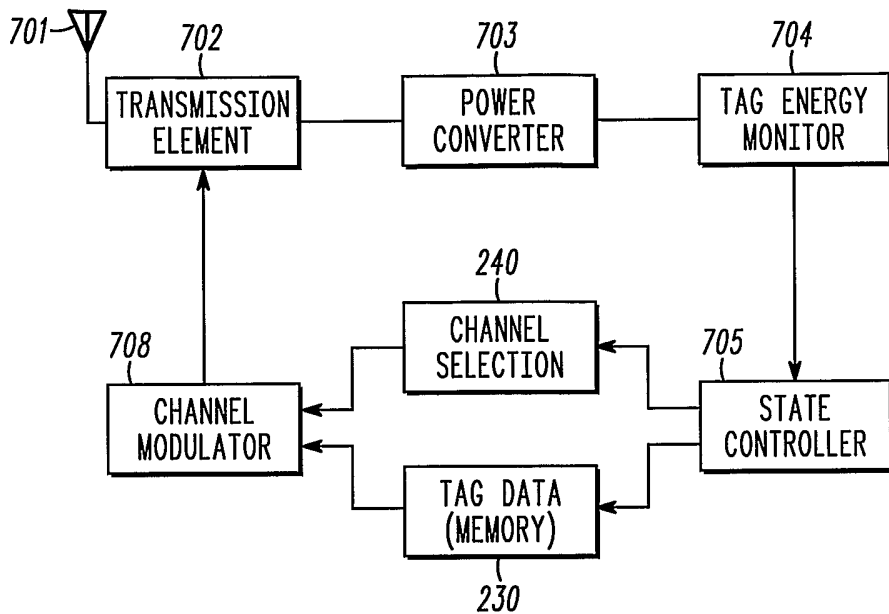

FIG. 7

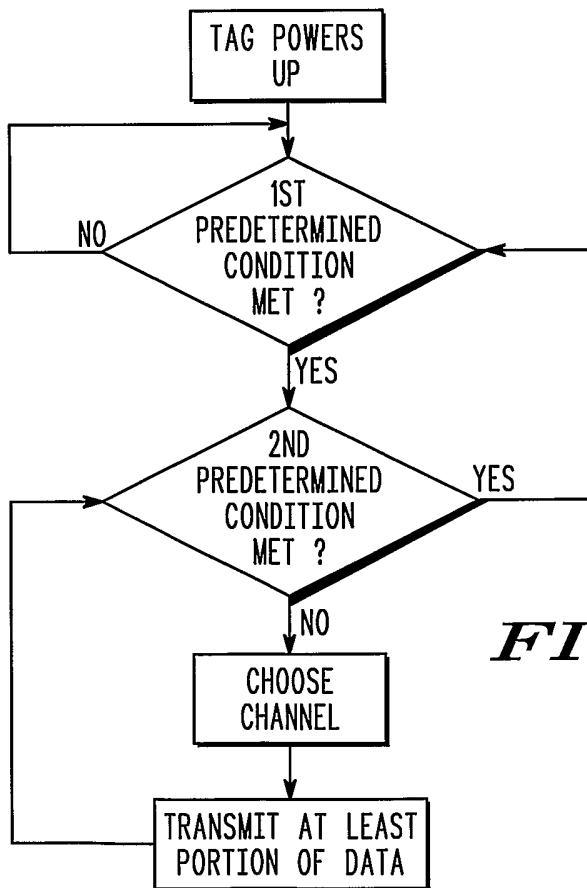

FIG. 8

7/20

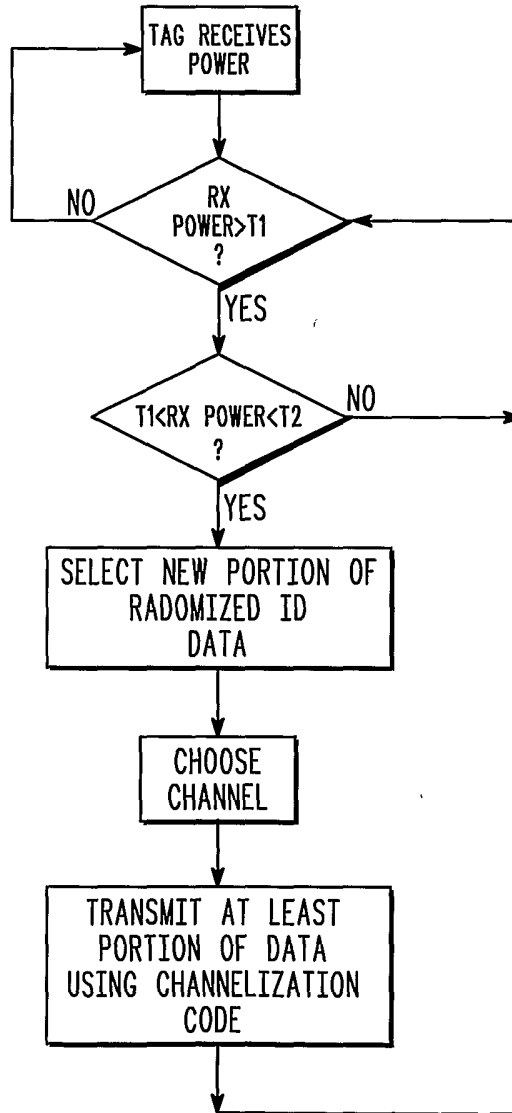

FIG. 9

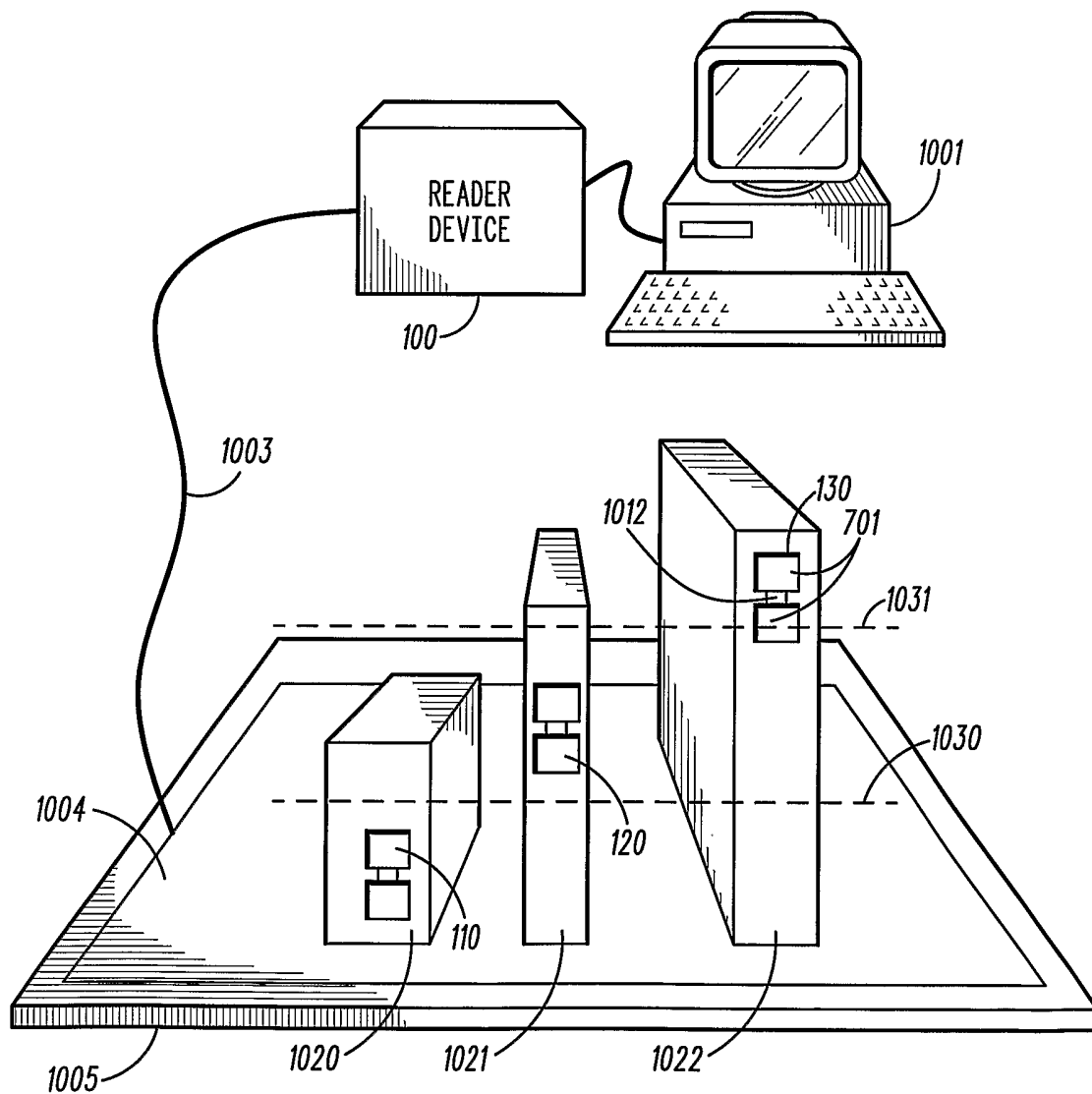

FIG. 10

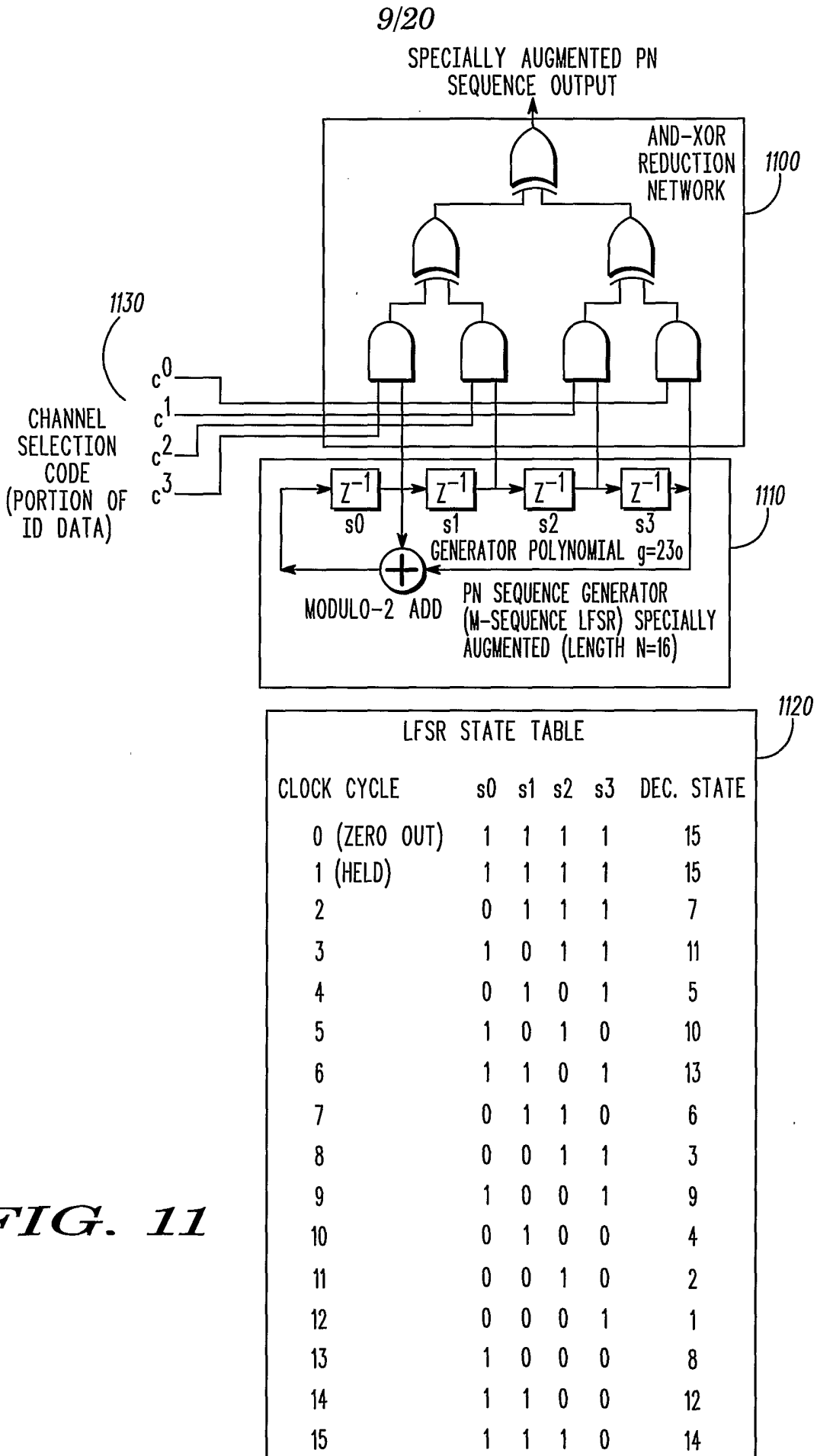

FIG. 11

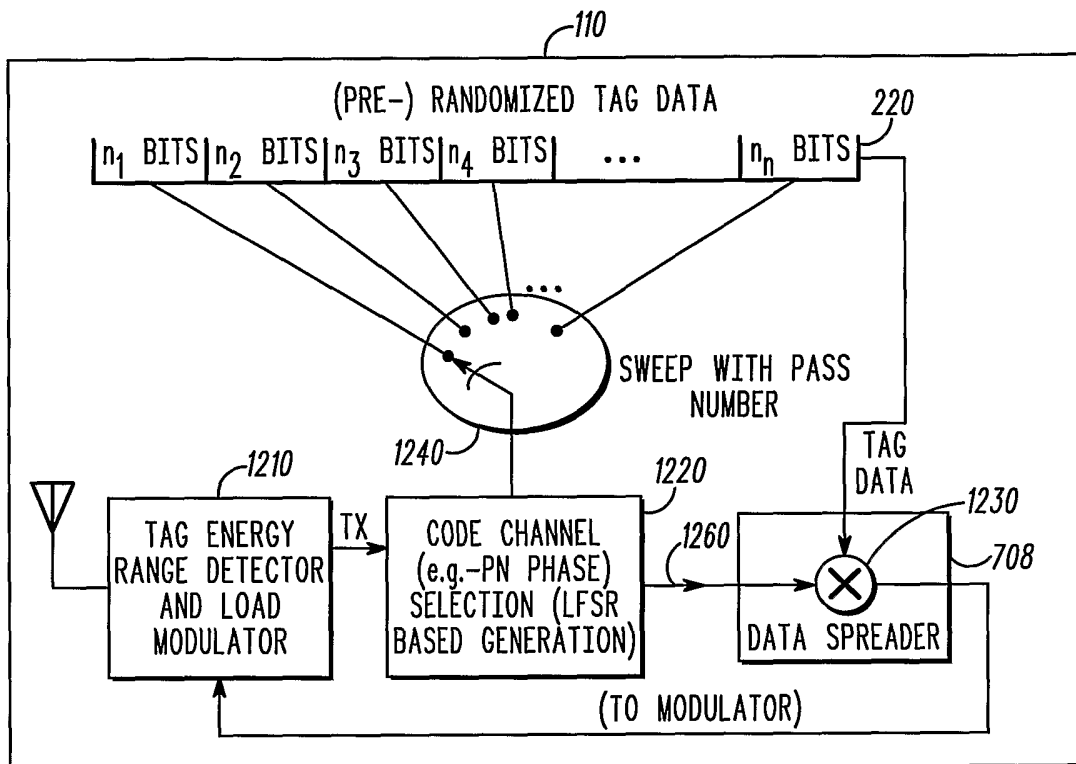

FIG. 12

11/20

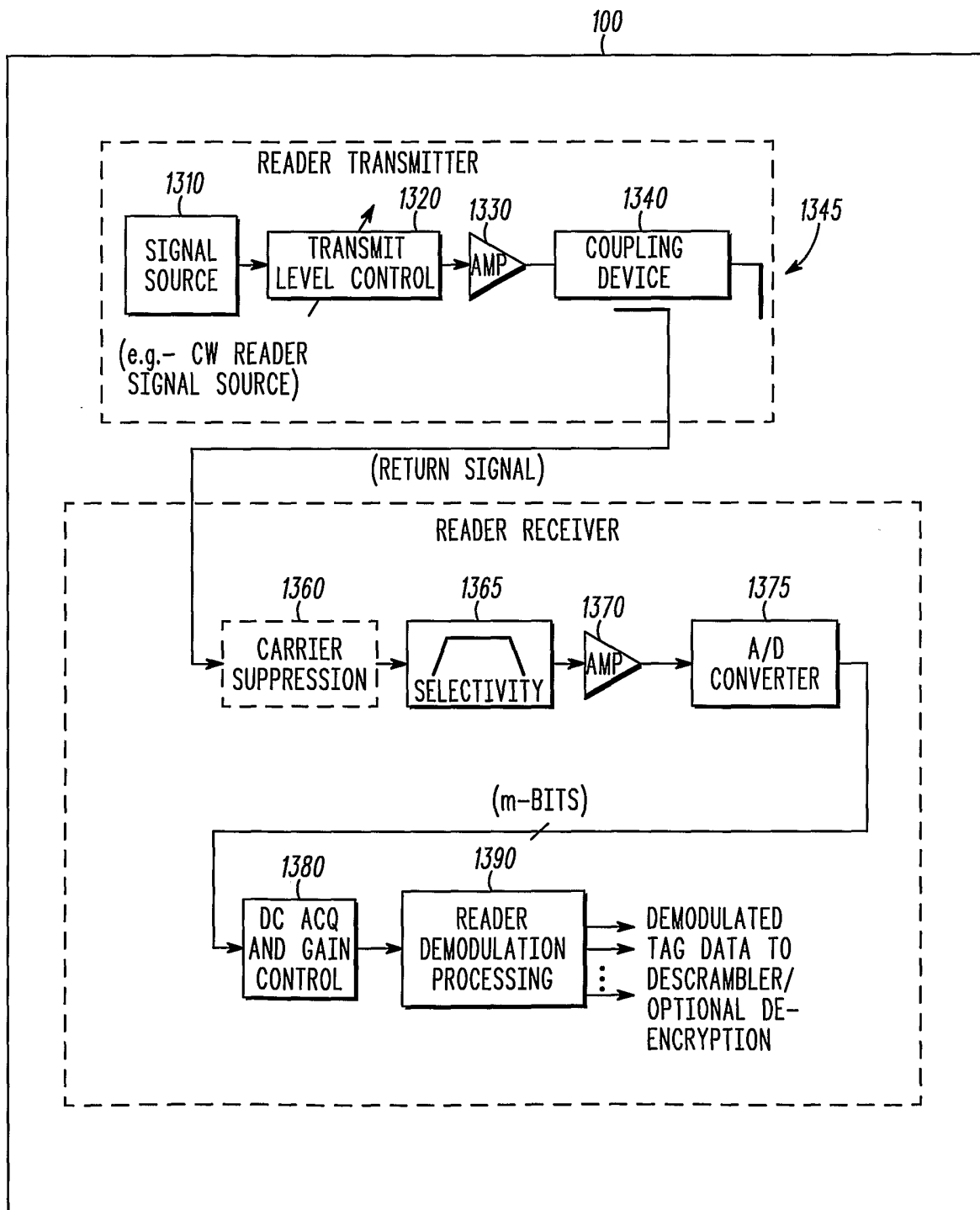
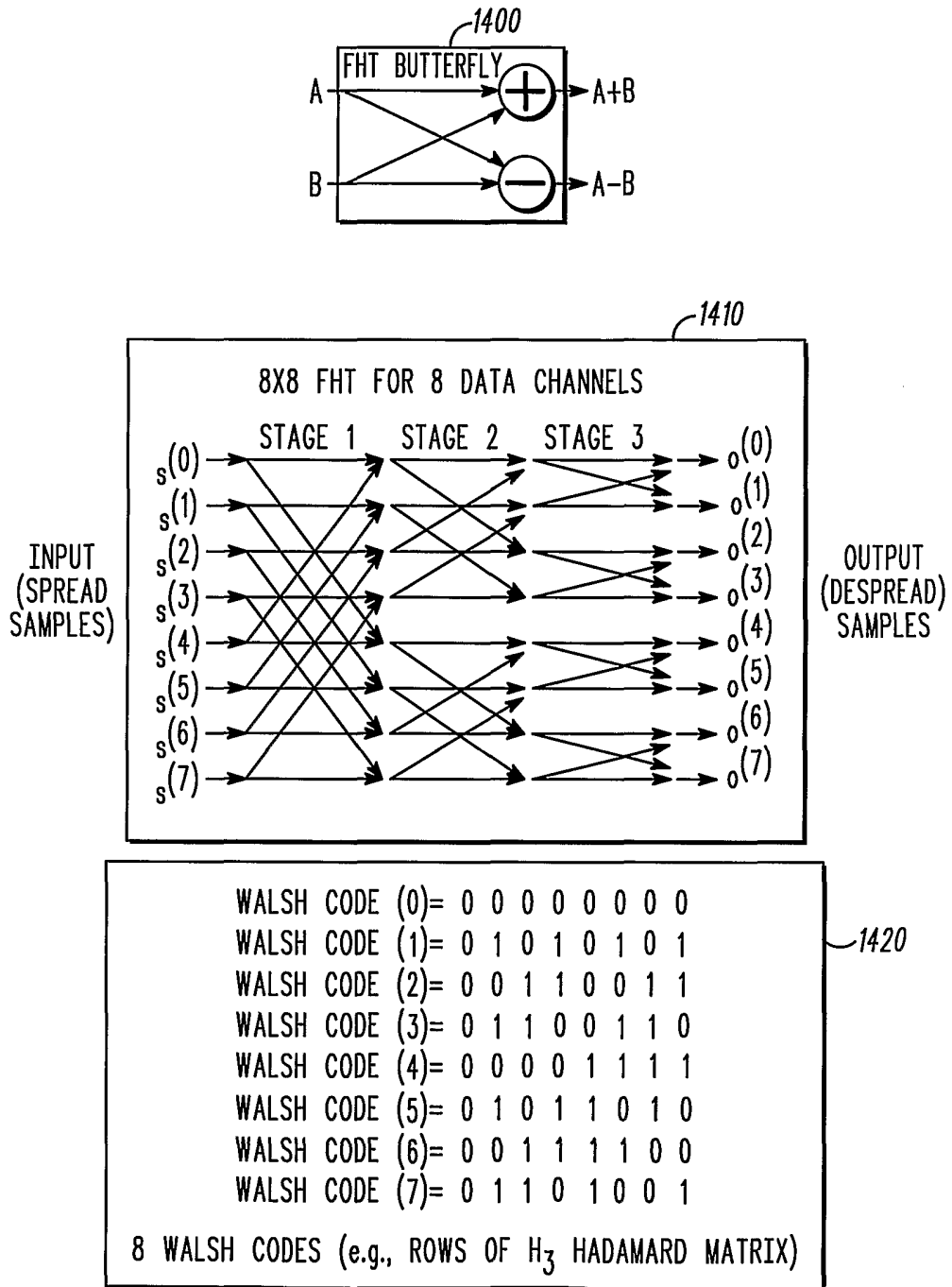

FIG. 13

12/20



$$(H_{n+1} = \begin{bmatrix} H_n & H_n \\ H_n & \overline{H_n} \end{bmatrix}, H_0 = 0)$$

FIG. 14

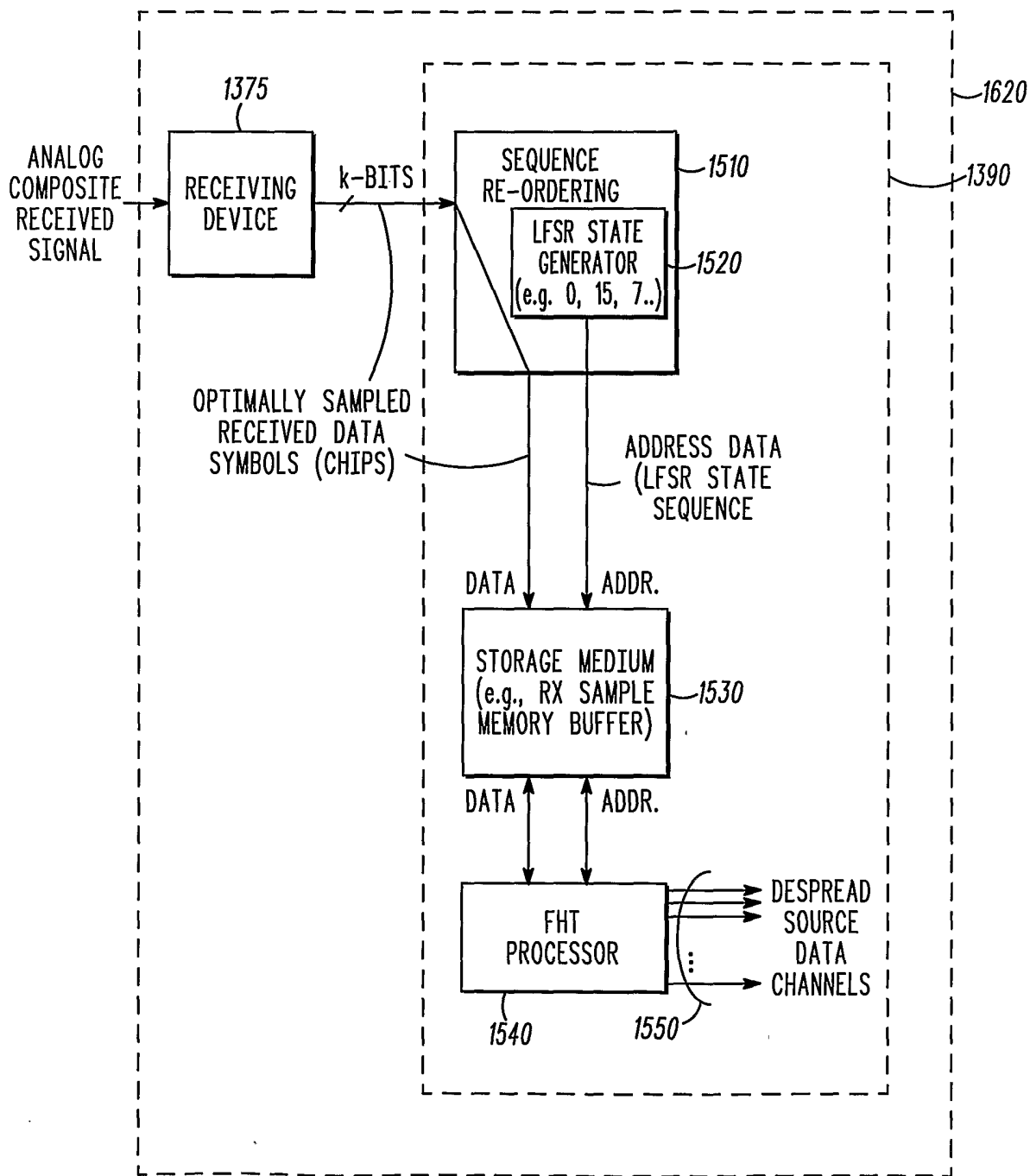

FIG. 15

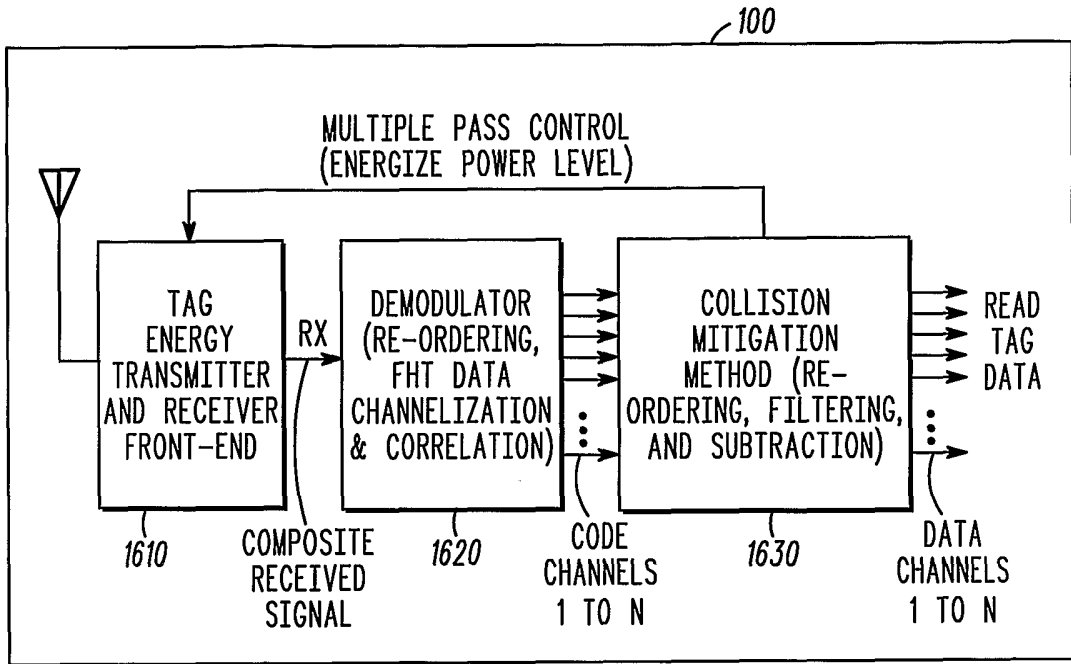
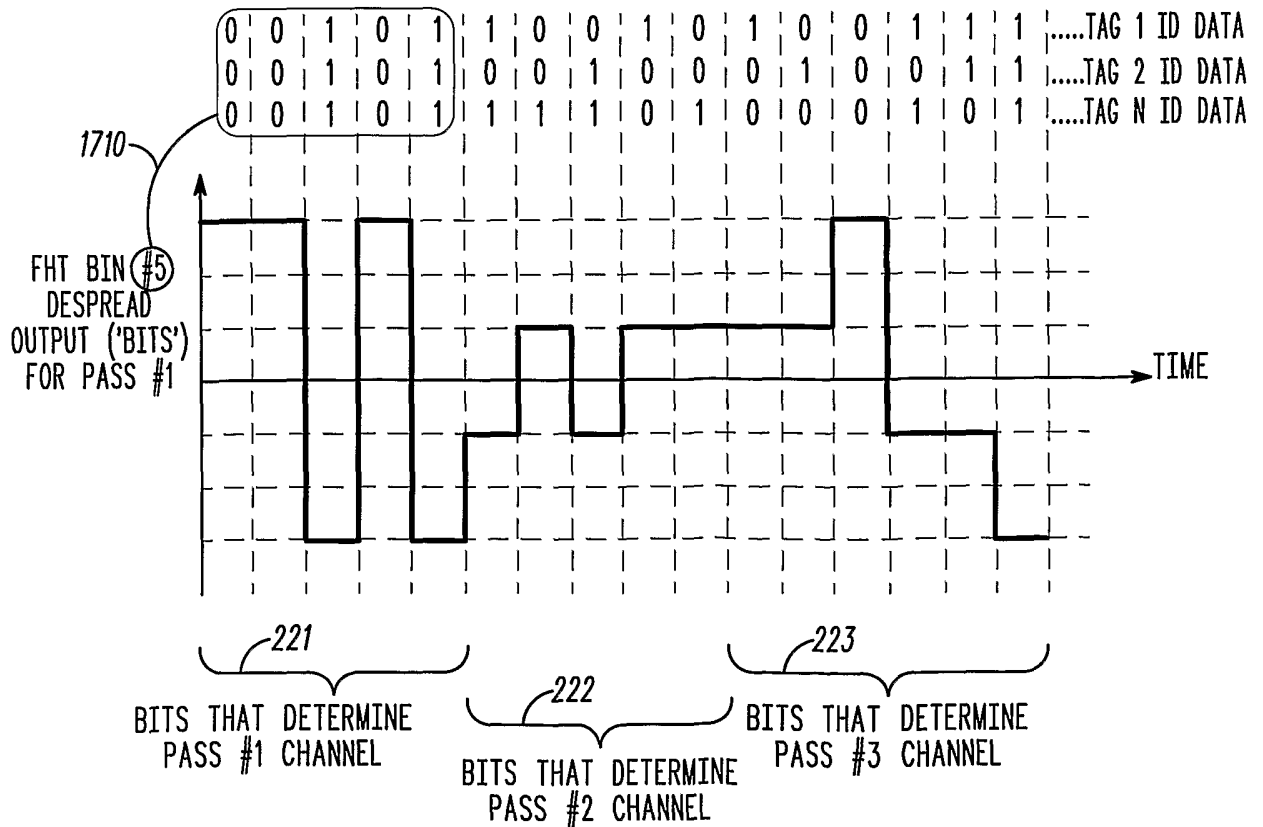

FIG. 16

FIG. 17



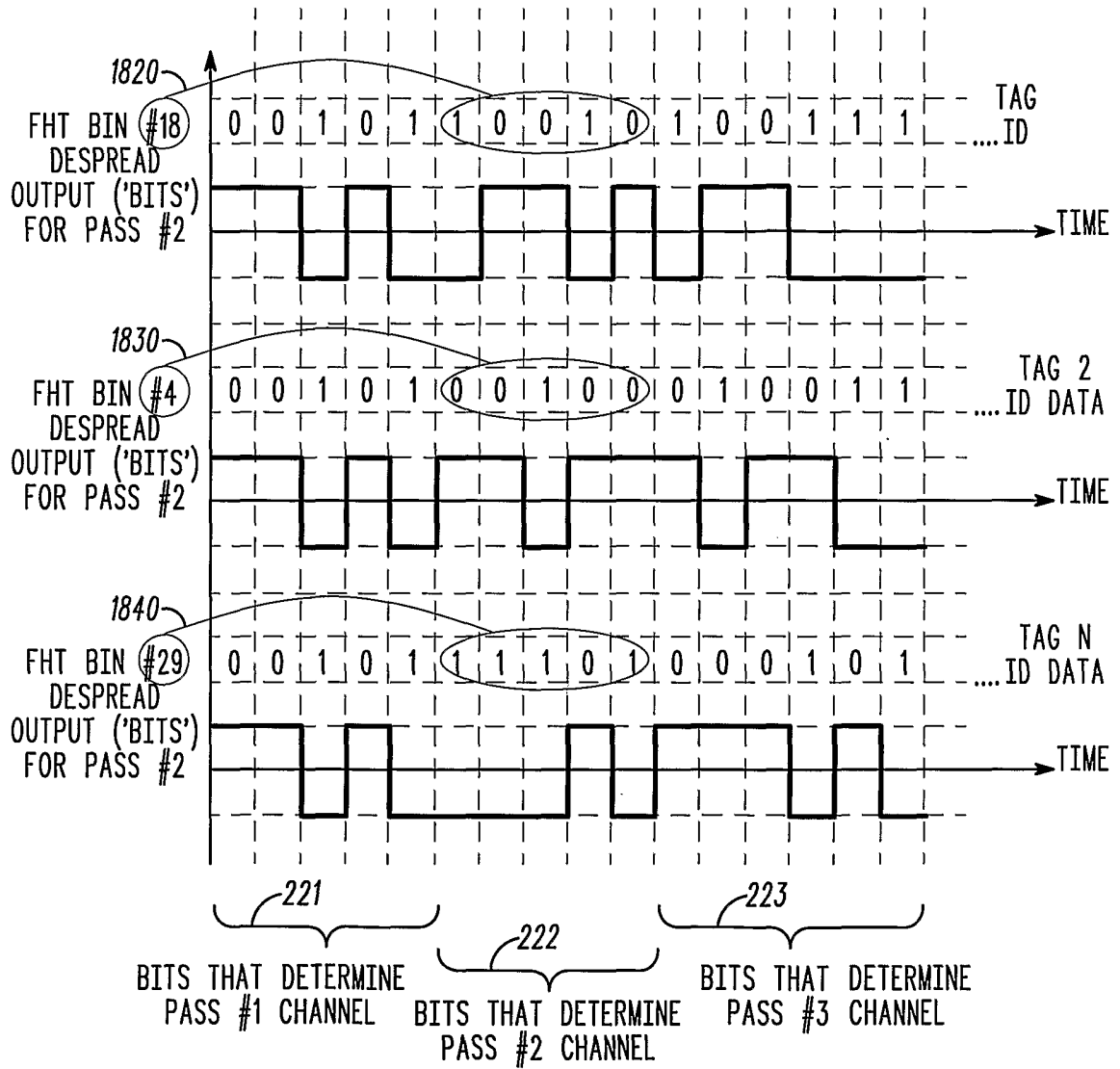

FIG. 18

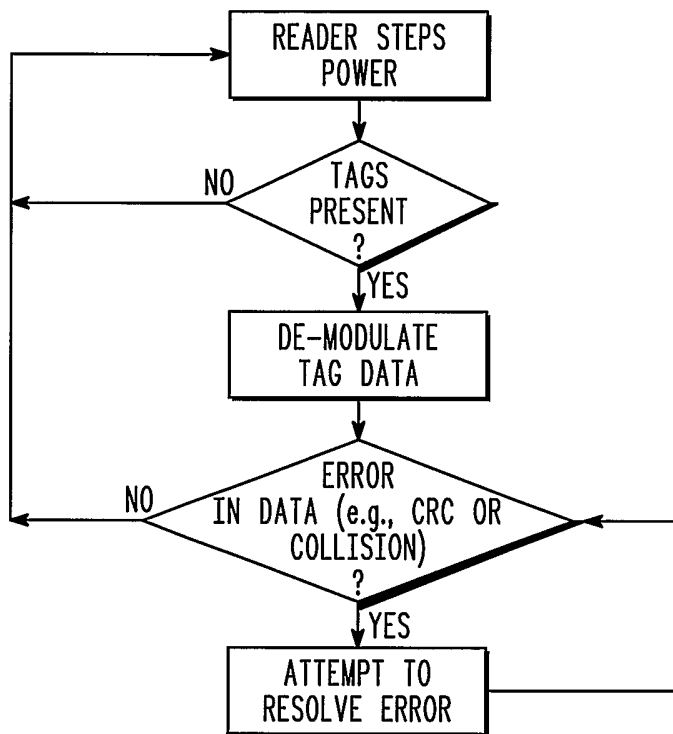

FIG. 19

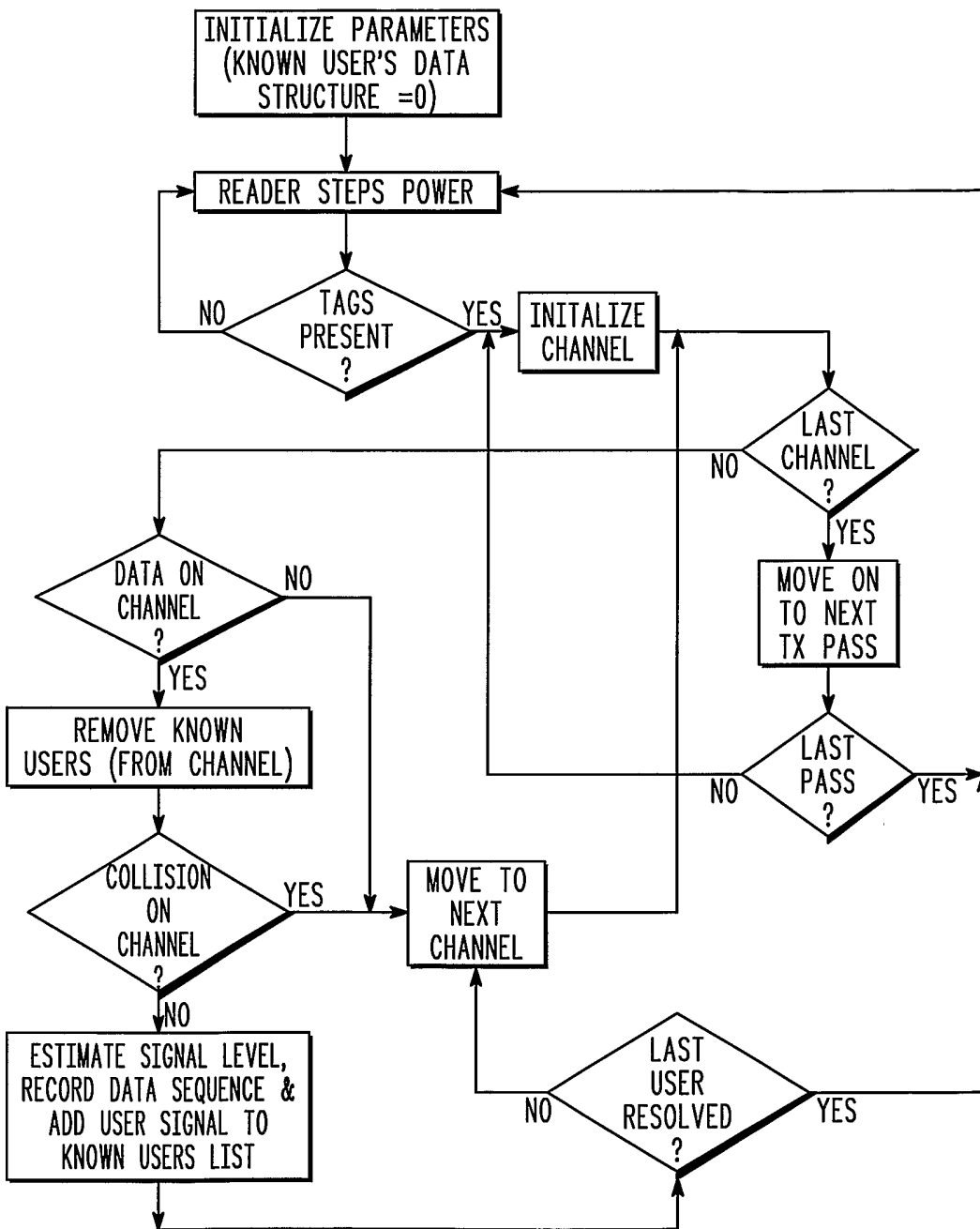

FIG. 20

18/20

CHANNEL NUMBER	#0	#1	#2	#3	#4	#5	#6	#7
PASS #1	①	2 6	4 8		③	⑦	⑤	
PASS #2	① 4 5	2 8			6 7			③
PASS #3	②			① 8	4 7		③	⑤ 6
PASS #4			⑤	7	④	⑧	① 2 6	③
PASS #5	①		2	⑤ 7	③	6 8	4	
PASS #6		4 8		⑤	① 3 6	2	7	
PASS #7		③ 4 8		① 6		2 5		7
PASS #8		2 4	⑥			⑤ 7 8	① 3	

LEGEND: CIRCLED ITEMS ARE NEWLY ID'd
 SHADED ITEMS ARE PREVIOUSLY ID'd

FIG. 21

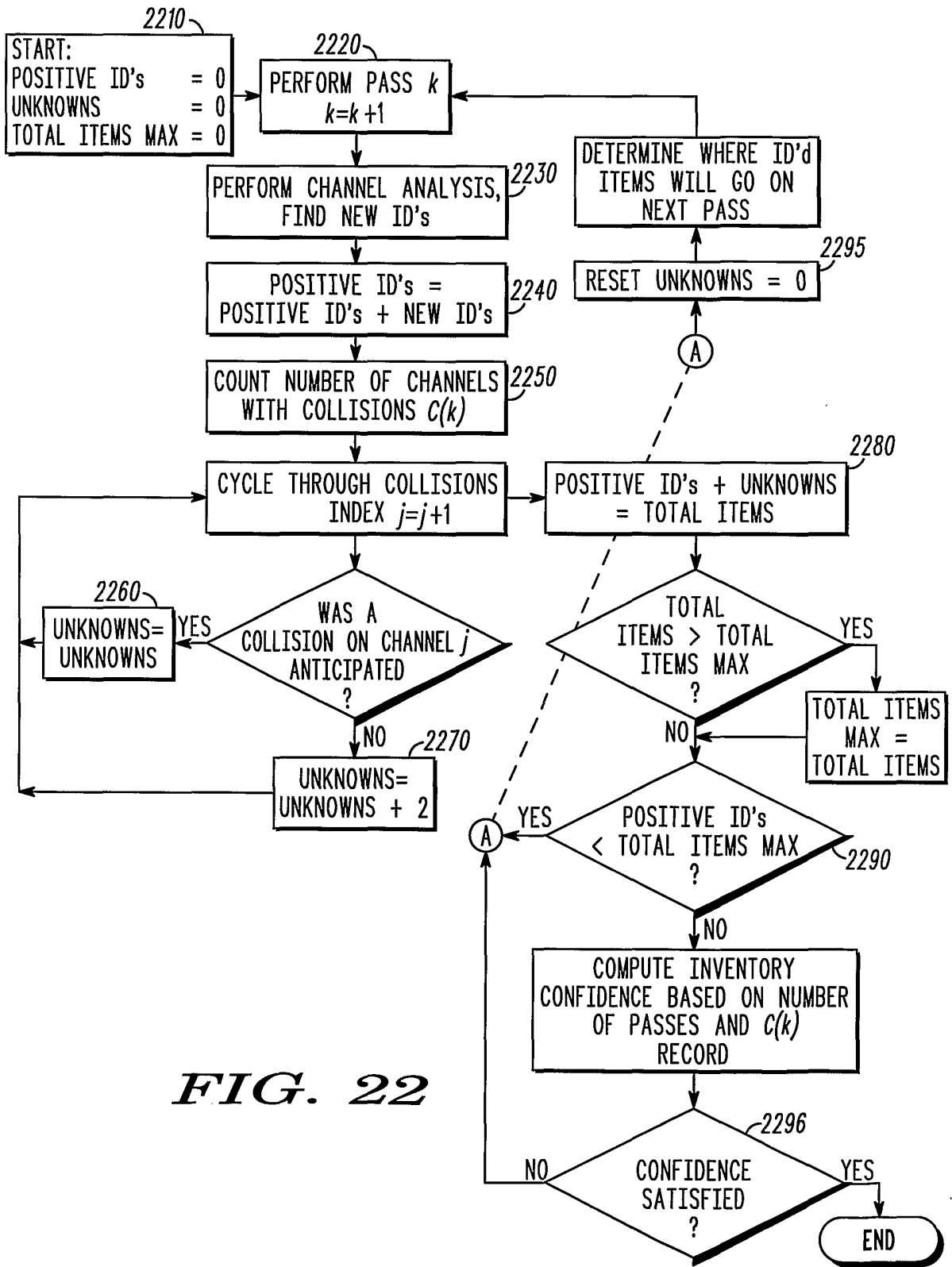

FIG. 22

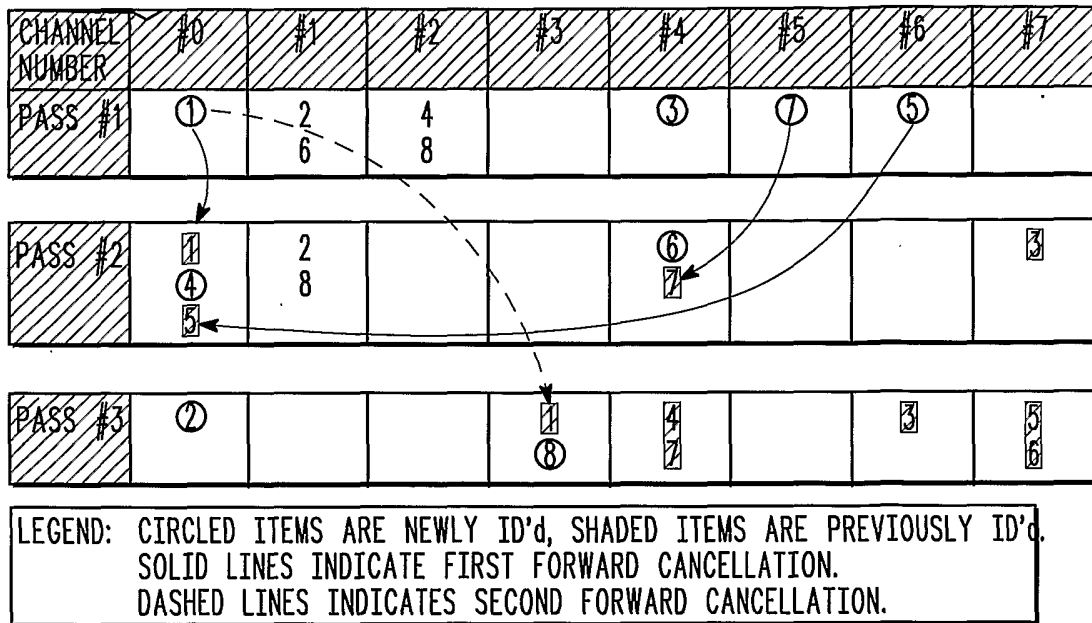

FIG. 23

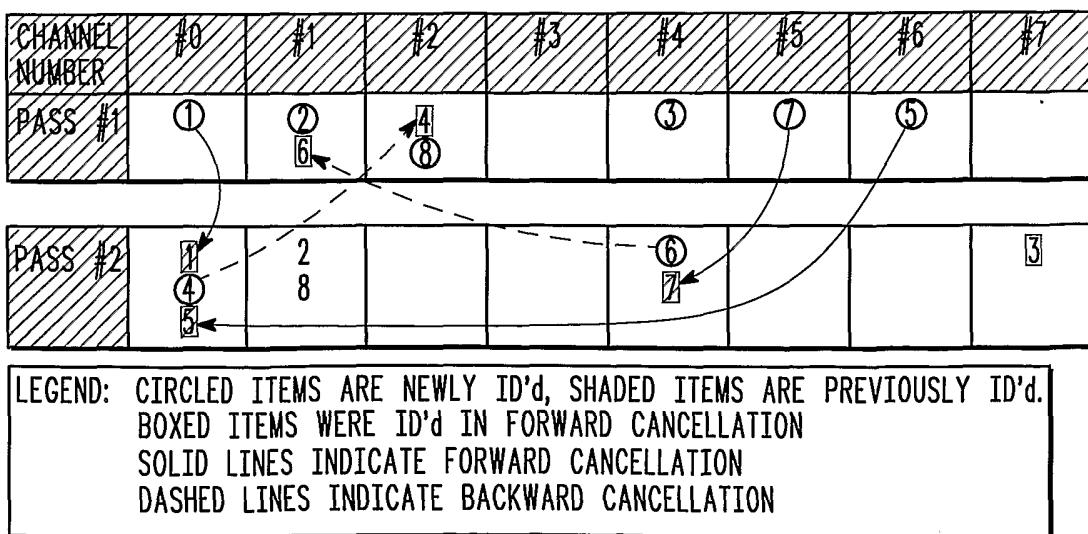

FIG. 24