

[54] **ALUMINUM-IRON COMPOSITE ROTOR HOUSING FOR A ROTARY COMBUSTION ENGINE AND METHOD OF MAKING THE SAME**

3,797,101 3/1974 Bauer..... 29/527.3

Primary Examiner—John J. Vrablik
Attorney, Agent, or Firm—George A. Grove

[75] Inventor: Carl A. Bierlein, Kettering, Ohio

[73] Assignee: General Motors Corporation, Detroit, Mich.

[22] Filed: May 30, 1974

[21] Appl. No.: 474,515

[52] U.S. Cl. 418/178; 418/179; 29/156.4 WL; 29/527.3

[51] Int. Cl.²..... F01C 21/00; B23P 15/00; B22D 19/00

[58] Field of Search..... 418/178, 179; 29/156.4 R, 29/156.4 WL, 149.5 DP, 149.5 PM, 527.3

[56] **References Cited**

UNITED STATES PATENTS

2,198,240	4/1940	Boegehold	29/149.5 PM
2,241,095	5/1941	Marvin	29/149.5 PM
3,155,313	11/1964	Bentele	418/178
3,359,615	12/1967	Bauer.....	418/178
3,553,806	1/1971	Turk et al.	29/149.5 PM
3,705,818	12/1972	Grosseau	418/178

[57] **ABSTRACT**

An aluminum rotor housing, having a chromium plated steel liner inner surface, is formed in a preferred embodiment hereof by first providing a thin steel strip with a thin, porous layer of copper and nickel powder metallurgically bonded to one surface. The strip is then shaped to define the generally epitrochoidal inner surface of the housing of a Wankel type rotary engine with the ends of the strip welded together and the porous layer on the outside. The shaped strip then is positioned on a core member in a die casting machine and a suitable aluminum alloy is cast into and over the porous layer bonded to the steel strip, thereby infiltrating the porous layer and forming a main body portion of the housing mechanically bonded to a steel liner portion. A coating of chromium may then be electroplated or otherwise applied to the steel liner to provide a hard, strong wear surface in the operation of a rotary combustion engine.

5 Claims, 4 Drawing Figures

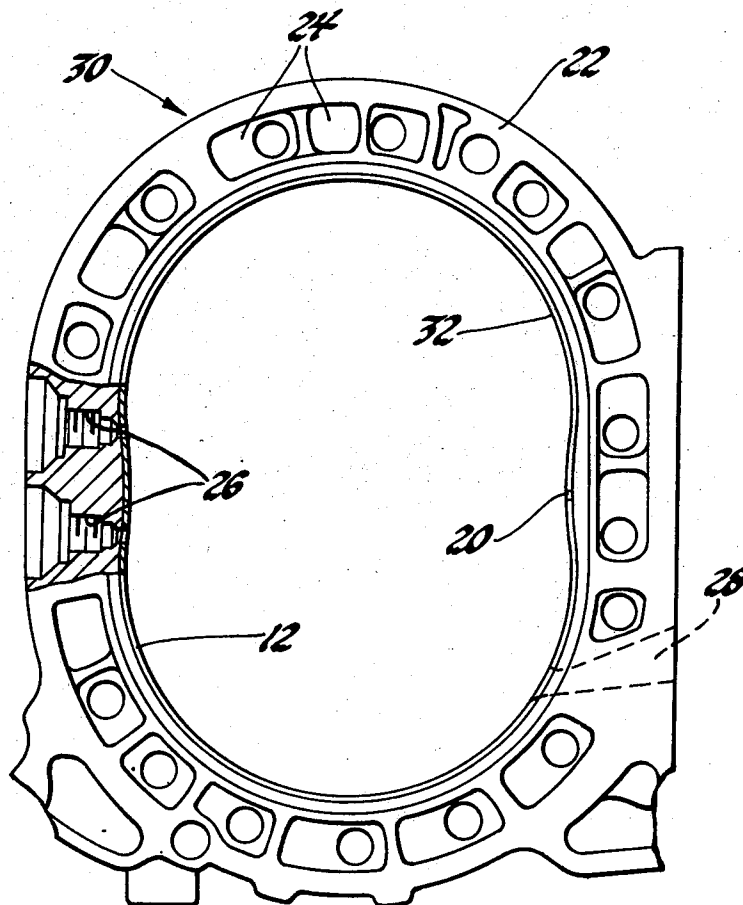

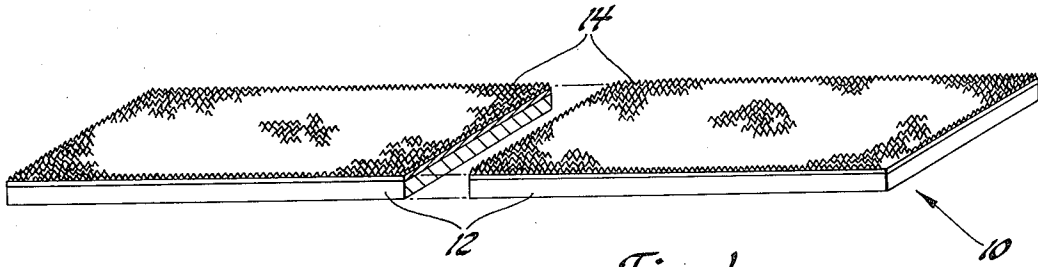

Fig. 1

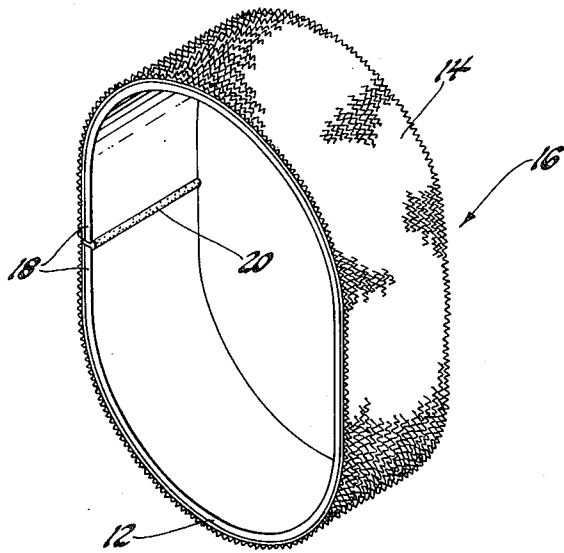

Fig. 2

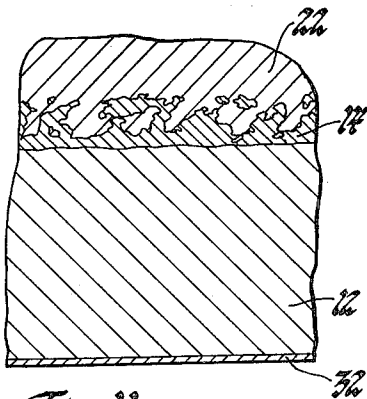

Fig. 4

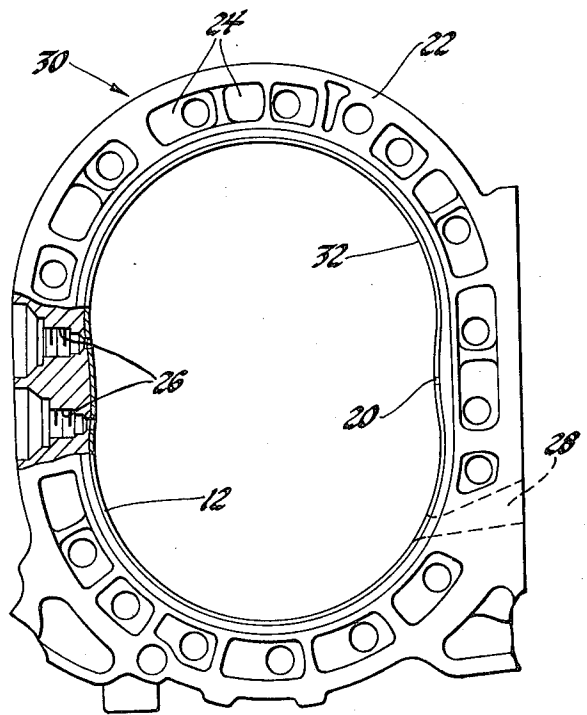

Fig. 3

ALUMINUM-IRON COMPOSITE ROTOR HOUSING FOR A ROTARY COMBUSTION ENGINE AND METHOD OF MAKING THE SAME

This invention pertains to the rotor housing member of a rotary combustion engine and to a method of making a rotor housing of the type having an aluminum body portion and a hard chromium wear surface, the chromium wear surface being bonded to the aluminum through a steel or other ferrous metal interlayer. More specifically, the subject invention relates to a low cost method of forming an aluminum rotor housing of a Wankel rotary engine having a chromium coated steel liner wherein there is a strong mechanical bond between the aluminum and the steel layer, which also provides good heat transfer from the interior of the engine out through the water-cooled aluminum rotor housing.

A known method of making aluminum-ferrous metal-chromium rotor housings for rotary combustion engines, particularly of Wankel type engines, is by the "transplant" technique. In this technique a mandrel defining the general configuration of the inner surface of the housing is prepared and preheated to about 400° F. A molten steel composition is sprayed on the surface of the mandrel to form a rough coating. The spray-coated mandrel is then preheated to 400° F., inserted in a die casting machine, and molten aluminum is die cast against the porous, rough steel layer to form the body portion of the housing. The cast aluminum adheres to the porous, rough iron surface. After the casting has been trimmed, the mandrel is chilled and the aluminum portion heated so that the mandrel can be pressed out of and separated from the die casting including the iron portion. Subsequently, the iron layer is ground or otherwise machined to a predetermined dimension. It is then provided with a hard chromium wear surface by electroplating or by metal spraying. It is the hard chromium surface that is engaged and worn by the apex seals on the rotor of the engine.

The transplant method of forming rotor housings is fairly expensive. Typically, it is necessary to replace mandrels after 400 to 500 parts have been formed. The metal spraying operation is a relatively difficult process, particularly in a die casting plant. Furthermore, it is desired to obtain a better bond between the ferrous and aluminum portions as regards strength and heat transfer than is obtained by die casting against the porous, rough, sprayed-on surface.

It is an object of the present invention to provide an aluminum-ferrous metal composite rotor housing for a rotary combustion engine wherein there is a tenacious interlocking bond between a steel liner member and a die cast aluminum body through an initially porous layer of copper and nickel powders, or copper and iron powders.

It is also an object of this invention to provide a method of economically forming such a housing.

It is another object of the present invention to provide a method of forming an aluminum rotary engine housing of a Wankel type engine, the housing having a chromium coated steel liner on the inner surface of an aluminum body member by starting with steel strip and affixing thereto a porous sintered layer of nickel powder and copper powder, or iron powder and copper powder, and thereafter die casting aluminum alloy into and over this porous layer on the steel strip to form the body portion of the housing. In the die casting operation the aluminum permeates the porous layer, forming

a tenacious and highly efficient mechanical bond for thermal conductivity therewith.

In accordance with a preferred embodiment of my invention, these and other objects are accomplished by first depositing a thin layer of loose, thoroughly mixed copper and nickel (or iron) powder particles on a carbon steel strip, the steel containing about 0.08% to 0.8% by weight carbon depending upon the ultimate hardness desired. The steel strip is suitably of indefinite length and continuously drawn through a sintering oven containing a dry exothermic atmosphere at about 2,050° F. In the hot furnace the copper particles melt and coat and alloy with the nickel particles, bonding them tightly to each other and to the steel strip in a porous, sponge-like layer. Upon cooling, the strip with an adherent, sponge-like surface layer is cut to a predetermined length equivalent to the circumferential dimension of the inner surface of the desired rotary engine housing member. If necessary, the strip is also slit to a width approximately equal to the width of the housing member.

The strip is then bent and shaped in a closed loop to generally define the inner surface of the housing member with the porous sintered layer on the outer surface and the ends of the strip abutting. The abutting ends are butt welded. The shaped strip is then slipped over a suitable mandrel or core member for a die casting operation. Molten aluminum alloy is then die cast against the strip so that it permeates the porous sponge layer and forms the body portion of the housing member. At this stage the die cast housing body may be characterized as being made up of an aluminum body portion bonded to a steel inner liner surface through an aluminum infiltrated layer of copper-brazed nickel (or iron) particles. The inner surface of the steel liner may then be ground or otherwise machined to a predetermined dimension and then provided with a hard chromium wear surface by any suitable method.

Other objects and advantages of the invention will become more apparent from a detailed description thereof which follows, in which reference will be made to the figures of the drawing.

FIG. 1 is a perspective view of a section of steel strip having applied to the upper surface thereof a porous, sponge-like layer of brazed metal particles.

FIG. 2 is a perspective view of the strip cut to length and shaped in a closed loop generally in the configuration of the internal surface of the housing with the porous layer on the outside of this formed member.

FIG. 3 depicts the housing member after casting formed of an aluminum die cast body portion bonded to the steel liner inner surface.

FIG. 4 is an enlarged portion of a section of the housing member showing schematically the nature of the bond between the aluminum body portion and the steel liner.

In the manufacture of an aluminum rotary engine rotor housing member having a ferrous metal inner liner, an improved bond between the ferrous metal portion and the aluminum can be formed by starting out with a ferrous metal strip and applying and affixing thereto a thin, sponge-like layer of brazed powdered metal. Preferably, the strip is made of a hardenable carbon steel, such as SAE 1070 steel. However, other iron base compositions may be employed depending upon the hardness and strength requirements of the housing in a particular engine. The ferrous material serves as a surface to which an adherent chromium layer can be

applied and adds strength to the predominantly aluminum housing. In accordance with a preferred embodiment of this invention, the minimum strip thickness should be enough so that it can be self-supporting when drawn through a sintering furnace at 2000° to 2100° F. Thicker, higher strength strip can be used when the strength requirements of the housing dictate. In general, it is preferred that the strip be about 1.40 millimeters in thickness or greater. The width of the strip should be equal to or larger than the width of the inner surface of the rotary engine housing to be formed. The strip can be of indefinite length but is preferably longer than the inside circumferential dimension of the housing member to be formed plus a weld allowance. In general, it will be desirable in the practice of this invention to start with a coil of steel strip stock and unwind the coil and process it in a continuous fashion, cutting off suitable lengths from the process strip at an appropriate time in the process, as will be described. The steel should be free of scale, degreased and otherwise clean so that powdered metal may be bonded thereto.

The spongy layer is formed starting with a suitable mixture of metal powders. Preferably, copper powder is used in combination with nickel powder and/or iron powder as these specific metal combinations have been found to contribute to a very strong bond between the aluminum and steel in the cast product. Fifty-five to 85 parts copper powder are employed in combination with 45 to 15 parts of the nickel and/or iron powder. The size of the respective metal powders is of some importance in obtaining a suitable porous layer. Preferably, the copper powder is of finer grain size than the iron or nickel so that the copper powder can readily fill voids between close lying iron or nickel particles and ultimately thoroughly wet and alloy with the iron or nickel when a sintering or brazing temperature is reached. For example, excellent results have been obtained using nickel and/or iron powder which passes an 80 mesh screen and is held on a 100 mesh screen, thoroughly mixed with copper powder which passes a 100 mesh screen and is held on a 200 mesh screen.

In accordance with a preferred embodiment of my invention, a mixture of 85 parts copper powder of the above defined grain size and 15 parts nickel powder, also of the above defined grain size, are thoroughly blended. This mixture is deposited on a strip of SAE 1008-1010 or higher carbon steel, 1.5 millimeters in thickness and 75 to 80 millimeters wide. The powder mixture is deposited on the horizontally disposed strip as a loose powder and scraped to a depth of about 1 millimeter. This loose powder thickness has been found to yield a finish sponge layer thickness of 0.33 millimeter to 0.46 millimeter after sintering.

The steel strip carrying the loose powder mixture is then drawn into a furnace containing a dry exothermic atmosphere and maintained at a temperature of about 2050° F. An example of a suitable atmosphere is one nominally made up, by volume, of 6% CO₂, 8% CO, 8% H₂ and 78% N₂ and having a dew point no higher than 58° F. The strip is continuously drawn through the furnace with the residence time of any element thereof being about 15 minutes. When the strip is in the hot furnace the copper particles melt and flow to wet and alloy with the nickel powder. The nickel particles soften, but do not melt, and they retain their general form while they are metallurgically bonded to each other and to the steel strip by the copper upon solidification. As the strip emerges from the furnace and is

cooled, it has the appearance of the composite strip 10 depicted in FIG. 1. The carbon steel strip portion is indicated at 12 and the porous, spongy layer of nickel particles bonded together with copper is indicated at 14. The steel strip may be hardened.

As indicated, at this stage of the process the sponge coated strip 10 may be of any desired length and width. The strip may now be suitably slit to a width equal to or slightly greater than the width of a housing member to be produced. The slightly greater width may be preferred in some cases to facilitate a die casting operation as will be described below. The strip may also be coiled for shipping to another processing plant or it may be cut into suitable lengths substantially equivalent to the circumferential dimension of the internal surface of a housing member to be produced.

In accordance with a preferred embodiment of my invention, the composite strip 10 is slit to a width of about 76 millimeters. It is straightened and cut to lengths of 851 millimeters. The strip is then bent into a generally circular but oblong configuration to form a preformed inner liner member (indicated at 16 in FIG. 2) for a rotor housing member of a Wankel engine with the nickel sponge layer 14 being on the outside. The ends 18 of the strip are brought into an abutting relationship (as indicated in FIG. 2) and butt welded together, the weld metal being indicated at 20. Two opposite portions of the strip are slightly flattened as shown in FIG. 2, preferably over a distance of about 2 inches, to accommodate welding and a subsequent grinding or sciving operation to remove the weld metal penetrating into the internal portion of the preformed liner.

The preformed liner 16 is then further shaped, principally by slightly bending in the flat portions of the preformed liner into the well known Wankel epitrochoidal form. The liner may be preheated to about 300° to 400° F. and fitted over a permanent mandrel or core member for insertion into the die chamber of a die casting machine. At this stage the strip may be slightly wider than the housing member to be produced so that the strip can be fitted into grooves in die members of the casting machine for better support of the strip in a die casting operation.

In accordance with conventional die casting practice, molten aluminum alloy, such as, e.g. commercial alloy No. 380, at about 1350° F. is then forced into the die cavity under considerable pressure to form the body of the rotor housing member. The molten aluminum under pressure readily permeates the interstices of the sponge layer 14 of the liner 16 (see FIG. 4). Upon solidification of the molten aluminum the body portion 22 (FIGS. 3 and 4) of the composite rotor housing 30 is formed and aluminum is interlocked with the sponge layer and thus tightly bonded to the steel liner member.

The rotor housing, as is known, is a fairly complex structure having suitable passages 24 for engine coolant, openings for spark plugs 26 and typically one or more exhaust outlets 28. In a fully assembled engine (not shown) the rotor housing cooperates with side housing members in a known manner to define a cavity in which an eccentrically mounted, generally triangular working rotor rotates and orbits. Apex seals on the rotor engage the internal surface of the housing to define three fluid spaces of variable volume as the rotor piston rotates.

In FIG. 3, the steel liner 12 is clearly perceptible in the cast housing, the welded portion being indicated at

20. It is preferred that this welded joint be located at the relatively low temperature side of the housing (referring to conditions during engine operation) opposite the spark plug location. The original porous layer of the preform can no longer be seen as such because it is filled with aluminum. However, typically in a rotor housing 30 produced by this method a copper hue can still be seen immediately behind the steel liner layer 12 even though the sponge portion is filled with aluminum.

Following the die casting operation, the inner surface of the housing member is ground to a suitable predetermined dimension and a thin, hard chromium layer 32 (location only indicated in FIG. 3) is then applied to the steel inner surface by electroplating or other suitable means. The chromium layer is usually only about 0.15 millimeter in thickness.

Photomicrographs of sections of composite rotor housing members prepared in accordance with the invention show excellent aluminum alloy penetration of the copper-nickel sponge layer as well as a metallurgical bond between the copper-nickel sponge layer and the steel sheet liner. By comparison, photomicrographs taken of similar sections prepared from liners manufactured by the prior art transplant process show large amounts of entrained air and slag and a rough but not back-drafted interface line with the aluminum. The fact that in accordance with this invention the aluminum alloy penetrates into the sponge layer produces a significant increase in the tensile strength of the bond between the aluminum and steel liner as well as in the coefficient of thermal conductivity between the steel liner and the aluminum body portion. For example, a typical interfacial tensile strength of the bond of aluminum to a sprayed iron liner (transplant process) has been found to be about 4,800 pounds per square inch whereas the tensile strength of the bond between the aluminum and the sheet metal liner produced in accordance with my invention has been found to be 7,250 pounds per square inch. Moreover, a housing prepared in accordance with my process offers only about 70% of the thermal resistivity in a radially outward direction of a liner of the same dimensions prepared in accordance with the prior art transplant process. It has also been found that in the practice of the subject process the mandrel used in the die casting operation has had a useful life of some 2,000 pieces as compared with a mandrel life in the transplant process of 400-500 pieces.

While my invention has been described in terms of a few specific preferred embodiments thereof, it will be appreciated that other forms could readily be adapted by one skilled in the art. Accordingly, the scope of my invention is to be considered limited only by the following claims:

What is claimed is:

1. A composite rotor housing member for a rotary engine of the type characterized by a rotor housing defining a closed peripheral surface, a side housing member on each side of said rotor housing, said rotor housing and side housing members cooperating to define a cavity in which a rotary piston is rotatably mounted in sealing engagement with said peripheral surface, a said rotor housing member comprising:

an aluminum or aluminum alloy die cast body portion having a ferrous metal liner on the inner surface of said body portion, said liner defining the configuration of a said peripheral surface of a said rotor cavity, and an intermediate sponge-like layer of cop-

per brazed metal particles fused to each other and to said ferrous metal liner, said metal being selected from the group consisting of iron and nickel, the aluminum body portion penetrating pores between particles of said intermediate layer in a strong coextensive interlocking mechanical and heat conductive bond with said ferrous metal liner.

2. A composite rotor housing member for a rotary engine of the type characterized by a rotor housing defining a closed peripheral surface, a side housing member on each side of said rotor housing, said rotor housing and side housing members cooperating to define a cavity in which a rotary piston is rotatably mounted in sealing engagement with said peripheral surface, a said rotor housing member comprising:

an aluminum or aluminum alloy die cast body portion having a carbon steel liner on the inner surface of said body portion, said liner defining the configuration of a said peripheral surface of a said rotor cavity, and an intermediate sponge-like layer of copper brazed metal particles fused to each other and to said steel liner, said metal being selected from the group consisting of iron and nickel, the aluminum body portion penetrating pores between particles of said intermediate layer in a strong coextensive interlocking mechanical and heat conductive bond with said steel liner.

3. A method of forming a composite rotor housing member for a rotary engine comprising:

providing a ferrous metal strip,
depositing a loose but uniformly mixed powder composition comprising copper and a material taken from the group consisting of iron and nickel in a thin layer on a surface of said strip,
heating said powder mixture to fuse the copper portion thereof and bond the other metal particles to each other and to said strip in an adherent porous sponge layer,
cutting said strip, if necessary, to a desired predetermined length and shaping it to define the closed inner surface portion of a said housing member, the ends of said strip then being in abutting relationship and said sintered layer being on the outside surface of said strip,
joining the abutting ends of said strip, and
die casting aluminum metal around the shaped ferrous metal strip member to form the body portion of a said housing member on said ferrous strip member, molten aluminum permeating said porous sponge layer to form upon solidification a strong bond with said ferrous metal strip liner.

4. A method of forming a composite rotor housing member for a rotary engine comprising:

providing a carbon steel strip,
depositing a loose but uniformly mixed powder composition comprising, by weight, 55 to 85 parts copper and 45 to 15 parts of a material taken from the group consisting of iron and nickel in a thin layer on a surface of said strip,
heating said powder mixture to fuse the copper portion thereof and bond the other metal particles to each other and to said strip in an adherent porous sponge layer,
cutting said strip, if necessary, to a desired predetermined length and shaping it to define the closed inner surface portion of a said housing member, the ends of said strip then being in abutting relationship and said sintered layer being on the outside

7

surface of said strip, joining the abutting ends of said strip, and die casting aluminum metal around the shaped carbon steel strip member to form the body portion of a said housing member on said steel strip member, molten aluminum permeating said porous sponge layer to form upon solidification a strong interlocking mechanical bond with said porous layer and thus with said steel liner.

5. A method of forming a composite rotor housing member for a rotary engine, the said engine being of the type in which a rotor housing cooperates with side housing members to define a cavity in which an eccentrically mounted working rotor rotates and orbits, the rotor housing having a relatively high temperature side during operation of said engine at which combustion takes place and a relatively low temperature side opposite said high temperature side, said method comprising:

depositing a loose but uniformly mixed powder composition comprising copper and a material taken

8

from the group consisting of iron and nickel in a thin layer on a ferrous metal strip, heating said powder mixture to fuse the copper portion thereof and bond the other metal particles to each other and to said strip in an adherent porous sponge layer,

cutting said strip, if necessary, to a desired predetermined length and shaping it to define the closed inner surface portion of a said housing member, the ends of said strip then being in abutting relationship and said sintered layer being on the outside surface of said strip, joining the abutting ends of said strip, and

die casting aluminum metal around the shaped ferrous metal strip member to form the body portion of a said housing member on said ferrous strip member, molten aluminum permeating said porous sponge layer to form upon solidification a strong bond with said ferrous metal strip liner, the joint in said strip being located at said low temperature side of said housing.

* * * * *

25

30

35

40

45

50

55

60

65