

A. P. CRISWELL.
APPARATUS FOR DRYING GRAINS.

(Application filed June 7, 1902.)

(No Model.)

2 Sheets—Sheet 1.

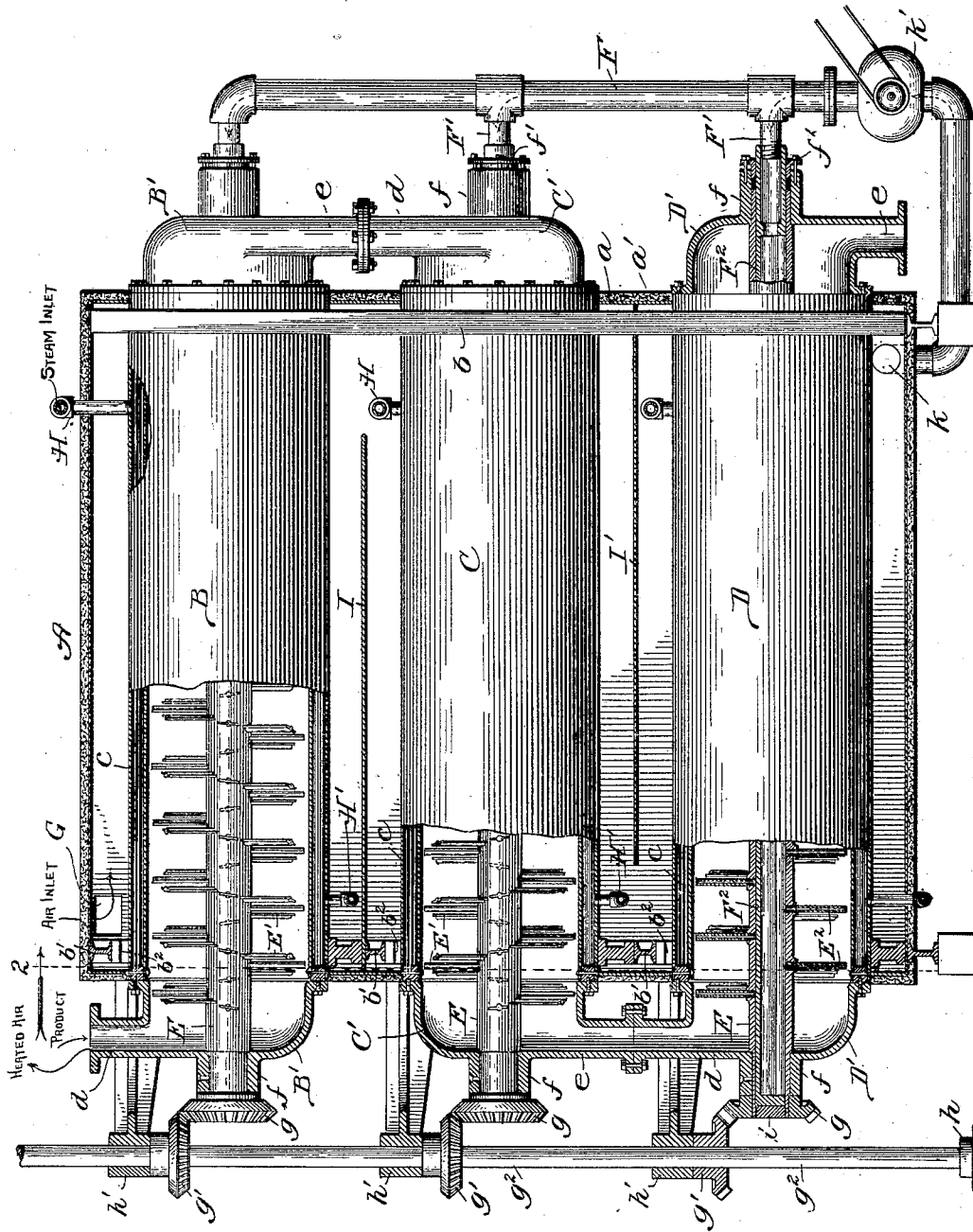

FIG. 1.

witnesses:
Edw. J. Gayles
John Enders Jr.

Inventor:
Alexander P. Criswell,
By Dymfourt, Dymfourt & Lee,
Att'ys.

No. 713,859.

Patented Nov. 18, 1902.

A. P. CRISWELL.
APPARATUS FOR DRYING GRAINS.

(Application filed June 7, 1902.)

(No Model.)

2 Sheets—Sheet 2.

Fig. 2.

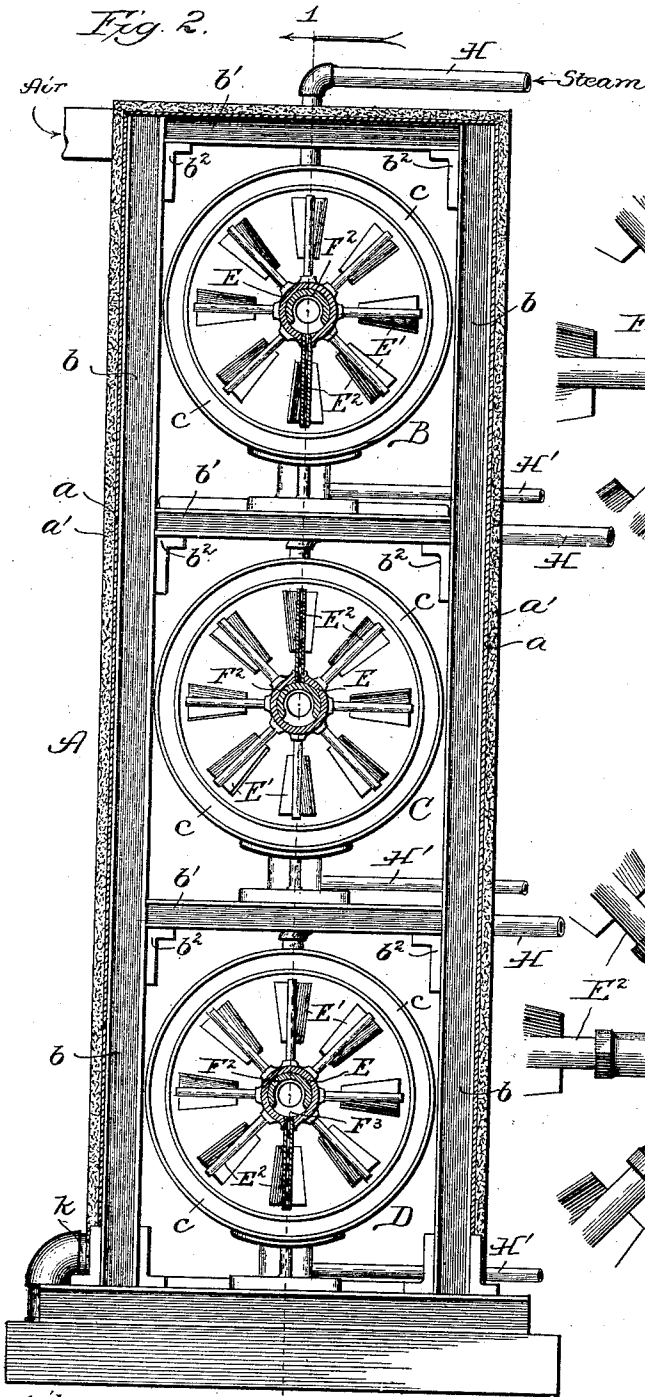

Fig. 3.

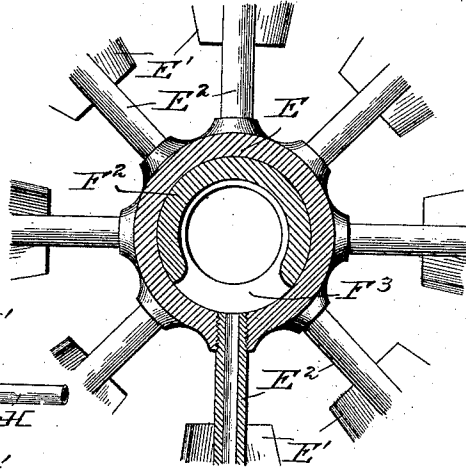
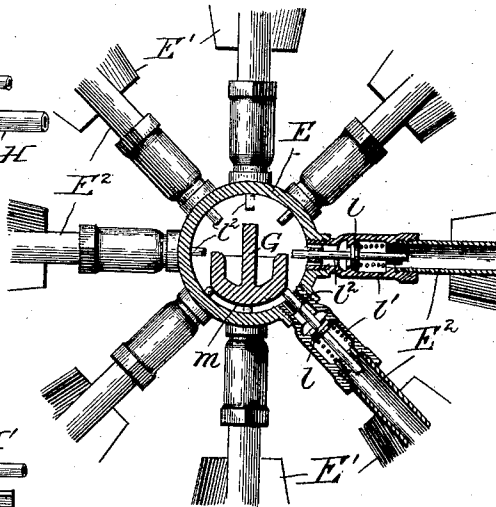

Fig. 4.



Witnesses:
Edw. P. Taylor.
John Enderes, Jr.

Inventor:
 Alexander P. Criswell,
 By *Dyrenforth, Dyrenforth & Lee,*
Att'ys.

UNITED STATES PATENT OFFICE.

ALEXANDER P. CRISWELL, OF CHICAGO, ILLINOIS, ASSIGNOR OF ONE-HALF TO JOHN M. WESTERLIN AND ALLAN CAMPBELL, OF THE FIRM OF WESTERLIN & CAMPBELL, OF CHICAGO, ILLINOIS.

APPARATUS FOR DRYING GRAINS.

SPECIFICATION forming part of Letters Patent No. 713,859, dated November 18, 1902.

Application filed June 7, 1902. Serial No. 110,616. (No model.)

To all whom it may concern:

Be it known that I, ALEXANDER P. CRISWELL, a citizen of the United States, residing at Chicago, in the county of Cook and State of Illinois, have invented new and useful Improvements in Apparatus for Drying Grains, of which the following is a specification.

My invention relates to improvements in drying apparatus for employment in distilleries or other establishments where grain or any other material is subjected in large quantities to a drying operation. In apparatus for this purpose as commonly constructed the material to be dried is fed into one end of a drying-chamber and automatically stirred and advanced while being subjected to the drying action of currents of air.

My object is to provide apparatus of this class of an improved construction which gives to the apparatus comparatively great capacity and renders it particularly effective for its purpose, as well as economical to construct and operate.

In the drawings, Figure 1 is a broken sectional elevation of apparatus constructed with my improvements, the section being taken on line 1 in Fig. 2 and viewed in the direction of the arrow; Fig. 2, an enlarged cross-section taken on line 2 in Fig. 1; Fig. 3, an enlarged broken sectional view of a rotary air-conducting pipe and branch pipes with one form of valve mechanism; Fig. 4, a similar view showing a modified form of the valve mechanism.

A is the outer casing of the apparatus, which is formed, preferably, of sheet or plate metal *a* and a heat-insulating lining or covering *a'*. The casing is upon a skeleton frame consisting of uprights *b b* and cross-bars *b' b'*, resting upon brackets *b²* on the uprights.

B, C, and D are longitudinally-extending cylinders or drying-chambers mounted one above the other in the frame and casing A, each being surrounded by a steam-jacket *c*. The cylinders B, C, and D are formed with the heads B' C' D' extending through the end walls of the casing A and provided with inlet and outlet pipe-sections *d e*, respectively. The inlet-pipe *d* of each cylinder, which is also an air-vent, extends upward, while the outlet *e* at the opposite end extends from the lower side thereof downward, and the outlet-

pipes of the two upper cylinders are bolted to the inlet-pipes of the next lower cylinders in each instance, whereby the said cylinders and pipes form a continuous convoluted passage from the inlet *d* of the uppermost cylinder to the outlet *e* of the lowermost cylinder.

E E E are rotary hollow shafts journaled at opposite ends in bearings *f* in the cylinder-heads. At one end the shafts are provided with beveled gear-wheels *g*, meshing with beveled gears *g'* on a vertical shaft *g²*, driven to rotate from any suitable source of power. The shaft *g²* rests at its lower end in a seat *h* and is steadied by brackets *h'*, extending from the frame of the casing A. At the end which carries the gear-wheel *g* each shaft E is closed by a plug *i*. At the opposite end of the casing and held rigidly in place is an air-conducting pipe F, provided with branch pipes F', which in the preferred construction communicate with tubes F², which extend through the bearings *f* and into the hollow shafts E to points adjacent to the plugged ends *i*. The tubes F² are stationary and each is formed on its under side with a longitudinal slot F³, (as shown most plainly in Fig. 3,) extending nearly the full length of the cylinder. Surrounding the tubes F², beyond the open ends of the shafts E, are stuffing-boxes *f'*. On the shafts E are spiral series of conveyer-blades E' on radial tubes E², open at their inner and outer ends. The tubes and blades extend nearly to the inner annular walls of the cylinder and the blades are set at an angle, as indicated. In the top of the casing A is an air-inlet G, and the pipe F communicates with the lower end of the casing at *k*. Interposed in the pipe F is an air-pump *k'*, which may be in the form of a fan-blower. Communicating with the steam-jacket *c* of each cylinder is a steam-supply pipe H, and extending from the lower side of each steam-jacket is a steam exhaust or drip pipe H'. In the casing A between the cylinders B and C is a horizontally-extending partition or baffle-plate I, extending from one end nearly to the opposite end, as shown, and between the cylinders C and D is a similar partition or baffle-plate I', extending from one end of the casing nearly to the other, as shown. The object of the baffle-plates I I' is to cause air entering at G

to travel the full length of the cylinder B, then of the cylinder C, and then of the cylinder D before it is withdrawn through the pipe at *k*.

5 In operation the shaft G^2 is rotated to rotate the shafts E. The conveyer-blades in the cylinders B D are so arranged that they convey from left to right (in Fig. 1) while the blades in the cylinder C convey from right to
10 left. The material to be dried is fed by any suitable means into the opening *d* of the uppermost cylinder B and in the rotation of the conveyers it is moved the full length of the cylinder B, then discharged through the pipe *e*
15 into the end of the cylinder C, then caused to travel the full length of said cylinder, then discharged into the cylinder D, and after traveling the full length of the last-named cylinder it is discharged through the outlet *e* of the cyl-
20 nder D. Steam is caused to enter through the pipes H and fill the steam-jackets *c* to maintain the cylinders hot. The air-pump *k'* is actuated to draw air through the opening *k* and discharge it into the branch pipes F' .
25 The air thus pumped is drawn into the casing at G, and traveling a zigzag course through the casing is heated by the outer walls of the steam-jackets to a more or less high tempera-
30 ture. The tubes or hollow shafts E fit closely around the inner stationary tubes F' , and in their rotation the inner ends of the radial tubes E^2 are closed by the valves formed by the tubes F' in their movement across the upper sides of the latter and opened as they
35 cross the slots F^2 . Thus the dry hot air entering the pipes F' from the pipe F is discharged only through the downward-extending pipes E^2 to the lower parts of the drying-
40 chambers, and this air being forced from the under side upward through the mass of grain or other material to be dried it penetrates the entire mass and quickly takes up the moisture therefrom. The moisture-laden air ris-
45 ing through the mass of grain or the like moves upward in the cylinders in the direction contrary to the movement of the grain and escapes at the grain-inlet and air-vent *d* of the upper drying-chamber. The construc-
50 tion described besides rendering the apparatus compact causes it to be economical in the use of steam, because practically all the heat of the steam is utilized, first, in heating the drying-chambers from the steam-jack-
55 ets, and, secondly, in heating air at the outer sides of the steam-jackets, which is afterward discharged into the drying-chambers, as described. The effect of discharging the heated air into the lower parts only of the
60 drying-chamber is to dry the mass of material quickly and so effectively as to give the apparatus comparatively great capacity. If desired, the air-induction means may be provided only in one, preferably the lower, dry-
65 ing-chamber.

In Fig. 4 I have shown a modified construction of the means for discharging the air only into the lower parts of the drying-chambers.

In this construction the rotating hollow shaft E is itself the air-conducting tube, communi-
70 cating with the pipe F' , and carries the radially-extending blade-carrying air-conducting tubes E^2 . In the tubes E^2 adjacent to their inner ends are valves *l*, pressed normally by
75 springs *l'* against their seats to close in the direction of the tube E. The valves *l* are upon stems l^2 , which project into the tubes E. In lieu
80 of the slotted tube F^2 of the preferred construction a stationary bar G extends longitudinally within the tube E and is shaped along its lower side with a cam-surface *m* in the path
85 of the valve-stems l^2 . In the rotation of the tube E with its radial tubes and conveyer-blades the valves *l* are opened as the stems l^2 pass across the cam-surface *m* and are
90 closed by the springs *l'* when they pass the said cam-surfaces. Thus, as in the preferred construction, hot dry air from the pipe F is discharged into the drying chamber or cham-
95 bers only from the radial tubes as they extend in the downward direction, whereby the air is forced to the under side of the mass of grain or the like to be dried.

Although my improved drying apparatus is designed more especially for use as a grain-
95 drier, it is not to be limited to any particular use, and while I prefer to construct it throughout, as shown and described, it may be variously modified in the matter of details of construction without departing from the spirit
100 of my invention, as defined by the claims.

What I claim as new, and desire to secure by Letters Patent, is—

1. In a drying apparatus, the combination of a drying-chamber having at one end an air-vent and inlet for the material to be dried,
105 and having at its opposite end an outlet for said material, means for stirring and conveying the material to be dried longitudinally through said chamber from said inlet to said
110 outlet, a steam-jacket about said chamber connected with a steam-supply, an air-chamber about said steam-jacket, and means for passing air through said air-chamber and dis-
115 charging it into the said drying-chamber, whereby the air passes through the said drying-chamber in the direction opposite to the direction of movement of said material.

2. In a drying apparatus, the combination of a series of drying-chambers disposed one
120 above the other and forming an endless convoluted passage for the material to be dried, means for stirring and conveying the said material successively through said chambers, a steam-jacket about each of said chambers
125 connected with a steam-supply, a casing about all said chambers forming an air-passage around said steam-jackets, an air-inlet toward one end of said air-chamber, an air-outlet toward the opposite end thereof, an
130 air-conduit extending from said outlet to the interior of said drying-chambers, and means for forcing air through said conduit, substantially as and for the purpose set forth.

3. In a drying apparatus, the combination

of a drying-chamber, means for stirring and conveying the material to be dried longitudinally through said chamber, a steam-jacket about said chamber connected with a steam-
5 supply, an air-chamber about said steam-jacket, and means for passing air through said air-chamber and discharging it into said dry-
ing-chamber in the lower part of the mass of said material therein, substantially as and for the purpose set forth.

ALEXANDER P. CRISWELL.

In presence of—

ALBERT D. BACCI,
ARTHUR MALDANER.