



US00D416524S

United States Patent [19]
Gabath

[11] **Patent Number: Des. 416,524**

[45] **Date of Patent: ** Nov. 16, 1999**

[54] **SURFACE CONFIGURATION OF A HOOD FOR A VEHICLE**

D. 396,432 7/1998 Syring D12/91

[75] Inventor: **Peter Gabath**, Starnberg, Germany

Primary Examiner—Melody N. Brown
Attorney, Agent, or Firm—Evenson, McKeown, Edwards & Lenehan, P.L.L.C.

[73] Assignee: **Bayerische Motoren Werke Aktiengesellschaft**, Munich, Germany

[57] **CLAIM**

[**] Term: **14 Years**

The ornamental design for a surface configuration of a hood for a vehicle, as shown and described.

[21] Appl. No.: **29/097,523**

[22] Filed: **Dec. 9, 1998**

[30] **Foreign Application Priority Data**

Jun. 10, 1998 [DE] Germany M 98 95 818

[51] **LOC (6) Cl.** **12-16**

[52] **U.S. Cl.** **D12/173**

[58] **Field of Search** D12/173, 90-92; 180/69.2, 69.21

DESCRIPTION

FIG. 1 is a front view of a surface configuration of a hood for a vehicle according to my novel design;

FIG. 2 is a top view of a surface configuration of a hood for a vehicle according to my novel design;

FIG. 3 is a left side view of a surface configuration of a hood for a vehicle according to my novel design, the right side view being mirror symmetrical; and,

FIG. 4 is a perspective view from the top left of a surface configuration of a hood for a vehicle according to my novel design, the perspective view from the top right being mirror symmetrical.

The broken lines shown in all drawing views are for illustrative purposes only and form no part of the claimed design.

[56] **References Cited**

U.S. PATENT DOCUMENTS

- D. 352,256 11/1994 Callum D12/91
- D. 374,202 10/1996 Yayashima D12/173
- D. 392,220 3/1998 Haussmann D12/91

1 Claim, 3 Drawing Sheets

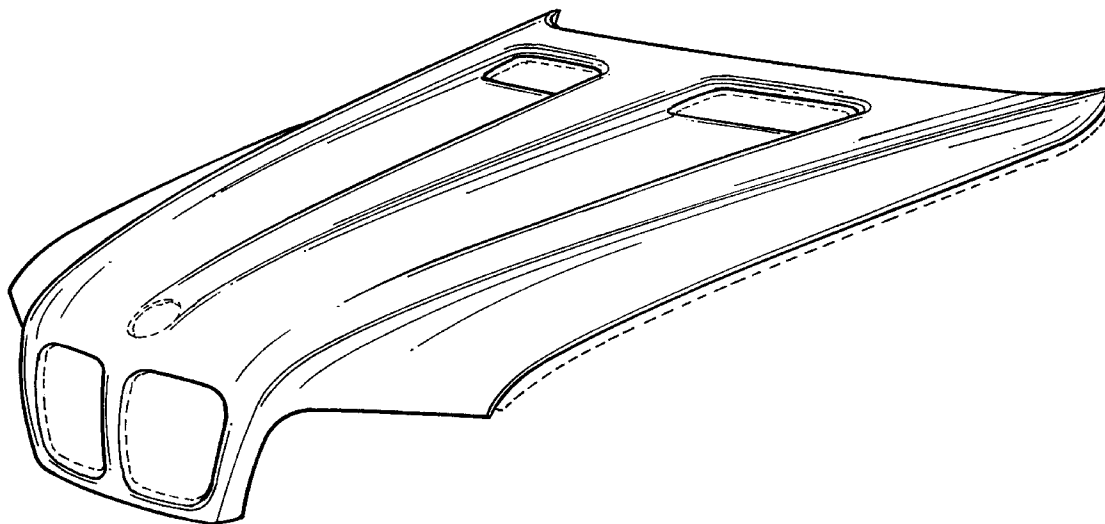

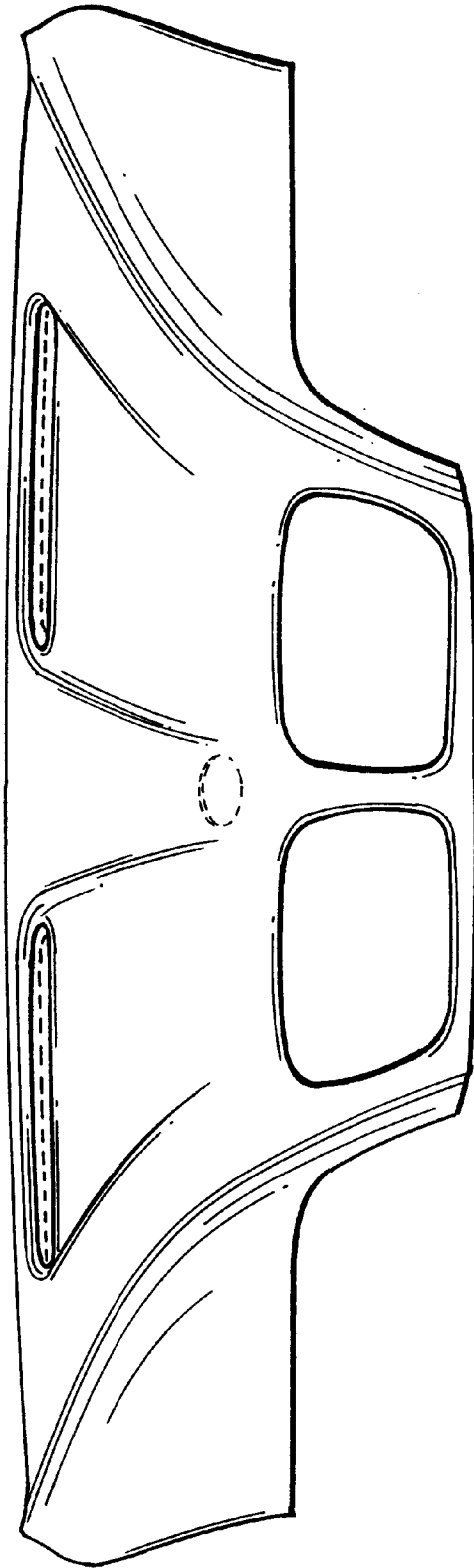

FIG. 1

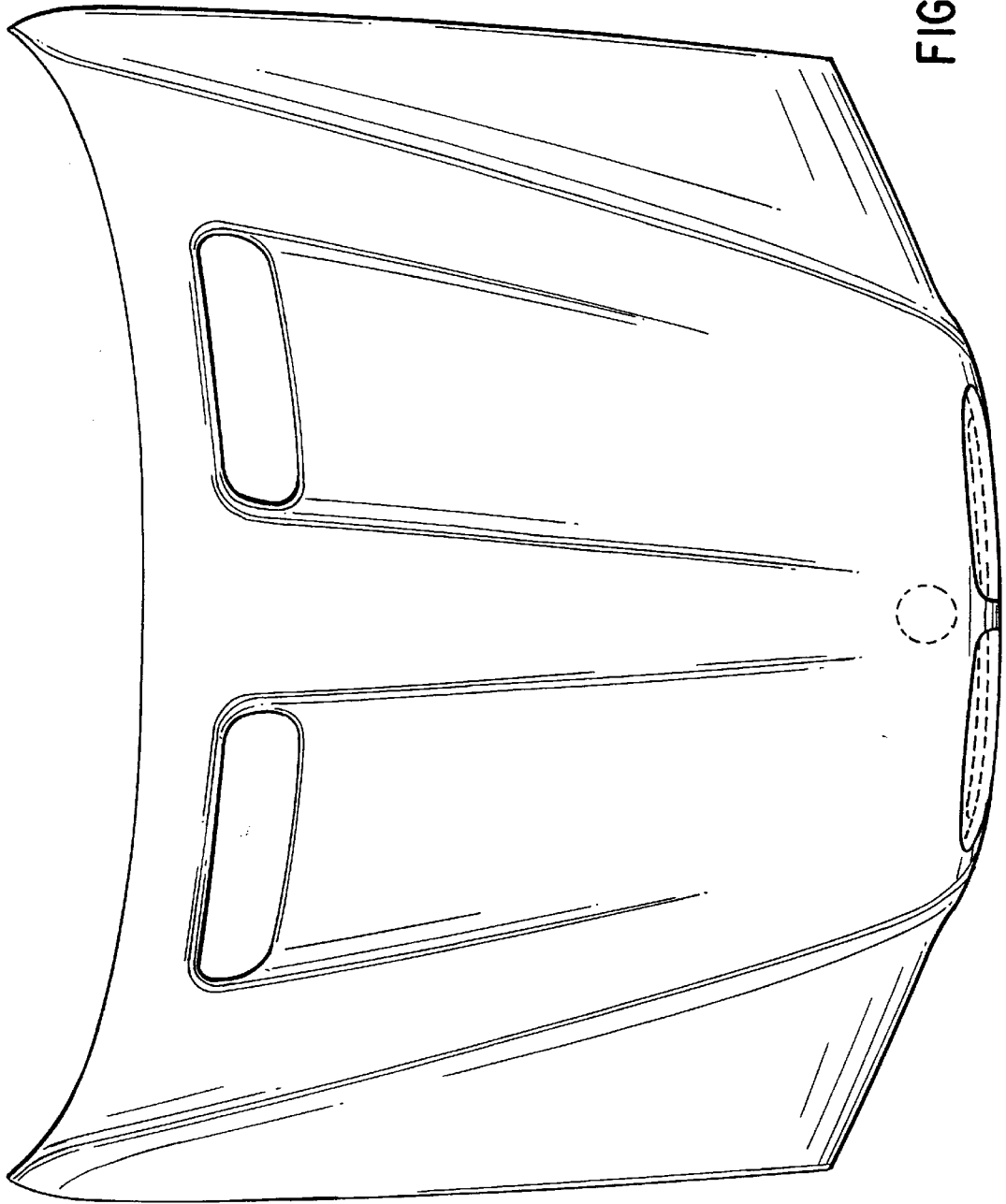

FIG. 2

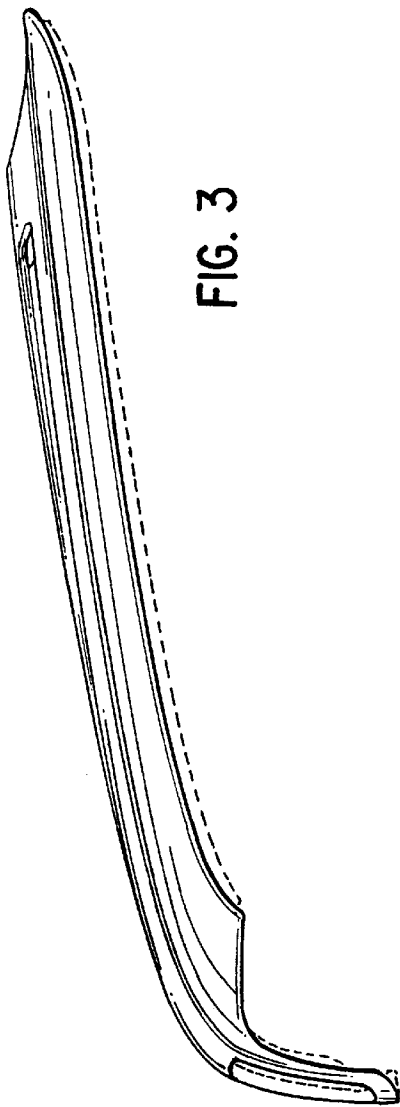

FIG. 3

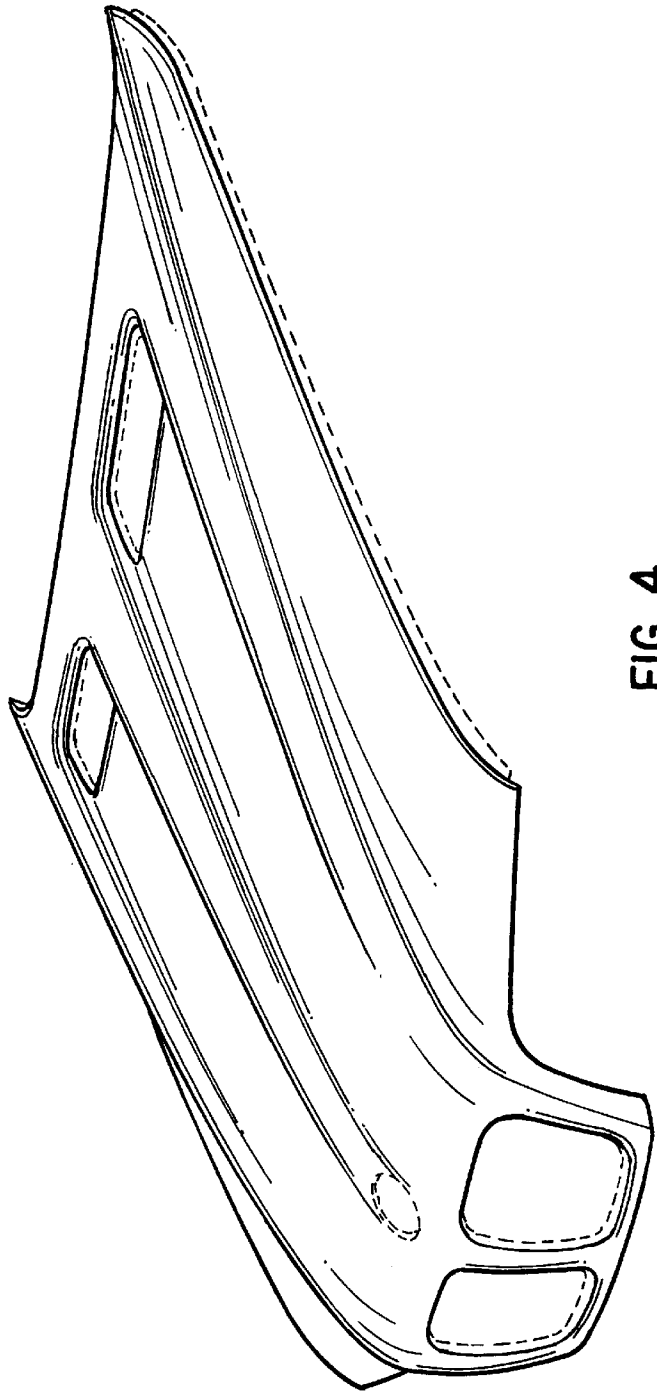

FIG. 4