



US00D338780S

United States Patent [19]

[11] Patent Number: Des. 338,780

Rance

[45] Date of Patent: ** Aug. 31, 1993

[54] STORAGE BOX FOR USE BEHIND THE SEAT OF A VEHICLE

4,917,279 4/1990 Brow 224/42.14

[76] Inventor: Charlie Rance, P.O. Box 106, Fernwood, Miss. 39635

FOREIGN PATENT DOCUMENTS

611892 10/1926 France .

618377 7/1980 Switzerland .

[**] Term: 14 Years

Primary Examiner—Louis S. Zarfes

Attorney, Agent, or Firm—Terry M. Gernstein

[21] Appl. No.: 683,656

[57] CLAIM

[22] Filed: Apr. 11, 1991

The ornamental design for a storage box for use behind the seat of a vehicle, as shown and described.

[52] U.S. Cl. D3/40; D12/155

[58] Field of Search D3/40, 70, 30.1; D12/155; 224/42.11, 42.14, 42.42, 273; 296/37.1, 37.6, 37.8, 37.16

DESCRIPTION

[56] References Cited

U.S. PATENT DOCUMENTS

D. 299,186	1/1989	Sills	D3/40
D. 299,287	1/1989	Gertler	D3/40
D. 310,304	9/1990	Carmichael	D12/155 X
4,227,737	10/1980	Vogt	296/76
4,832,193	5/1989	Kime	206/372

FIG. 1 is a perspective view of the storage box for use behind the seat of a vehicle embodying the design of the present invention;

FIG. 2 is a front elevational view thereof;

FIG. 3 is a rear elevational view thereof;

FIG. 4 is a side elevational view thereof, the side opposite being a mirror image of the side shown in FIG. 4;

FIG. 5 is a top plan view thereof; and,

FIG. 6 is a bottom view thereof.

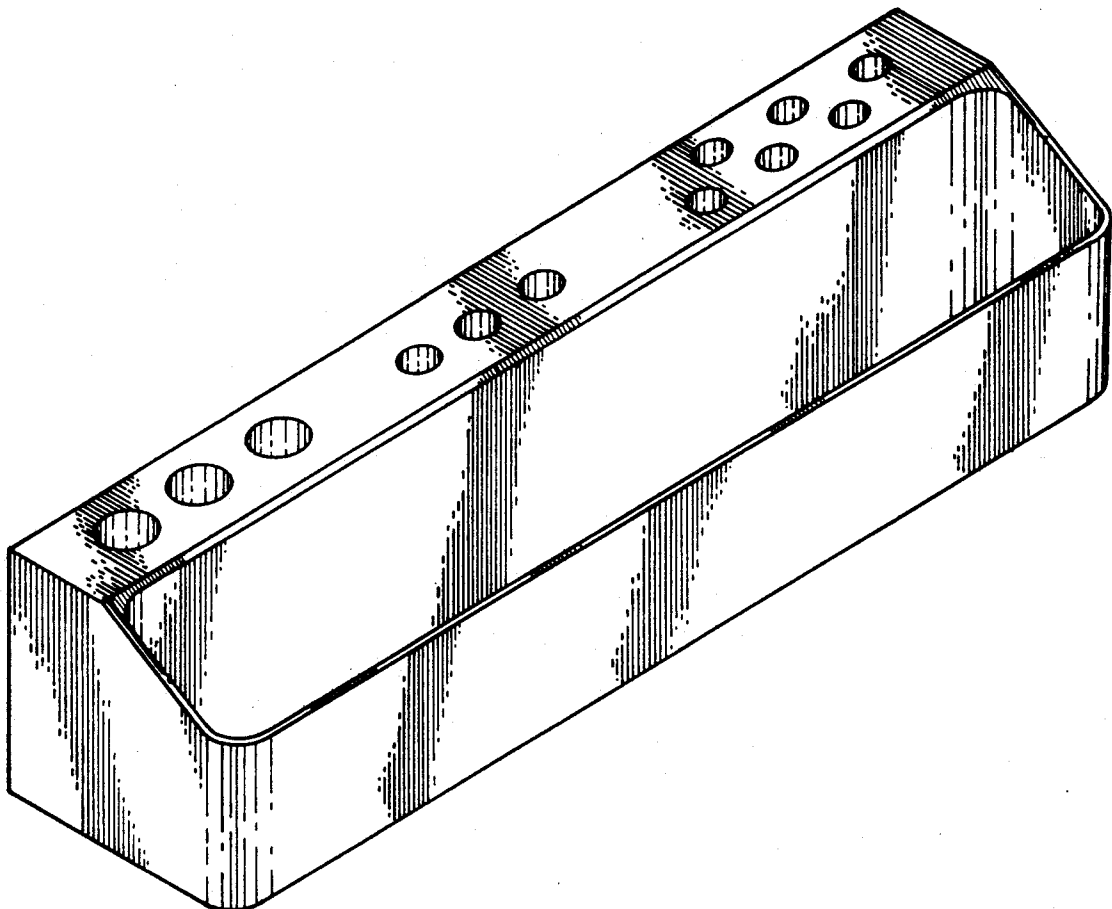

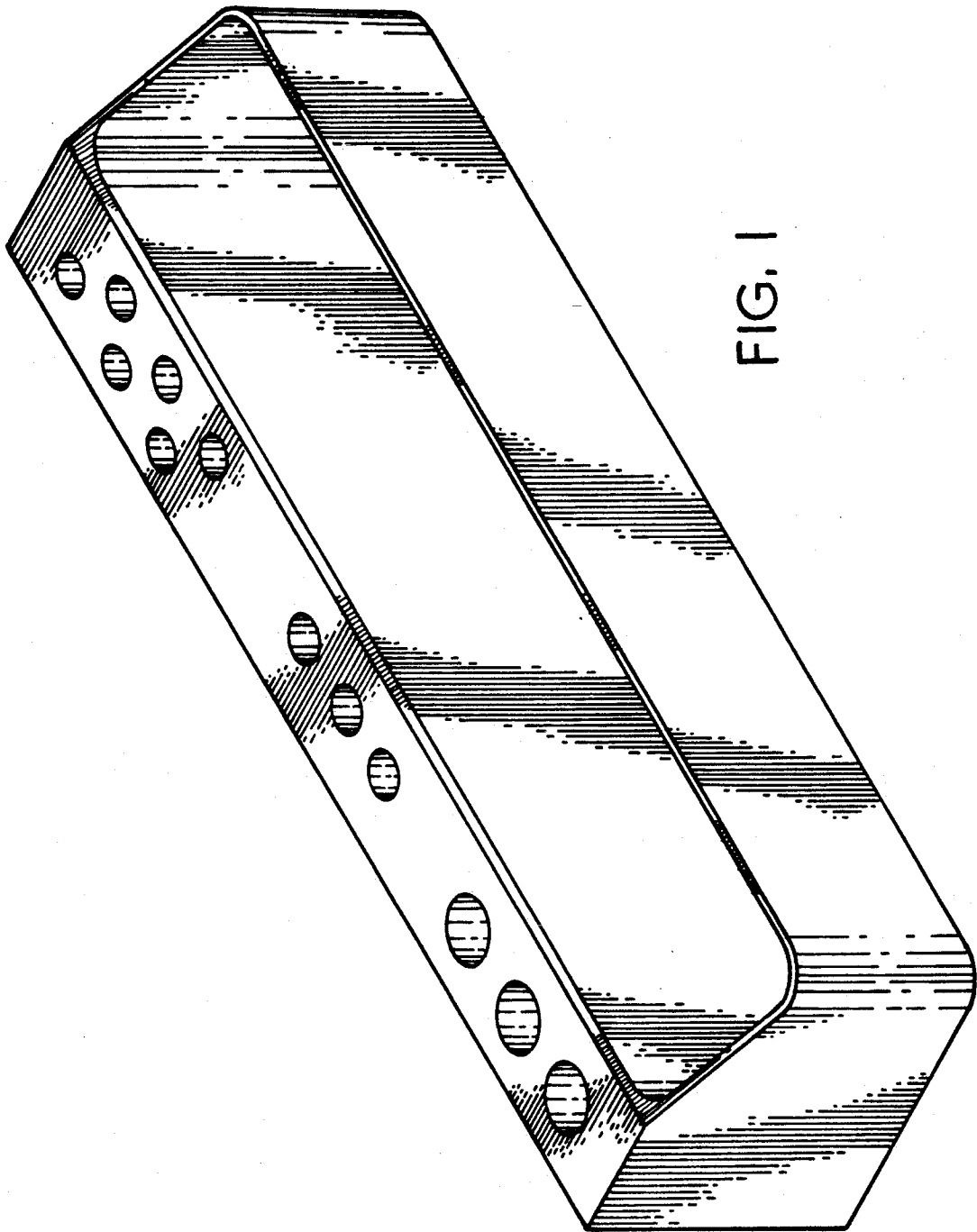

FIG. 1

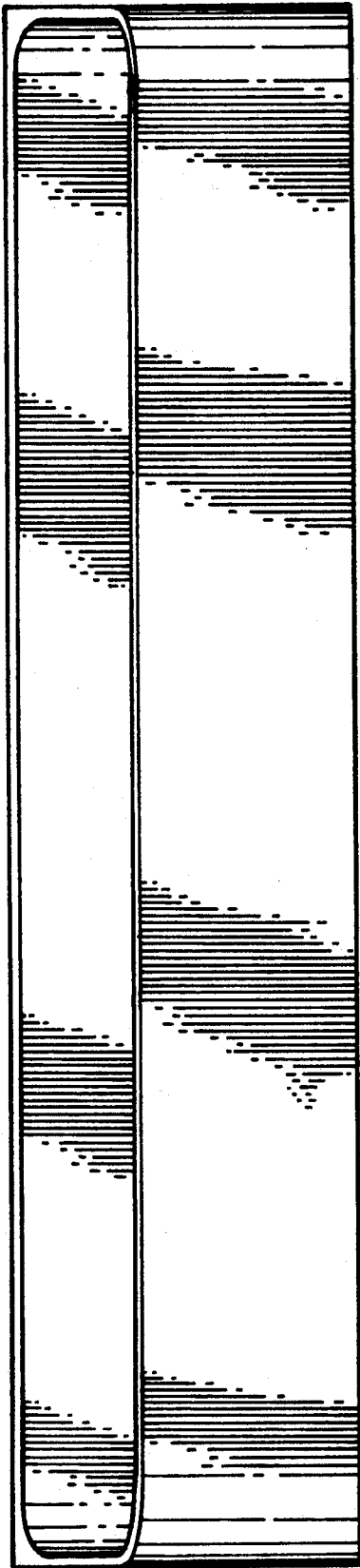

FIG. 2

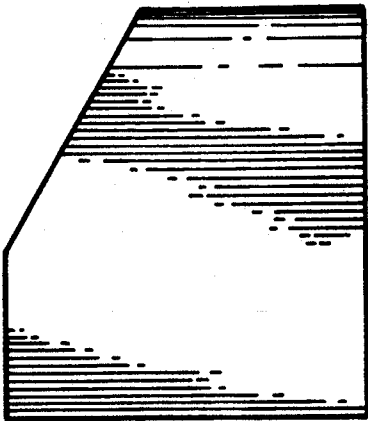

FIG. 4

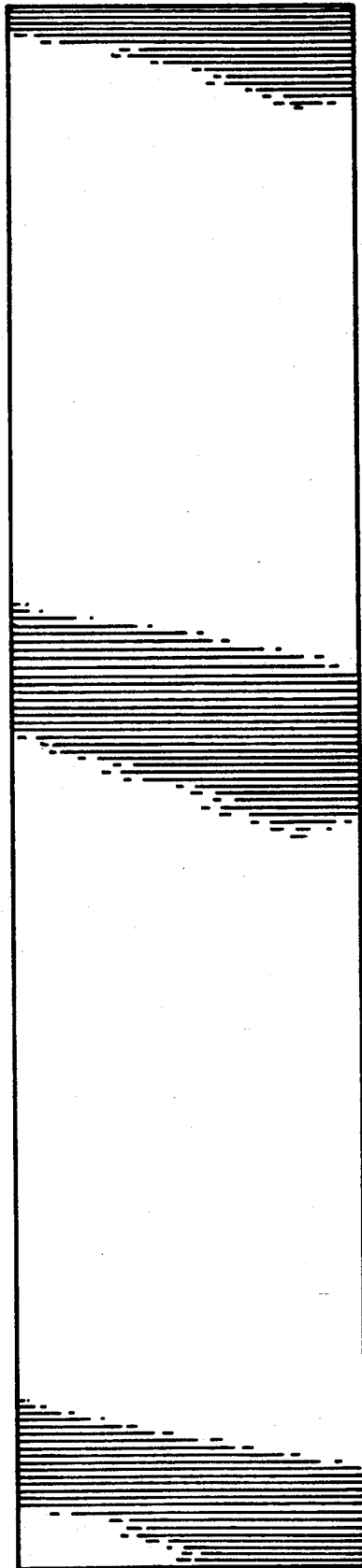

FIG. 3

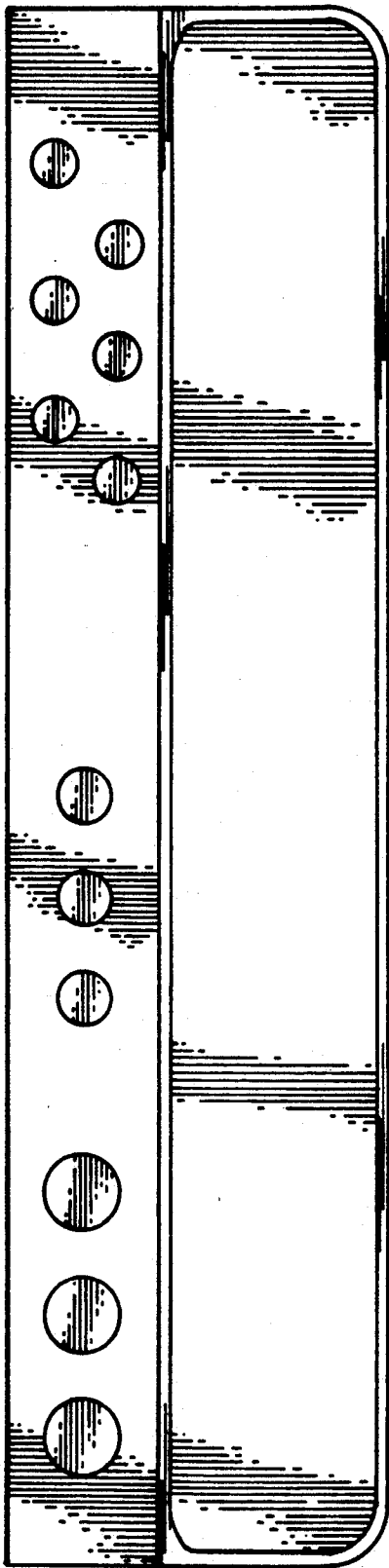

FIG. 5

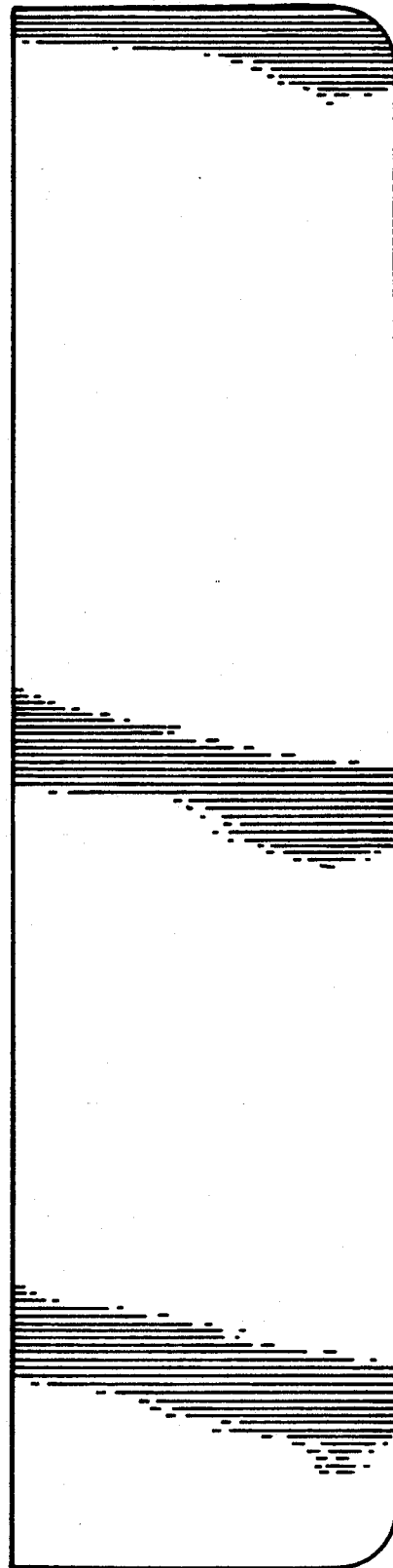

FIG. 6