

(12) PATENT
(19) AUSTRALIAN PATENT OFFICE

(11) Application No. AU 199719811 B2
(10) Patent No. 705815

(54) Title
Papermaking fabric, process for producing high bulk products and the products produced thereby

(51)⁶ International Patent Classification(s)
D21F 011/00 D21F 001/00

(21) Application No: 199719811 (22) Application Date: 1997 .02 .28

(87) WIPO No: W097/32081

(30) Priority Data

(31) Number	(32) Date	(33) Country
60/012696	1996 .02 .29	US
08/628235	1996 .04 .04	US
08/733934	1996 .10 .18	US

(43) Publication Date : 1997 .09 .16
(43) Publication Journal Date : 1997 .11 .13
(44) Accepted Journal Date : 1999 .06 .03

(71) Applicant(s)
Asten, Inc.

(72) Inventor(s)
Frederick W. Ahrens; Walter P Wright; Gary L. Worry; Thomas G. Gulya

(74) Agent/Attorney
WATERMARK PATENT and TRADEMARK ATTORNEYS, Locked Bag 5, HAWTHORN VIC 3122

(56) Related Art
US 4281688

OPI DATE 16/09/97 APPLN. ID 19811/97
AOJP DATE 13/11/97 PCT NUMBER PCT/US97/03141



AU9719811

(51) International Patent Classification 6 :
D21F 11/00, 1/00

A1

(11) International Publication Number: **WO 97/32081**

(43) International Publication Date: 4 September 1997 (04.09.97)

(21) International Application Number: PCT/US97/03141

(22) International Filing Date: 28 February 1997 (28.02.97)

(30) Priority Data:
60/012,696 29 February 1996 (29.02.96) US
08/628,235 4 April 1996 (04.04.96) US
08/733,934 18 October 1996 (18.10.96) US

(71) Applicant: ASTEN, INC. [US/US]; 4399 Corporate Road, P.O. Box 118001, Charleston, SC 29423-8001 (US).

(72) Inventors: AHRENS, Frederick, W.; 43 Parkview Lane, Hortonville, WI 54944 (US). WRIGHT, Walter, P.; 5263 White Pine Drive, Larsen, WI 54947 (US). WORRY, Gary, L.; 3040 West Spencer Street, Appleton, WI 54914 (US). GULYA, Thomas, G.; 6531-338 Paces Arbor Circle, Raleigh, NC 27609 (US).

(74) Agents: VOLPE, Anthony, S. et al.; Volpe and Koenig, P.C., 400 One Penn Center, 1617 John F. Kennedy Boulevard, Philadelphia, PA 19103 (US).

(81) Designated States: AL, AM, AT, AU, AZ, BA, BB, BG, BR, BY, CA, CH, CN, CU, CZ, DE, DK, EE, ES, FI, GB, GE, HU, IL, IS, JP, KE, KG, KP, KR, KZ, LC, LK, LR, LS, LT, LU, LV, MD, MG, MK, MN, MW, MX, NO, NZ, PL, PT, RO, RU, SD, SE, SG, SI, SK, TJ, TM, TR, TT, UA, UG, UZ, VN, ARIPO patent (GH, KE, LS, MW, SD, SZ, UG), Eurasian patent (AM, AZ, BY, KG, KZ, MD, RU, TJ, TM), European patent (AT, BE, CH, DE, DK, ES, FI, FR, GB, GR, IE, IT, LU, MC, NL, PT, SE), OAPI patent (BF, BJ, CF, CG, CI, CM, GA, GN, ML, MR, NE, SN, TD, TG).

Published
With international search report.

(54) Title: PAPERMAKING FABRIC, PROCESS FOR PRODUCING HIGH BULK PRODUCTS AND THE PRODUCTS PRODUCED THEREBY

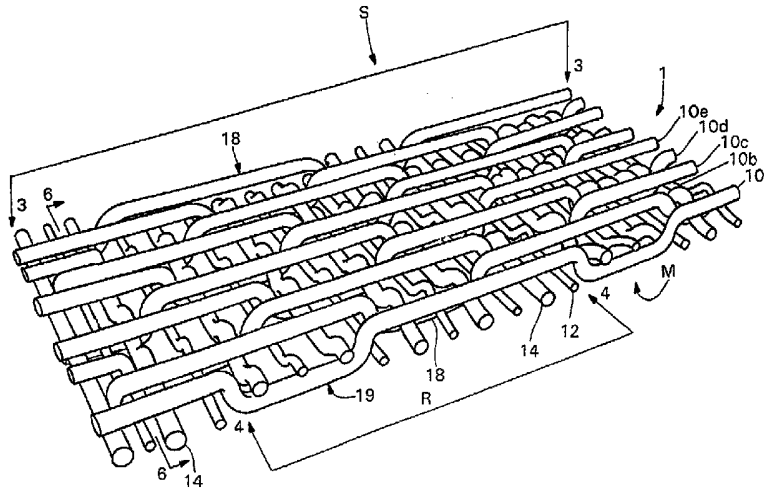

(57) Abstract

The present invention generally provides a broken twill, through-air drying (TAD) fabric for use in the formation of a paper web. The present invention more particularly provides a 7,3 broken twill TAD fabric which is potentially useful in forming large areas of high bulk and absorbency in the resulting paper product.

PAPERMAKING FABRIC, PROCESS FOR PRODUCING
HIGH BULK PRODUCTS AND THE PRODUCTS PRODUCED THEREBY

BACKGROUND OF THE INVENTION

Field of the Invention

5 The present invention relates to a fabric for use in a through-air drying (TAD) process for producing a high bulk, absorbent paper product.

BACKGROUND OF THE INVENTION

10 The physical attributes of a paper web are controlled not only by the web fibers, but also by the fabric on which the web is produced. The TAD fabric that is used to support the web and to form an impression in the web plays a central role in the development of the product attributes. The fabric character also has a significant effect on processing
15 attributes such as runnability and productivity.

 In a TAD process, the sheet side of the fabric refers to that side of the fabric which is generally used to contact the aqueous wet web. The back side refers to the side of the fabric which generally does not contact the web.

20 A variety of types of TAD fabrics have been proposed in an attempt to achieve good product attributes and processing efficiency. Early TAD fabrics were primarily single layer, plain weave, semi-twill, 4-shed or 5-shed fabrics. U.S. Patent No. 3,301,746 disclosed the use of square, diagonal twill and
25 semi-twill weaves. U.S. Patent No. 3,974,025 disclosed the use of the back side of a semi-twill TAD fabric. Another early development in TAD fabric technology is disclosed in U.S. Patent No. 4,239,065 to Trokhan. This patent discloses specific

weaves wherein the top-surface crossovers define a bilaterally staggered array of wicker-basket-like cavities where each cavity spans at least one sub-top-crossover.

5 TAD fabrics create bulk in a fibrous web by compacting the web only along related raised areas. Large portions of the fibrous web in the open areas or baskets between the raised areas are not compressed during the TAD process. These uncompressed areas are not only soft and absorbent but are higher in bulk. Single layer woven fabrics have the advantages
10 that they are inexpensive and efficient without creating difficult processing problems. However, these fabrics have the drawback that as the open areas are made larger, i.e., the size of the baskets which form non-compressed areas of the fibrous web are increased, these fabrics provide insufficient support
15 of the fibrous web. Lack of web support causes pinhole formation in the web, fiber bleed-through at the vacuum boxes, and air channeling, reducing both vacuum dewatering efficiency and TAD drying efficiency. Pinholing may negatively impact paper attributes including strength and visual appearance.

20 A prior art single layer fabric is shown in U.S. Patent No. 5,456,293. This fabric includes alternating larger and smaller weft yarns interwoven with warp yarns to form arrays of troughs and cavities diagonally along the length of fabric. This fabric may generally experience the problems discussed
25 above.

The present invention provides a woven fabric with sufficiently large open area to produce a soft, bulky paper web without the formation of pinholes, fiber bleed-through at the

AMENDED SHEET

-2a-

vacuum" boxes or air channeling problems. Furthermore, the present invention addresses these advantages in a single layer fabric.

AMENDED SHEET

SUMMARY OF THE INVENTION

It is also an object of the present invention to provide a through air drying fabric which is simple and inexpensive yet which produces a bulky and absorbent paper sheet.

5 It is further an object of the present invention to provide a fabric which reduces fiber bleed through and the occurrence of pin holes.

BRIEF DESCRIPTION OF THE DRAWINGS

10 **Figure 1** is an illustration of a process for forming a paper web using a through air dryer paper machine.

Figure 2 is a perspective view of a preferred embodiment of a papermaking fabric in accordance with the present invention.

15 **Figure 3** is a top plan view of the papermaking fabric taken along line 3-3 in **Figure 2**.

Figure 4 is a side elevation of the papermaking fabric taken along line 4-4 in **Figure 3**.

20 **Figure 5a-e** is a series of diagrammatic views illustrating the MD yarn weave pattern for the papermaking fabric of **Figure 2**.

Figure 6 is a side perspective view of the papermaking fabric taken along line 6-6 in **Figure 2**.

Figure 7 is a side elevation view of the papermaking fabric taken along line 7-7 in **Figure 6**.

25 **Figure 8a-b** is a series of diagrammatic views illustrating the smaller and larger diameter CD yarn weave patterns for the papermaking fabric of **Figure 2**.

Figure 9 is a top plan view of an alternate embodiment of the papermaking fabric of Figure 2.

Figure 10 is an illustration of the fabric knuckles and baskets which are used to impress the paper web according to the present invention.

DETAILED DESCRIPTION

The present invention is directed to a fabric for making a soft, high bulk and absorbency web. As illustrated in the TAD process of Figure 1, a web is formed on a forming structure (180) from a liquid slurry of pulp. The pulp is introduced from a headbox (10) to the forming structure. The forming structure can be a twin wire former, a crescent former or any art recognized forming configuration. The web is ultimately transferred from the forming structure to a carrier fabric which is a TAD impression fabric.

Referring to Figures 2-4, fabric 1 is shown in a 7/3 broken twill weave in accordance with the teachings of the present invention. Machine direction filaments (MD) 10 are interwoven with a system of alternating smaller and larger diameter cross direction filaments (CD) 12, 14. The fabric has a sheet side S, see Figure 3, and a machine side M, not separately illustrated, with the sheet side of fabric 1 defining the paper characteristics.

Figures 5a-e further illustrate the weave repeat R of Figure 2. Each MD filament 10 weaves over seven, and under three CD filaments 12, 14. Under each sheet side MD float 18 there are four smaller diameter CD filaments 12 and three

larger diameter CD filaments 14. The smaller diameter CD filaments 12 are positioned on each side of each larger diameter CD filament 14. Over each machine side MD float 19 there are one smaller diameter CD filament 12 and two larger diameter CD filaments 14. The smaller diameter CD filament 12 is parallel to and between the two larger diameter CD filaments 14. These relationships should be maintained in any weave variations from the above described weave.

As shown in **Figures 6-8**, the smaller diameter CD filament 12 weaves with the MD filaments 10 in a repeat pattern of over one and under four. The larger diameter CD filament 14 weaves with the MD filaments 10 in a repeat pattern of over one, under one, over one, under two. Since the CD repeat lengths relative to the MD yarns 10 are equal, each sheet side knuckle 13 formed by a smaller diameter CD filament 12 is adjacent to and between a pair of sheet side knuckles 15 formed by the larger diameter CD filaments 14. Since the MD filaments 10 are in a relatively higher plane than the smaller diameter CD filaments 12 and float over a number of CD filaments 14, the MD floats 18 dominate the sheet side S of the fabric 1. These higher profile MD floats 18 cause compression in the paper sheet (not shown) when it is on fabric 1.

The combination of the long sheet side MD floats 18 and knuckles of CD filaments 14 forms a rim around the basket-like depressions in the sheet side of fabric 1. The lower plane knuckles of CD filaments 12 do not interfere with the baskets where they appear and the long machine side floats of the CD filaments 12 provide a lower support or base for the fibers.

The paper fibers in these basket forms are relatively uncompressed in comparison to the fibers in contact with the MD floats 18 and CD knuckles 15.

Each basket is defined by at least two MD filaments 10 on
5 two sides and two larger diameter CD filaments 14 on the
remaining two sides. The compression areas on the sheet side of
the fabric are aligned in the CD direction and are staggered in
the MD direction thereby forming diagonally aligned baskets
10 along the length of the fabric 1. The pattern of the weave
causes larger and smaller baskets to form. In a single CD line
of baskets, the CD length of the baskets alternates. If the
shorter basket is deemed of length 1 then the longer basket is
approximately of length 1-1/2. The shorter basket also has
15 slightly less MD length and caliper than the longer baskets.
These baskets are illustrated by the darkened areas 26 and 28
in Figure 10.

As shown in Figures 6, 8a and 8b, the smaller diameter CD
filaments 12 are predominately in the lower portion of the
fabric 1 and provide additional support for uncompressed nubs
20 12 that allow a paper sheet, not shown, to imprint deeply on
fabric 1 without fiber bleed through or hole formation. In
addition, the location of the smaller diameter CD filaments 12
in the lower portion of the fabric provides the desired
additional fiber support without unduly blocking the drainage
25 holes 16, see Figure 3, in fabric 1.

In an alternate embodiment of the present invention, shown
in Figure 9, the fabric 2 is surfaced to increase the contact
area and provide a more monoplane sheet side. The fabric 2 is

surfaced until the larger diameter CD filaments 14 are reached at 24. Surfacing of MD and CD filaments 10 and 14 causes additional sheet contact on the added surface area that compresses fibers while the baskets between the surfaced floats 21 and knuckles 24 create areas of uncompressed paper fibers. Large 28 and small 26 baskets are shown by the darkened areas in Figure 10.

In either embodiment the MD and CD filaments may be polyester, polyamide, vinyl, acrylic, nylon, or other materials as known in the art. In a preferred embodiment of the present invention, the filaments are made of polyester which has been treated for hydrolysis resistance. The MD filaments and CD filaments need not be of the same material. The smaller diameter CD filaments may also differ in composition from the larger MD and CD filaments. For example, hollow, compressible yarns may be utilized instead of solid filaments for the smaller diameter CD filaments. Hollow yarns will provide additional resiliency and compressibility to the fabric. Suitable yarns are described in U.S. Patent No. 5,368,696 which is incorporated by reference as if fully set forth herein. Preferably, the hollow core of the yarns have a void range of fifteen to thirty percent (15%-30%).

In the preferred embodiment the larger diameter CD filaments 14 range between about 0.3 to 0.6 mm and preferably about 0.4 to 0.5mm. The smaller diameter CD filaments 2 range between about 0.15 and about 0.3 mm and preferably about 0.2 mm. Preferably, the diameter of the larger CD yarns is at least equal to the diameter of the MD yarns.

In a preferred embodiment of the present invention, the fabric as woven achieves an air permeability in the range of 600 to 800 CFM and most preferably about 700 CFM, as tested on a Frazier air permeability tester. The fabric of the present invention preferably has an open area, as seen in **Figure 3**, in the range of ten to twenty-five percent (10%-25%), and most preferably about 20.0 percent (20.0%).

The MD filaments and the larger CD filaments are preferably monofilaments. The smaller CD yarn or filament may be of any configuration, for example, monofilament, multi-filament cable, flat monofilament or flat monofilament with holes therethrough, as will be understood by the skilled artisan.

The ratio of the larger diameter CD filaments to the smaller CD filaments diameter is preferably 1.5:1 to 4:1, more preferably 2:1.

The fabric of the present invention may be woven in an endless configuration or may be woven flat. The description set forth in the present specification is based upon a fabric that has been woven flat with the warp filaments running in the machine direction. It will be apparent to the skilled artisan that the machine direction and cross machine direction yarns may be reorientated for an endless weaving process.

The fabric according to one embodiment of the present invention has a mesh count of 20 to 50 filaments per inch of cross direction distance, more preferably 30 to 40 filaments per inch of cross direction distance. The fabric according to one embodiment of the present invention has a mesh count

sufficient to prevent pinholing of the fibrous web. It is presently preferred that the mesh count be no less than 20. The fabric according to one embodiment of the present invention has a mesh count of 20 to 50 filaments per inch of machine direction distance, more preferably at least 30 filaments per inch of machine direction distance.

The fabric of the present invention may be further treated to improve the contact area thereof. Any art recognized method for increasing contact area can be used. Exemplary methods are described in U.S. Patent No. 3,579,164, which issued March 30, 1971, to Friedberg et al. This patent discloses surfacing or abrading the high points of strand crossovers to provide flat surfaced regions. Contact area refers to the amount of fabric surfacing. The fabric of the present invention preferably has a contact area in the range of 20% to 40%, more preferably 25 to 35%, and most preferably about 30%.

The fabric of the present invention may also be described in terms of orientation of the open areas or baskets and contact areas of floats or knuckles. The fabric of the present invention has alternating large and small basket sizes. Basket and nub sizes are measured at the maximum point between two sides and all measurements are based upon the fabric prior to treatments such as abrading to increase contact area. The larger baskets and nubs are larger than about 40 mils by 40 mils, more preferably in the range of about 60 mils by 40 mils to about 120 mils by 100 mils, most preferably about 80 mils by 50 mils. The smaller baskets and nubs are larger than about 20 mils by 30 mils. The baskets also have different depths and

thus the corresponding nubs have different heights. The large baskets are preferably about 0.3 to 0.7 mm deep, more preferably about 0.3 to 0.5 mm deep and most preferably about 0.4 mm deep. The smaller baskets are preferably about 0.15 to 5 0.4 mm deep, more preferably about 0.2 to 0.3 mm deep, and most preferably about 0.25 mm deep. The baskets are tri-directionally aligned. The large and small baskets are aligned in the cross direction and the large and small baskets are each aligned in both diagonal directions.

10 The fabric as described herein is used preferably in the TAD with the long warp knuckles on the sheet side.

A test fabric was woven using PET monofilaments which had been treated to render them hydrolysis resistant. The large diameter monofilaments were 0.4 mm. The smaller diameter 15 filaments were 0.2 mm. The fabric was woven using all large diameter monofilaments in the machine direction and alternating large and small diameter filaments in the cross direction.

The large diameter MD filaments and large diameter CD filaments were interwoven to create a 7,3 broken twill fabric. 20 The alternating CD filaments were only interwoven to the extent necessary to secure them for support of the fibers. The mesh count for the fabric produced was 35 machine direction filaments per inch and 46 cross direction filaments per inch.

The woven fabric was treated to impart heat and 25 dimensional stability. The fabric was further treated by sanding the MD knuckles to increase the contact area of the web to 28%.

The fabric was then seamed by the known technique by fraying out the ends and backweaving them into the fabric body to form a continuous or endless fabric.

"comprises/comprising" when used in this specification is taken to specify the presence of stated features, integers, steps or components but does not preclude the presence or addition of one or more other features, integers, steps, components or groups thereof

3
3
3
3

3
3
3

3
3

THE CLAIMS DEFINING THE INVENTION ARE AS FOLLOWS:

1. A papermaking fabric (1,2) having a sheet side (S) and a machine side (M) including a system of MD filaments (10) selectively interwoven with a system of CD filaments (12,14), the CD filaments (12,14) having at least two subsets of filaments that have larger (14) and smaller (12) diameter filaments; whereby the weave forms a plurality of depressions (26,28) in the sheet side (S) of the fabric (1,2), the fabric (1,2) characterized by:

the MD filaments (10) forming sheet side floats (18) in the MD direction that have a minimum float of seven CD system filaments (12,14);

the larger diameter CD filaments (14) define only knuckles (15) on the sheet side (S); and

the smaller diameter CD filaments (12) define only sheet side knuckles (13) and machine side floats.



2. The papermaker's fabric (1,2) of claim 1, wherein three of said seven cross direction filaments (12,14) of each MD sheet side float (18) are of the larger diameter (14) and four of said seven cross direction filaments (12,14) are of the smaller diameter (12).



3. The papermaker's fabric (1,2) of claim 1, wherein each machine direction filament (10) is woven under three cross direction filaments (12,14), wherein two of said three cross direction filaments (12,14) are of the larger diameter (14) and one of said three cross direction filaments (12,14) is of the smaller (12) diameter.



4. The papermaker's fabric (1,2) of claim 1, wherein the machine direction filaments (10) and the larger diameter cross direction filaments (14) are of an equal diameter.

5. The papermaker's fabric (1,2) of claim 1, wherein the machine direction filaments (10) and the cross direction filaments (12,14) are all monofilaments.

6. The papermaker's fabric (1,2) of claim 1, wherein the fabric (1,2) has a mesh count in the cross direction of from 20 to 50 filaments per inch.

7. The papermaker's fabric (1,2) of claim 1, wherein the fabric (1,2) has a mesh count in the machine direction of from 20 to 50 filaments per inch.

8. The papermaker's fabric (2) of claim 1, wherein the fabric (2) is sanded on the sheet side (S).

9. The papermaker's fabric (2) of claim 8, wherein the fabric (2) is sanded to a contact area of 20 to 40%.

10. The papermaker's fabric (1,2) of claim 1, wherein the fabric (1,2) is a forming fabric.

11. In combination with a papermaking through air dryer apparatus having at least one through-dryer position, a through-dryer papermaking fabric (70) including

a single layer fabric (1,2) having machine direction filaments (10) interwoven with alternating larger (14) and smaller (12) cross machine filaments to form a pattern of knuckles (13,15) and baskets (26,28), the fabric (1,2) characterized by:

the MD filaments (10) forming sheet side floats (10) in the MD direction that have a minimum float of seven CD system filaments (12,14);

the larger diameter CD filaments (14) define only knuckles (15) on the sheet side (S); and

the smaller diameter CD filaments (12) define only sheet side knuckles (13) and machine side floats.

12. The papermaker's fabric (1,2) of claim 1, wherein the smaller CD filaments (12) form machine side (M) floats in the CD direction that have a minimum length of four MD system filaments (10).

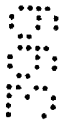

13. The fabric (1,2) of claim 12, wherein the smaller CD filaments (12) weave in a repeat pattern of under four, over one MD filament (10).

14. The fabric (1,2) of claim 12, wherein the larger CD filament (14) weaves in a repeat pattern of over one, under one, over one, under two MD filaments (10).

15. The fabric (1,2) of claim 12, wherein the knuckles (13) formed by the smaller diameter CD filaments (12) coincide with the knuckles (15) of the larger diameter CD filaments (14).

16. The fabric (1,2) of claim 15, wherein the smaller CD filaments (12) weave in a repeat pattern of under four MD filaments, over one MD filament (10).



17. The fabric (1,2) of claim 1, wherein the knuckles (13) formed by the smaller diameter CD filaments (12) coincide with knuckles (15) formed by the larger diameter CD filaments (14).

18. A papermaking fabric as hereinbefore described with reference to any one of Figures 2 to 10.



DATED THIS 23RD DAY OF MARCH 1999

ASTEN, INC.



WATERMARK PATENT & TRADEMARK ATTORNEYS

290 BURWOOD ROAD

HAWTHORN VICTORIA 3122

AUSTRALIA

IAS:JPF:SLB

DOC 26 AU1981197.WPC

1/8

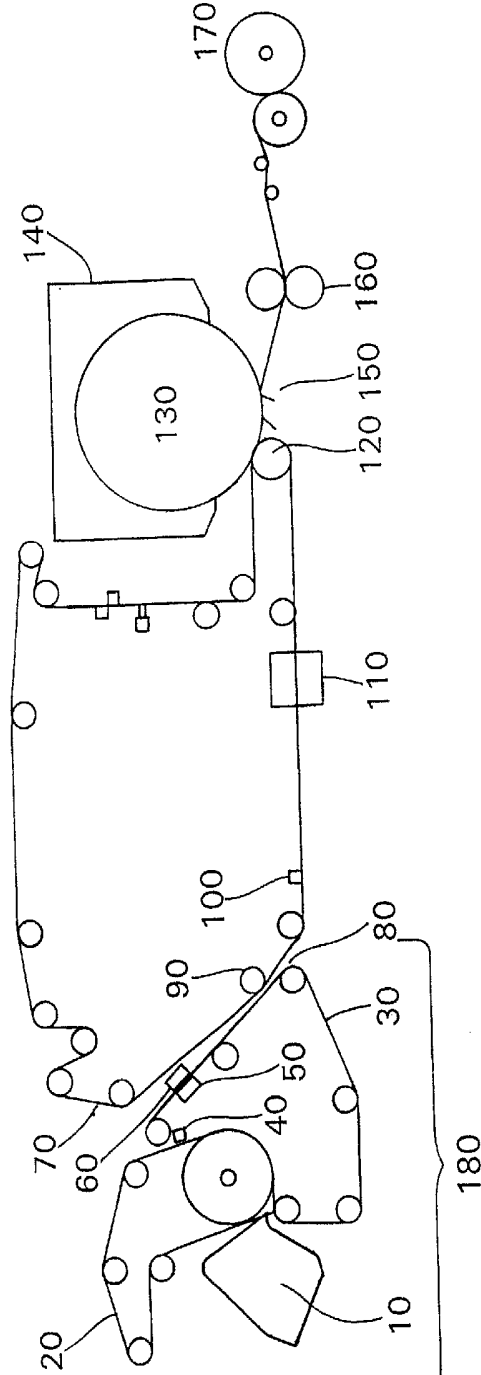

Fig. 1

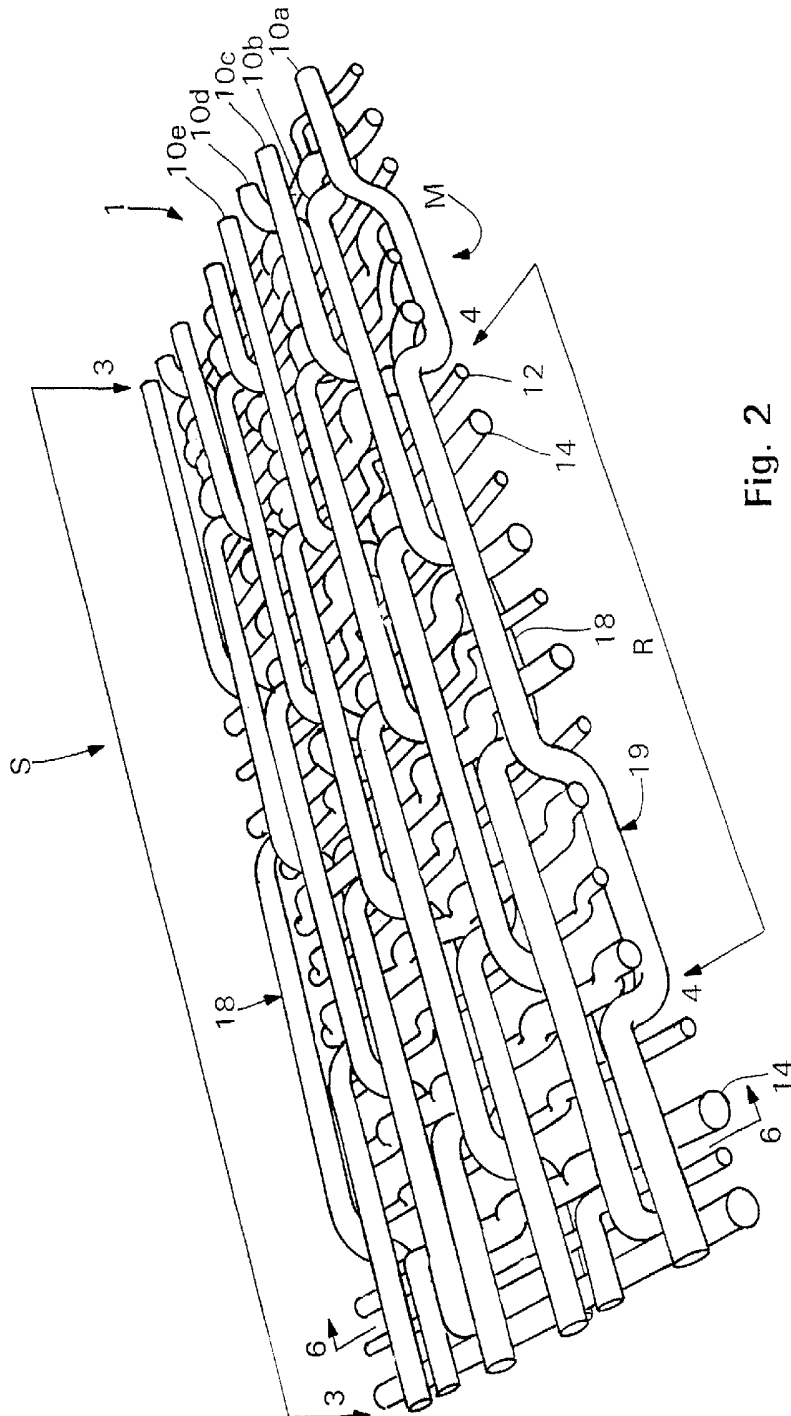

Fig. 2

SUBSTITUTE SHEET (RULE 26)

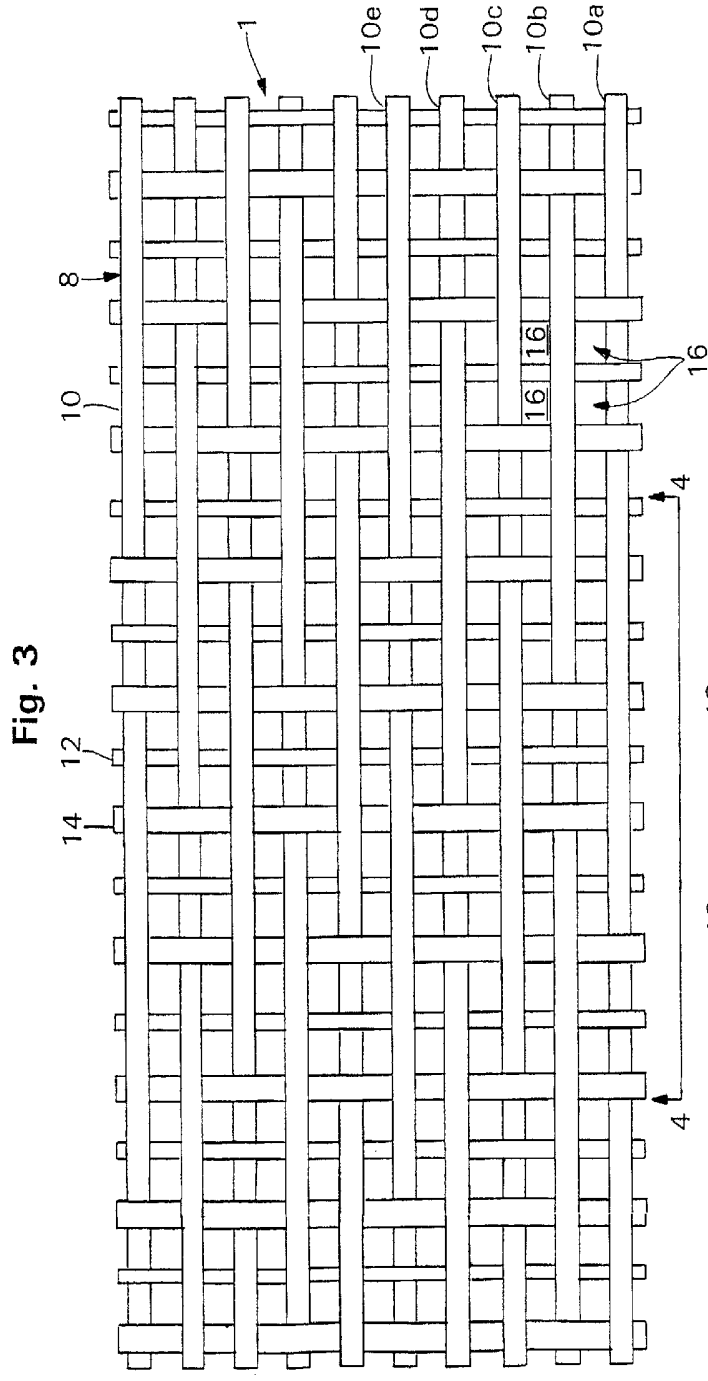

Fig. 3

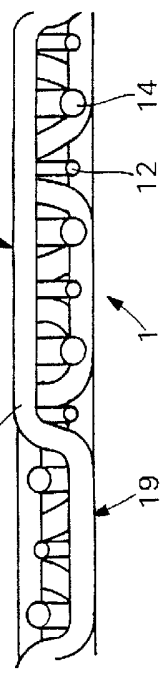
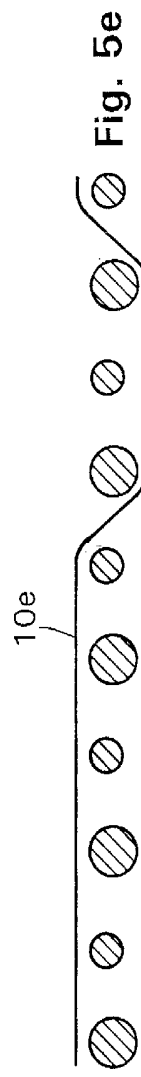
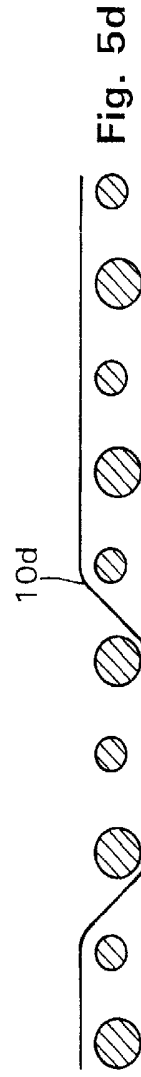
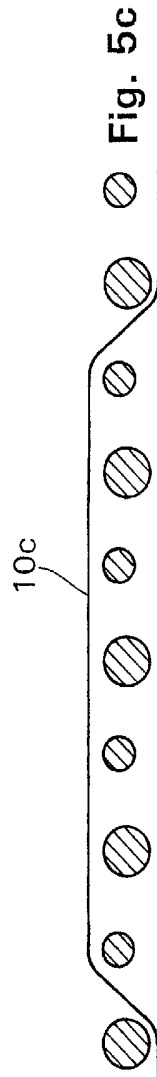
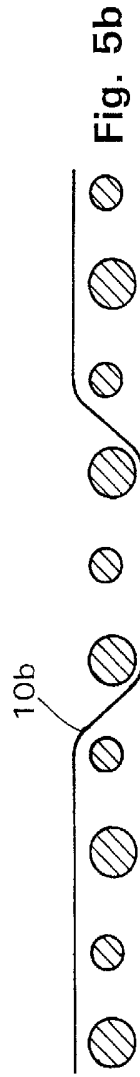
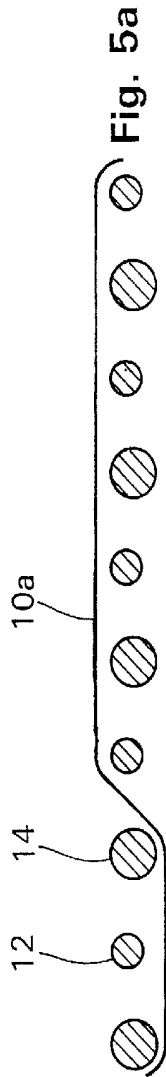

Fig. 4



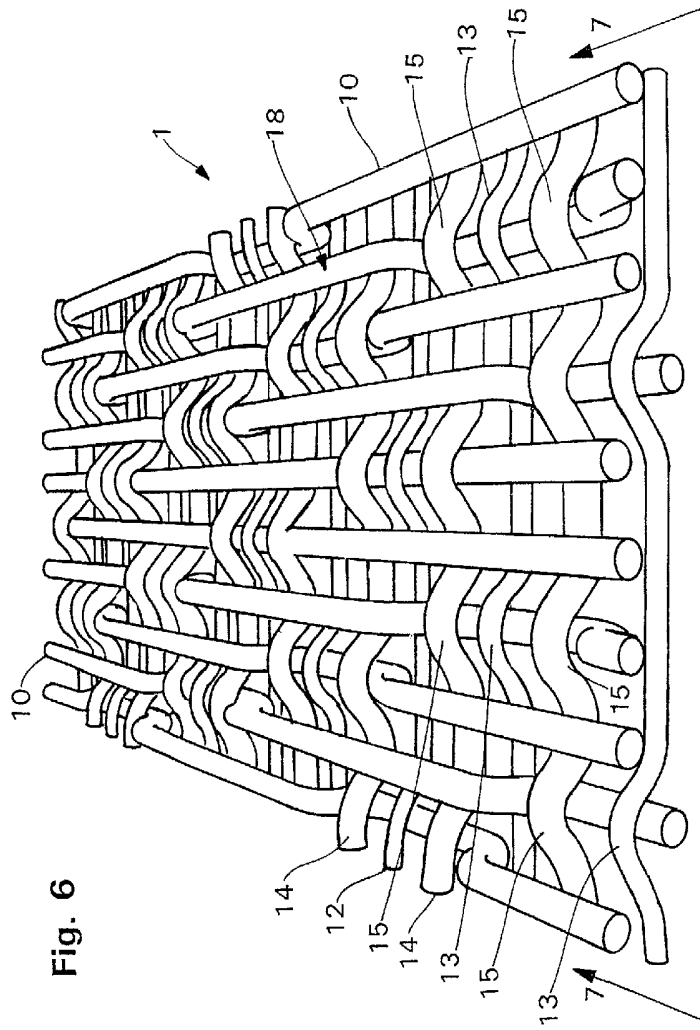

Fig. 6

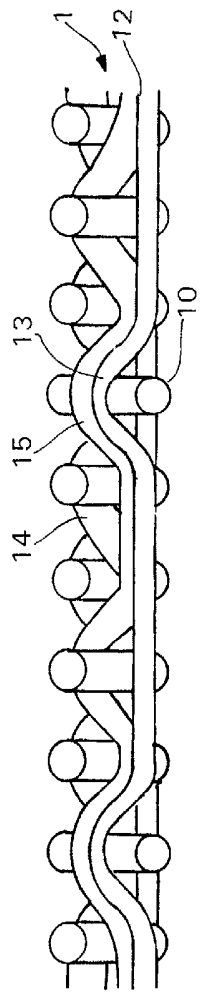
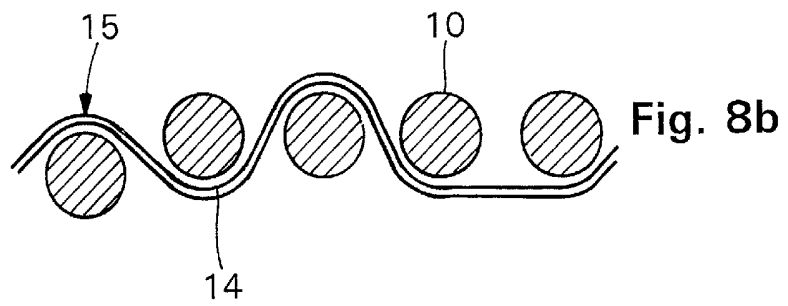
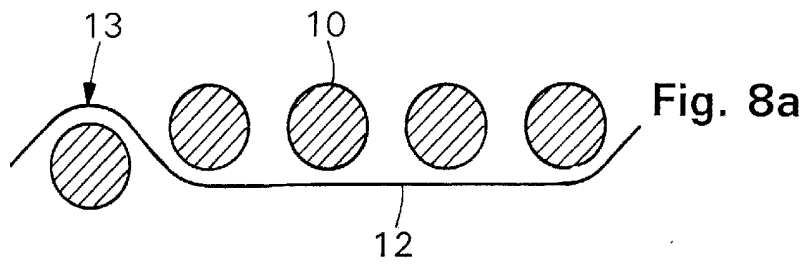

Fig. 7



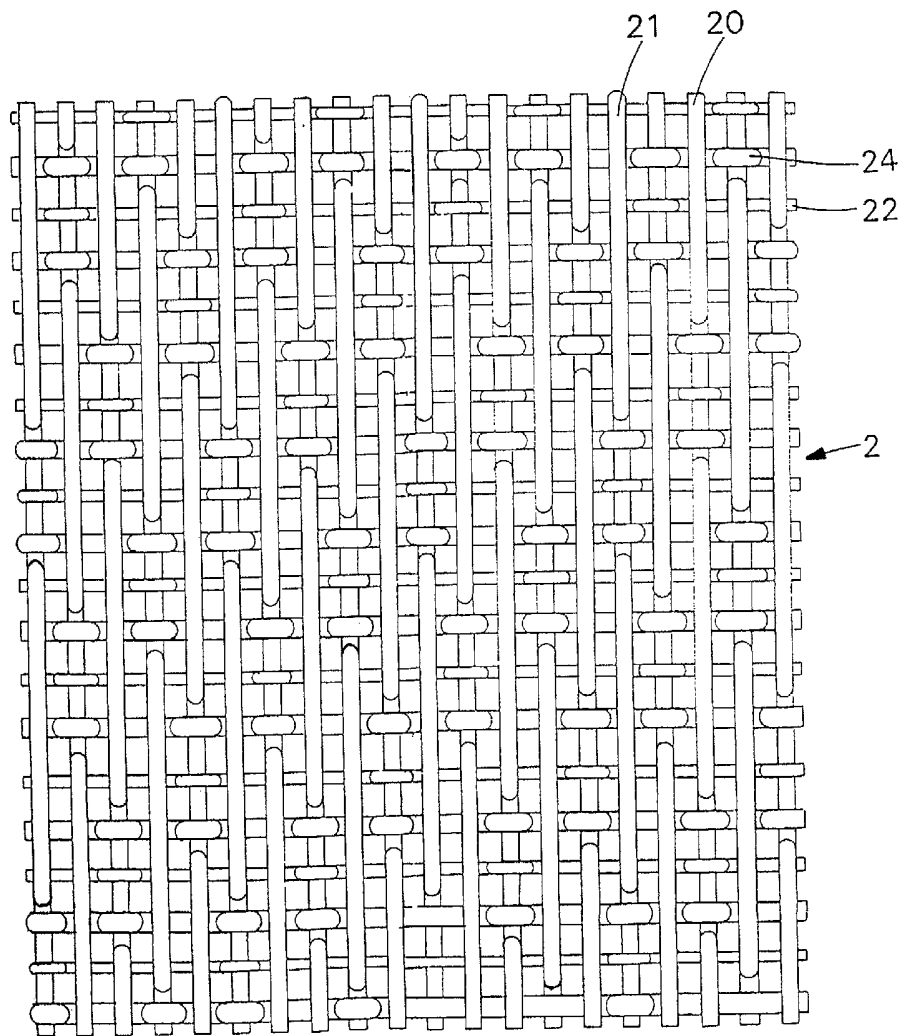

Fig. 9

SUBSTITUTE SHEET (RULE 26)

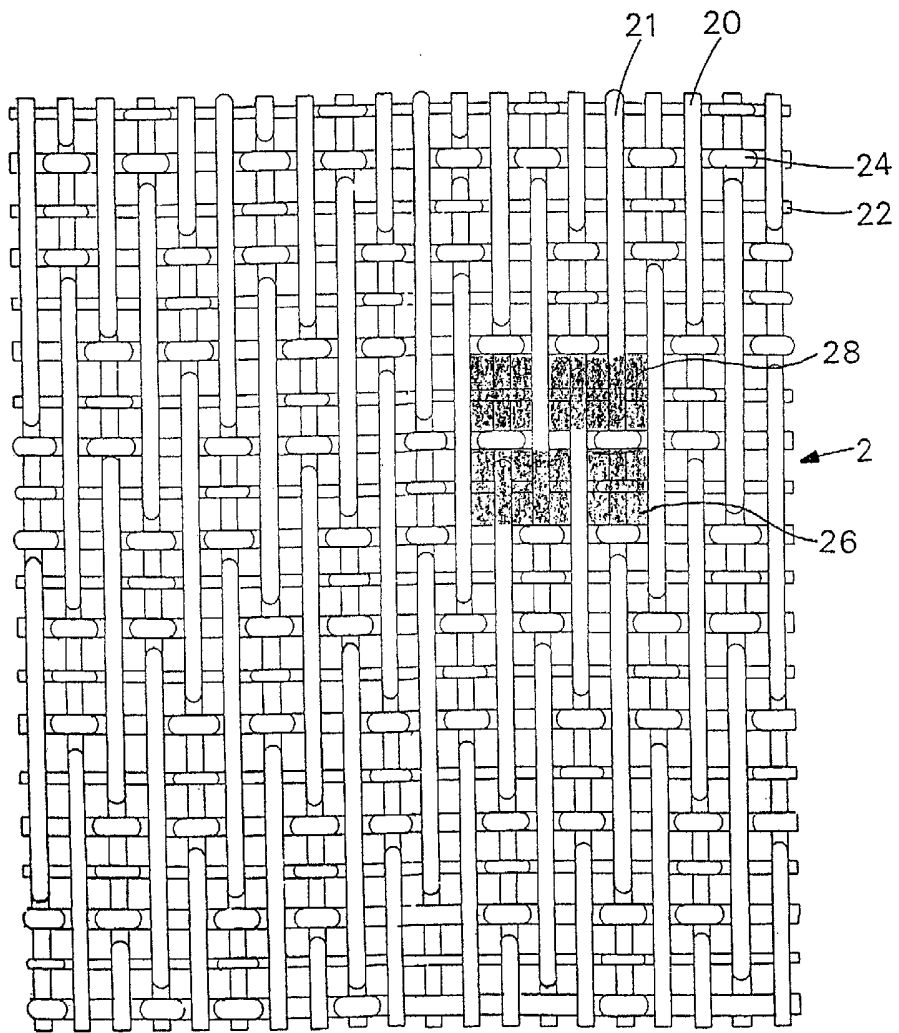

Fig. 10

SUBSTITUTE SHEET (RULE 26)