



INTERNATIONAL APPLICATION PUBLISHED UNDER THE PATENT COOPERATION TREATY (PCT)

<p>(51) International Patent Classification ⁶ : A61N 1/30</p>	<p>A1</p>	<p>(11) International Publication Number: WO 97/48441</p> <p>(43) International Publication Date: 24 December 1997 (24.12.97)</p>
---	------------------	--

(21) International Application Number: PCT/US97/10595

(22) International Filing Date: 18 June 1997 (18.06.97)

(30) Priority Data:
60/019,990 18 June 1996 (18.06.96) US

(71) Applicant: ALZA CORPORATION [US/US]; 950 Page Mill Road, P.O. Box 10950, Palo Alto, CA 94303-0802 (US).

(72) Inventors: CORMIER, Michel, J., N.; 278 Andsbury Avenue, Mountain View, CA 94043 (US). THEEUWES, Felix, T.; 27350 Altamont Road, Los Altos, CA 94022 (US).

(74) Agents: MILLER, D., Byron et al.; Alza Corporation, 950 Page Mill Road, P.O. Box 10950, Palo Alto, CA 94303-0802 (US).

(81) Designated States: AL, AM, AT, AU, AZ, BA, BB, BG, BR, BY, CA, CH, CN, CU, CZ, DE, DK, EE, ES, FI, GB, GE, HU, IL, IS, JP, KE, KG, KP, KR, KZ, LC, LK, LR, LS, LT, LU, LV, MD, MG, MK, MN, MW, MX, NO, NZ, PL, PT, RO, RU, SD, SE, SG, SI, SK, TJ, TM, TR, TT, UA, UG, UZ, VN, ARIPO patent (GH, KE, LS, MW, SD, SZ, UG, ZW), Eurasian patent (AM, AZ, BY, KG, KZ, MD, RU, TJ, TM), European patent (AT, BE, CH, DE, DK, ES, FI, FR, GB, GR, IE, IT, LU, MC, NL, PT, SE), OAPI patent (BF, BJ, CF, CG, CI, CM, GA, GN, ML, MR, NE, SN, TD, TG).

Published
*With international search report.
Before the expiration of the time limit for amending the claims and to be republished in the event of the receipt of amendments.*

(54) Title: DEVICE FOR ENHANCING TRANSDERMAL SAMPLING

(57) Abstract

A device (10, 88, 98, 104) for piercing the stratum corneum of a body surface to form pathways through which an agent can be withdrawn. The device comprises: a sheet (6) having a plurality of microblades (4) extending downward therefrom for piercing the stratum corneum, and a collector (26, 90, 106) on the sheet (6) which withdraws the agent through the pathways.

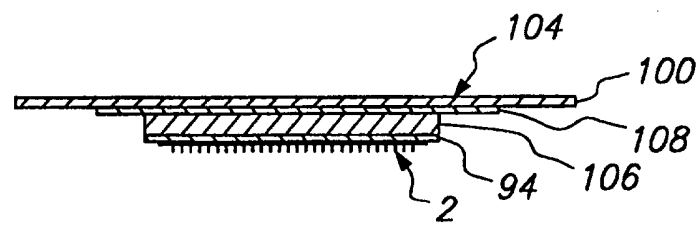

FOR THE PURPOSES OF INFORMATION ONLY

Codes used to identify States party to the PCT on the front pages of pamphlets publishing international applications under the PCT.

AL	Albania	ES	Spain	LS	Lesotho	SI	Slovenia
AM	Armenia	FI	Finland	LT	Lithuania	SK	Slovakia
AT	Austria	FR	France	LU	Luxembourg	SN	Senegal
AU	Australia	GA	Gabon	LV	Latvia	SZ	Swaziland
AZ	Azerbaijan	GB	United Kingdom	MC	Monaco	TD	Chad
BA	Bosnia and Herzegovina	GE	Georgia	MD	Republic of Moldova	TG	Togo
BB	Barbados	GH	Ghana	MG	Madagascar	TJ	Tajikistan
BE	Belgium	GN	Guinea	MK	The former Yugoslav Republic of Macedonia	TM	Turkmenistan
BF	Burkina Faso	GR	Greece	ML	Mali	TR	Turkey
BG	Bulgaria	HU	Hungary	MN	Mongolia	TT	Trinidad and Tobago
BJ	Benin	IE	Ireland	MR	Mauritania	UA	Ukraine
BR	Brazil	IL	Israel	MW	Malawi	UG	Uganda
BY	Belarus	IS	Iceland	MX	Mexico	US	United States of America
CA	Canada	IT	Italy	NE	Niger	UZ	Uzbekistan
CF	Central African Republic	JP	Japan	NL	Netherlands	VN	Viet Nam
CG	Congo	KE	Kenya	NO	Norway	YU	Yugoslavia
CH	Switzerland	KG	Kyrgyzstan	NZ	New Zealand	ZW	Zimbabwe
CI	Côte d'Ivoire	KP	Democratic People's Republic of Korea	PL	Poland		
CM	Cameroon	KR	Republic of Korea	PT	Portugal		
CN	China	KZ	Kazakstan	RO	Romania		
CU	Cuba	LC	Saint Lucia	RU	Russian Federation		
CZ	Czech Republic	LI	Liechtenstein	SD	Sudan		
DE	Germany	LK	Sri Lanka	SE	Sweden		
DK	Denmark	LR	Liberia	SG	Singapore		
EE	Estonia						

1 DEVICE FOR ENHANCING TRANSDERMAL SAMPLING
23 **TECHNICAL FIELD**
4

5 The present invention relates to transdermal agent sampling. More
6 particularly, this invention relates to the transdermal sampling of agents, such
7 as glucose, electrolyte and substances of abuse, such as but not limited to
8 alcohol and illicit drugs. The present invention uses skin-piercing microblades
9 to enhance the transdermal flux of the agents during transdermal sampling.
10

11 **BACKGROUND ART**
12

13 Interest in the percutaneous or transdermal sampling of agents
14 continues to grow. The transdermal sampling of agents still faces significant
15 problems. In many instances, the flux of agents through the skin is insufficient
16 to calculate quickly and accurately the concentration of the substance in the
17 blood or body.

18 One method of increasing the transdermal sampling of agents relies on
19 the application of an electric current across the body surface or on
20 "electrotransport". "Electrotransport" refers generally to the passage of an
21 agent through a body surface such as skin, mucous membranes, nails, and the
22 like. The transport of the agent is induced or enhanced by the application of an
23 electrical potential, which results in the application of electric current, which
24 samples or enhances sampling of the agent. The electrotransport of agents
25 through a body surface may be attained in various manners. One widely used
26 electrotransport process, iontophoresis, involves the electrically induced
27 transport of charged ions. Electroosmosis, another type of electrotransport
28 process, involves the movement of a solvent with the agent through a
29 membrane under the influence of an electric field. Electroporation, still another
30 type of electrotransport, involves the passage of an agent through pores formed
31 by applying a high voltage electrical pulse to a membrane. In many instances,

1 more than one of these processes may be occurring simultaneously to different
2 extents. Further increases in transdermal sampling rates are highly desirable.

3 One method of increasing the agent transdermal sampling rate involves
4 pre-treating the skin with a skin permeation enhancer. The term "permeation
5 enhancer" is broadly used herein to describe a substance which, when applied
6 to a body surface through which the agent is sampled, enhances its
7 transdermal flux. The mechanism may involve an increase in the permeability
8 of the body surface or in the case of electrotransport sampling a reduction of
9 the electrical resistance of the body surface to the passage of the agent
10 therethrough, and/or the creation of hydrophilic pathways through the body
11 surface during electrotransport.

12 There have been many attempts to enhance transdermal flux by
13 mechanically puncturing the skin prior to transdermal drug delivery. See for
14 example U. S. Patent Nos. 5,279,544 issued to Gross et al., 5,250,023 issued
15 to Lee et al., and 3,964,482 issued to Gerstel et al. These devices utilize
16 tubular or cylindrical structures generally, although Gerstel does disclose the
17 use of other shapes, to pierce the outer layer of the skin for agent delivery, but
18 not sampling. Each of these devices provide manufacturing challenges, limited
19 mechanical attachment of the structure to the skin, and/or undesirable irritation
20 of the skin.

21 As has been discussed, a variety of chemicals and mechanical means
22 have been explored to enhance transdermal flux. However, there is still a need
23 to provide a device suitable for increasing transdermal flux which device is low-
24 cost and which can be manufactured reproducibly (i.e., without significant
25 variation from device to device) in high volume production.

DESCRIPTION OF THE INVENTION

1
2
3 The present invention provides a reproducible, high volume production,
4 low-cost device suitable for increasing transdermal flux for agent sampling and
5 monitoring. The invention comprises a plurality of microblades for piercing the
6 skin. The microblades typically have a length of less than about 0.5 mm and a
7 width and thickness which is even smaller. In spite of their small size, the
8 microblades can be made with an extremely reproducible size and shape so
9 that the microslits formed by the microblades puncturing the skin also have a
10 very reproducible size and depth. Because the microblades have a small
11 thickness (i.e., small relative to the width and length of the blades), the
12 microblades produce less tissue damage for a given cross-section than a skin
13 piercing microneedle having a circular cross-section. The device of the present
14 invention pierces the stratum corneum of a body surface to form pathways
15 through which an agent (e.g., a body electrolyte) can be withdrawn (i.e.,
16 sampled or monitored).

17 In one aspect of the invention, the device comprises a sheet having a
18 plurality of microblades integral therewith and extending downward therefrom
19 and a collector on the sheet which collects an agent which is withdrawn through
20 the pathways in the skin formed by the microblades. The device of the present
21 invention can be used in connection with body analyte or drug sampling, or
22 both. Collectors (i.e., sampling devices) for use with the present invention
23 include, but are not limited to, "reverse" electrotransport devices as disclosed in
24 Glikfeld et al., U.S. Patent No. 5,279,543 and Guy et al., U.S. Patent No.
25 5,362,307, passive diffusion devices as disclosed in Schoendorfer for U.S.
26 Patent No. 5,438,984, osmotic devices as disclosed in Eckenhoff et al., U.S.
27 Patent No. 4,756,314 and negative pressure driven devices.

1

BRIEF DESCRIPTION OF THE DRAWINGS

2

3 Figure 1 is a diagrammatic cross-sectional view of a sampling system in
4 accordance with one embodiment of the present invention;

5 Figure 2 is an enlarged perspective view of the skin proximal side of the
6 micro blade array device which may be used in the present invention;

7 Figure 3 is a diagrammatic representation of a method for producing a
8 micro blade array used in the present invention;

9 Figure 4 is a diagrammatic cross-sectional view of a passive agent
10 sampling system in accordance with one embodiment of the present invention;

11 Figure 5 is a diagrammatic cross-sectional view of another embodiment
12 of a passive agent sampling system in accordance with the present invention;

13 Figure 6 is a perspective exploded view of one embodiment of a
14 "reverse" electrotransport agent sampling system with a blade array device
15 according to one embodiment of the present invention;

16 Figure 7 is a bottom plan view of the "reverse" electrotransport agent
17 sampling system of figure 6;

18 Figure 8 is a right side elevational view of the "reverse" electrotransport
19 agent sampling system of figure 6;

20 Figure 9 is a rear elevational view of the "reverse" electrotransport agent
21 sampling system of figure 6; and

22 Figure 10 is a cross-sectional view taken along line 10-10 of the
23 assembled "reverse" electrotransport agent sampling system of figure 8;

24

25

MODES FOR CARRYING OUT THE INVENTION

26

27 Turning now to the drawings in detail, one embodiment of a sampling
28 device of the present invention is generally shown in Figure 1. Figure 1
29 illustrates an osmotic collector or sampling device 104 in combination with a
30 skin-piercing microblade array member 2. The osmotic collector 104 is
31 attached to a body surface by means of an impermeable flexible adhesive

1 overlay 100. Collector 104 is comprised of an absorbent pad (which is
2 impregnated with an osmotically active material such as a highly soluble salt)
3 106 located between a semi-permeable or osmotic membrane 94 and an
4 optional agent sensing element 108. The semi-permeable member 94 is
5 permeable to water and the agent to be collected and impermeable to the
6 osmotically active material. Any of a wide variety of natural and synthetic semi-
7 permeable membranes are known in the art as osmotic membranes. Suitable
8 membranes are enumerated in U.S. Patent Nos. 3,845,770, 3,916,899,
9 4,077,407 and 4,014,334, all of which are incorporated herein by reference.

10 The pad 106 has preferably dispersed therethrough sufficient
11 undissolved osmotic agent such that the concentration of the solution formed
12 within the collection pad as a result of the imbibition of water through the semi-
13 permeable membrane 94 will be maintained at the saturation level throughout
14 the intended sampling period. The pad 106 may also contain dispersed
15 therethrough a collecting material such as colloidal silica, ion exchange resins,
16 activated charcoal or other materials that selectively adhere to the agent being
17 collected to prevent back diffusion of the agent through the membrane 94.

18 The optional agent sensing element can be any of a variety of
19 chemically reactive sensors and indicators, for example the color indicating test
20 strips associated with glucose testing. The adhesive overlay 100 can have a
21 cut-out or transparent window in the area of the indicators so that the indicators
22 can be readily viewed. In an alternate embodiment, the agent sensing element
23 can be located between the member 2 and the pad 106. Alternatively, pad 106
24 and osmotic membrane 94 are combined in one layer of absorbent hydrogel
25 that stores the absorbed fluid as well as the agent. Preferably, the pad 106 is
26 free to expand or is encapsulated in the semi-permeable or osmotic membrane
27 94 so that it retains the fluid therein.

28 Member 2 is used in conjunction with the percutaneous sampling of an
29 agent. The term "sampling" is used broadly herein to include withdrawal of or
30 monitoring the presence or amount of an agent. The terms "substance" and
31 "agent" are used interchangeably herein and broadly include substances such

1 as glucose, body electrolytes, alcohol, illicit drugs, licit substances,
2 pharmaceuticals, blood gases, etc. that can be sampled through the skin. The
3 major barrier properties of the skin, such as resistance to agent passage, reside
4 with the outer most layer (i.e., stratum corneum). The inner division of the
5 epidermis generally comprises three layers commonly identified as stratum
6 granulosum, stratum malpighii, and stratum germinativum. There is essentially
7 little or no resistance to movement of an agent through the stratum granulosum,
8 stratum malpighii, and stratum germinativum. The device of the present
9 invention is used to form microslits in the stratum corneum for in situ sampling
10 of an agent.

11 Member 2 comprises a plurality of microblades 4 (i.e., a blade array)
12 extending downward from one surface of a sheet 6 (see Figure 2 in which a
13 portion of member 2 is in an inverted position to show the microblades). The
14 microblades 4 are sized and shaped to penetrate the stratum corneum of the
15 epidermis when pressure is applied to the device but do not penetrate the skin
16 sufficiently to contact the patient's nerve endings. With this configuration, the
17 microblades do not cause a painful sensation or bleeding. The microblades 4
18 form microslits in a body surface to increase the sampling of a substance
19 through the body surface. The term "body surface" as used herein refers
20 generally to the skin, of an animal or human. Placement of the member 2 in
21 conjunction with a sampling system associated therewith on the body surface of
22 a patient allows in situ sampling and monitoring without relying on collecting a
23 blood or sample with a needle and syringe or lance and test strip. In one
24 preferred embodiment, the device is designed to monitor glucose levels in
25 diabetic patients. In the case of agent (e.g., body analyte) sampling, the
26 analyte migrates from the body through the microslits in the stratum corneum
27 which are cut by the microblades 4. The sampled agent may be collected
28 directly from the skin, or the agent may be contained in the interstitial fluid
29 and/or sweat of the patient and the latter fluid can be collected for purposes of
30 sampling the agent.

31 In one embodiment, the opening 8 corresponds to the portion of the

1 sheet 6 occupied by each of the microblades prior to the blades being
2 transpositioned into the downward depending position. In the illustrated
3 embodiment (Figures 2 and 3), the sheet 6 is formed with an opening 8
4 between the microblades 4. The opening 8 corresponds to the portion of the
5 sheet 6 occupied by each of the microblades 4 prior to the microblades being
6 bent into a position which is substantially perpendicular to the plane of sheet 6.
7 The number of openings 8 per device and the number of microblades 4 per
8 device are independent. The device may have only one large opening 8 with a
9 plurality of microblades 4 around the opening. As will be described below, the
10 opening 8 may be covered with an agent-attracting member for enhancing the
11 movement of an agent being sampled past the electrodes and into an agent-
12 collecting reservoir.

13 The microblades 4 are generally formed from a single piece of material
14 (although they need not be) and are sufficiently sharp and long for puncturing at
15 least the stratum corneum of the body surface. In one embodiment, the
16 microblades 4 and the sheet 6 are essentially impermeable or are impermeable
17 to the passage of an agent. The width of each microblade can be any of a
18 range of widths. Usually, the width of the microblade is in the range of about 25
19 mm to 500 mm. The length of the microblades is subject to variation of the body
20 surface being penetrated and corresponds to the natural thickness of the
21 stratum corneum. Usually, the microblades 4 will be about 20 mm to about 400
22 mm in length. The microblades 4 can have slanted (i.e., angled) leading edges
23 64 (FIG. 2) to further reduce the insertion force required to press the
24 microblades 4 into the body surface. The leading edges 64 of each microblade
25 can be all the same angle or can be at different angles suitable for piercing the
26 body surface. The leading edge can have multiple segments with the distal
27 most segment having a smaller angle with respect to an axis along the length of
28 the microblade than a more proximal segment. Alternatively, the leading edge
29 of each microblade can be arcuate (i.e., curved) in shape, having, for example,
30 a convex or concave shape.

31 The member 2 can also improve the attachment of the device to the

1 body surface so that continuous agent detection through the body surface is
2 preserved during movement of the body surface. In the embodiment shown in
3 FIG. 2, projections in the form of barbs 50 on at least one of the microblades 4
4 assist in anchoring the member 2 and any corresponding device or structure
5 used in combination therewith to the body surface. Barbs 50 can be on any
6 number of the microblades from one to all microblades. The barbs 50 are
7 optional as other means for holding the member in contact with the body
8 surface can be used. The present invention can be used in conjunction with a
9 wide variety of microblades configurations, for example, reference may be had
10 to U.S. Provisional Application No. 60/019,990 filed June 18, 1996 of which any
11 of the disclosed configurations can be used with the present invention.

12 The pattern for any of the microblade array members 2 of the present
13 invention can be produced with a photo-etching process. For example,
14 reference may be had to U.S. Provisional Application No. 60/019,990 filed June
15 18, 1996 of which any of the disclosed methods can be used to produce the
16 member 2 of the present invention. A thin sheet 6 of metal such as stainless
17 steel or titanium is etched photo-lithographically with patterns containing skin
18 piercing structures. In general, a thin laminate dry resist or wet resist is applied
19 on the sheet 6 which typically has a thickness of about 7 μm to about 100 μm ,
20 preferably about 25 μm to about 50 μm . The resist is contact exposed using a
21 mask having the desired pattern and is subsequently developed. These
22 operations are conducted in much the same way that they are for the
23 manufacture of a printed circuit board. The sheet 6 is then etched using acidic
24 solutions. After the pattern has been etched through the sheet, the sheet 6 is
25 placed on a die 52 (Figure 3) having a plurality of openings 56 corresponding to
26 the openings 8 in the sheet. A punch 54 having a plurality of protrusions 58
27 corresponding to the openings 8 in the sheet 6 and openings 56 in the die 52 is
28 initially located above the sheet 6 and the die 52. At the initial stage, the
29 microblades 4 are in the same plane as the rest of the sheet 6. The punch
30 protrusions 58 are then pressed into the openings 8, thus bending the
31 microblades downward to be substantially perpendicular to the plane of the

1 sheet 6. The finished structure provides microblades 4 with an adjacent
2 opening 8. In one embodiment, the opening 8 allows the passage of interstitial
3 fluid therethrough when the member 2 is applied to the body surface.
4 Rectangular openings 8 are shown in the figures but the invention
5 encompasses the use of any shape openings including, but not limited to,
6 square, triangular, circular and elliptical.

7 Generally, the microblades 4 are at an angle of about 90° to the surface
8 48 (FIG. 2) of the sheet 6 after being punched, but they can be disposed at any
9 angle forward or backward from the perpendicular position that will facilitate
10 penetration of and attachment to the body surface. In addition, other anchoring
11 elements such as barbs, openings, etc. can be used with the angled
12 microblades to further enhance anchoring of the device.

13 The member 2 can optionally be made to adhere to the patient's body
14 surface by various means, including an adhesive applied to the body-contacting
15 side of sheet 6 or other anchoring elements on the member 2 of any of the
16 embodiments discussed herein. Further, a watch band or elastic bandage can
17 be used to maintain the device in contact with the skin. The adhesive should
18 have sufficient tack to insure that the member 2 remains in place on the body
19 surface during normal user activity, and yet permits reasonable removal after
20 the predetermined (e.g., 24-hour) wear period. A suitable release liner (not
21 shown) is preferably provided for maintaining the integrity of the adhesive
22 before use. In use, the release liner is stripped from the adhesive before the
23 device is applied to the skin.

24 As is best shown in Figure 2, the microblades 4 have a thickness which
25 is much smaller than the width of the blades near their base, i.e., near the point
26 where the blades are attached to the sheet 6. This blade geometry provides
27 maximum drug percolation area with a minimum blade penetration area, and
28 hence less tissue damage. The agent percolation area is the area of the micro
29 slit opening(s) formed in the stratum corneum by the blade(s), less the cross-
30 sectional area of the blade(s). The microblades are shaped with the largest
31 possible surface area with a minimal cross-sectional area so as to give the

1 largest possible percolation area. Thin microblades are better than round
2 protrusions for this purpose because for the same cross-section, a thin blade
3 produces more percolation area and less tissue damage than a round
4 protrusion. This is a crucial advantage over the prior art round elements such
5 as needles and tubes. Thin microblades also require less insertion force than
6 round protrusions. The width of each blade can be any of a range of widths.
7 The widths can be different from blade to blade in the array pattern. Likewise,
8 the width can be variable along the length of the blade, as will be described in
9 more detail below. The width of the blade at the intersection of the blade and
10 the body surface after the blade array has been inserted is preferably in the
11 range of about 25 mm to about 500 mm, more preferably about 50 mm to about
12 400 mm, more preferably 100 mm to about 300 mm.

13 The sheet 6 and microblades 4 can be made from materials that have
14 sufficient strength and manufacturability to produce blades, such as, glasses,
15 ceramics, rigid polymers, metals and metal alloys. Examples of metals and
16 metal alloys include but are not limited to stainless steel, iron, steel, tin, zinc,
17 copper, platinum, aluminum, germanium, nickel, zirconium, titanium and
18 titanium alloys consisting of nickel, molybdenum and chromium, metals plated
19 with nickel, gold, rhodium, iridium, titanium, platinum, and the like. An example
20 of glasses include a devitrified glass such as "PHOTOCERAM" available from
21 Corning in Corning, NY. Examples of polymers include but are not limited to
22 rigid polymers such as polystyrene, polymethylmethacrylate, polypropylene,
23 polyethylene, "BAKELITE", cellulose acetate, ethyl cellulose,
24 styrene/acrylonitrile copolymers, styrene/butadiene copolymers,
25 acrylonitrile/butadiene/styrene (ABS) copolymers, polyvinyl chloride and acrylic
26 acid polymers including polyacrylates and polymethacrylates.

27 The number of microblades 4 and openings 8 of any of the
28 embodiments of the member 2 is variable with respect to the desired flux rate,
29 agent being sampled, sampling device used (i.e., reverse electrotransport,
30 passive diffusion, osmotic, suction, etc.), and other factors as will be evident to
31 one of ordinary skill in the art. In general, the larger the number of blades per

1 unit area (i.e., the blade density), the more distributed is the flux of the agent
2 through the skin because there are a greater number of agent-conveying
3 pathways through the skin. Consequently, the smaller the number of blades
4 per unit area, the more concentrated is the flux of the agent through the skin
5 because there are fewer pathways. The present invention has a blade density
6 of at least about 10 blades/cm² and less than about 1000 blades/cm²,
7 preferably at least about 600 blades/cm², more preferably at least about 800
8 blades/cm². In similar fashion, the number of openings per unit area through
9 which the agent passes is at least about 10 openings/cm² and less than about
10 1000 openings/cm². In one embodiment, the present invention produces a
11 percolation area of about 0.005 to .05 cm²/cm² of body surface, preferably
12 about 0.01 cm²/cm² of body surface.

13 In other embodiments of the present invention, passive transdermal
14 sampling devices are used with member 2. Two examples of passive
15 transdermal sampling devices are illustrated in Figures 4 and 5. In Figure 4,
16 passive transdermal sampling device 88 comprises a reservoir 90 sandwiched
17 between a backing layer 92, which is preferably impermeable to the agent, and
18 a wicking membrane 94. In Figure 4, the reservoir 90 is formed of a material,
19 such as a rubbery polymer, that is sufficiently viscous to maintain its shape. If a
20 lower viscosity material is used for reservoir 90, such as an aqueous gel,
21 backing layer 92 and wicking membrane 94 would be sealed together about
22 their periphery to prevent leakage. Located below membrane 94 is microblade
23 array member 2. The device 88 adheres to a body surface by means of
24 contact adhesive layer 96 around the periphery of the member 2. A strippable
25 release liner (not shown) is normally provided along the exposed surface of
26 adhesive layer 96 and is removed prior to application of device 88 to the body
27 surface.

28 Alternatively, as shown in Figure 5, transdermal sampling device 98 may
29 be attached to a body surface by means of a flexible adhesive overlay 100.
30 Device 98 is comprised of an impermeable backing layer 102 adjacent one
31 surface of reservoir 90. Adhesive overlay 100 maintains the device 98 on the

1 body surface. Adhesive overlay 100 can be fabricated together with, or
2 provided separately from, the remaining elements of the device 98. With
3 certain formulations, the adhesive overlay 100 may be preferable to the contact
4 adhesive 96 shown in Figure 4. This is true, for example, where the agent
5 reservoir contains a material (such as, for example, an oily surfactant
6 permeation enhancer) which adversely affects the adhesive properties of the
7 contact adhesive layer 96. Impermeable backing layer 102 is preferably slightly
8 larger than reservoir 90, and in this manner prevents the agent collected in
9 reservoir 90 from adversely interacting with the adhesive in overlay 100. A
10 wicking membrane (not shown in Figure 5) similar to membrane 94 in device 88
11 (Figure 4) is located on the skin/mucosa side of reservoir 90. A strippable
12 release liner (not shown) is also normally provided with device 98 and is
13 removed just prior to application of device 98 to the body surface.

14 One embodiment of the present invention relies on the application of an
15 electric current across the body surface or "electrotransport". Electrotransport
16 refers generally to the passage of an agent through a body surface such as
17 skin, mucous membranes, nails, and the like. The transport of the agent is
18 induced or enhanced by the application of an electrical potential, which results
19 in the application of electric current, which for "reverse" electrotransport,
20 samples or enhances sampling of the agent. The electrotransport of the agents
21 out of the skin may be attained in various manners. One widely used
22 electrotransport process, iontophoresis, involves the electrically induced
23 transport of charged ions. Electroosmosis, another type of electrotransport
24 process involved in the transdermal transport of uncharged or neutrally charged
25 molecules (e.g., transdermal sampling of glucose), involves the movement of a
26 solvent with the agent through a membrane under the influence of an electric
27 field. Electroporation, still another type of electrotransport, involves the
28 passage of an agent through pores formed by applying an electrical pulse, a
29 high voltage pulse, to the skin. In many instances, more than one of these
30 processes may be occurring simultaneously to different extents. Accordingly,
31 the term "electrotransport" is given herein its broadest possible interpretation, to

1 include the electrically induced or enhanced transport of at least one charged or
2 uncharged agent, or mixtures thereof, regardless of the specific mechanism(s)
3 by which the agent is actually being transported.

4 It will be appreciated by those working in the field that the present
5 invention can be used in conjunction with a wide variety of electrotransport
6 systems, as the invention is not limited in any way in this regard. For examples
7 of electrotransport drug sampling systems, reference may be had to U.S.
8 Patent Nos. 5,279,543 to Glikfeld et al. and 5,362,307 to Guy et al., the
9 disclosures of which are incorporated by reference herein in their entirety.

10 Electrotransport devices generally use at least two electrodes which are
11 in electrical contact with some portion of the skin, nails, mucous membranes, or
12 other body surface. In the case of transdermal agent sampling, one of the two
13 electrodes is referred to as the "receptor" electrode, and is the one into which
14 the agent (e.g., body analyte) is collected after being withdrawn from the body.
15 The second electrode is typically termed the "counter" or "return" electrode, and
16 serves to close the electrical circuit through the body. For example, when the
17 agent to be sampled is a cation, the cathode becomes the receptor electrode
18 while the anode serves to complete the circuit. When the agent to be sampled
19 is an anion, the anode becomes the receptor electrode while the cathode
20 serves to complete the circuit. When the agent to be sampled has no net
21 charge (e.g., glucose), then either the anode or the cathode, or both electrodes,
22 can serve as the receptor electrode.

23 Figures 6-10 illustrate a representative reverse electrotransport sampling
24 device 10 that may be used in conjunction with the present invention. Device
25 10 comprises an upper housing 16, a circuit board assembly 18, a lower
26 housing 20, first electrode 22, second electrode 24, electrically conductive gel
27 reservoir 26, electrically conductive gel reservoir 28 and skin-compatible
28 adhesive 30. Upper housing 16 has lateral wings 15 which assist in holding
29 device 10 on a patient's skin. Printed circuit board assembly 18 comprises an
30 integrated circuit 19 coupled to discrete components 40 and battery 32. Circuit
31 board assembly 18 is attached to housing 16 by posts (not shown in Figure 1)

1 passing through openings 13a and 13b, the ends of the posts being
2 heated/melted in order to heat stake the circuit board assembly 18 to the
3 housing 16. Lower housing 20 is attached to the upper housing 16 by means
4 of adhesive layer 30, the upper surface 34 of adhesive layer 30 being adhered
5 to both lower housing 20 and upper housing 16 including the bottom surfaces
6 of wings 15. Shown (partially) on the underside of circuit board assembly 18 is
7 a button cell battery 32. Other types of batteries may also be employed to
8 power device 10 depending on the need.

9 The device 10 is generally comprised of battery 32, electronic circuitry
10 19,40, electrodes 22,24, conductive gel reservoirs 26,28, and device 2, all of
11 which are integrated into a self-contained unit. The outputs (not shown in
12 Figure 1) of the circuit board assembly 18 make electrical contact with the
13 electrodes 24 and 22 through openings 23,23' in the depressions 25,25' formed
14 in lower housing 20, by means of electrically conductive adhesive strips 42,42'.

15 Electrodes 22 and 24, in turn, are in direct mechanical and electrical contact
16 with the top sides 44',44 of conductive gel reservoirs 26 and 28. The bottom
17 side 46 of conductive gel reservoir 28 contacts the patient's skin through the
18 opening 29 in adhesive layer 30. The bottom side 46' of conductive gel
19 reservoir 26 contacts the patient's skin through the plurality of openings 8 in the
20 device 2. The gel in reservoir 26 is preferably a viscous gel that fills the
21 openings 8 such that the gel is in contact with the skin when the blades have
22 penetrated the stratum corneum. The contact between the gel and skin
23 provides a path for the agent to be transported along. If the gel is not in direct
24 contact with the skin initially, typically sweat accumulates in the confined area
25 and provides a path for the transport of agent from the skin.

26 Device 10 optionally has a feature which allows the patient to
27 self-administer a sampling or monitoring sequence. Upon depression of push
28 button switch 12, the electronic circuitry on circuit board assembly 18 delivers a
29 predetermined DC current to the electrode/reservoirs 22,26 and 24,28 for a
30 sampling interval of predetermined length. The push button switch 12 is
31 conveniently located on the top side of device 10 and is easily actuated through

1 clothing. A double press of the push button switch 12 within a short time
2 period, e.g., three seconds, is preferably used to activate the device for a
3 sampling or monitoring sequence, thereby minimizing the likelihood of
4 inadvertent actuation of the device 10. Preferably, the device transmits to the
5 user a visual and/or audible confirmation of the onset of the sampling interval
6 by means of LED 14 becoming lit and/or an audible sound signal from, e.g., a
7 "beeper". Agent is withdrawn through the patient's skin, e.g., on the arm, by
8 electrotransport over the predetermined sampling interval.

9 The push button switch 12, the electronic circuitry on circuit board
10 assembly 18 and the battery 32 are adhesively "sealed" between upper
11 housing 16 and lower housing 20. Upper housing 16 is preferably composed of
12 rubber or other elastomeric material, e.g., injection moldable ethylene vinyl
13 acetate. Lower housing 20 is preferably composed of a plastic or elastomeric
14 sheet material (e.g., polyethylene) which can be easily molded to form
15 depressions 25,25' and cut to form openings 23,23'. The assembled device 10
16 is preferably water resistant (i.e., splash proof) and is most preferably
17 waterproof. The system has a low profile that easily conforms to the body,
18 thereby allowing freedom of movement at, and around, the wearing site. The
19 reservoirs 26 and 28 are located on the skin-contacting side of the device 10
20 and are sufficiently separated to prevent accidental electrical shorting during
21 normal handling and use.

22 The device 10 adheres to the patient's body surface (e.g., skin) by
23 means of an adhesive layer 30 (which has upper adhesive side 34 and body-
24 contacting adhesive side 36). The adhesive side 36 covers the entire
25 underneath side of the device 10 except where the device 2 and reservoir 28
26 are located. The adhesive side 36 has adhesive properties which assures that
27 the device 10 remains in place on the body during normal user activity, and yet
28 permits reasonable removal after the predetermined (e.g., 24-hour) wear
29 period. Upper adhesive side 34 adheres to lower housing 20 and retains the
30 electrodes and gel reservoirs within housing depression 25,25' as well as
31 retains device 2 to lower housing 20 and lower housing 20 to upper housing 16.

1 In one embodiment of the sampling device, there is a release liner (not shown)
2 on the device 10 for maintaining the integrity of the device when it is not in use.
3 In use, the release liner is stripped from the device before the device is applied
4 to the skin.

5 The preferred form in which an agent is sampled generally determines
6 the type of sampling system to be used. That is, the selection of a "passive"
7 system which samples the agent by diffusion or an electrically powered system
8 which samples the agent by electrotransport will be mostly determined by the
9 form of the agent. For osmotic systems which sample drugs by convective flow
10 carried by a solvent, the agent preferably has sufficient solubility in the carrier
11 solvent. It will be appreciated by those working in the field that the present
12 invention can be used in conjunction with a wide variety of osmotic sampling
13 systems, as the invention is not limited to a particular device in this regard.
14 Osmotic devices are disclosed for example in U.S. Patent Nos. 4,756,314 to
15 Eckenhoff et al., 4,340,480 to Eckenhoff, 4,655,766 to Theeuwes et al., and
16 4,753,651 to Eckenhoff, the disclosures of which are incorporated by reference
17 herein in their entirety. As mentioned above, the member 2 of the present
18 invention can be used with known sampling devices including, but not limited
19 to, reverse iontophoresis, osmosis, passive diffusion, phonophoresis, and
20 suction (i.e., negative pressure).

21 It will be appreciated by those of ordinary skill in the art that the invention
22 can be embodied in other specific forms without departing from the spirit or
23 essential character thereof. The presently disclosed embodiments are
24 therefore considered in all respects to be illustrative and not restrictive. The
25 scope of the invention is indicated by the appended claims rather than the
26 foregoing description, and all changes which come within the meaning and
27 range of equivalents thereof are intended to be embraced therein.

1 **CLAIMS:**

2

3 1. A device (10,88,98,104) for piercing the stratum corneum of a body
4 surface to form pathways through which an agent can be withdrawn,
5 comprising:

6 a sheet (6) having a plurality of microblades (4) extending downward
7 therefrom; and

8 a collector (26,90,106) on the sheet (6) which withdraws the agent
9 through the pathways.

10

11 2. The device (10,88,98,104) of Claim 1, wherein the collector
12 (26,90,106) is positioned to sample the agent from the body surface through an
13 opening (8) in the sheet.

14

15 3. The device of Claim 1, wherein the collector is a reverse
16 electrotransport device (10).

17

18 4. The device of Claim 1, wherein the collector is a passive diffusion
19 device (88,98).

20

21 5. The device of Claim 1, wherein the collector is an osmotic device
22 (104).

23

24 6. The device of Claim 1, wherein the collector comprises:

25 a semi-permeable membrane (94) positioned across an opening (8) in
26 the sheet (6); and

27 an absorbent pad (106) on the semi-permeable membrane (94).

28

29 7. The device of Claim 6, wherein the absorbent pad (106) contains an
30 osmotically active material.

31

1 8. The device of Claim 1, further comprising an agent sensing element
2 (108).

3

4 9. The device of Claim 8, wherein the agent sensing element (108) is a
5 glucose sensor.

6

1/3

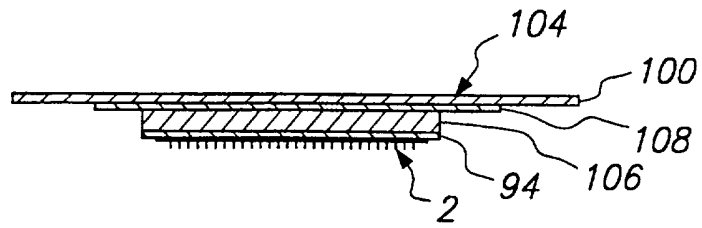

FIG. 1

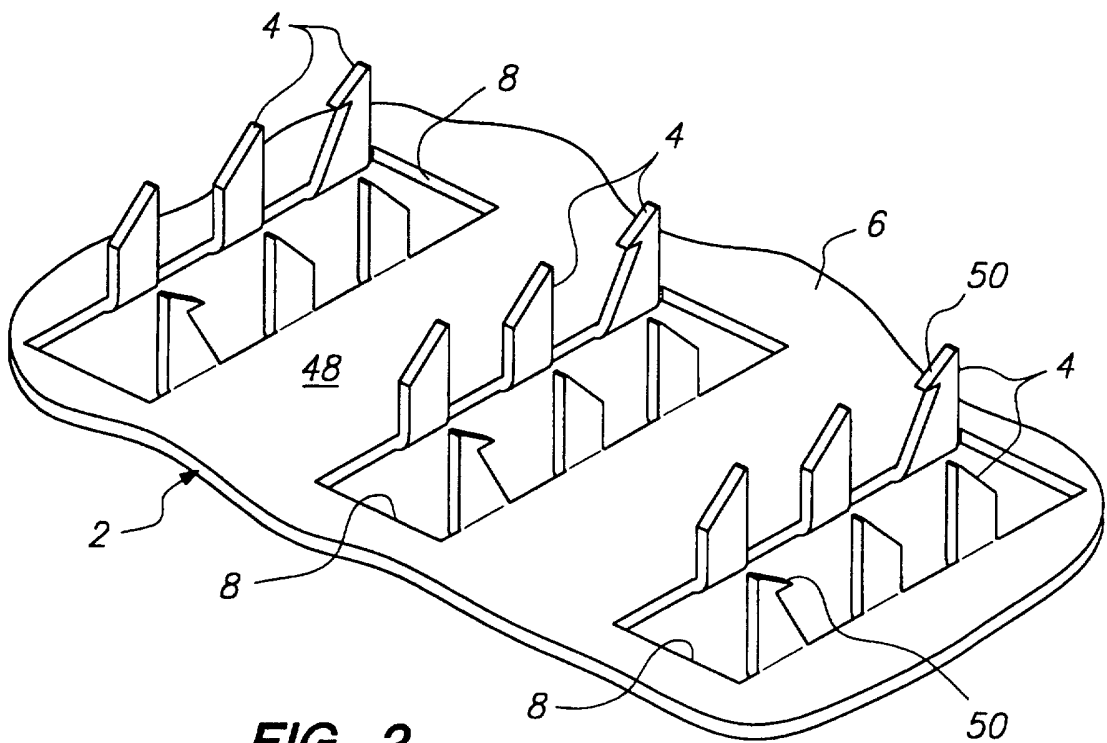

FIG. 2

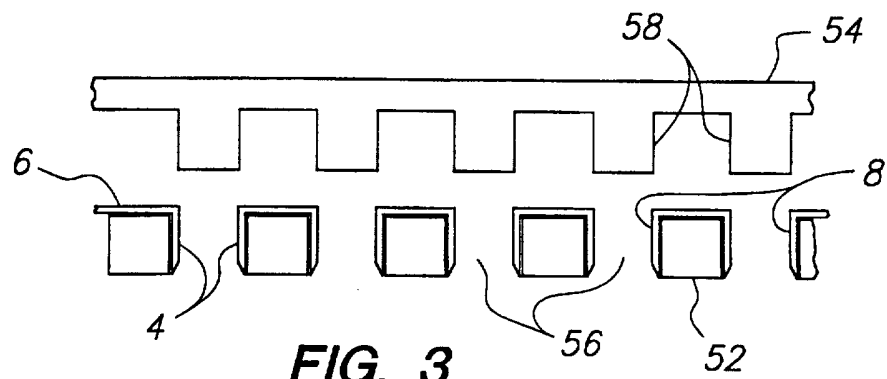

FIG. 3

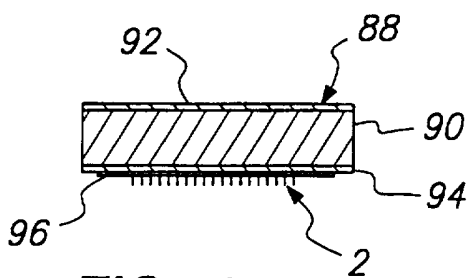

FIG. 4

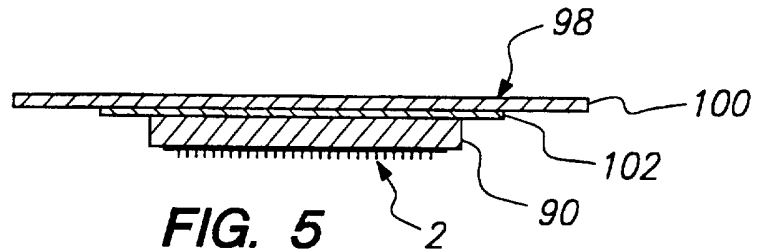

FIG. 5

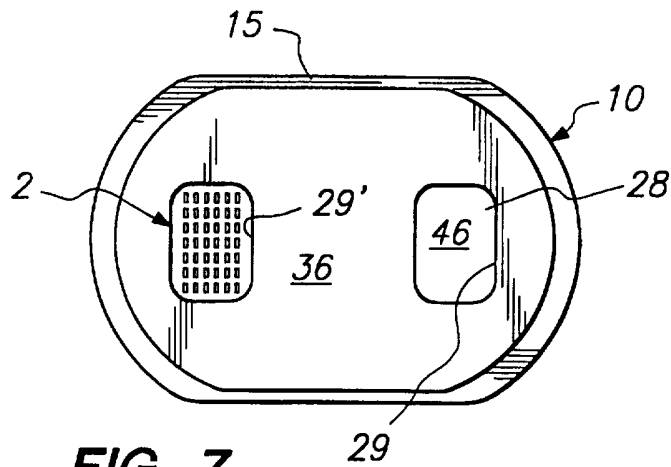

FIG. 7

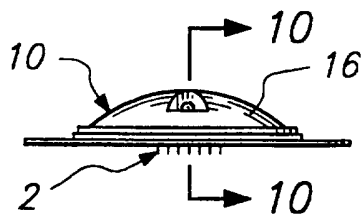

FIG. 8

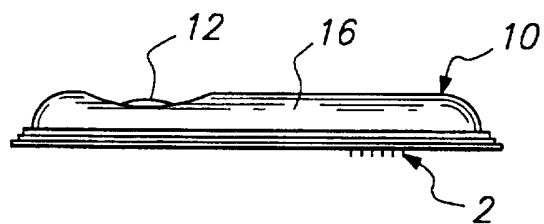

FIG. 9

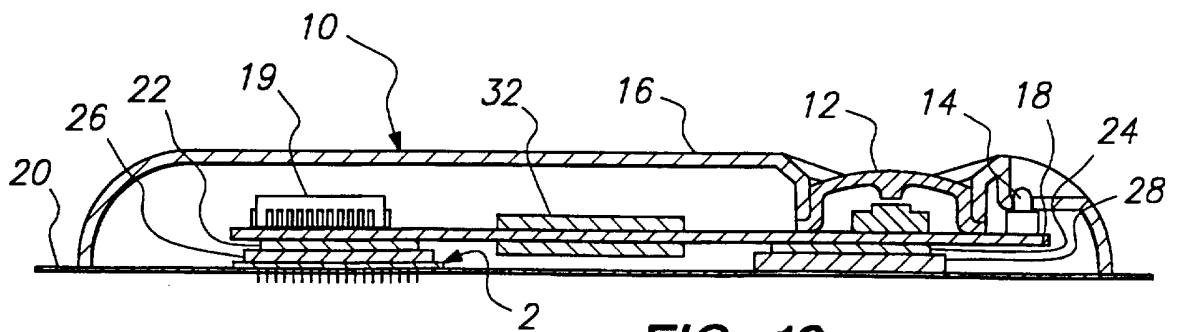
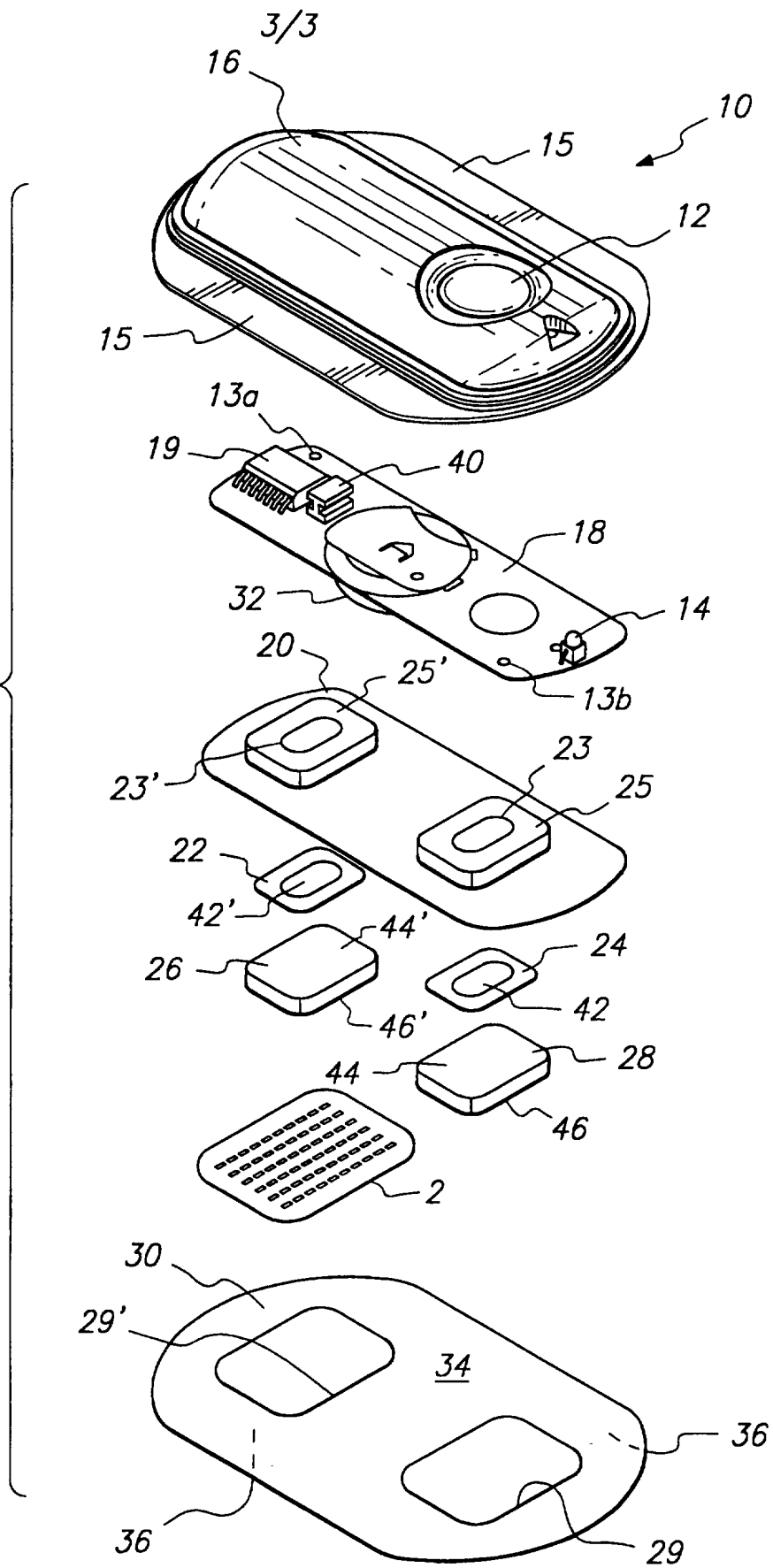

FIG. 10

FIG. 6



INTERNATIONAL SEARCH REPORT

International Application No

PCT/US 97/10595

A. CLASSIFICATION OF SUBJECT MATTER
IPC 6 A61N1/30

According to International Patent Classification (IPC) or to both national classification and IPC

B. FIELDS SEARCHED

Minimum documentation searched (classification system followed by classification symbols)

IPC 6 A61N

Documentation searched other than minimum documentation to the extent that such documents are included in the fields searched

Electronic data base consulted during the international search (name of data base and, where practical, search terms used)

C. DOCUMENTS CONSIDERED TO BE RELEVANT

Category *	Citation of document, with indication, where appropriate, of the relevant passages	Relevant to claim No.
Y	WO 96 00110 A (CYGNUS THERAPEUTIC SYSTEMS) 4 January 1996	1-3,8,9
A	see page 18, line 3 - page 23, line 24; figures	6

Y	WO 96 17648 A (CIBA GEIGY AG ;EFFENHAUSER CARLO STEFAN (DE); MANZ ANDREAS (CH)) 13 June 1996	1-3,8,9
	see page 7, line 28 - page 12, line 27; figures	

A	US 5 279 543 A (GLIKFELD ET AL.) 18 January 1994	1-3
	cited in the application see column 3, line 64 - column 4, line 49; figures 7,8	

	-/--	

Further documents are listed in the continuation of box C.

Patent family members are listed in annex.

* Special categories of cited documents :

- *A* document defining the general state of the art which is not considered to be of particular relevance
- *E* earlier document but published on or after the international filing date
- *L* document which may throw doubts on priority claim(s) or which is cited to establish the publication date of another citation or other special reason (as specified)
- *O* document referring to an oral disclosure, use, exhibition or other means
- *P* document published prior to the international filing date but later than the priority date claimed

- *T* later document published after the international filing date or priority date and not in conflict with the application but cited to understand the principle or theory underlying the invention
- *X* document of particular relevance; the claimed invention cannot be considered novel or cannot be considered to involve an inventive step when the document is taken alone
- *Y* document of particular relevance; the claimed invention cannot be considered to involve an inventive step when the document is combined with one or more other such documents, such combination being obvious to a person skilled in the art.
- *Z* document member of the same patent family

Date of the actual completion of the international search

31 October 1997

Date of mailing of the international search report

10. 11. 97

Name and mailing address of the ISA

European Patent Office, P.B. 5818 Patentlaan 2
NL - 2280 HV Rijswijk
Tel. (+31-70) 340-2040, Tx. 31 651 epo nl,
Fax: (+31-70) 340-3016

Authorized officer

Rakotondrajaona, C

INTERNATIONAL SEARCH REPORT

International Application No
PCT/US 97/10595

C.(Continuation) DOCUMENTS CONSIDERED TO BE RELEVANT		
Category *	Citation of document, with indication, where appropriate, of the relevant passages	Relevant to claim No.
A	US 5 438 984 A (SCHOENDORFER DONALD W) 8 August 1995 cited in the application see column 2, line 44 - column 5, line 16; figures ---	1-3
A	WO 94 05368 A (TACHIBANA KATSURO ;TACHIBANA SHUNRO (JP)) 17 March 1994 see abstract; figures ---	1-3
A	US 5 036 861 A (SEMBROWICH WALTER L ET AL) 6 August 1991 see the whole document -----	1-3,6,8, 9

INTERNATIONAL SEARCH REPORT

Information on patent family members

Intern. Patent Application No

PCT/US 97/10595

Patent document cited in search report	Publication date	Patent family member(s)	Publication date
WO 9600110 A	04-01-96	AU 2944995 A	19-01-96
		CA 2193885 A	04-01-96
		EP 0766578 A	09-04-97

WO 9617648 A	13-06-96	AU 4256496 A	26-06-96
		EP 0796128 A	24-09-97

US 5279543 A	18-01-94	AT 129909 T	15-11-95
		AU 639888 B	12-08-93
		AU 3183889 A	25-08-89
		DE 68924716 D	14-12-95
		DE 68924716 T	04-07-96
		DK 179390 A	28-07-90
		EP 0326398 A	02-08-89
		EP 0673622 A	27-09-95
		ES 2085863 T	16-06-96
		IE 63406 B	19-04-95
		JP 4502561 T	14-05-92
		KR 9711449 B	11-07-97
		PT 89560 B	31-05-95
		WO 8906989 A	10-08-89
		US 5362307 A	08-11-94

US 5438984 A	08-08-95	US 5441048 A	15-08-95
		US 5203327 A	20-04-93
		US 4957108 A	18-09-90
		AU 677036 B	10-04-97
		AU 5951194 A	04-07-94
		CA 2151470 A	23-06-94
		EP 0676051 A	11-10-95
		JP 8504513 T	14-05-96
		WO 9414062 A	23-06-94
		US 5465713 A	14-11-95
		US 5676144 A	14-10-97
		US 5638815 A	17-06-97
		AT 137583 T	15-05-96
		AU 654823 B	24-11-94
		AU 8313791 A	17-03-92
CA 2088921 A	16-02-92		
DE 69119231 D	05-06-96		

INTERNATIONAL SEARCH REPORT

Information on patent family members

International Application No

PCT/US 97/10595

Patent document cited in search report	Publication date	Patent family member(s)	Publication date
US 5438984 A		DE 69119231 T EP 0543867 A JP 6503875 T WO 9203731 A US 5445147 A AT 129868 T DE 68924779 D DE 68924779 T EP 0433382 A JP 4500559 T WO 9002511 A US 5076273 A	21-11-96 02-06-93 28-04-94 05-03-92 29-08-95 15-11-95 14-12-95 05-06-96 26-06-91 30-01-92 22-03-90 31-12-91

WO 9405368 A	17-03-94	JP 6070987 A EP 0625360 A US 5582586 A	15-03-94 23-11-94 10-12-96

US 5036861 A	06-08-91	NONE	
