



US00D833391S

(12) **United States Design Patent** (10) **Patent No.:** **US D833,391 S**
Claeys (45) **Date of Patent:** **** Nov. 13, 2018**

(54) **CURRENT TRANSDUCER**

OTHER PUBLICATIONS

(71) Applicant: **LEM Intellectual Property SA**,
Fribourg (CH)

Notice of Allowance for U.S. Appl. No. 29/626,890 dated May 11, 2018.

(72) Inventor: **Stephane Claeys**, Chevrier (FR)

Primary Examiner — Derrick Holland

(73) Assignee: **LEM INTELLECTUAL PROPERTY SA**, Fribourg (CH)

(74) *Attorney, Agent, or Firm* — Harness, Dickey & Pierce, P.L.C.

(**) Term: **15 Years**

(57) **CLAIM**

(21) Appl. No.: **29/626,885**

The ornamental design for a current transducer, as shown and described.

(22) Filed: **Nov. 21, 2017**

DESCRIPTION

Related U.S. Application Data

(62) Division of application No. 29/516,496, filed on Feb. 3, 2015, now Pat. No. Des. 812,001.

FIG. 1 is a bottom front perspective view of a first embodiment of a current transducer showing my new design; FIG. 2 is a top rear perspective view thereof; FIG. 3 is a front view thereof; FIG. 4 is a rear view thereof; FIG. 5 is a left side View thereof; FIG. 6 is a right side view thereof; FIG. 7 is a top plan view thereof; and FIG. 8 is a bottom plan view thereof.

Foreign Application Priority Data

Aug. 27, 2014 (WO) 835662601

FIG. 9 is a bottom front perspective view of a second embodiment of a current transducer showing my new design;

(51) **LOC (11) Cl.** **13-02**

(52) **U.S. Cl.**
USPC **D13/110**

FIG. 10 is a top rear perspective view thereof;

(58) **Field of Classification Search**
USPC D13/110, 101, 117, 123, 124, 159, 182, D13/184, 199; D10/75; 73/767, 771,
(Continued)

FIG. 11 is a front view thereof;

FIG. 12 is a rear view thereof;

FIG. 13 is a left side View thereof;

FIG. 14 is a right side view thereof;

FIG. 15 is a top plan view thereof; and

FIG. 16 is a bottom plan view thereof.

FIG. 17 is a bottom front perspective view of a third embodiment of a current transducer showing my new design;

FIG. 18 is a top rear perspective view thereof;

FIG. 19 is a front view thereof;

FIG. 20 is a rear view thereof;

FIG. 21 is a left side View thereof;

FIG. 22 is a right side view thereof;

FIG. 23 is a top plan view thereof; and

(Continued)

References Cited

U.S. PATENT DOCUMENTS

D219,597 S * 12/1970 Smith D13/110
D260,635 S * 9/1981 Lockwood D13/110
(Continued)

FOREIGN PATENT DOCUMENTS

CN 03303685.3 8/2003
DM 062779 1/2003
(Continued)

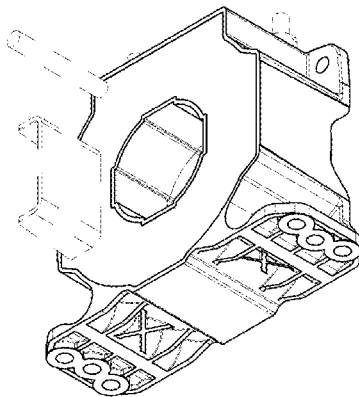

FIG. 24 is a bottom plan view thereof.
 FIG. 25 is a bottom front perspective view of a fourth embodiment of a current transducer showing my new design;
 FIG. 26 is a top rear perspective view thereof;
 FIG. 27 is a front view thereof;
 FIG. 28 is a rear view thereof;
 FIG. 29 is a left side View thereof;
 FIG. 30 is a right side view thereof;
 FIG. 31 is a top plan view thereof; and
 FIG. 32 is a bottom plan view thereof.
 FIG. 33 is a bottom front perspective view of a fifth embodiment of a current transducer showing my new design;
 FIG. 34 is a top rear perspective view thereof;
 FIG. 35 is a front view thereof;
 FIG. 36 is a rear view thereof;
 FIG. 37 is a left side View thereof;
 FIG. 38 is a right side View thereof;
 FIG. 39 is a top plan view thereof; and
 FIG. 40 is a bottom plan view thereof.
 FIG. 41 is a bottom front perspective view of a sixth embodiment of a current transducer showing my new design;
 FIG. 42 is a top rear perspective view thereof;
 FIG. 43 is a front view thereof;
 FIG. 44 is a rear view thereof;
 FIG. 45 is a left side View thereof;
 FIG. 46 is a right side view thereof;
 FIG. 47 is a top plan view thereof; and
 FIG. 48 is a bottom plan view thereof.
 FIG. 49 is a bottom front perspective view of a seventh embodiment of a current transducer showing my new design;
 FIG. 50 is a top rear perspective view thereof;
 FIG. 51 is a front view thereof;
 FIG. 52 is a rear view thereof;
 FIG. 53 is a left side View thereof;
 FIG. 54 is a right side view thereof;
 FIG. 55 is a top plan view thereof; and,
 FIG. 56 is a bottom plan view thereof.

The broken lines depict environmental subject matter only and form no part of the claimed design.

1 Claim, 22 Drawing Sheets

(58) **Field of Classification Search**

USPC 73/779, 801, 811; 324/117 H, 117 R, 324/120, 121 R, 127; 361/18, 30, 31, 361/93.1-93.9; 367/140; 369/13.11-13.13; 381/150; 336/173, 336/176, 178
 CPC H01R 13/5812; G01R 33/06; G01R 15/20; G01R 15/202; G01R 19/18; G01R 19/20; G01R 19/22; G01R 19/0084; G01R 19/0092; G01R 19/00; G01R 5/20; G01R 5/22; G01R 5/24; G01R 5/26

See application file for complete search history.

(56) **References Cited**

U.S. PATENT DOCUMENTS

D260,877 S	9/1981	Scott et al.	
D288,314 S	2/1987	Makinson et al.	
D494,078 S	8/2004	Vuillermoz	
D534,120 S	12/2006	Ricci et al.	
7,598,601 B2	10/2009	Taylor et al.	
D610,087 S	2/2010	Johnson	
D640,986 S *	7/2011	Gong	D13/154
D685,325 S	7/2013	Hayashi	
D685,734 S	7/2013	Sage	
D686,156 S	7/2013	Ye	
D688,626 S	8/2013	Ye	
8,587,399 B2	11/2013	Crutcher et al.	
D751,034 S	3/2016	Ye	
2009/0115403 A1 *	5/2009	Bernklau	G01R 15/186 324/127

FOREIGN PATENT DOCUMENTS

GB	3010841	2/2003
JP	1195975	12/2003
WO	WO-DM-062779	1/2003

* cited by examiner

FIG. 1

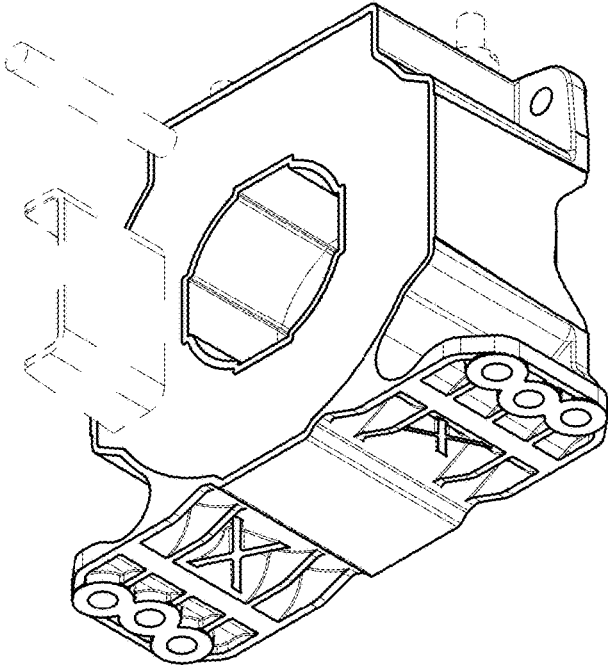

FIG. 2

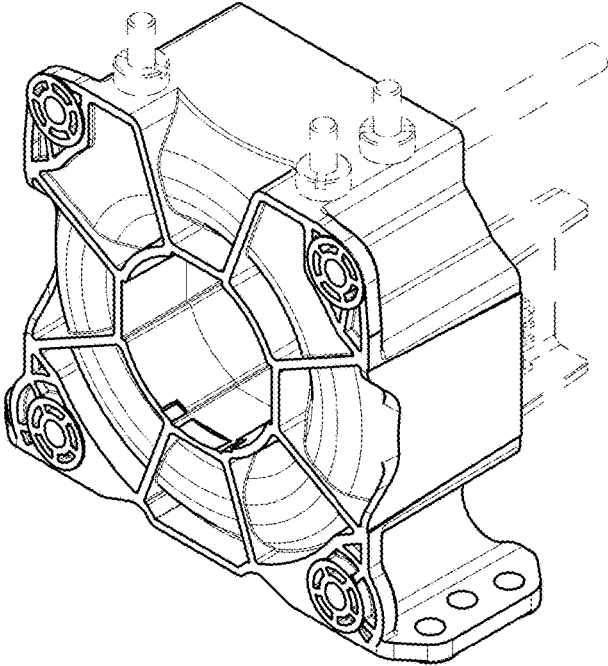

FIG. 3

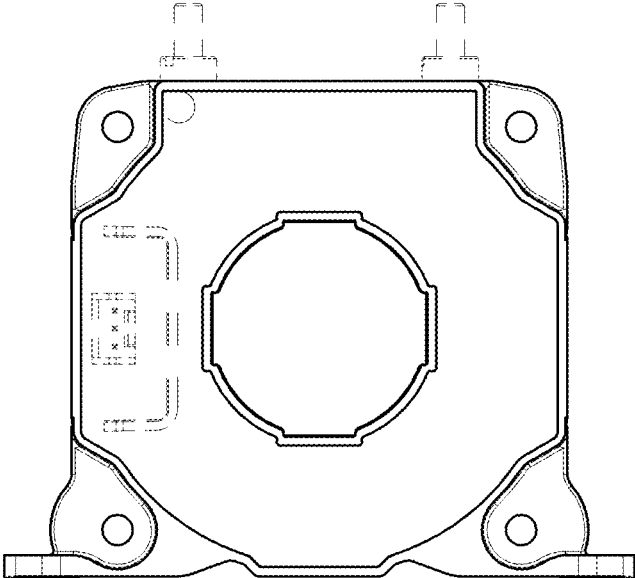

FIG. 4

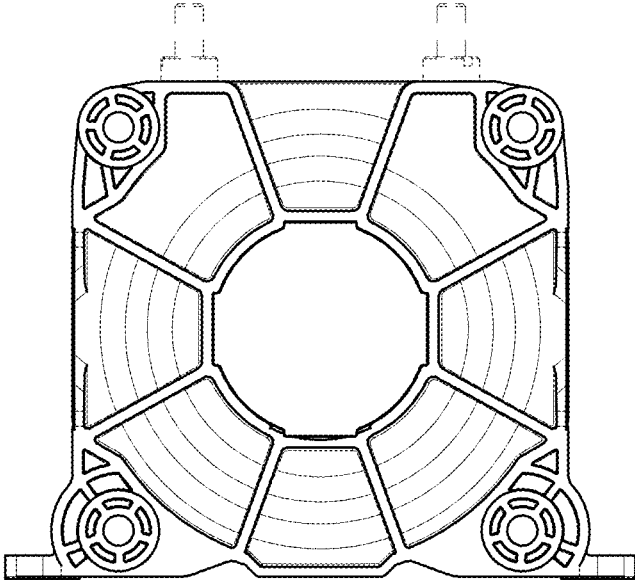

FIG. 5

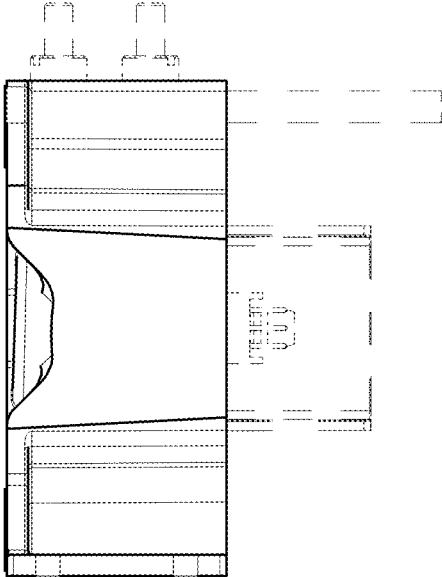
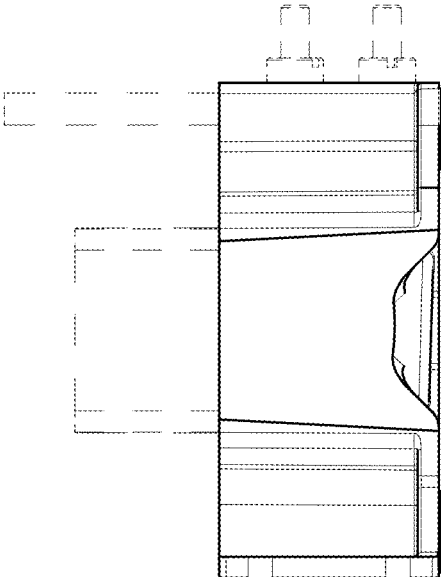

FIG. 6



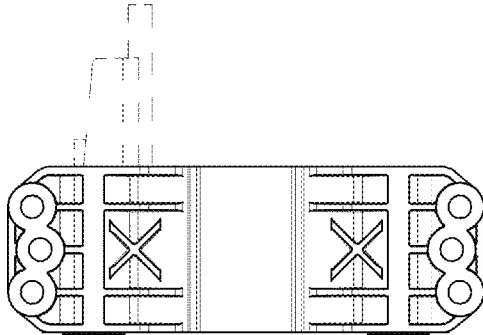
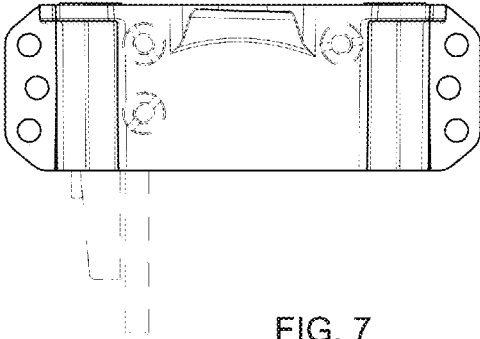

FIG. 9

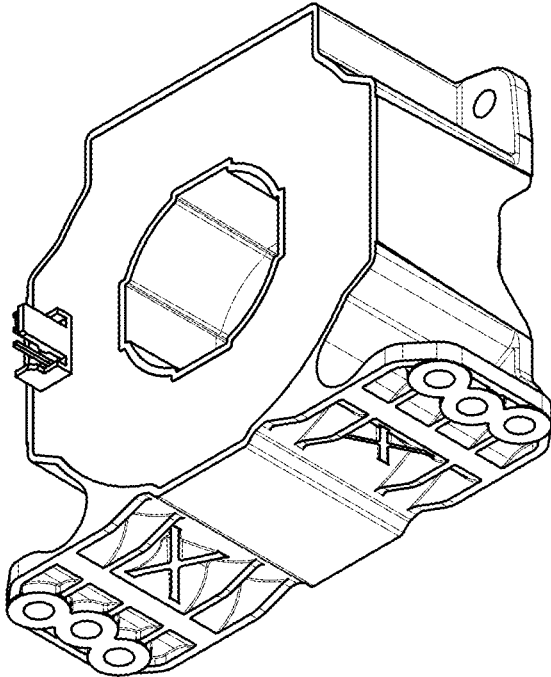

FIG. 10

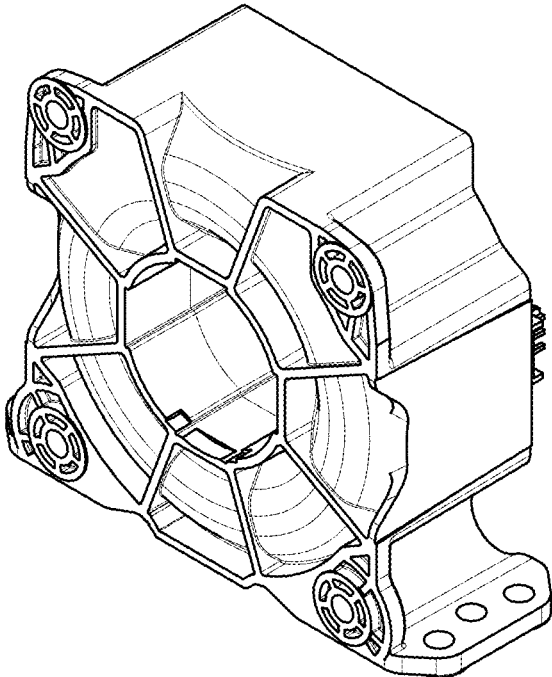

FIG. 11

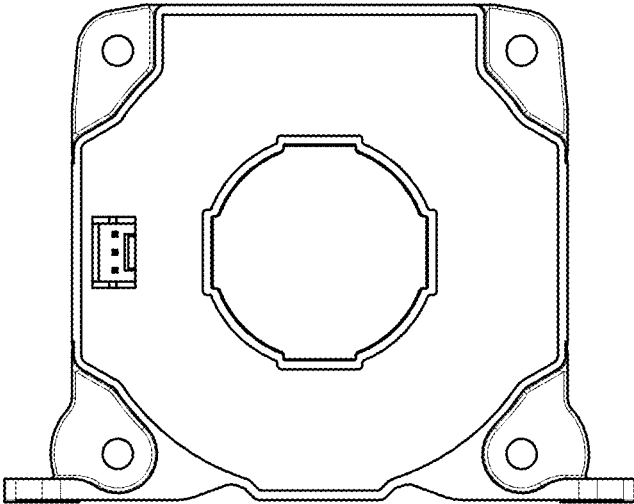
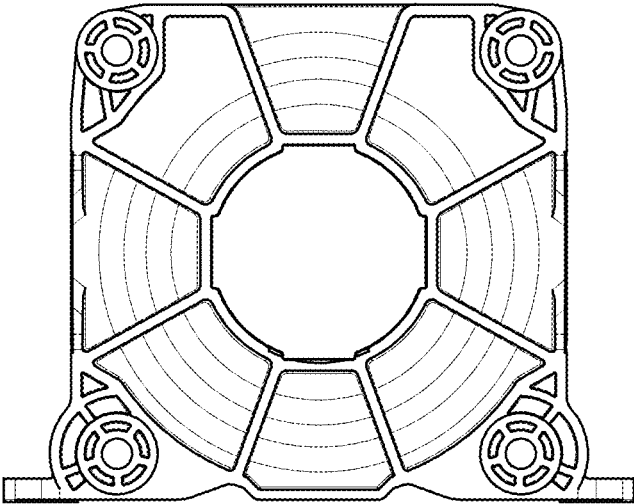

FIG. 12



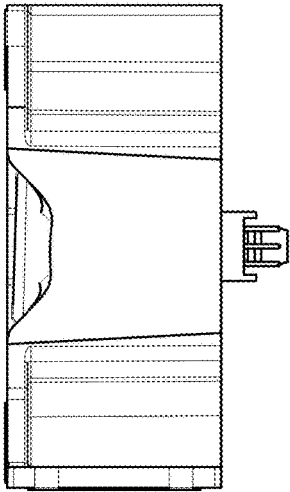

FIG. 13

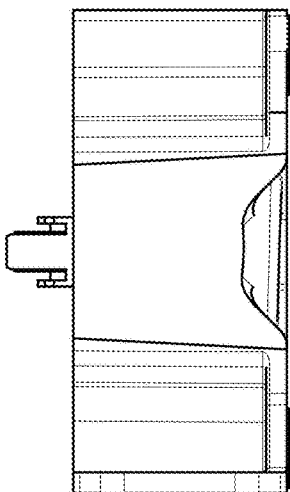

FIG. 14

FIG. 15

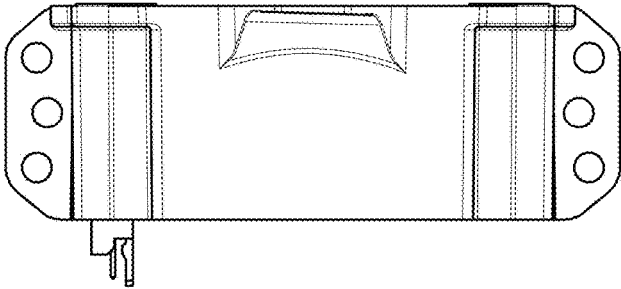

FIG. 16

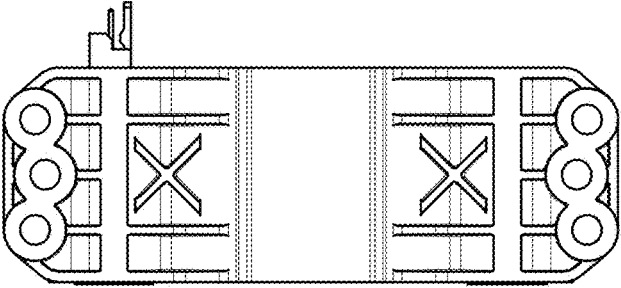

FIG. 17

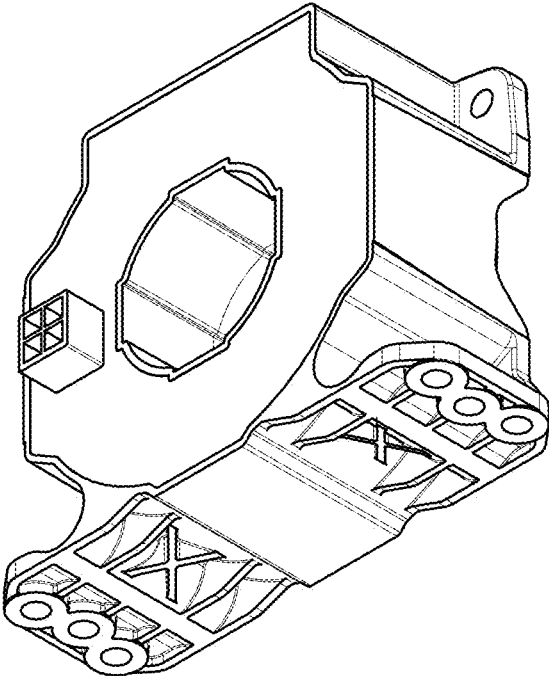

FIG. 18

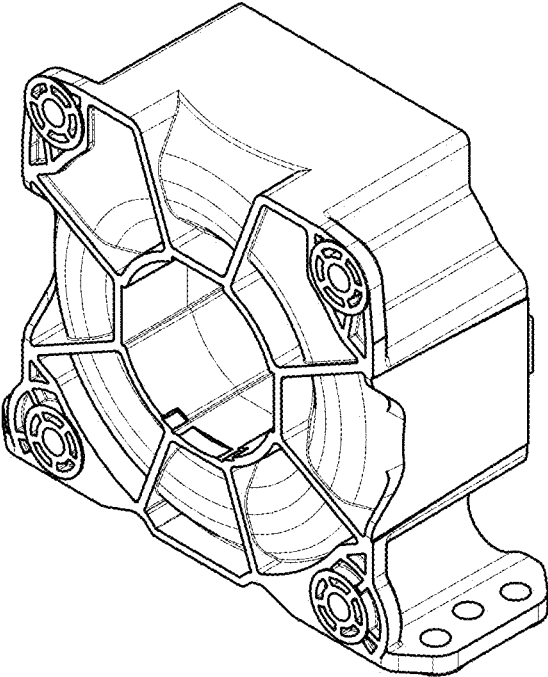

FIG. 19

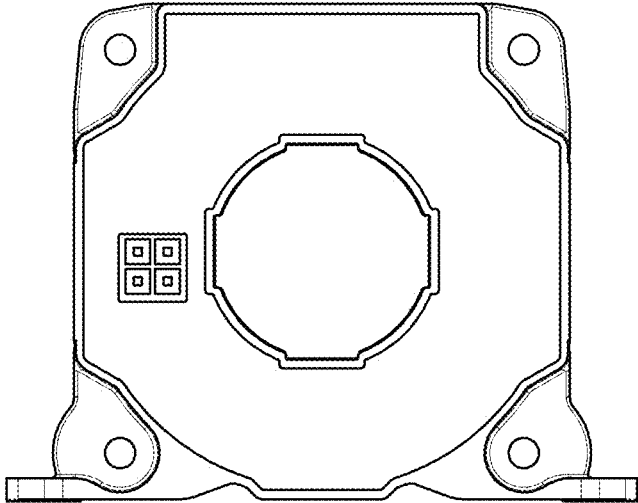
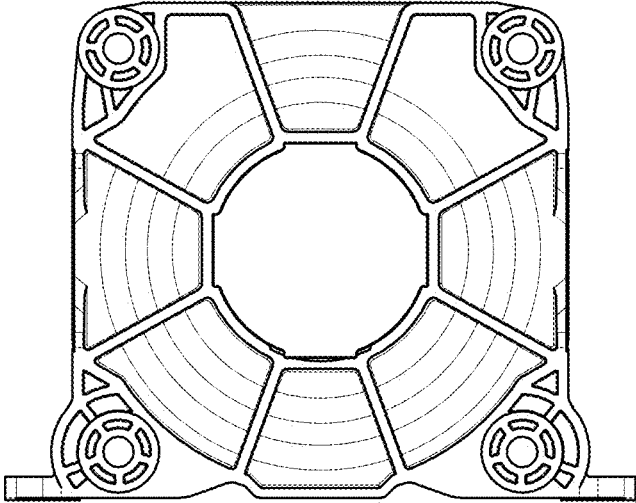

FIG. 20



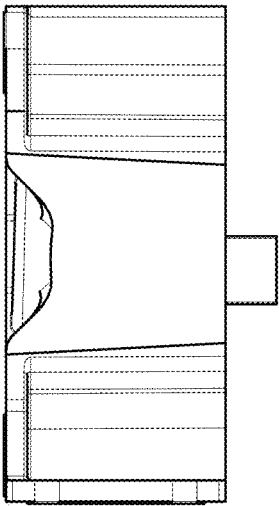

FIG. 21

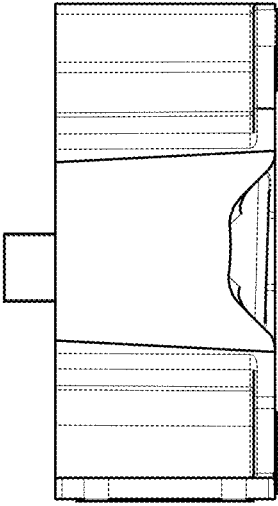

FIG. 22

FIG. 23

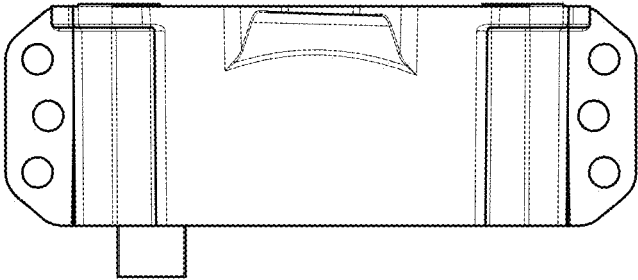

FIG. 24

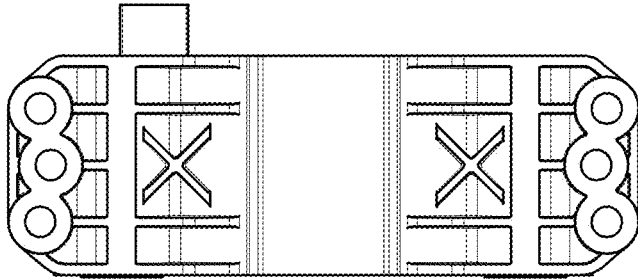

FIG. 25

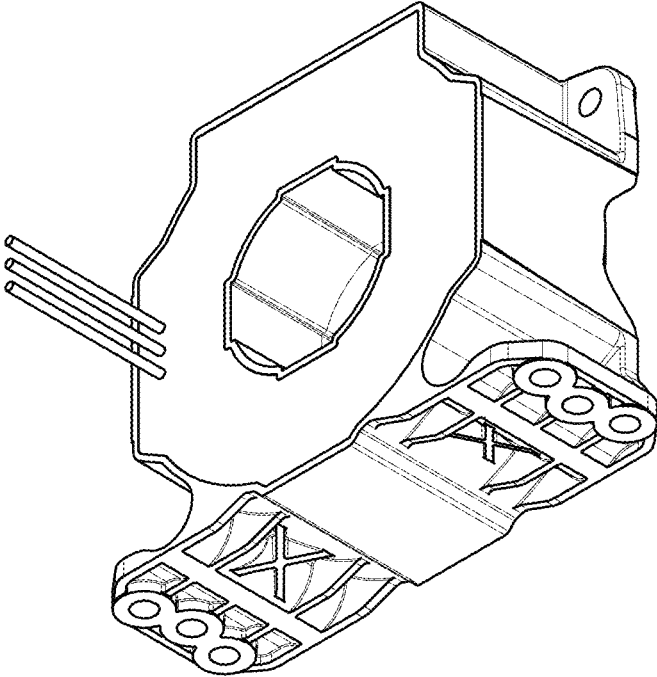

FIG. 26

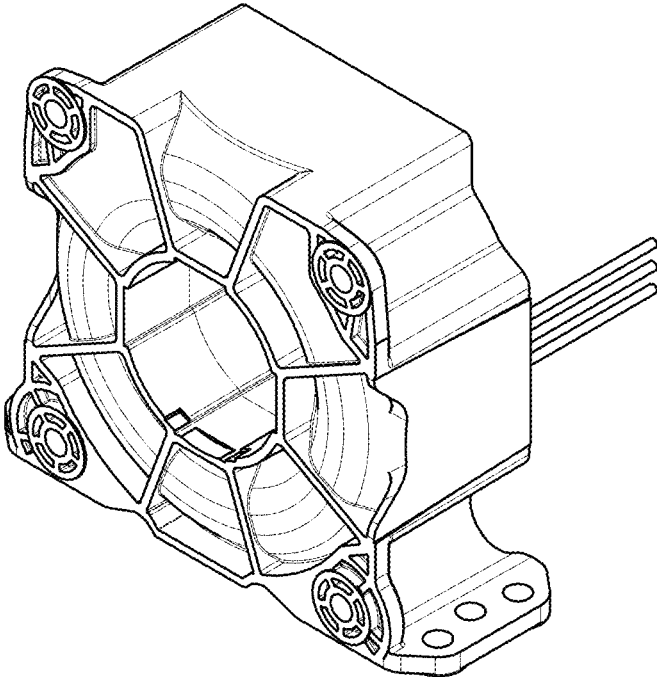

FIG. 27

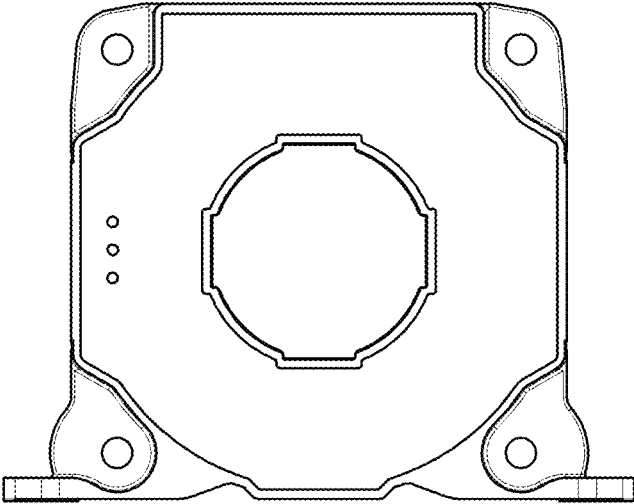
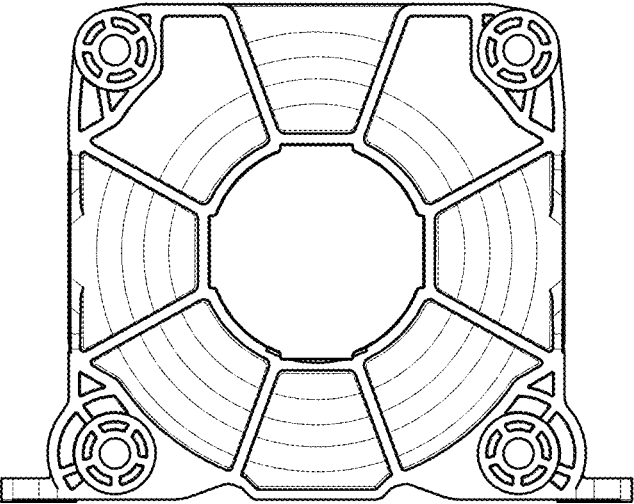

FIG. 28



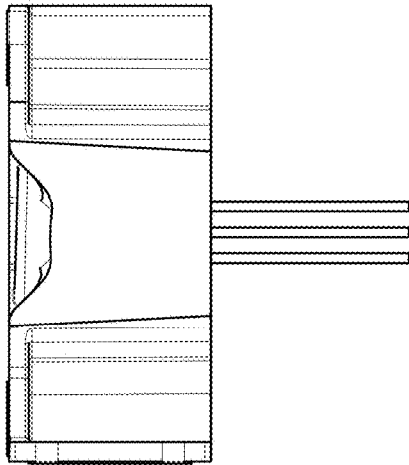

FIG. 29

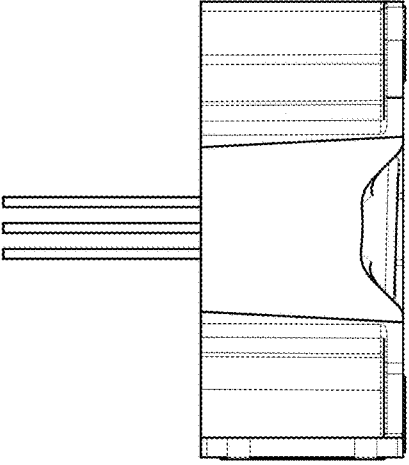

FIG. 30

FIG. 31

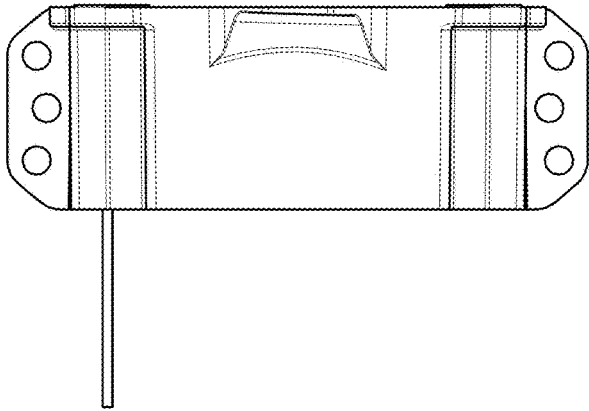

FIG. 32

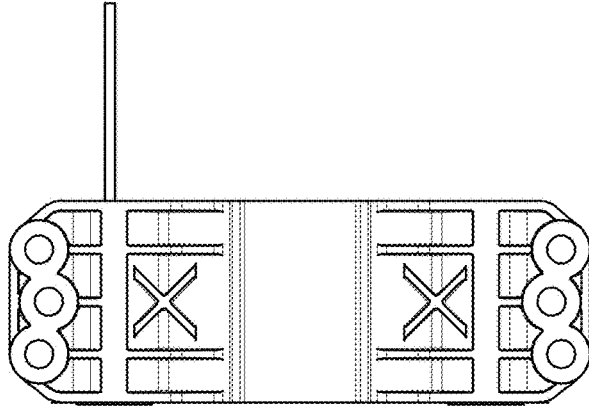

FIG. 33

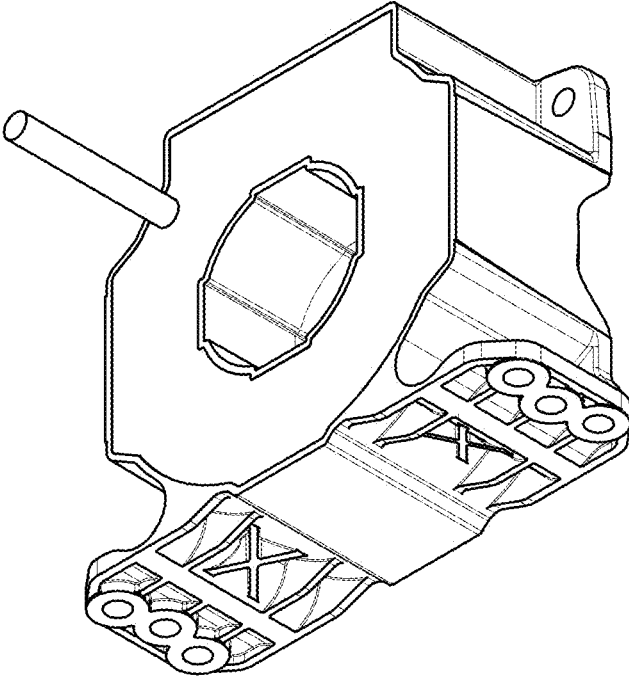

FIG. 34

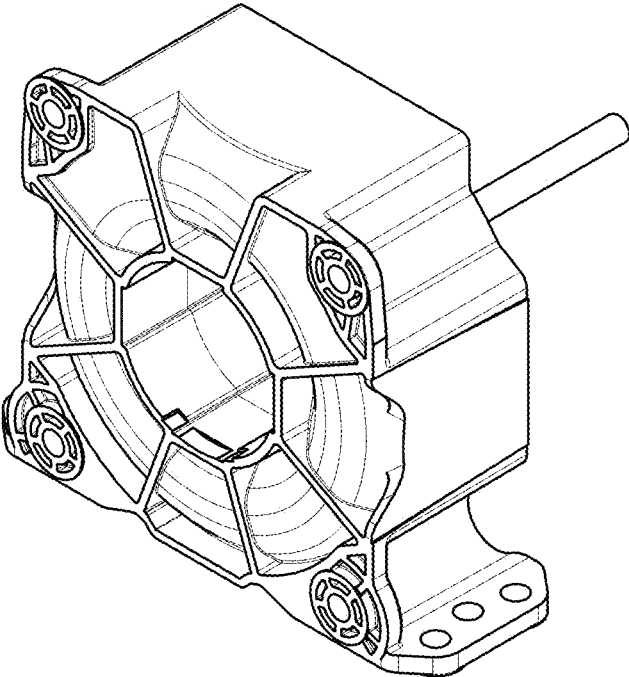

FIG. 35

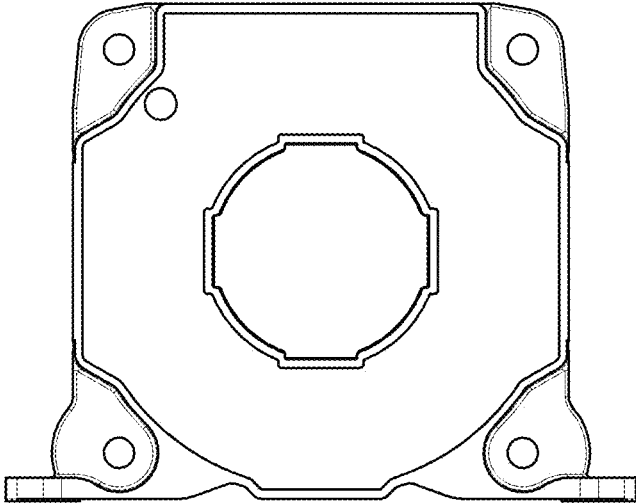
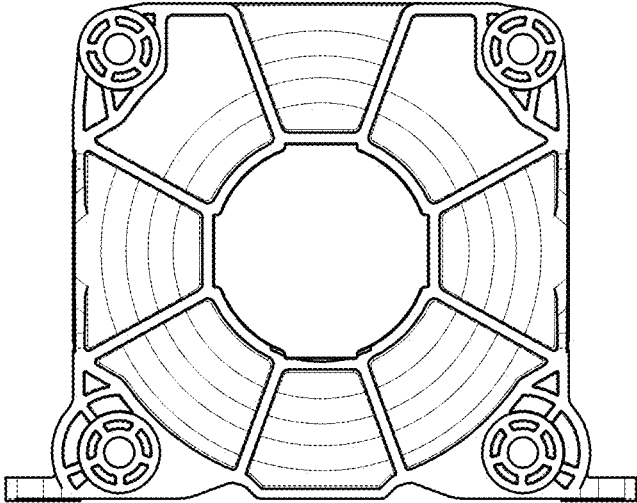

FIG. 36



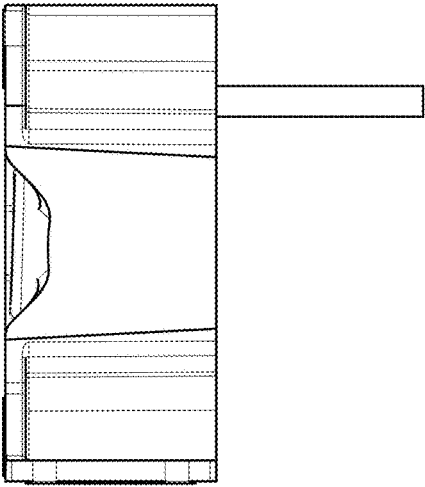

FIG. 37

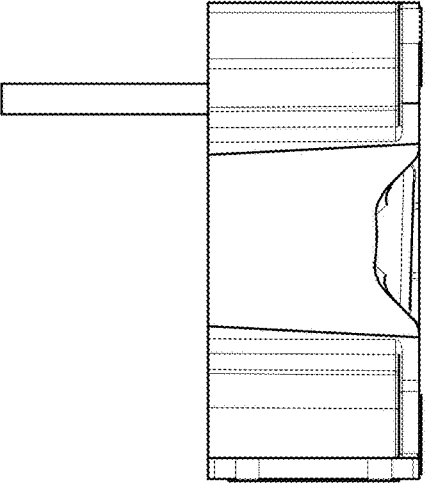

FIG. 38

FIG. 39

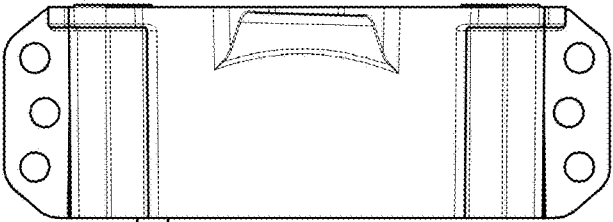

FIG. 40

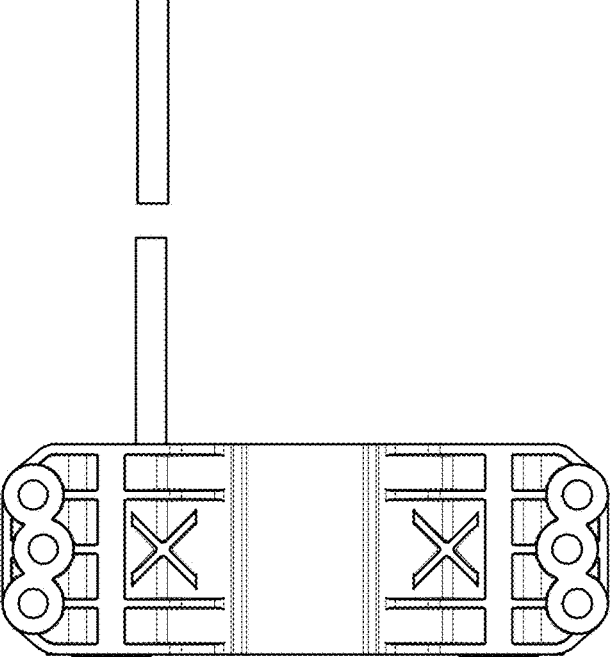

FIG. 41

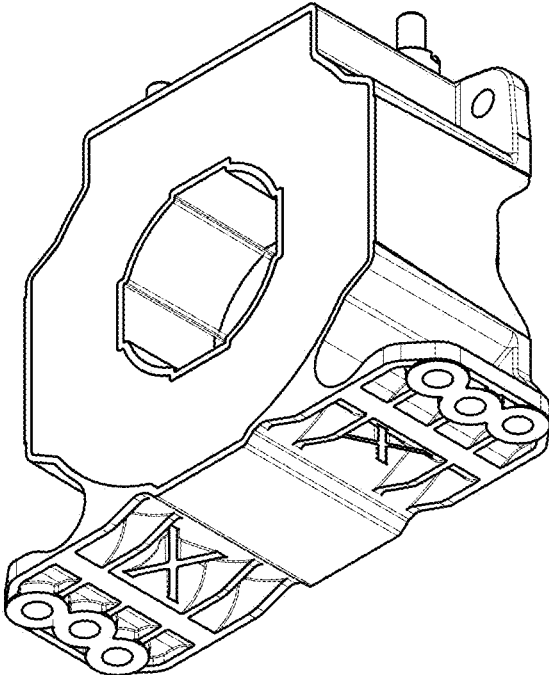

FIG. 42

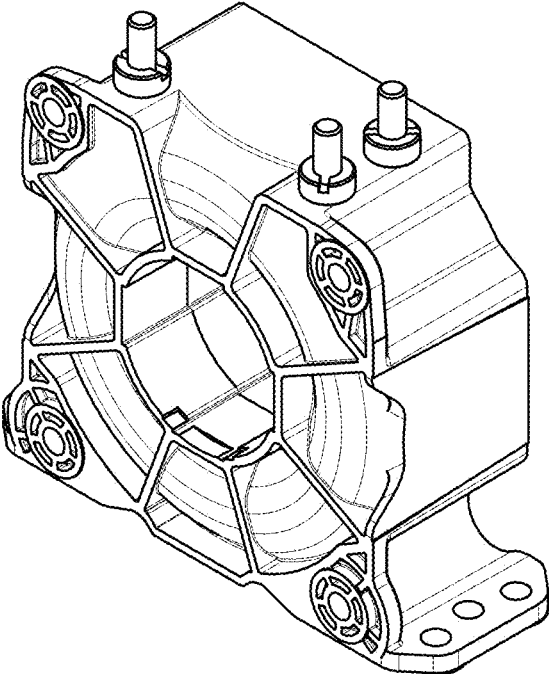

FIG. 43

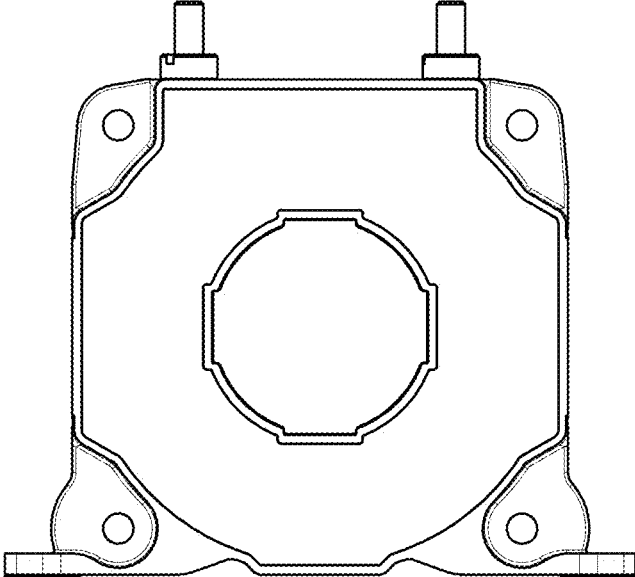
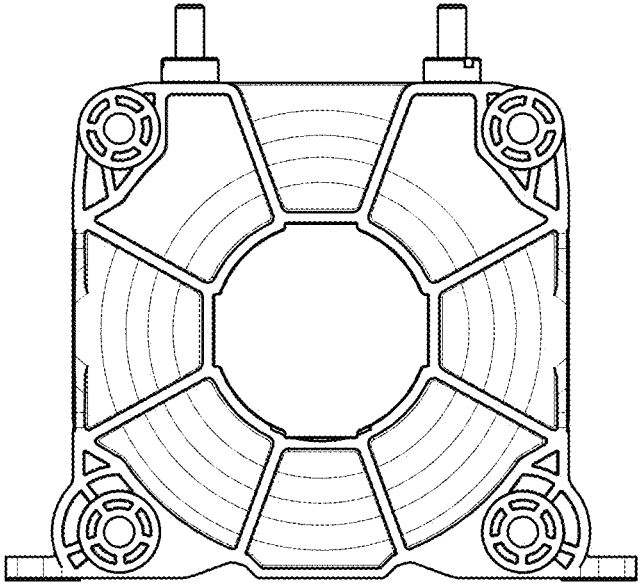

FIG. 44



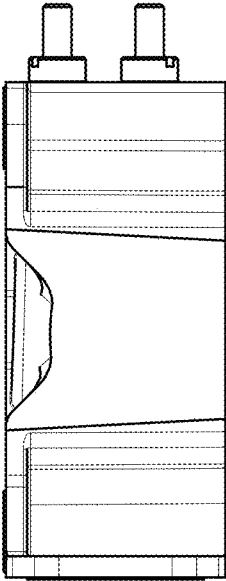

FIG. 45

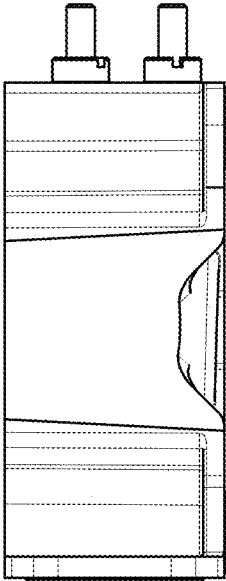

FIG. 46

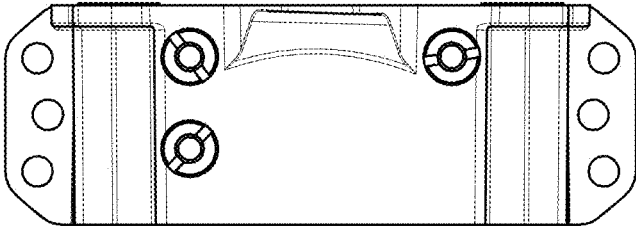

FIG. 47

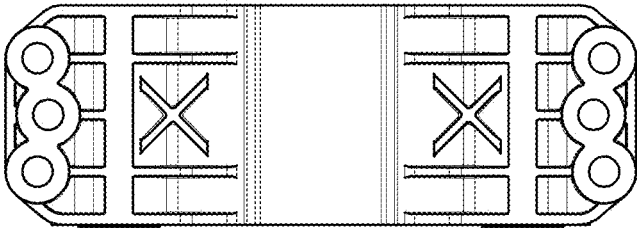

FIG. 48

FIG. 49

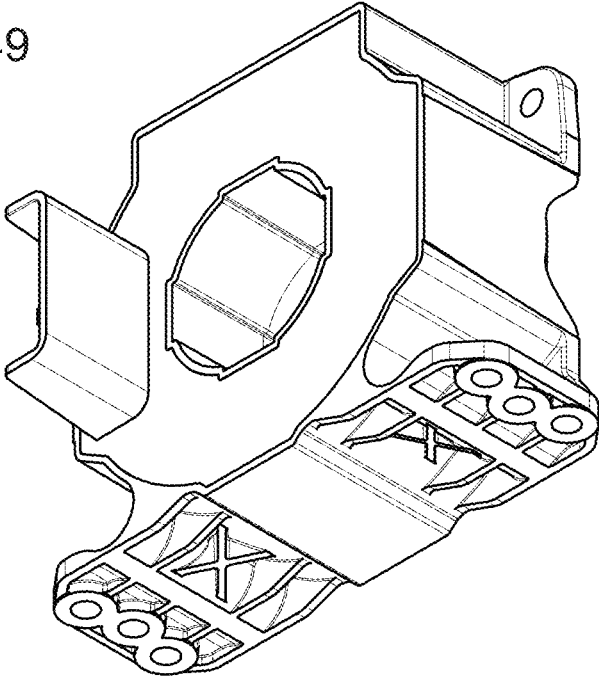

FIG. 50

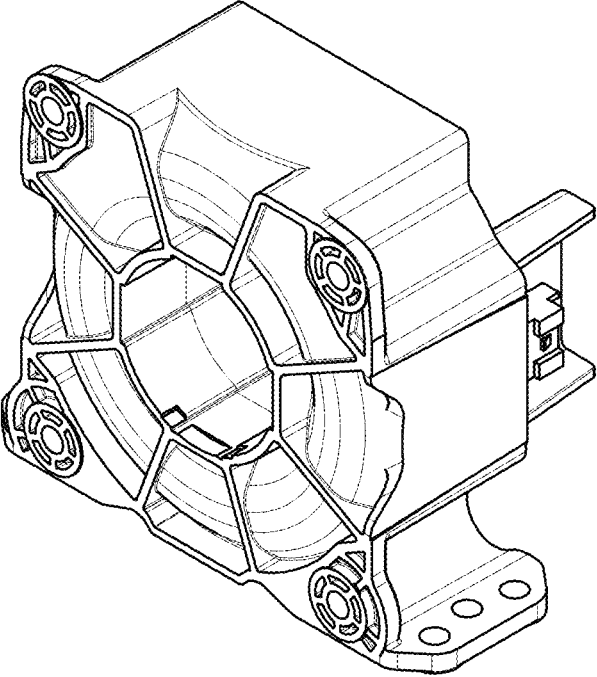

FIG. 51

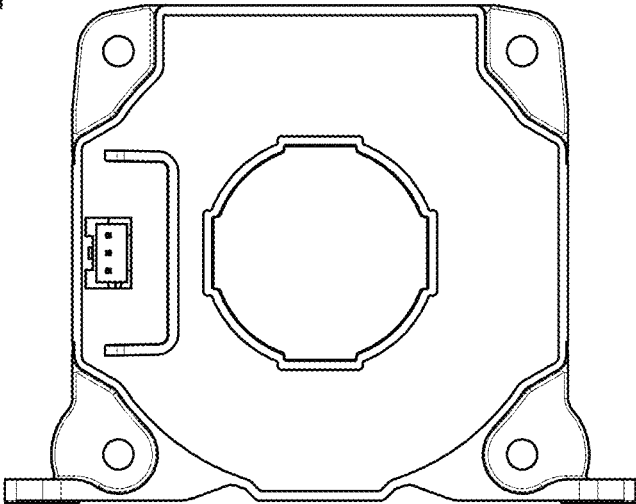
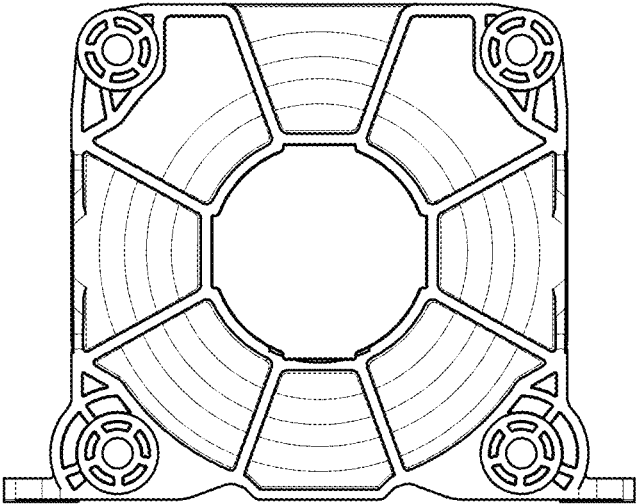

FIG. 52



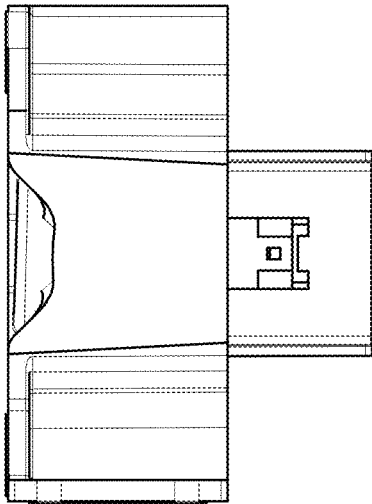

FIG. 53

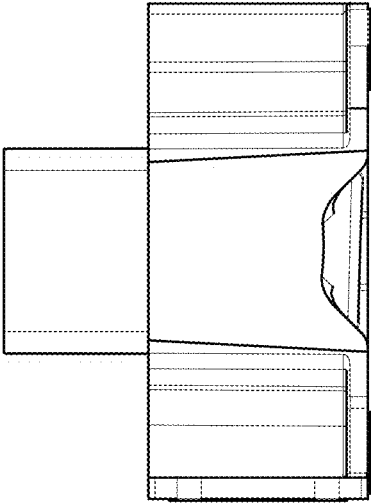

FIG. 54

FIG. 55

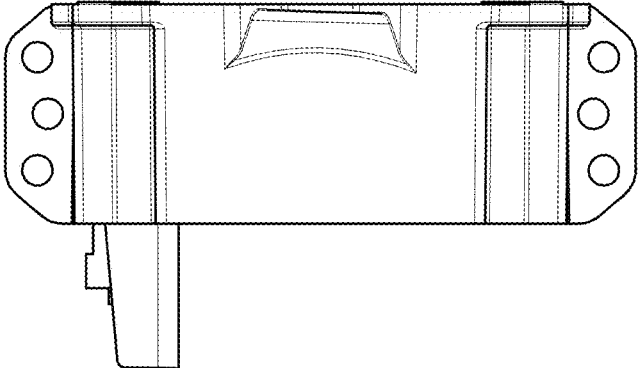

FIG. 56

