



(51) International Patent Classification:

B23K 26/08 (2006.01) *B32B 17/10* (2006.01)
B23K 26/00 (2006.01) *C03C 17/00* (2006.01)
B23K 26/40 (2006.01) *H01Q 15/00* (2006.01)
B23K 26/36 (2006.01) *H01Q 15/14* (2006.01)

(21) International Application Number:

PCT/GB2011/052231

(22) International Filing Date:

16 November 2011 (16.11.2011)

(25) Filing Language:

English

(26) Publication Language:

English

(30) Priority Data:

1019601.2 19 November 2010 (19.11.2010) GB

(71) Applicant (for all designated States except US): **PILK-
INGTON GROUP LIMITED** [GB/GB]; Prescott Road, St
Helens, Merseyside WA10 3TT (GB).

(72) Inventor; and

(75) Inventor/Applicant (for US only): **PAULUS, Peter**
[DE/DE]; Starweg 62, 48167 Muenster (DE).

(74) Agent: **MARSH, Andrew James**; Pilkington Group Lim-
ited, Intellectual Property, Pilkington European Technical
Centre, Hall Lane, Lathom, Ormskirk, Lancashire L40 5UF
(GB).

(81) Designated States (unless otherwise indicated, for every
kind of national protection available): AE, AG, AL, AM,
AO, AT, AU, AZ, BA, BB, BG, BH, BR, BW, BY, BZ,
CA, CH, CL, CN, CO, CR, CU, CZ, DE, DK, DM, DO,
DZ, EC, EE, EG, ES, FI, GB, GD, GE, GH, GM, GT, HN,
HR, HU, ID, IL, IN, IS, JP, KE, KG, KM, KN, KP, KR,
KZ, LA, LC, LK, LR, LS, LT, LU, LY, MA, MD, ME,
MG, MK, MN, MW, MX, MY, MZ, NA, NG, NI, NO, NZ,
OM, PE, PG, PH, PL, PT, QA, RO, RS, RU, RW, SC, SD,
SE, SG, SK, SL, SM, ST, SV, SY, TH, TJ, TM, TN, TR,
TT, TZ, UA, UG, US, UZ, VC, VN, ZA, ZM, ZW.

(84) Designated States (unless otherwise indicated, for every
kind of regional protection available): ARIPO (BW, GH,
GM, KE, LR, LS, MW, MZ, NA, RW, SD, SL, SZ, TZ,
UG, ZM, ZW), Eurasian (AM, AZ, BY, KG, KZ, MD, RU,
TJ, TM), European (AL, AT, BE, BG, CH, CY, CZ, DE,
DK, EE, ES, FI, FR, GB, GR, HR, HU, IE, IS, IT, LT, LU,
LV, MC, MK, MT, NL, NO, PL, PT, RO, RS, SE, SI, SK,
SM, TR), OAPI (BF, BJ, CF, CG, CI, CM, GA, GN, GQ,
GW, ML, MR, NE, SN, TD, TG).

Published:

— with international search report (Art. 21(3))

(54) Title: METHOD OF AND APPARATUS FOR MANUFACTURING A GLAZING WITH FREQUENCY SELECTIVE COATING

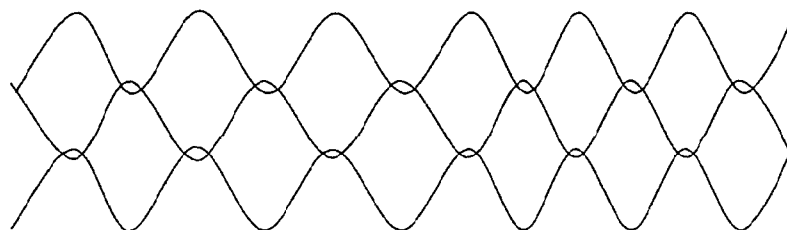

FIG. 2

(57) Abstract: The present application relates to a method of manufacturing a glazing having a frequency selective surface comprising the steps of: a) depositing a coating on a substrate, said coating being non-transmitting to radio frequency (RF) radiation; b) providing a laser beam and c) removing a portion of the coating by laser ablation to form one or more curves and/or lines having a spacing selected to provide transparency of the coating to RF radiation of a desired wavelength; wherein d) directing the laser beam and/or moving the substrate such that the relative motion of the intersection of the laser beam and the coating, with respect to the substrate, comprises motion in a first dimension, wherein said motion is simultaneously superimposed with a reciprocating motion in a second dimension; e) translating said intersection in the second dimension; and f) repeating at least step d) out of steps d) to f). An apparatus for such manufacturing is also described.



**METHOD OF AND APPARATUS FOR MANUFACTURING A GLAZING
WITH FREQUENCY SELECTIVE COATING**

The invention is concerned generally with provision of a surface on a coated substrate, which has frequency selective transmission characteristics and, in some embodiments, to
5 providing such a surface on glazing sheets having a solar control coating deposited thereon.

In glazing for buildings and automotive applications, antennas for reception and, or transmission of radio frequency (RF) waves are commonly incorporated. These may be
10 realised as, for example, conductive films deposited on the glazing or metal wires or strips attached thereto. In laminated glazings, which typically comprise two or more glass sheets bonded by a polymer interlayer, the antennas might be located within the laminate i.e. within the interlayer or on a glass surface contacting the interlayer.

15 In addition, in many cases additional equipment is operated within the vehicle or the building, which radiates and/or receives radiofrequency signals. To ensure function of this equipment, sufficient transmittance through the glazing is necessary.

Although glazing sheets, particularly for automotive applications, are predominantly
20 formed in glass, other materials such as polycarbonates are known and references to glass throughout this application should not be regarded as limiting.

In order to reduce the accumulation of heat in the interior of a building or vehicle, a glazing sheet may be coated with a solar control film that absorbs or reflects solar energy.
25 Inclusion of solar control films, particularly on glazings for use in warm, sunny climates, is desirable because they reduce the need for air conditioning or other temperature regulation methods. This affords savings in terms of energy consumption and environmental impact.

30 Such films, however, are typically electrically conductive and can also reflect RF waves. This effect impedes reception or transmission by antennas.

A simple approach to this problem of RF energy reflection is to remove the solar control film in the region of the glazing near the antenna. This approach, however, reduces the solar control benefits offered by the glazing and for equipment located inside the vehicle or the car, the region would be unacceptably large.

5

Another solution has been to cut slits in the solar control film to create a surface which is frequency selective, that is, it has relatively high reflectivity/absorbance for solar energy but relatively low in the RF region of the electromagnetic spectrum. The cutting may be performed by laser ablation and the spacing of the slits is chosen to provide selectivity at
10 the desired frequency.

By one approach a series of horizontal and vertical lines are cut in the film to produce a grid pattern. By appropriate choice of the line spacing, a grid can be produced that is transparent to RF waves but substantially reflecting or absorbing to solar energy.

15

The lines are typically cut by laser marking using a 'galvo-head', that is a system in which the direction of a cutting laser beam is controlled by deflecting a rotatable mirror or mirrors using a galvanometer based motor. This arrangement allows the direction of the laser to be controlled and changed rapidly but is limited in terms of the working field (i.e.
20 the area over which a grid can be cut).

The greater the distance, f , between the laser and the substrate, the greater the size of the working field. However, increasing f increases the diameter D of the focussed laser which in turn increases the line width in the grid. Lines of increased width require higher laser
25 energy and are more noticeable to the eye.

Using the prior art approach, grids of up to about 300mm in height and width are practical. This is adequate for small antennas for devices such as toll monitoring systems but there is an increasing demand, in the automotive industry in particular, for antennas
30 extending across the majority of the glazing.

One approach to meeting this demand has been to combine a number of grids, each corresponding with the working field of the laser. Thus a grid is cut and then the glazing sheet repositioned relative to the laser so that the next grid is cut alongside the previous one. The process is repeated until the required area of the glazing is covered by a large grid comprised of a number of merged smaller grids.

A number of problems are associated with this approach however. First, the repeated repositioning of the glazing sheet is time consuming and introduces a delay to the production process.

Second, while the grid patterns must be positioned very accurately, it is necessary to avoid any conductive regions between them. This is achieved by arranging for a slight overlap between adjacent grids but that in turn gives rise to an undesirable visual effect: the boundaries between adjacent grids are emphasised by the misalignment and this is displeasing aesthetically and visually distracting.

Another (general) approach to achieving laser cut patterns over a relatively large area is to mount the laser on an X-Y plotter, many examples of which are known in the art. Such an arrangement provides a means of directing the laser over a larger working area but its use is limited by its speed of operation. In order to cover a major portion of (for example) an automobile backlight with laser cuts having the requisite spacing, a significant number of stops, starts and turns is necessary.

It is also noted that the straight horizontal and vertical lines in a grid arrangement are more noticeable to the human eye and produce a pattern that is less aesthetically pleasing and more visually distracting than one based on curves or loops.

There remains a requirement for a means of rapidly producing a laser cut pattern over the majority of a glazing sheet such as employed in a building or automobile glazing unit. According to the invention, this requirement is met by the method according to claim 1 and the apparatus according to claim 5 appended hereto.

The invention is based on the resolution of the laser motion into two components, conveniently two orthogonal components designated as X and Y. Thus, one component can be realised as sweeps of the laser across the width of the glazing sheet (in the X dimension), while the other component can be realised as motion in the Y dimension over a relatively short distance. Combination of these two components produces a two-dimensional undulating pattern.

The invention will now be described, by non-limiting example, with reference to the following figures in which:

10 Figures 1a and 1b illustrate some of the problems associated with prior art approaches to providing a frequency selective coating across a large area of a glazing;

figures 2 and 3 illustrate examples of cutting patterns applied to frequency selective coatings according to the invention;

15

figure 4 shows an embodiment of the invention;

figures 5 and 6 show examples of means for achieving a component of the laser beam motion according to the invention.

20

Referring to figure 1a, in order to ensure satisfactory transmittance across the whole of a region of a coated glazing, covered by a plurality of grid patterns 14, it is necessary to avoid any uncut, conductive regions 15 between adjacent grids. This is achieved by arranging for a slight overlap between adjacent grids (figure 1b) but the region of overlap 16 is visually striking and gives rise to an appearance that is aesthetically displeasing and distracting to a viewer.

25

Figure 2 illustrates a typical pattern of cutting in a glazing coating according to the invention. The X component of the laser motion comprises a series of relatively long sweeps in the X dimension across the width of the glazing sheet. A reciprocating motion in the Y dimension is superimposed on this motion in the X dimension to provide an undulating, wave-like pattern. By this approach, the coating over the whole of the glazing

30

can be cut with a pattern having both horizontal (X) and vertical (Y) components, with few stops in the laser journey.

Note that in order to provide more effective RF transparency, the undulating lines touch or overlap.

Figure 3 illustrates an alternative pattern of cutting according to the invention. Again, the cut pattern includes both X and Y components.

Referring to figure 4, a simple embodiment of the invention comprises a conventional X-Y plotter, adapted to direct a laser beam 11, and suitably programmed to provide a cut pattern according to the invention.

The apparatus, generally designated 1, thus comprises a gantry 2 moveable in the X dimension by a combination of stepper motor, pulleys and drive belts (not shown) which may be suitably arranged by a person skilled in the art without further instruction here.

A mirror 3 is mounted on gantry 2 and is moveable in the Y dimension by another stepper motor/pulley/drive belt arrangement, also not shown. Thus, the position of mirror 3 over a substantial part of glazing 4 may be controlled. In practice the mirror would typically be fixed to a carriage (not shown), the latter being mounted on the gantry and moveable thereon.

A laser source 5 provides a laser beam 11 which is directed via a set of mirrors 6, 7, 8 and 3 on to glazing 4. Mirrors 6 and 7 are fixed in a plane perpendicular to the plane of glazing 4; mirror 8 moves with gantry 2 but remains perpendicular to the plane of glazing 2 and arranged to direct the laser beam 11 on to mirror 3. Mirror 3 lies in a plane which intersects the plane of glazing 4 and is arranged to direct the laser beam 11 thereto.

Hence the laser beam 11 may be directed to any point over a substantial part of glazing 4 by appropriate movement of gantry 2 in the X dimension and mirror 3 in the Y dimension.

The arrangement of mirrors shown in figure 4 is one example only: other arrangements for directing the laser beam to the glazing are possible.

Machine readable instructions (a program) to determine the movement of mirror 3 are stored and executed by a computer 9 and a controller 10 converts signals produced by computer 9 to electrical signals suitable for driving the stepper motors.

Computer 9 is typically a microprocessor based system which may be realised as a desktop or laptop or may be integrated with the rest of the apparatus.

10

Computer 9 is loaded with a program which causes gantry 2 to move in a series of sweeps in the X dimension across glazing 4. During each sweep, the program causes the mirror to execute a reciprocating motion in the Y dimension, centred on a point P_y which is one of a series of points $P_0 - P_n$ distributed along gantry 2. Between each sweep of the gantry, y is incremented i.e. the mirror moves in the Y direction to be ready to reciprocate about the next point in the series.

The system could be arranged such that the laser performs the cutting action during movement in one sense (e.g. left to right) with the mirror advancing to the next point P_y while the gantry resets to the left side of the glazing in preparation for the next sweep. Alternatively, the laser could perform the cutting action during movement in both senses (left to right and right to left) with the mirror advancing while the gantry stops at each end of the working field.

The sinusoidal pattern suggested in figure 4 is achievable by programming the apparatus to move the gantry 2 at a constant speed in the X dimension and superimposing a simple harmonic motion on the mirror 3 in the Y dimension. Appropriate choice of the relative phase of motion between sweeps allows the 'peaks' of a given sweep to be aligned with the 'troughs' of adjacent sweeps. It will be apparent to those skilled in the art that other patterns are achievable.

30

The embodiment of the invention illustrated in figure 4 offers advantages over the prior art by eliminating the need for sweeps in the Y dimension. Aesthetically displeasing and visually distracting straight lines are also avoided.

5 Nevertheless, the embodiment illustrated in figure 4 is limited by the capabilities of a conventional X – Y plotter. In particular, the reciprocating motion in the Y direction still requires relatively fast and frequent stops and changes of direction and this requirement may not be met by the stepper motor based systems of the prior art.

10 In a preferred embodiment, further means for realising the vertical component of the cut pattern is introduced. The further means is operable independently of the stepper motors of the X-Y plotter and is capable of more rapid motion, stops and changes of direction.

Referring to figures 5a and 5b, the further means for introducing the vertical component of the pattern may comprise an actuator 12 (e.g. electro-mechanical or pneumatic) mounted on the gantry 2. The actuator is operable to move mirror 3 in the Y dimension, between two positions, relative to the gantry 3 while the gantry sweeps across the glazing 4 in the X dimension. It should be noted, that the Y stepper motors of the X-Y plotter still ensures the change of average y-position P_y from one horizontal sweep to the next

20

Referring to figures 6a and 6b, as an alternative to moving mirror 3, the mirror may be rotated between two orientations such that the angle of the laser beam reflecting from the mirror 3 oscillates and the intersection 13 between the laser beam and the glazing 4 varies in the Y direction while the gantry 2 sweeps in the X direction (X direction being perpendicular to the plane of the page).

25

As an alternative to actuator 12, mirror 3 may be moved or rotated using a galvo-head.

It should be noted that while the invention has been described and illustrated with reference to 'X' and 'Y' dimensions, these designations are arbitrary. The invention may be worked by performing a series of sweeps of the laser across the glazing in any (first) dimension and superimposing on this motion a second, cyclic, motion of the laser or laser

30

beam where the second motion has a component in a second dimension, different from the first dimension. Of course, the first and second dimensions most conveniently lie in the plane of the glazing.

- 5 It also should be noted that sweeps themselves do not need to be straight lines, according to design (aesthetic) requirements these sweeps can be curved lines, realised by the X-Y capabilities of the plotter.

The term 'X-Y' plotter has been exemplified by 'gantry and carriage' based systems but
10 this should not be seen as limiting and the invention may be realised by other means of controlling the position of an object in two dimensions, for example, a robotic arm.

It also is possible to achieve the relative motion between the laser beam and the coated glazing, wholly or in part, by moving the glazing. This may be achieved by mechanical
15 engineering design solutions that are within the knowledge of a skilled person and require no further description here.

Moreover, in the examples shown, the laser beam is directed by a series of mirrors which may be combined with other optical elements such as lenses. Nevertheless, other means
20 for directing the laser, such as a fibre optic cable, may be employed.

It is possible to use more than one mirror 3 (together with actuator 12) or more than one fibre outlet of a Laser, in order to scribe more than one line in parallel to the glass.

Claims

1. A method of manufacturing a glazing having a frequency selective surface comprising the steps of:
- 5
- a) depositing a coating on a substrate, said coating being non-transmitting to radio frequency (RF) radiation;
- b) providing a laser beam and
- 10
- c) removing a portion of the coating by laser ablation to form one or more curves and/or lines having a spacing selected to provide transparency of the coating to RF radiation of a desired wavelength;
- 15
- characterized by
- d) directing the laser beam and/or moving the substrate such that the relative motion of the intersection of the laser beam and the coating, with respect to the substrate, comprises motion in a first dimension, wherein said motion is simultaneously superimposed with a reciprocating motion in a second dimension;
- 20
- e) translating said intersection in the second dimension; and
- f) repeating at least step d) out of steps d) to f).
- 25
2. A method according to claim 1, where the reciprocating motion comprises a simple harmonic motion.
3. A method according to claim 1, where the reciprocating motion occurs at a constant speed.
- 30
4. A method according to any preceding claim, where the first dimension and the second dimension are substantially perpendicular to each other.

5. Apparatus for providing a frequency selective surface on a substrate having a coating that is non-transmitting to RF radiation, said apparatus comprising:

5 a laser source, able to provide a laser beam suitable for ablation of the coating;

means for directing the laser beam and/or means for moving the substrate such that the relative motion of the intersection of the laser beam and the coating, with respect to the substrate, comprises:

10

motion in a first dimension, wherein said motion is simultaneously superimposed with a reciprocating motion in a second dimension; and

a translation of said intersection in the second dimension.

15

6. Apparatus according to claim 5, comprising an X-Y plotter arranged to direct the laser beam responsive to signals received from a computer, said computer being programmed to generate signals causing the X-Y plotter to direct the laser beam as set out in claim 5.

20 7. Apparatus according to claim 5, comprising:

first means for directing the laser beam such that the intersection exhibits the reciprocating motion in the second dimension and

25 second means for transporting the first means in a series of sweeps in the first dimension and in a series of translations in the second dimension.

8. Apparatus according to claim 7, where the second means comprises a gantry operable to move in the first dimension and a carriage, mounted on the gantry and operable to
30 move on the gantry in the second dimension.

9. Apparatus according to claim 8, where the second means comprises a mirror and an actuator mounted on the carriage, the actuator being operable to cause reciprocating motion of the mirror in the second dimension.
- 5 10. Apparatus according to claim 8, where the second means comprises a mirror and an actuator mounted on the carriage, the actuator being operable to cause reciprocating rotation of the mirror between two orientations.

1/6

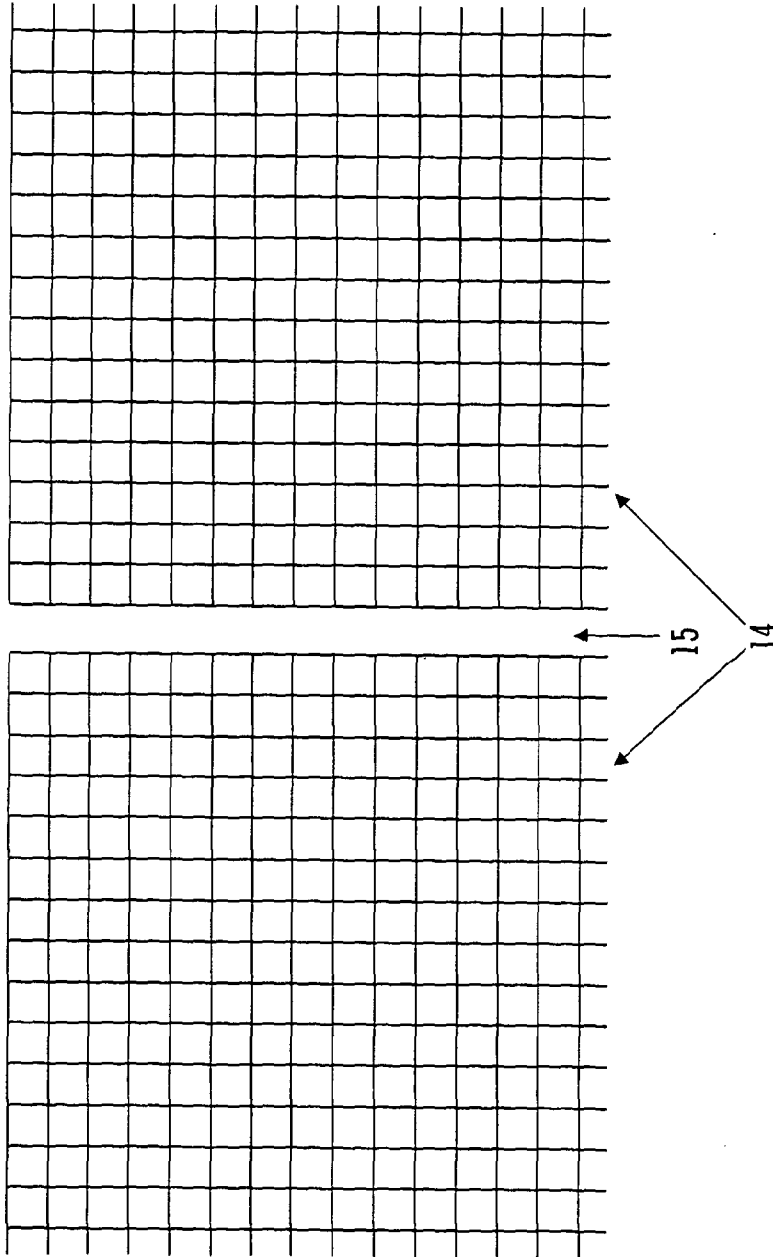

FIG. 1a

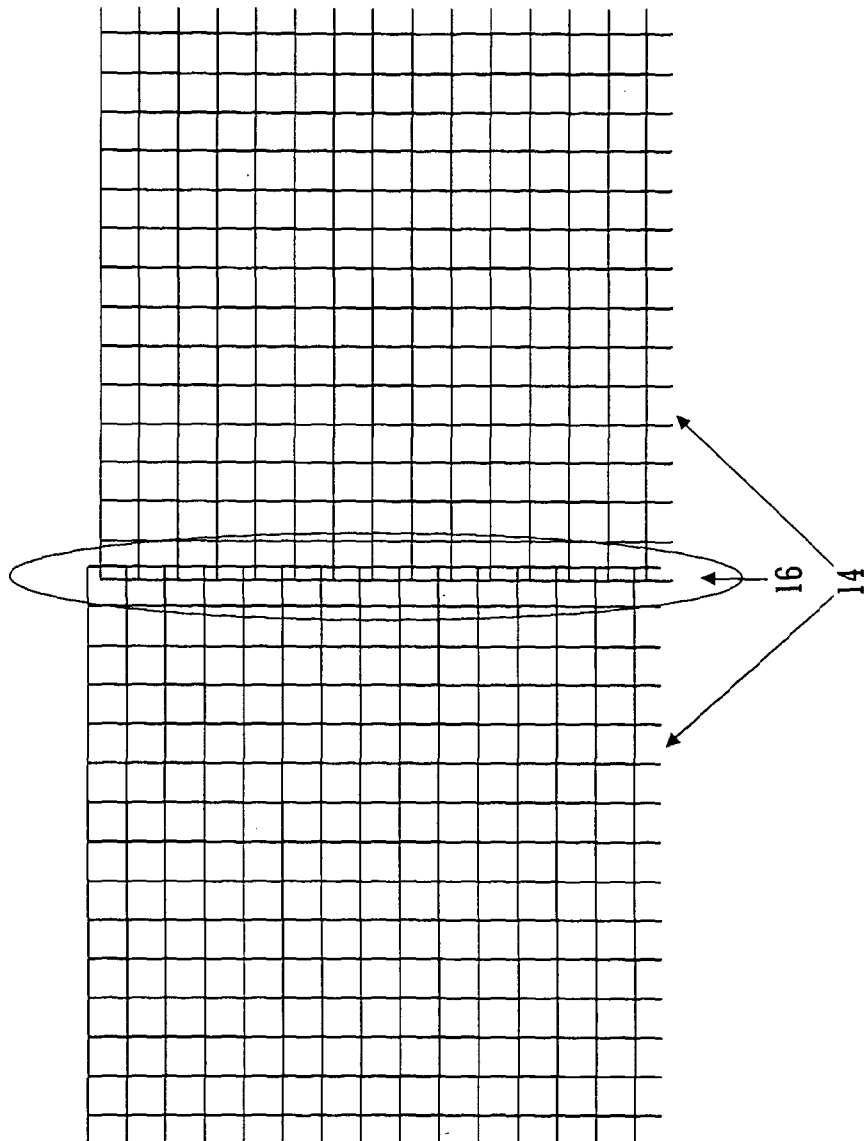

FIG. 1b

3/6

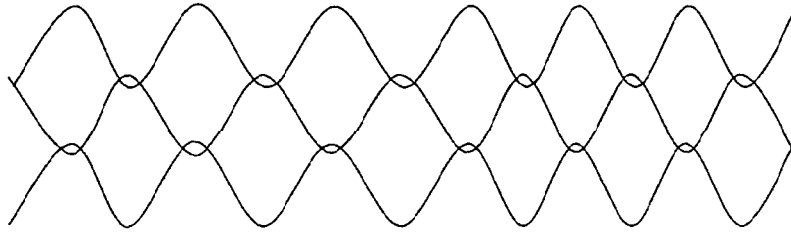

FIG. 2

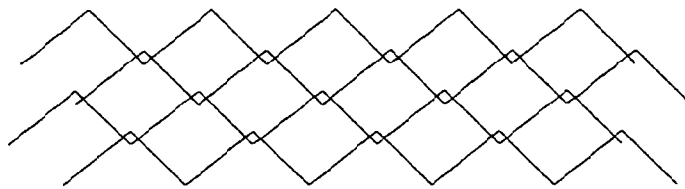

FIG. 3

4/6

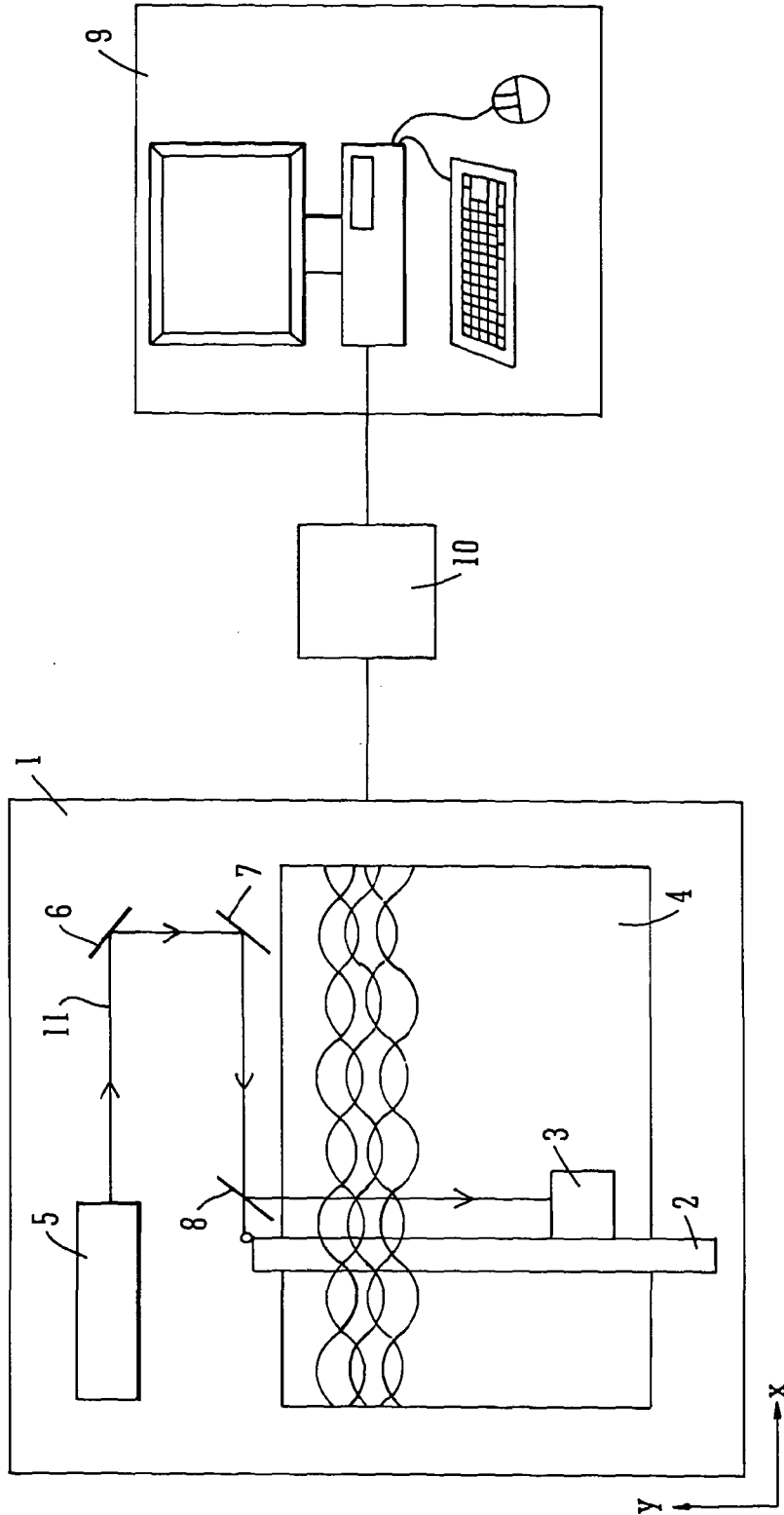

FIG. 4

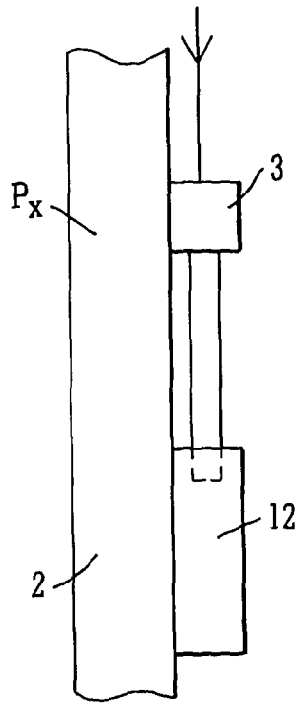

FIG. 5a

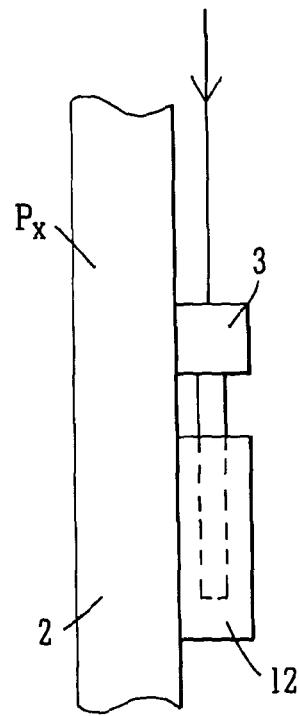

FIG. 5b

6/6

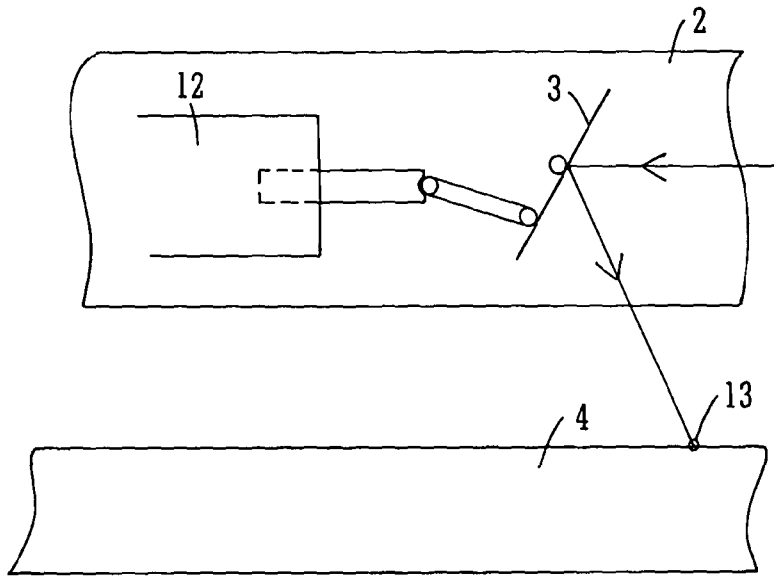

FIG. 6a

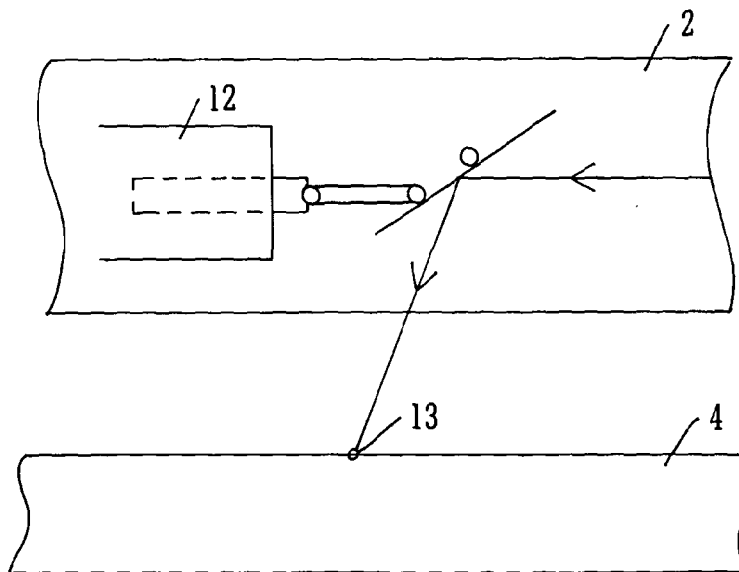

FIG. 6b

INTERNATIONAL SEARCH REPORT

International application No
PCT/GB2011/052231

A. CLASSIFICATION OF SUBJECT MATTER
 INV. B23K26/08 B23K26/00 B23K26/40 B23K26/36 B32B17/10
 C03C17/00 H01Q15/00 H01Q15/14
 ADD.
 According to International Patent Classification (IPC) or to both national classification and IPC

B. FIELDS SEARCHED
 Minimum documentation searched (classification system followed by classification symbols)
 B23K B32B C03C H01Q

Documentation searched other than minimum documentation to the extent that such documents are included in the fields searched

Electronic data base consulted during the international search (name of data base and, where practical, search terms used)
 EPO-Internal, WPI Data

C. DOCUMENTS CONSIDERED TO BE RELEVANT

Category*	Citation of document, with indication, where appropriate, of the relevant passages	Relevant to claim No.
X	US 6 066 830 A (D. CLINE ET AL) 23 May 2000 (2000-05-23)	5-10
Y	column 11, line 13 - column 9, line 55 -----	1-4
Y	US 2006/152421 A1 (D. BARANSKI) 13 July 2006 (2006-07-13) paragraphs [0024], [0033]; claims 1,14; figures -----	1-4
X	JP 2007 307723 A (MIYACHI TECHNOS CORP) 29 November 2007 (2007-11-29)	5-10
A	abstract; figures -----	1-4
X	US 2006/175301 A1 (P. RIPPL) 10 August 2006 (2006-08-10)	5,7
A	paragraph [0041]; figures -----	1-4
	-/--	

Further documents are listed in the continuation of Box C. See patent family annex.

* Special categories of cited documents :

<p>"A" document defining the general state of the art which is not considered to be of particular relevance</p> <p>"E" earlier document but published on or after the international filing date</p> <p>"L" document which may throw doubts on priority claim(s) or which is cited to establish the publication date of another citation or other special reason (as specified)</p> <p>"O" document referring to an oral disclosure, use, exhibition or other means</p> <p>"P" document published prior to the international filing date but later than the priority date claimed</p>	<p>"T" later document published after the international filing date or priority date and not in conflict with the application but cited to understand the principle or theory underlying the invention</p> <p>"X" document of particular relevance; the claimed invention cannot be considered novel or cannot be considered to involve an inventive step when the document is taken alone</p> <p>"Y" document of particular relevance; the claimed invention cannot be considered to involve an inventive step when the document is combined with one or more other such documents, such combination being obvious to a person skilled in the art.</p> <p>"&" document member of the same patent family</p>
--	--

Date of the actual completion of the international search 17 February 2012	Date of mailing of the international search report 01/03/2012
---	--

Name and mailing address of the ISA/ European Patent Office, P.B. 5818 Patentlaan 2 NL - 2280 HV Rijswijk Tel. (+31-70) 340-2040, Fax: (+31-70) 340-3016	Authorized officer Jeggy, Thierry
--	--

INTERNATIONAL SEARCH REPORT

International application No
PCT/GB2011/052231

C(Continuation). DOCUMENTS CONSIDERED TO BE RELEVANT		
Category*	Citation of document, with indication, where appropriate, of the relevant passages	Relevant to claim No.
A	US 2004/113860 A1 (E. K. WALTON) 17 June 2004 (2004-06-17) abstract; claims; figures -----	1,5

INTERNATIONAL SEARCH REPORT

Information on patent family members

International application No

PCT/GB2011/052231

Patent document cited in search report	Publication date	Patent family member(s)	Publication date
US 6066830	A	23-05-2000	AU 4547299 A
			US 6066830 A
			WO 9962668 A1

US 2006152421	A1	13-07-2006	NONE

JP 2007307723	A	29-11-2007	NONE

US 2006175301	A1	10-08-2006	AT 345188 T
			DE 10333456 A1
			EP 1648650 A1
			ES 2277266 T3
			US 2006175301 A1
			WO 2005009667 A1

US 2004113860	A1	17-06-2004	AU 2003298734 A1
			US 2004113860 A1
			WO 2004051869 A2
