

- [54] SEAMLESS BRASSIERES AND BRASSIERE BLANKS
- [76] Inventor: Giuseppe Novi, Via della Repubblica 15, Pontedera, Italy
- [22] Filed: Feb. 23, 1971
- [21] Appl. No.: 118,016
- [30] Foreign Application Priority Data
 - Mar. 4, 1970 Italy45208A/70
 - Sept. 7, 1970 Italy45216A/70
- [52] U.S. Cl. 66/176, 128/517, 128/465, 128/463
- [51] Int. Cl. A41b 9/06
- [58] Field of Search 66/173, 176, 170, 66/171, 54; 128/464, 465, 517, 463

FOREIGN PATENTS OR APPLICATIONS
 16,273 11/1898 Great Britain 66/176

Primary Examiner—Ronald Feldbaum
 Attorney—Stewart J. Fried and Jeffrey A. Schwab

[57] ABSTRACT

There is described an article adapted for ready deformation into a brassiere defining blank generally including a longitudinally knit seamless tubular artefact having successively knit portions of varying diameters in adjacent portions. The tubular artefact is preferably knit longitudinally on a circular knit hosiery machine. Deformation may be effected by use of a wire form which is inserted longitudinally within the tubular knit article thus flattening the article into two superimposed layers with a portion of the periphery of the wire defining the upper and lower edges desired for the cups of the blank. Three dimensional forms inserted within the periphery shapes the bust areas to three dimensions.

- [56] References Cited
- UNITED STATES PATENTS

3,531,952	10/1970	Chesebro	66/171
3,169,385	2/1965	Haberhauer	66/54
3,256,716	6/1966	Hanel	66/54
2,966,785	1/1961	Goff et al.	66/176
1,868,854	9/1932	Smarr	66/175
3,537,279	11/1970	Epley	66/176
1,984,326	12/1934	Titone	66/176
1,863,697	6/1932	Rutledge	66/176

9 Claims, 14 Drawing Figures

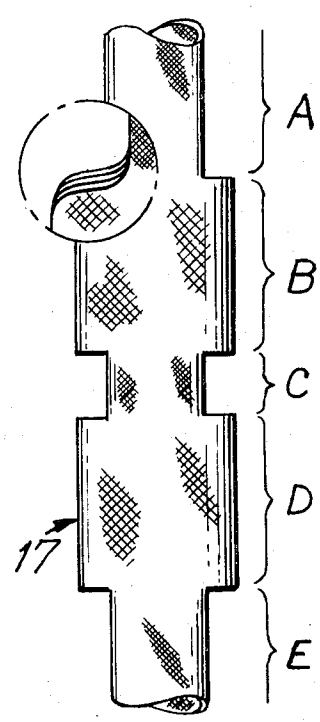

FIG. 1

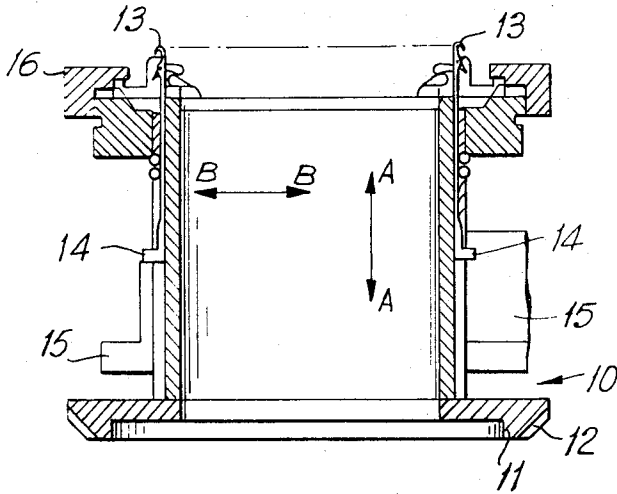

FIG. 2

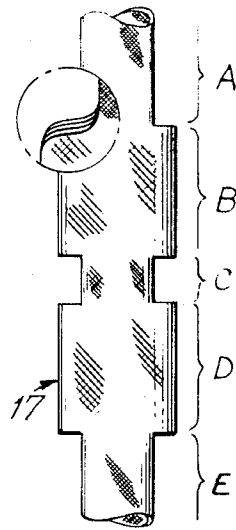

FIG. 2a

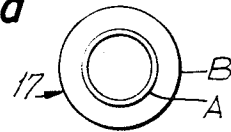

FIG. 3

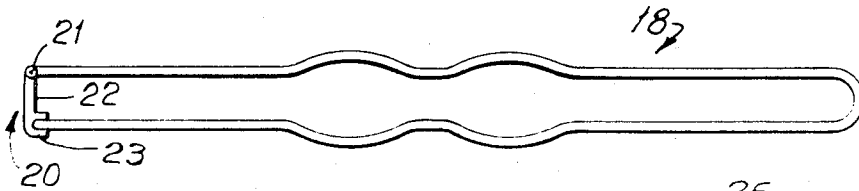

FIG. 5

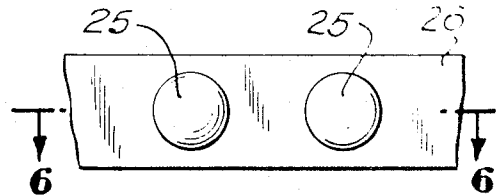

FIG. 4

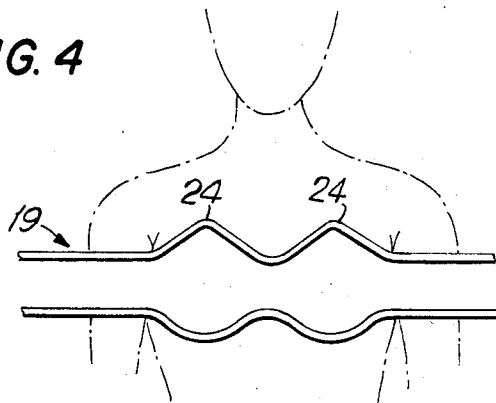
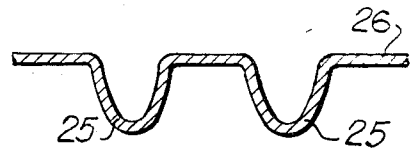

FIG. 6



INVENTOR.
GIUSEPPE NOVI

BY
Stewart J. Fried
Jeffrey B. Schwab
ATTORNEYS

FIG. 7

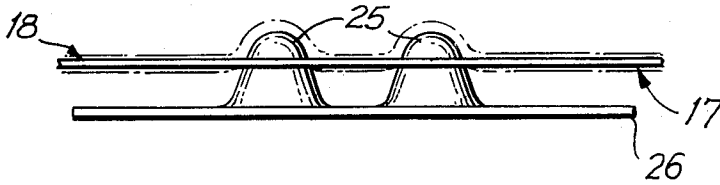

FIG. 8

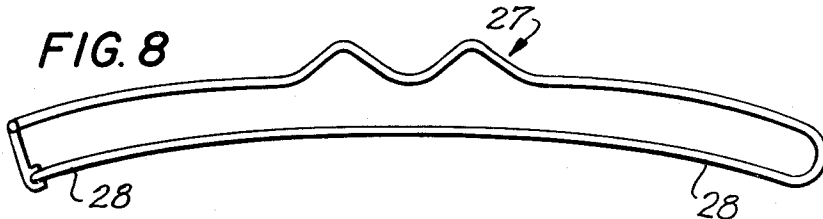

FIG. 9



FIG. 13

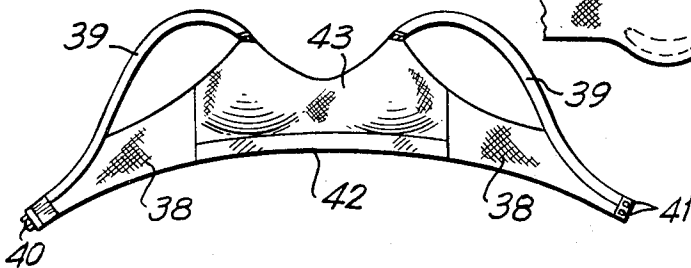

FIG. 10

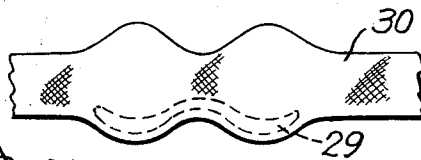
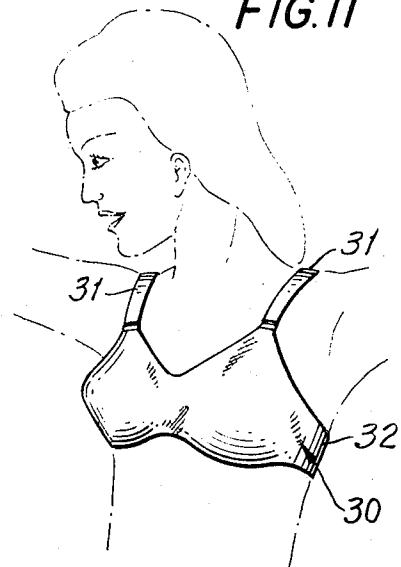

FIG. 11



INVENTOR.
GIUSEPPE NOVI

BY
Stewart J. Fried
Jeffrey A. Schwab
ATTORNEYS

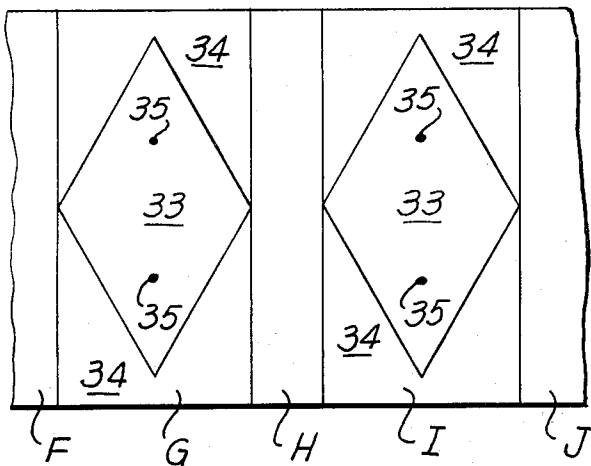

FIG. 12

SEAMLESS BRASSIERES AND BRASSIERE BLANKS

CROSS REFERENCES

The present application is based upon Italian Pat. application No. 45208A/70 entitled KNITTED BRA PRODUCED BY MOLDING and dated Mar. 4, 1970 and Italian Pat. application No. 45,216A/70 entitled "Improvement in Knitted Bra Produced By Molding" dated Sept. 7, 1970 and applicant claims priority under 35 U.S.C. 119 based upon the above application.

The present invention relates to seamless brassiere blanks and to methods and apparatus for constructing the same.

With the greater emphasis on what has been termed a more "natural" look in women's fashions, various attempts have been made to provide a brassiere having a smooth silhouette. In some instances products have been developed whereby existing brassiere constructions have been modified by substituting a softer material, such as tricot for the previously employed more firm or rigid fabric constituents in the cups of the brassiere. While this type of modification does serve to "soften" the look of the garment to some extent both on and off the body, it does not fully solve the problem since each cup is still constructed in the manner heretofore employed for more rigid fabrics. That is, two or three fabric sections are sewn together. The seaming lines usually include a somewhat horizontal medial seam line extending through the sewn cup. The sewn together constituents provides a semispherical cup component which is in turn sewed into the basic body encircling brassiere frame. Even with the material substitution hereinbefore described, a prominent seam is still included along each cup. Aside from detracting from the overall aesthetics of the garment, oftentimes the outline of the seam line is either visible through outer tight fitting garments and/or provides discomfort to the wearer by direct contact of the seam edge with the breast.

In an attempt to provide a seamless cup, work has progressed in the field of molded cups whereby a heat setting sheet of material is formed by means of dies into a breast cup shape, with the resultant molded cups sewed into a brassiere frame. While this procedure eliminated the medial seam line in the cups, it still does not fully solve the entire problem. Seaming is still required about the outer periphery of the cup thus again presenting the problem of undesired aesthetic appeal and possible discomfort due to contact with the wearer's flesh. Additionally, this type of molding operation not only sets the cup material into a given configuration, it further rigidizes certain undesired regions of the cup, and does not retain its molded shape after extensive periods of wear.

In lieu of molded cups, some attempts have been made to employ stretch material in the cups with the cups shaped by darts. While this overcomes certain problems of molded cups, the darts present problems equivalent to those encountered in seamed garments and of greater significance, a garment constructed by use of stretchable cup material seriously detracts from the supportive function of the brassiere.

To overcome the foregoing problems, many recent attempts have been made in the field of knitting a brassiere blank as an integral unit. In more recent years flat bed full fashioning equipment has been adapted for

brassiere blank knitting with the cups of the brassiere being fashioned by progressive widening and narrowing along either side of a medial row of plain knit wales extending horizontally through the cups.

While full fashion knitting of brassiere blanks has gone a long way in solving the problem of providing a seamless brassiere blank, it is still not the complete answer. While there is no seam in the cups, the medial fashioning lines do present an area of visual discontinuity with respect to the upper and lower portions of the cups, thus resulting in the visual equivalent of a seam even though no seam in fact is present. Aesthetic problems aside, flat bed full fashioning equipment is by its nature a slower method of knitting when compared with circular knit hosiery equipment.

While some attempts have been made to employ circular knitting equipment for breast receiving articles, such as brassieres, it would appear that such attempts have been primarily directed to knitting the blank in a manner akin to the flat bed knitting techniques. For example, attempts have been made to knit pockets or cups of the blank by widening and narrowing along selected areas employing various camming arrangements to provide for a reciprocating program of the needle cylinder akin to the knitting program generally employed in knitting the heel portion in hosiery. There are thus required rather complex programs whereby a substantial number of the needles remain inactive during portions of the knitting. Further, the blanks are knit circumferentially from bottom to top, as distinguished from lengthwise, thus placing a limitation on the size of the blank which can be knit on a given diameter cylinder.

According to the present invention, the aforescribed problems are overcome.

The invention provides for the use of circular knit hosiery equipment to produce a longitudinally knit tubular article adaptable for selective deformation into a two-ply brassiere blank. Through the implementation in at least a portion of the tubular knit article of deformable and heat stabilizing yarns, a seamless, subtle yet supportive brassiere blank can be constructed by subjecting the longitudinally knit article to deformation elements, such as molding dies to stabilize the yarns to a finished blank shape.

In its simplest form, the knitted article provides for the continuous knitting of a series two sizes of stitches. Smaller size stitches are knit to form that portion of the tubular article which in the finished blank will correspond to the circumferential band sections or dorsal portions of the blank. A series of larger stitches are knit and correspond to the two cups of the blank. Intermediate the series of larger stitches is a series of smaller stitches which may be equal in size to those stitches which will correspond to the dorsal portion stitches of the tubular article. These latter referred to smaller stitches form the area which will, in the finished blank be the bridge between the cup portions.

As knit, the tubular article defines an elongated artefact which if slit longitudinally would provide two identical lengths suitable for shaping into a brassiere blank. However, as hereinafter described, by retaining the initially knit integrity of the tubular article, a two-ply integrally knit and simultaneously shaped brassiere blank can be readily and economically constructed.

The use of the integral two-ply characteristics of the knit article provides many desirable effects. As herein-

after described, the tubular article allows for ease of stabilization; additional supportive characteristics and additionally provides a pocket between the plies allowing for the ready insertion therein of supplementary materials, such as padding, additional supporting elements, and/or fabric panels to control the opacity of the brassiere blank.

Aside from the other benefits effected, the longitudinal tubular knitting of the brassiere blank and the implementation in the finished brassiere of the tube as an integral two-ply frontal portion allows for the more ready construction of a diaphanous garment which is not only supportive but which may be conveniently and relatively economically produced.

As distinguished from the longitudinal selvege which extends along brassiere blank knit either on flat bed hosiery equipment or other knit single layer blanks, the tubular configuration of the present invention when incorporated in a garment does not have a longitudinal free edge. Thus, problems of raveling, curling or running are avoided and the blank need not require separate finishing operations along its longitudinal edges, such as the addition of bordering tapes or otherwise framing the outer longitudinal edges of the blanks.

As knit, the tubular article may be finished into a brassiere in a number of ways. As knit, the tubular article defines in general symmetry the basic brassiere constituents. By use of forms or the like the tubular article may be oriented such that the yarns are disposed to a desired finished shape. In view of the aforesaid deformation and stabilization characteristics of at least a portion of the yarns, the yarns may be then set to the desired brassiere shape. It should be noted that while the yarns are thus stabilized, such as by heat, they need not be rigidized. If desired, the yarns may be stabilized such that they have not reached their full extent of elongation, thus allowing the yarns to retain their subtleness and stretch characteristics. In other words, the yarns while stabilized need not be rigidized.

By selective use of stabilizable yarns and selectively rigidizing some areas and not others, support and control in desired areas of the blank can be imparted to a finished brassiere.

Stabilization may be effected by use of a wire form which is inserted longitudinally within the tubular knit article. The wire form flattens the tubular article into two superimposed layers of like configuration. The periphery of the wire form outlines the upper and lower base edges of the breast cups desired in the finished blank. The tubular article with such wire emplaced is then shaped by bust forms. As shaped the yarns are then stabilized, such as by subjecting the deformed tubular article to an environment adaptable for stabilization of the constituent yarns, for example, by hydrosetting the tubular article in an autoclave.

Since the wire form defines the longitudinal outline of the knitted article, the bust forms may be emplaced between the peripheral edges of the wire form. The bust forms thus simultaneously shape the superimposed layers of the knitted article into a two-ply brassiere blank.

After stabilization of the yarns the bust forms and wire form are removed and the resultant stabilized brassiere blank can be finished in any desired manner.

By implementation of a longitudinally knit tubular blank, knit by a successive program of larger and smaller stitches, a constant number of needles may be

employed throughout the entire knitting operation without the need for reciprocating actuation of the cylinder with its correlative use of only a selective percentage of needles for any period during the knitting cycle.

There is thus hereinafter more particularly described an article adapted for ready deformation into a two superimposed layer brassiere defining blank generally comprising a longitudinally knit seamless tubular artefact having successively knit portions of varying diameters in adjacent portions. Therefore, there is the same number of wales in each portion with the varying diameters being a function of the size of the stitches in each of the successively knit portions.

While the tubular knit article is described with respect to five zones or portions; to wit; a first dorsal portion, first cup portion, bridge, second cup portion and second dorsal portion, it should be understood that the dorsal portions may be omitted, with the knitting being only of the frontal area of a brassiere. If desired, dorsal portions may be later sewn to the frontal portion during finishing of the blank.

The preferred method of construction generally includes the steps of longitudinally knitting the seamless tubular artefact with the yarns adapted to be stabilized subsequent to knitting, deforming the two non-adjacent larger diameter portions of the artefact to a relatively semispherical shape, and stabilizing the yarns to retain the larger diameter non-adjacent portions as deformed.

Deformation is preferably accomplished by flattening the tubular artefact to position like knit portions into relative superimposition to form a seamless two layer artefact and three-dimensionally deforming the non-adjacent larger diameter portions into generally semispherical shape as superimposed.

The preferred apparatus for obtaining such superimposition includes a forming frame with a portion of the forming frame peripherally defining the upper and lower edges desired in the finished brassiere. This permits the emplacement of the tubular artefact with the forming frame emplaced therein over the three-dimensional bust forming units for deformation of the non-adjacent larger diameter portions of the artefact to three-dimensions as superimposed.

Although such novel feature or features believed to be characteristic of the invention are pointed out in the claim, the invention and the manner in which it may be carried out may be further understood by reference of the following description and the accompanying drawings.

FIG. 1 is a cross sectional, simplified depiction of the cylinder and associated mechanisms of a circular knit hosiery machine.

FIG. 2 is a schematic view of a tubular knit article of the present invention laid flat.

FIG. 2A is a top view of the tubular knit article of FIG. 2.

FIG. 3 is a plan view of a forming wire of the present invention.

FIG. 4 is an elevational view of another wire form of the present invention superimposed over a phantom depicting of a human female form.

FIG. 5 is a top plan view of a bust forming assembly of the present invention.

FIG. 6 is a sectional view taken along line 6-6 of FIG. 5.

FIG. 7 is a side elevational view illustrating a knitted article of the present invention having a forming wire emplaced therein as it is initially emplaced over the bust forms.

FIG. 8 is a plan view of an alternate forming wire of the present invention.

FIG. 9 is a side elevation of a bust supporting insert adaptable for use with a brassiere blank of the present invention.

FIG. 10 is a plan view illustrating the insert of FIG. 9 emplaced within a brassiere blank of the present invention.

FIG. 11 is a perspective view of a brassiere constructed in accordance with the teachings of the present invention as emplaced on the torso.

FIG. 12 is a schematic representation of the stitch diagram showing an alternate knitting sequence in accordance with the teachings of the present invention, with the diagram representing the tubular knit article as if cut longitudinally and laid flat.

FIG. 13 is a plan view of a form of a brassiere constructed in accordance with the present invention as laid flat.

Referring now to the figures in greater detail, where like reference numbers denote like parts in the various figures.

As hereinbefore described, the present invention employs a circular knit hosiery machine. Various circular knit hosiery machines are commercially available, such as a Scott & Williams 400 needle $3 \frac{3}{4}$ inch diameter circular knit hosiery machine. It is to be appreciated that such machine is merely exemplary of one machine readily suitable for use in knitting a seamless tubular artefact of the present invention and other machines, such as 200 needle circular knit hosiery machines or the like may also be employed.

FIG. 1 is a general depicting of a section of the cylinder 10 including a cylinder gear 11 having a bevelled edge 12 which mates with the driving mechanism (not shown) so as to rotate the cylinder 10 in the plane of the gear 11. A plurality of needles 13 seat within needle slots vertically disposed about the cylinder 10. At the base of the needles are butts 14 which ride along the periphery of cams 15. As the cylinder 10 rotates, the cams 15 selectively, vertically actuate a desired needle or needles 13 to a predetermined, sequential program which in combination with the sinker mechanism 16 of the machine forms a stitch. Where one yarn feed is employed, a single complete circumferential revolution of the cylinder, results in a course. Oftentimes two or more yarn feeds are employed so that two or more courses can be simultaneously knitted as the cylinder revolves. Thus, the circular knitting machine is in the nature of a weft knitting machine with the wales of the knit article extending longitudinally of the cylinder such as indicated by arrow A—A of FIG. 1 with the courses running transversally, circumferentially of the cylinder such as indicated by arrow B—B of FIG. 1.

The size of the knitted stitch can be varied in a number of ways. Oftentimes the circular knitting machine is provided with a control drum which regulates the stitch control cams, thus allowing a selective programming of stitch size for any knitting sequence. A like result can be obtained by controlling the tension of the yarn as it is fed to the needles with the yarn package feeding off yarn under selective various tensions.

Implementing whatever stitch size controlling device desired, the present invention provides for the knitting of a tubular article having preselected areas of varying stitch size. In FIGS. 2, 2A there is schematically illustrated a seamless tubular article 17 knit on the circular knit hosiery machine. It will be noted that there are five definitive areas or portions of the tubular article 17. All portions are knit with the same number of needles, that is on a 400 needle machine, there is a constant number of wales (i.e., 400) throughout all portions of the seamless tubular knit article 17. The variation in the diameter of the portions is dictated by the size of the stitches.

Portion A represents a plurality of courses knit where the stitch size is relatively small. This portion A represents a first dorsal or side portion of the knitted blank. Therefore the number of courses required in portion A is determined by the girth of the wearer. Since it is oftentimes desirable, in finishing a garment to provide separate dorsal panels which are sewn on to the basic front of the brassiere garment, only a small number of courses may be knit for the portion A.

Portion B represents that area of the tubular knit article 17 which will act as a first breast cup. The stitches in portion B are larger than those in portion A with the stitch size controlled as heretofore described. The number of courses knit will of course vary based upon the desired cup size and yarn denier.

Portion C of FIG. 2 represents the area which, in a finished garment will be the bridge between the cups of the brassiere. Smaller stitches, comparable to those knit for portion A are knit in this area. The number of courses for portion C can be selectively chosen based upon the size of the brassiere, the denier of the yarns and the dictates of fashion.

Portion D represents the second cup area and is knit in the same manner as hereinbefore described with respect to portion B. Similarly, portion E represents the second dorsal portion on the opposite side of the knit article 17 and its stitch size is the same as in portion A.

It will be noted that only two stitch sizes are necessary with it being possible for portions A, C and E to be knit having stitches of equal size and portions B and D being knit of stitches having equal size. While it is possible to graduate the difference in stitch size, for example between portions A & B, the same is not required. While the representation of the knit article 17 schematically illustrated in FIG. 2 indicates rather severe angles at the point where the size of the stitches is varied, in actually knitting the tubular article 17 it will be found that the area where the stitch size is varied does not in fact, provide the severe angular disparity depicted in FIG. 2 but rather there is a degree of puckering (shown in phantom in FIG. 2) due to the abrupt change in yarn density per unit area.

While various yarns may be employed in knitting depending upon the texture and denier desired in the finished garment the yarns are stabilizable, preferably heat setting, that is the yarns are deformable yet subject to stabilization by subjecting the yarns to heat. Various yarns of this nature are readily available, for example, thermoplastic yarns such as nylon, polyester or the like. Thus, the seamless tubular knitted article 17 of FIGS. 2, 2A is deformable and may be further shaped, separate and apart from the initial knitting to provide semi-spherical contouring to the cup portions.

While various methods may be suitably employed, the following described method and apparatus has been

found highly suitable for the finishing of the greige tubular article 17.

After knitting, the seamless tubular knit article 17 is scoured and dyed. The scouring performs two functions. It first purges the knitted blank of any impurities which may have been carried on the yarn. Additionally, the washing, generally relaxes any tension which may have been induced through knitting.

After scouring and dyeing a forming wire 18 such as shown in FIG. 3 is emplaced within the hollow chamber formed by the tubular knitting. The forming wire 18 generally defines the peripheral two-dimensional shape desired in the finished garment. This can be seen most clearly in FIG. 4 where an alternate forming wire 19 is illustrated superimposed over the upper portions of the female torso.

In FIG. 3 the forming wire 18 is constructed of a length of wire formed or bent so as to define within the area enclosed by the wire the pectoral region of the torso and end lengths defining the dorsal portions. When emplaced within the tubular knit article 17, the tubular knit article 17 is distended so as to lie relatively flat. To aid in the emplacement, the ends of the forming wire 18 may be provided with a locking hinge 20, generally including a pivot 21 and a locking pin 22. The locking pin includes along its vertical side a mating groove 23 which fits over one end of the forming wire 18. With the pivot 21 affixed to one end of the forming wire 18 and the mating groove 23 engaging the other end of the forming wire 18, the forming wire 18 may be locked into a predetermined shape with the distal ends 36, 37 of the forming wire 18 in a given relationship, shown in FIG. 3 as a parallel spaced apart relationship. When the mating groove 23 is disengaged, the distal ends 36, 37 of the forming wire 18 may be brought together thus reducing the longitudinal height of the forming wire 18 and allowing for its more ready insertion inside the tubular seamless knit article 17.

The forming wire 19 of FIG. 4 includes the same general features of the forming wire 18 of FIG. 3, however it should be noted that the forming wire 19 has been shaped not only to peripherally define the general pectoral area, but additionally provides peaked or somewhat triangular shaping areas 24. The triangular shaping area 24 serve as anchoring areas or platforms for the ready affixation of brassiere straps or the like to the finished blank in the formation of the brassiere.

Once a forming wires 18 has been emplaced within the chamber formed by the tubular seamless knit article 17 those portions of the blank B, D which define the bust receiving elements are subject to deformation by three-dimensional forms 25. The forms 25 are preferably part of a integral unit having a base 26 with selectively shaped and spaced apart bust defining forms 25. The lower periphery of the forms 25 define an area slightly smaller than the area formed by the inside periphery of the forming wire 18 in the cup region.

Thus as shown in FIG. 7 the forms 25 may be emplaced within the wire form so that the base of the forms 25 will enter within the forming wire 18. As clearly shown in FIG. 7 the tubular seamless article 17 is deformed in a manner so as to provide a two-ply blank.

As deformed by the three-dimensional forms 25, and with the forming wire 18 therein, the tubular knit article 17 is subjected to an environment which will stabilize the yarns as oriented. It has been found that hydro-

setting in an autoclave under selective pressures and temperatures stabilizes the yarns. For example, if the yarns are four ends of 20 denier nylon (i.e., a total of 80 denier) hydrosetting for two minutes at 115 degrees centigrade at two atmospheres stabilizes the yarns.

Once stabilized, the three-dimensional forms are removed as is the forming wire and the resultant brassiere blank is ready for finishing as a brassiere. For example, closure means such as hook and eye arrangements can be attached to the dorsal end portions and straps can be affixed between the upper portion of the cups and the rear closure.

Since the human body is tapered much like an inverted cone in the upper torso area, it is desirable that the blank be pitched, that is the dorsal portions should extend angularly from the outer cup edges so that the brassiere when laid flat is somewhat arc shaped. As illustrated in FIG. 13 this arc shaping or pitching can be effected after the knitting, deformation and stabilization of the tubular knit article 17 such as by substituting sewn side panels 38 along the outer cup edges in lieu of the integrally knit dorsal portions and finishing the brassiere such as by the addition of straps 39, rear hooks 40 and eyes 41 closure means and an underbust band 42. It is possible however, to pre-orient the tubular knit article 17 prior to stabilization to effect such arc shaping. Thus, as shown in FIG. 8, the forming wire 27 may be preshaped so as to have angularly disposed lateral side portions 28 pitched to the angle desired for the finished blank. It should be noted that in the lower portion of the forming wire 27 the arcuate shaping of the forming wire has been eliminated thus modifying the cup shape.

As hereinbefore described, the tubular knit article 17 as deformed and stabilized provides a two-ply brassiere blank. If desired, the blank may then be longitudinally halved along the lines defined by the forming wire 18. Thus, two blanks may be made of the single seamless tubular knit article. However, it is preferred that the two-ply resultant blank be employed in a single garment.

In addition to the additional supportive features of a two-ply construction, the two-ply in the finished garment provides an integral chamber which can be employed as a receptacle for supportive or decorative variations. For example, FIGS. 9 and 10 illustrate a push-pad 29 (FIG. 9) which, when emplaced within the two-ply brassiere blank 30 adds supportive and shaping means to the garment, with the padding 29 or other desired accessory retained within the two-ply nature of the blank.

In FIG. 11 the two-ply brassiere blank 30 is shown as finished into a brassiere. The shoulder straps 31 have been affixed to the garment and the dorsal panels 32 encircle the torso having closure means (not shown). Of course, any desired ornamentation may be applied either after the knitting and shaping of the brassiere blank, or through the implementation of equipment generally available with or integral to circular knit hosiery machines, specific stitch patterns having desirable visual effects can be integrally knit into the tubular knit article 17.

While the primary shaping of the brassiere blank is effected through the combined use of the basic knitting program hereinbefore described with the forming techniques illustrated, various knitting programs may be employed to add supportive features to the finished

garment especially in the areas which will define the cups. FIG. 12 illustrates a knitting sequence which not only adds supportive characteristics, but further provides an inherent prediliction of the tubular knit article to properly shape itself with the aid of the forming wire and the bust forms into breast cups.

The knitting diagram illustrated, represents the tubular knit article as if cut open and laid flat. Thus, the width of the diagram is equivalent to the total number of needles of the machine. The areas denoted as F, G, H, I and J represent respectively, a portion of the back panel or dorsal panel; the cup portion; the bridge between the cups; the second cup; and the opposite dorsal panel.

Since FIG. 12 is a stitch diagram, the width of areas F, H and J are shown equal to that of G and I. In stitch form this is true since all areas in the exemplary diagram each contain the same number of wales. However, as heretofore described, the stitch sizes in areas F, H and J are smaller than that in G and I. It will be noted that there is generally defined in each area G and I a diamond shape arrangement 33 which define four somewhat triangular areas 34. The knitting diagram proscribes the use of two different types of yarn. The basic yarn used throughout the tubular knitted article have been pre-stabilized to a given degree. However, in the triangular area 34 additional yarns are added. This may be readily accomplished by plating to the primary base yarn another stabilizable yarn distinguished as distiguished from the base yarn has not been pre-stabilized to the same degree as the base yarn.

It will therefore be noted, that there is additional yarn in the areas 34 which, in the finished garment will represent the major portion of the undercup area. Further, after knitting, as aforedescribed, the tubular knit article 17 is scoured. The presence of heat during scouring will shrink the non or lesser stabilized yarns in the triangular areas 34 to a greater degree than the shrinkage which will occur in the base yarn. For ease in understanding, points 35 have been indicated in the knitting diagram. These are not knitting indicia but rather, have been indicated, for purposes of pointing out the general locations of the apex or nipple areas in each ply in the cup areas.

It should be noted that the shape of the plated yarn areas 34 is such, that aside from reinforcement, the contouring imparted during shrinkage provides not only a rounding in the undercup area but an anatomical conformance along the side area of the cup.

It should also be noted that the diamond shape does not extend completely circumferentially about the tubular article. Rather, a border is left which, in the finished garment provides a ready location for an underbust band or the like such as shown as 42 in FIG. 13.

It is to be appreciated that the above terms and expressions are employed as terms of description recognizing that various modifications are possible.

Having thus described certain forms of the invention in some detail, what is claimed is:

1. An article adapted for deformation into a two superimposed layer brassiere defining blank, comprising; a longitudinally knit, seamless tubular sleeve, successively knit portions of said sleeve having a varying diameter than that of its next adjacent portion; at least two non-adjacent portions of equal diameter to each other defining the frontal portion of said

blank with said two non-adjacent portions defining locations adapted for deformation into breast receiving elements;

said breast receiving elements being of a larger than the balance of said frontal portion;

said sleeve, when collapsed, providing at each of said breast defining locations a two-ply arrangement with each ply the substantial equivalent of the other.

2. The article as claimed in claim 1 wherein said sleeve includes the same number of wales in each of said successively knit portions.

3. The article as claimed in claim 1 wherein said successive portions include at least a first portion having a first diameter, a second portion having a second diameter smaller than said first diameter and a third portion having a third diameter equal to said first diameter wherein said first and third portions define said locations on said article adaptable for deformation into breast receiving elements.

4. The article as claimed in claim 3 further including a fourth portion preceding said first portion, and a fifth portion succeeding said third portion wherein said fourth and fifth portions have a diameter smaller than said first and third portions.

5. The article as claimed in claim 1 wherein said varying diameters are a function of the size of the stitches in each of said successively knit portions.

6. A brassiere comprising a knit frontal portion having two breast receiving portions spaced apart by a bridge portion, body encircling means extending between the outer edges of said frontal portion, wherein said breast receiving portion and said bridge are a collapsed deformed tubular sleeve including the same number of wales throughout their extent, with each of said frontal portion a two-ply arrangement with each ply of each breast receiving portion the substantial equivalent of the other ply of such portion, each of said breast receiving portions of a larger diameter than the balance of said frontal portion.

7. A brassiere comprising a knit frontal poeition having two non-adjacent breast receiving portions spaced apart by a bridge portion, body encircling means extending between the outer edges of said frontal portion, wherein said frontal portion comprises a longitudinally knit seamless two-ply extent having successively knit portions of varying diameters in adjacent portions, at least two non-adjacent portions of substantially equal diameter, said last referred to two non-adjacent portions defining said two breast receiving portions said two breast receiving portions of a larger diameter than the balance of said frontal portion.

8. The brassiere as claimed in claim 7 further including insert means, said insert means emplaced between said two plies.

9. A brassiere comprising a frontal portion having two breast receiving cup portions spaced apart by a bridge portion, and body encircling means extending between the outer edges of said frontal portion, wherein said frontal portion comprises a longitudinally extending collapsed tubular seamless member forming a two-ply extent between at least said body encircling means, said breast receiving cups being of a deformed wider diameter than said bridge portion.

* * * * *