



US00D886943S

(12) **United States Design Patent**  
**Slamans**

(10) **Patent No.:** **US D886,943 S**

(45) **Date of Patent:** **\*\* Jun. 9, 2020**

- (54) **NOZZLE**
- (71) Applicant: **Outdoor Trading LLC**, Sheridan, WY (US)
- (72) Inventor: **Andrew Slamans**, Hershey, PA (US)
- (73) Assignee: **OUTDOOR TRADING LLC**, Sheridan, WY (US)
- (\*\*) Term: **15 Years**
- (21) Appl. No.: **29/685,496**

- D418,590 S \* 1/2000 Tracy ..... D23/213
  - D439,636 S \* 3/2001 Hamilton ..... D23/213
  - 6,435,567 B2 \* 8/2002 Kikumori ..... F16L 25/0036  
285/319
  - D462,256 S \* 9/2002 Jaynes ..... D12/160
  - 6,499,771 B1 \* 12/2002 Snyder, Sr. .... F16L 37/0915  
285/319
  - D574,931 S \* 8/2008 Hughes ..... D23/262
  - D595,420 S \* 6/2009 Suzuki ..... D24/227
  - D595,421 S \* 6/2009 Suzuki ..... D24/227
  - D595,863 S \* 7/2009 Suzuki ..... D24/227
  - D627,432 S \* 11/2010 Escoto, Jr. .... B05B 7/066  
D23/213
  - D638,104 S \* 5/2011 Govoni ..... D23/262
- (Continued)

- (22) Filed: **Mar. 28, 2019**
- (51) **LOC (12) Cl.** ..... **23-01**
- (52) **U.S. Cl.**  
USPC ..... **D23/213**
- (58) **Field of Classification Search**  
USPC ..... D23/213, 214, 215, 223, 224, 226, 229,  
D23/230  
CPC ..... A61H 9/0021; A61H 33/00; B05B 1/00;  
B05B 1/14; B05B 1/185; B05B 1/08;  
B05B 1/02; B05B 1/26; B05B 12/002;  
B05B 1/18; B05B 9/01  
See application file for complete search history.

OTHER PUBLICATIONS

[https://www.amazon.com/2wayz-Garden-Valve-Running-Experience/dp/B00R1RX4JO/ref=pd\\_rhf\\_dp\\_p\\_img\\_2?\\_encoding=UTF8&psc=1&refRID=GXNK1E5QSQM9X7F6JYT8](https://www.amazon.com/2wayz-Garden-Valve-Running-Experience/dp/B00R1RX4JO/ref=pd_rhf_dp_p_img_2?_encoding=UTF8&psc=1&refRID=GXNK1E5QSQM9X7F6JYT8) (Year: 2015).\*

*Primary Examiner* — Manpreet S Matharu  
*Assistant Examiner* — Keith J Wilson  
(74) *Attorney, Agent, or Firm* — DLA Piper LLP (US)

(57) **CLAIM**

The ornamental design for nozzle, as shown and described.

(56) **References Cited**

U.S. PATENT DOCUMENTS

- D221,651 S \* 8/1971 Napper ..... D23/259
- D229,496 S \* 12/1973 Hand ..... D23/262
- 4,827,539 A \* 5/1989 Kiziah ..... E03D 11/16  
285/303
- 4,899,938 A \* 2/1990 Havrilla, Jr. .... B05B 7/0815  
239/294
- D319,291 S \* 8/1991 Hanzel ..... D23/212
- D349,758 S \* 8/1994 Hallbach ..... D23/259
- D364,916 S \* 12/1995 Hallbach ..... D23/259
- 5,799,364 A \* 9/1998 Foisy ..... A47L 5/24  
15/338
- D402,354 S \* 12/1998 Strong ..... D23/259
- 5,996,134 A \* 12/1999 Senninger ..... E03D 11/16  
138/96 R

**DESCRIPTION**

FIG. 1 is a perspective view of the nozzle showing my new design;  
FIG. 2 is a front side view of the nozzle;  
FIG. 3 is a back side view of the nozzle;  
FIG. 4 is a left side view of the nozzle;  
FIG. 5 is a right view of the nozzle;  
FIG. 6 is a top view of the nozzle; and,  
FIG. 7 is a bottom view of the nozzle.  
The broken lines shown represent portions of a nozzle and form no part of the claimed design.

**1 Claim, 6 Drawing Sheets**

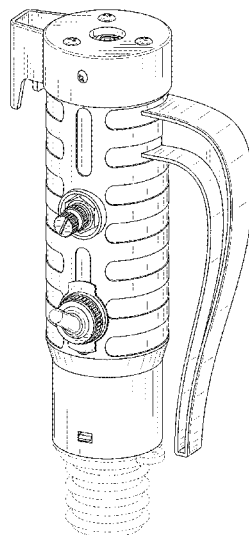

(56)

References Cited

U.S. PATENT DOCUMENTS

D646,762	S *	10/2011	Terry	D23/259	D857,179	S *	8/2019	Thompson	D23/259
D670,786	S *	11/2012	Mauchle	D23/213	D859,604	S *	9/2019	Dagdelen	D23/259
8,474,878	B2 *	7/2013	Richter	F16B 2/246 285/319	D861,054	S *	9/2019	Avila	D15/199
D689,590	S *	9/2013	Brose	D23/213	D865,919	S *	11/2019	Lippka	D23/262
D704,312	S *	5/2014	Kuo	D23/259	D868,112	S *	11/2019	Tsuji	D15/5
D717,405	S *	11/2014	Coronado	D23/259	2003/0062428	A1 *	4/2003	Baasch	F02M 25/00 239/407
D717,406	S *	11/2014	Stanley	D23/259	2004/0080160	A1 *	4/2004	Rief	E04H 4/1654 285/276
8,910,677	B1 *	12/2014	Carpenter	B60K 15/04 141/312	2006/0006651	A1 *	1/2006	Watanabe	F16L 25/0036 285/247
D737,410	S *	8/2015	Wyne	D23/259	2007/0228727	A1 *	10/2007	Matsuno	F16L 37/0985 285/305
D738,470	S *	9/2015	Eaton	F16L 21/08 D23/259	2012/0325335	A1 *	12/2012	Schalkx	F16L 37/2445 137/315.01
D782,621	S *	3/2017	Smith	D23/259	2014/0327238	A1 *	11/2014	Bowman	F16L 21/08 285/112
D784,495	S *	4/2017	Pearson	D23/249	2014/0338773	A1 *	11/2014	French	F16L 37/1225 138/109
9,623,594	B2 *	4/2017	French	F16L 21/03	2015/0060577	A1 *	3/2015	Kosovich	B05B 13/0627 239/587.1
D806,833	S *	1/2018	Pearson	D23/249	2015/0176728	A1 *	6/2015	Bowman	F16L 21/065 285/309
D813,355	S *	3/2018	Weatherby	D23/259	2015/0353340	A1 *	12/2015	Gammon	B64D 37/00 141/1
D815,516	S *	4/2018	Karmarkar	D8/382	2017/0328500	A1 *	11/2017	Bowman	F16L 17/04
D816,811	S *	5/2018	Dagdelen	D23/259	2017/0328505	A1 *	11/2017	Sith	F16L 37/0915
D823,443	S *	7/2018	Bancroft	D23/262	2017/0334705	A1 *	11/2017	Murugo Perez	B67D 7/06
D830,522	S *	10/2018	Di Liberto	D23/259	2018/0156362	A1 *	6/2018	Takeda	B25B 27/10
D833,581	S *	11/2018	Atwell	D23/259	2018/0163905	A1 *	6/2018	Ohnemus	F16L 21/005
D835,756	S *	12/2018	Auxter	D23/249	2018/0209567	A1 *	7/2018	Brandt	F16L 17/04
D836,755	S *	12/2018	Dale	D23/259	2018/0304179	A1 *	10/2018	Auxter	B01D 27/06
D844,113	S *	3/2019	Auxter	D23/249	2018/0326449	A1 *	11/2018	Dale	B05C 17/00513
D847,309	S *	4/2019	Sugatani	D23/259					
D849,890	S *	5/2019	Tempel	D23/233					
D851,220	S *	6/2019	Thompson	D23/259					
D851,738	S *	6/2019	Ghorbani	D23/259					
D852,934	S *	7/2019	Habres	D23/259					
D855,781	S *	8/2019	Delancey	D23/259					

\* cited by examiner

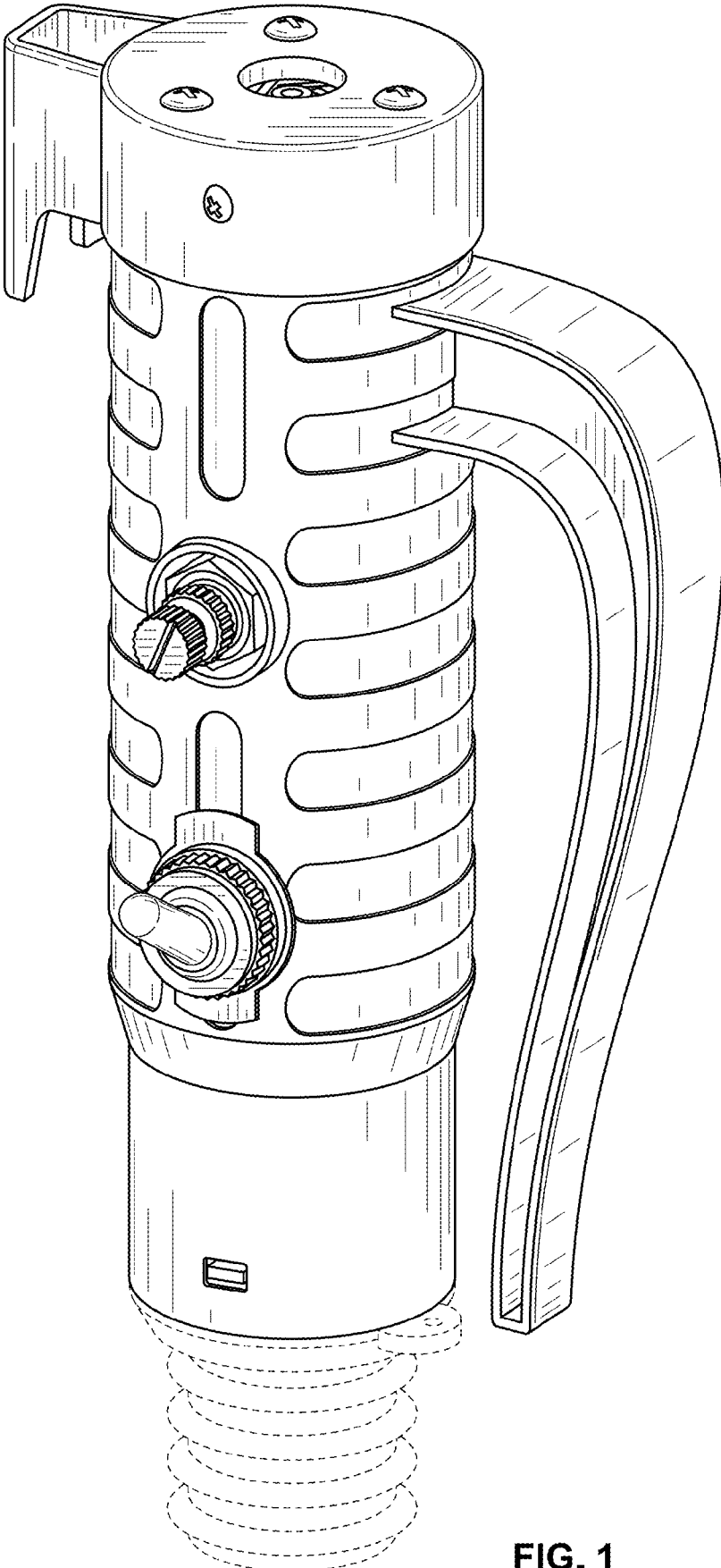

FIG. 1

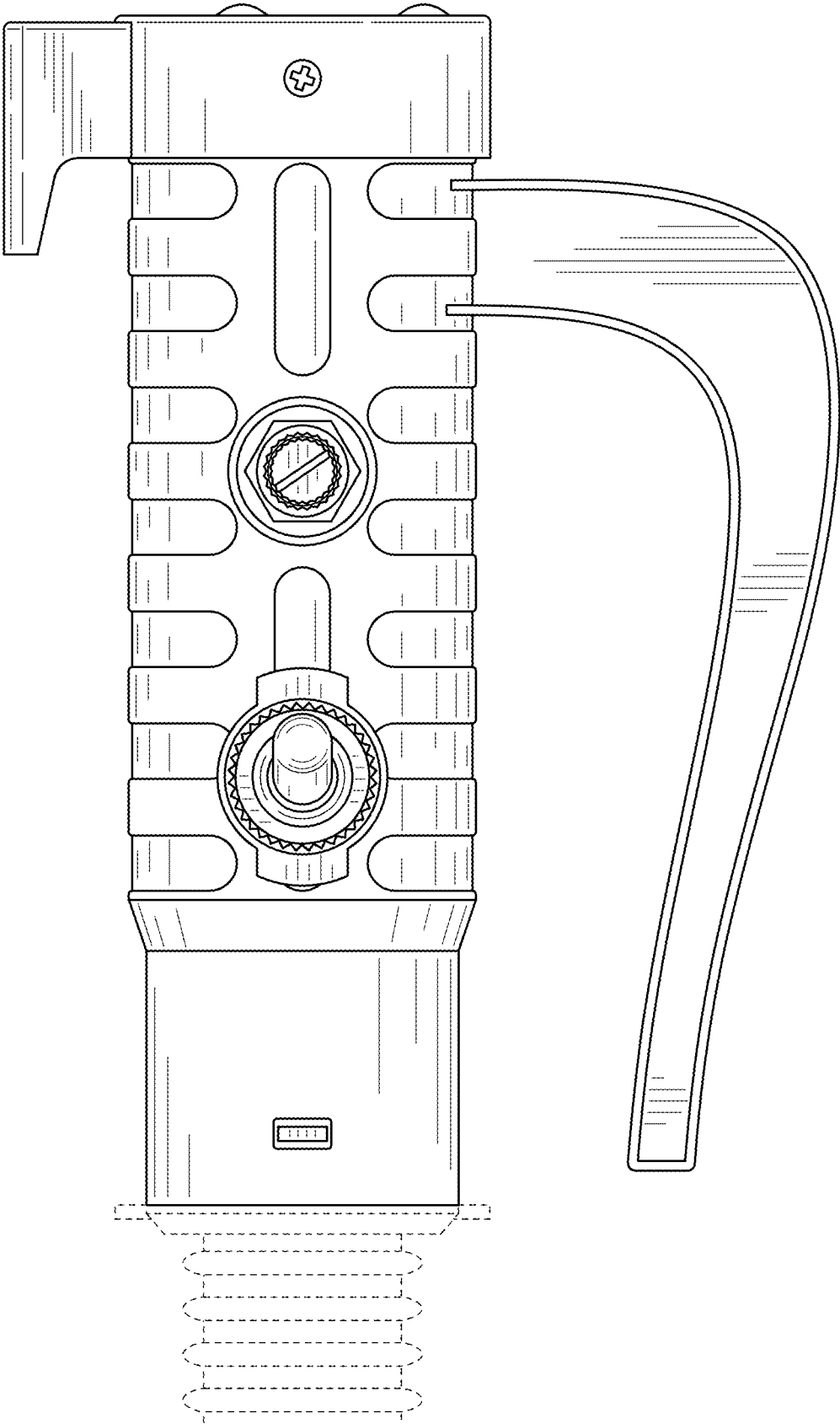

FIG. 2

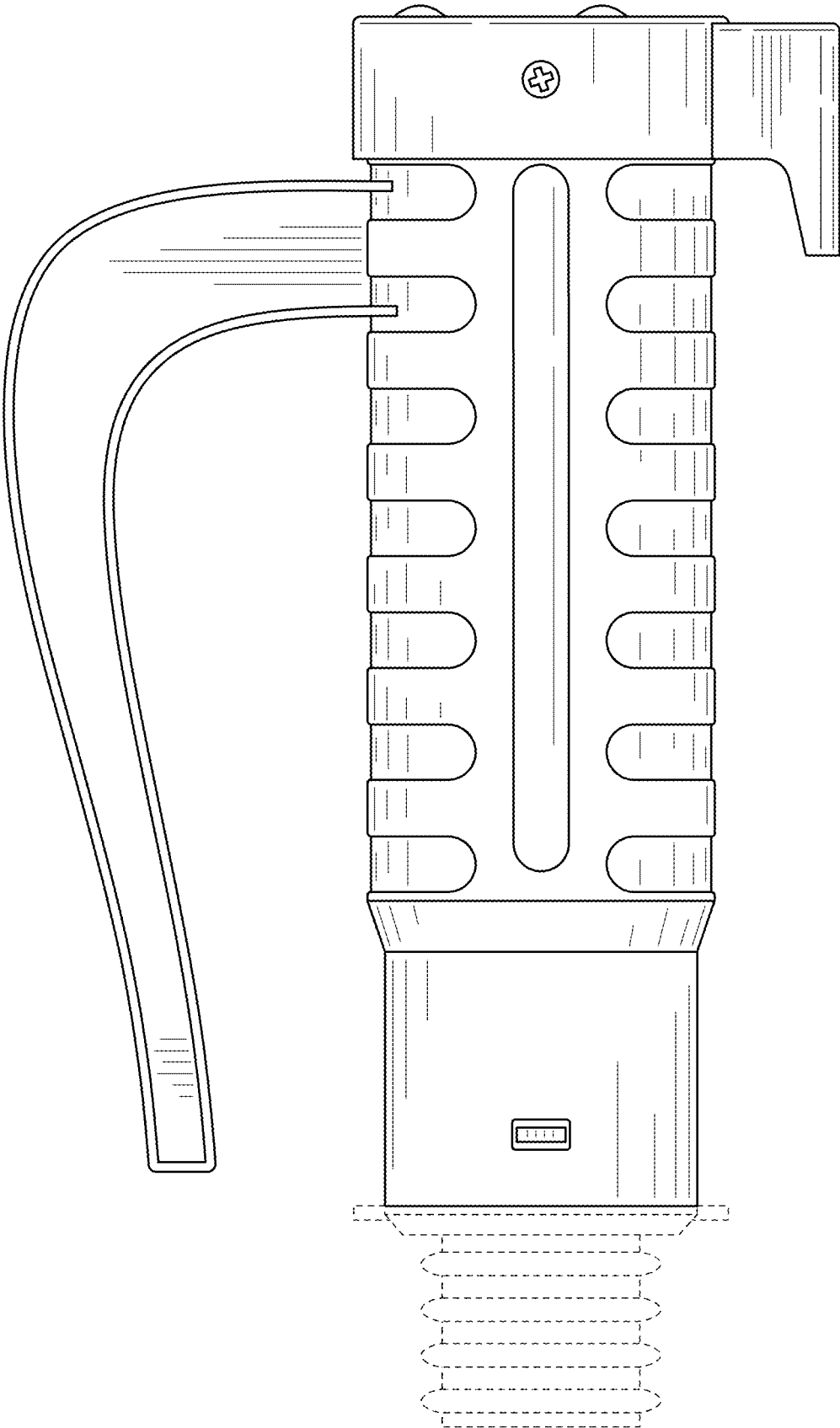

FIG. 3

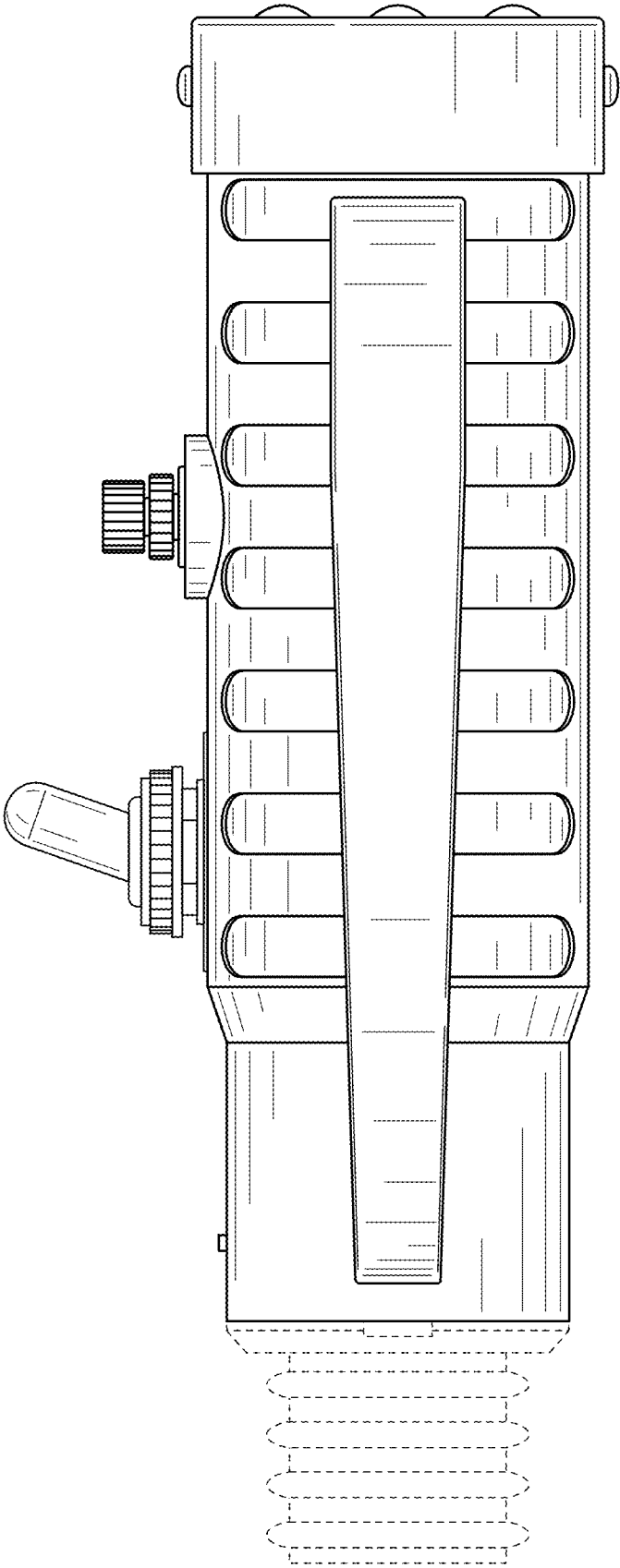

FIG. 4

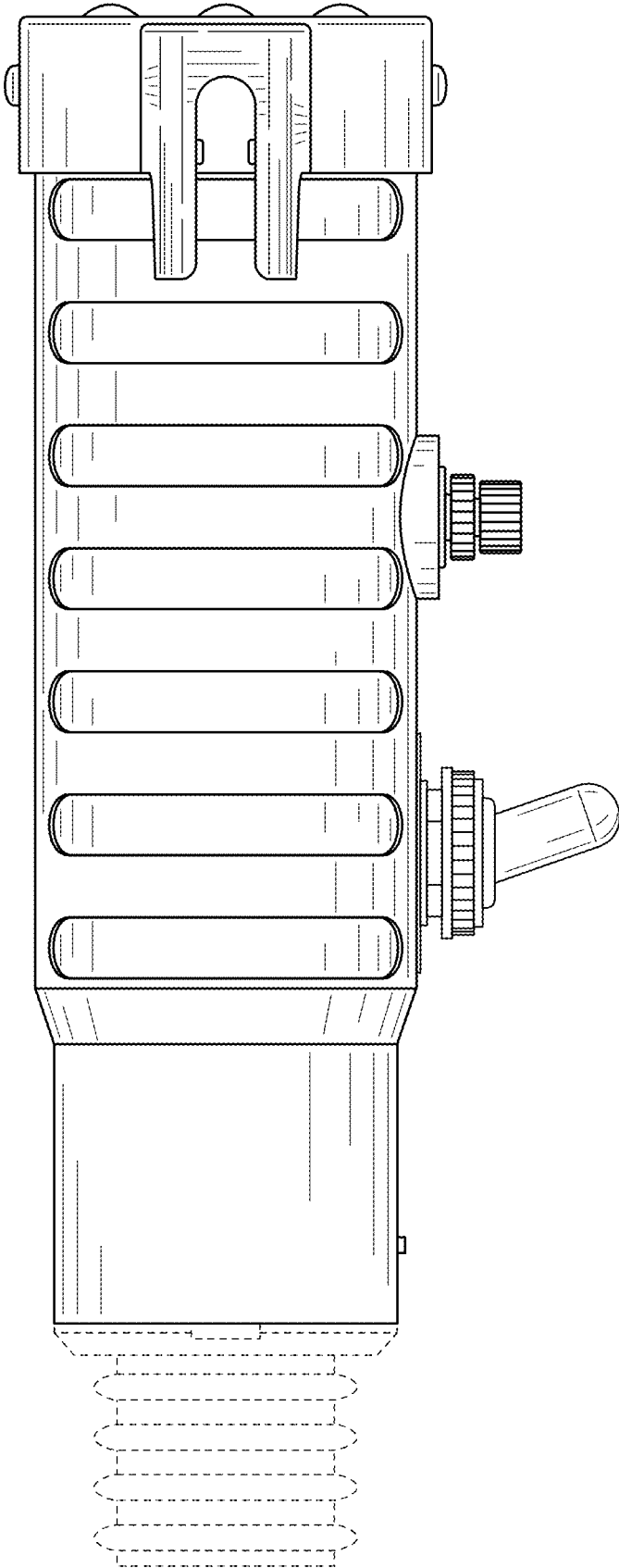

FIG. 5

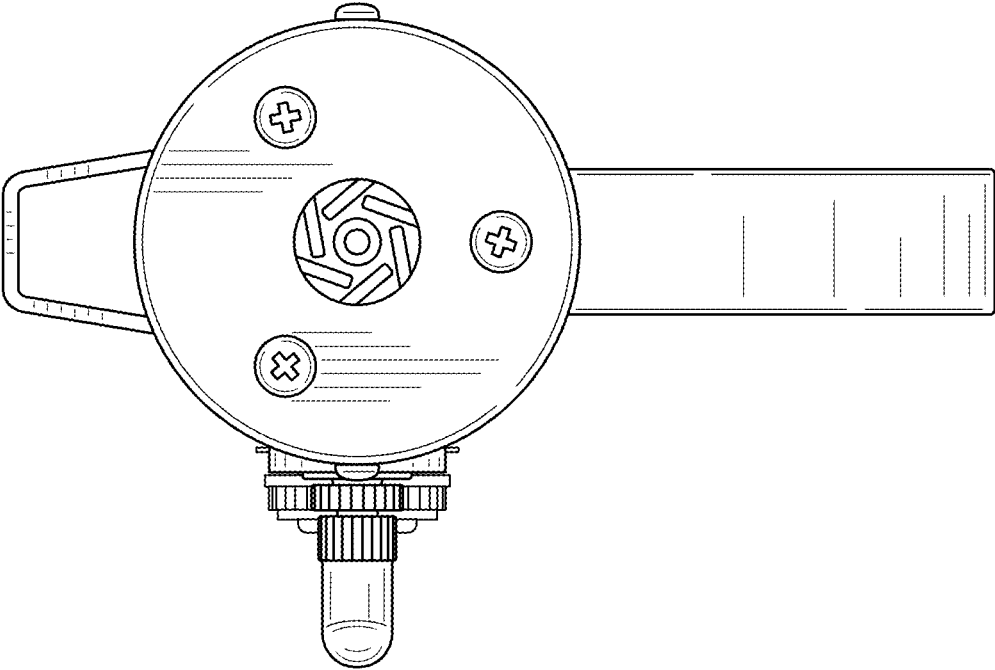

FIG. 6

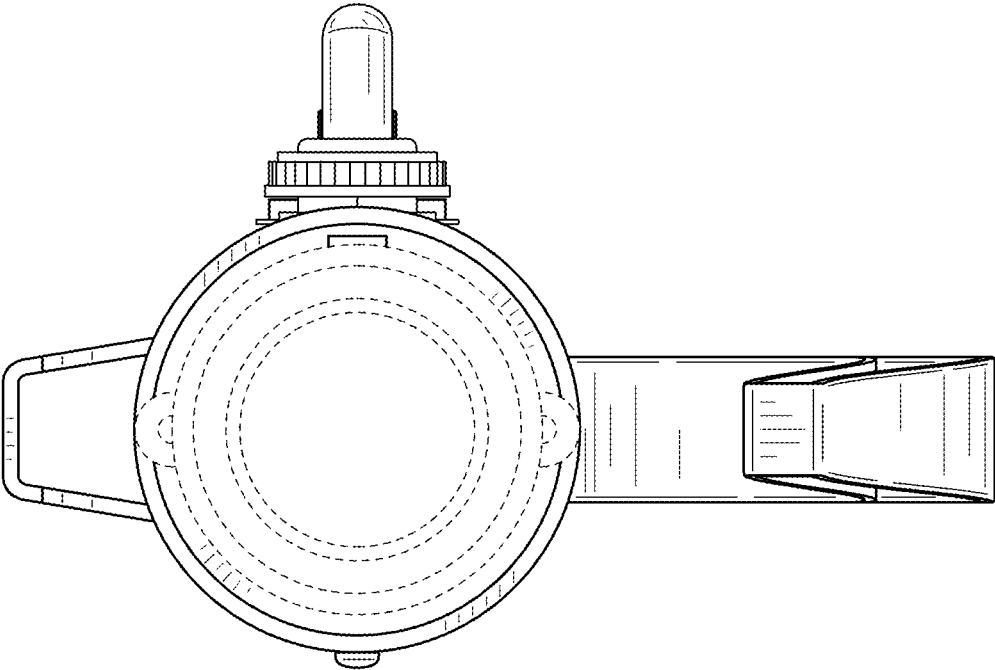

FIG. 7