



(51) International Patent Classification:

H01Q 21/28 (2006.01) *H01Q 9/28* (2006.01)
H01Q 21/26 (2006.01)

(21) International Application Number:

PCT/US2018/030606

(22) International Filing Date:

02 May 2018 (02.05.2018)

(25) Filing Language:

English

(26) Publication Language:

English

(30) Priority Data:

62/528,611 05 July 2017 (05.07.2017) US

(71) Applicant: **COMMSCOPE TECHNOLOGIES LLC**
[US/US]; 1100 CommScope Place SE, Hickory, North Carolina 28602 (US).

(72) Inventors: **ISIK, Ozgur**; Unit 404/2 The Piazza, Wentworth Point, New South Wales 2127 (AU). **DUGGAL, Hemanshu**; 5 Blundell Street, Marsfield, New South Wales 2122 (AU).

(74) Agent: **AYERS, Randal**; Myers Bigel, P.A., P.O. Box 37428, Raleigh, North Carolina 27627 (US).

(81) Designated States (*unless otherwise indicated, for every kind of national protection available*): AE, AG, AL, AM,

AO, AT, AU, AZ, BA, BB, BG, BH, BN, BR, BW, BY, BZ, CA, CH, CL, CN, CO, CR, CU, CZ, DE, DJ, DK, DM, DO, DZ, EC, EE, EG, ES, FI, GB, GD, GE, GH, GM, GT, HN, HR, HU, ID, IL, IN, IR, IS, JO, JP, KE, KG, KH, KN, KP, KR, KW, KZ, LA, LC, LK, LR, LS, LU, LY, MA, MD, ME, MG, MK, MN, MW, MX, MY, MZ, NA, NG, NI, NO, NZ, OM, PA, PE, PG, PH, PL, PT, QA, RO, RS, RU, RW, SA, SC, SD, SE, SG, SK, SL, SM, ST, SV, SY, TH, TJ, TM, TN, TR, TT, TZ, UA, UG, US, UZ, VC, VN, ZA, ZM, ZW.

(84) Designated States (*unless otherwise indicated, for every kind of regional protection available*): ARIPO (BW, GH, GM, KE, LR, LS, MW, MZ, NA, RW, SD, SL, ST, SZ, TZ, UG, ZM, ZW), Eurasian (AM, AZ, BY, KG, KZ, RU, TJ, TM), European (AL, AT, BE, BG, CH, CY, CZ, DE, DK, EE, ES, FI, FR, GB, GR, HR, HU, IE, IS, IT, LT, LU, LV, MC, MK, MT, NL, NO, PL, PT, RO, RS, SE, SI, SK, SM, TR), OAPI (BF, BJ, CF, CG, CI, CM, GA, GN, GQ, GW, KM, ML, MR, NE, SN, TD, TG).

Published:

— *with international search report (Art. 21(3))*

(54) Title: BASE STATION ANTENNAS HAVING RADIATING ELEMENTS WITH SHEET METAL-ON DIELECTRIC DIPOLE RADIATORS AND RELATED RADIATING ELEMENTS

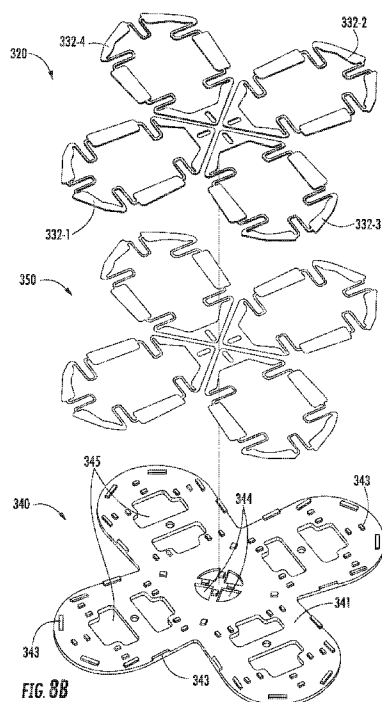

(57) Abstract: A radiating element for a base station antenna includes a feed stalk and a cross-dipole radiator mounted thereon. The cross-dipole radiator includes a dielectric mounting substrate, a first metal dipole that extends along a first axis on the dielectric mounting substrate, a second metal dipole that extends along a second axis on the dielectric mounting substrate that is generally perpendicular to the first axis, and an adhesive layer between the dielectric mounting substrate and the first and second metal dipoles.



BASE STATION ANTENNAS HAVING RADIATING ELEMENTS WITH SHEET
METAL-ON DIELECTRIC DIPOLE RADIATORS AND RELATED RADIATING
ELEMENTS

CROSS-REFERENCE TO RELATED APPLICATION

[0001] The present application claims priority to U.S. Provisional Patent Application Serial No. 62/528,611, filed July 5, 2017, the entire content of which is incorporated by reference herein.

BACKGROUND

[0002] The present invention generally relates to radio communications and, more particularly, to base station antennas for cellular communications systems.

[0003] Cellular communications systems are well known in the art. In a cellular communications system, a geographic area is divided into a series of regions that are referred to as "cells." Each cell may be served by a respective base station. Each base station may include one or more base station antennas that are configured to provide two-way radio frequency ("RF") communications with fixed and mobile subscribers (or "users") that are located within the cell served by the base station. In many cases, a base station may be divided into "sectors." For example, in one common configuration, a hexagonally shaped cell is divided into three 120° sectors in the azimuth plane (i.e., the plane defined by the horizon) and each sector is served by one or more base station antennas to provide full 360° coverage in the azimuth plane.

[0004] Each base station antenna may include one or more vertically-oriented linear arrays of radiating elements. Each linear array of radiating elements may generate a radiation pattern (also referred to herein as an "antenna beam") that is directed outwardly in the general direction of the horizon. In some cases two or more of the vertically-oriented linear arrays of

radiating elements may be designed to work together to generate a single (narrower) antenna beam. Multiple linear arrays of radiating elements may be provided on a base station antenna to, for example, provide cellular service in multiple frequency bands and/or to reduce the azimuth beamwidth of the antenna beam. The number of radiating elements in each linear array is typically based on a desired beamwidth in the elevation plane, where the elevation beamwidth refers to the angular extent of the antenna beam along an axis that is perpendicular to the azimuth plane.

[0005] The radiating elements of each linear array are most typically implemented as dipole radiating elements, although other types of radiating elements such as patch radiating elements are sometimes used. Most base station antennas now use radiating elements that employ cross-dipole radiators that have first and second dipoles that are arranged to transmit/receive RF signals at orthogonal polarizations. The slant $-45^{\circ}/+45^{\circ}$ cross-dipole radiator approach is most typically used, where one of the dipoles transmits and receives at a first linear polarization that is arranged at an angle of -45° with respect to the longitudinal axis of the linear array, while the other one of the dipoles transmits and receives at a second linear polarization that is arranged at an angle of $+45^{\circ}$ with respect to the longitudinal axis of the linear array. Both dipoles are typically mounted in front of and parallel to a ground plane such as metal reflector that is coupled to electrical ground. Typically, the dipoles are mounted at a distance of about 0.16λ to 0.25λ above the ground plane, where λ is the wavelength corresponding to a center frequency of the frequency band at which the radiating element is designed to operate.

[0006] Radiating elements are known in the art that have dipole radiators formed using metal rods, sheet metal, printed circuit boards, and a variety of other materials. As multi-band base station antennas have been introduced that include two or more linear arrays of radiating elements that operate in different frequency bands, the designs of the dipole radiators have tended to become more complicated, in an effort to decouple the radiating elements of different frequency bands as much as possible. The dipole radiators of these radiating elements are often implemented using printed circuit boards.

BRIEF DESCRIPTION OF THE DRAWINGS

[0007] **FIG. 1** is a front perspective view of a base station antenna according to embodiments of the present invention.

[0008] **FIG. 2** is a perspective view of a base station antenna of **FIG. 1** with the radome removed.

[0009] **FIG. 3** is a front view of a base station antenna of **FIG. 1** with the radome removed.

[0010] **FIG. 4** is an enlarged partial perspective front view of the base station antenna of **FIGS. 1-3**.

[0011] **FIG. 5** is an enlarged perspective view of one of the low-band radiating element assemblies of the base station antenna of **FIGS. 1-4**.

[0012] **FIG. 6** is a front view of the low-band radiating element assembly of **FIG. 5**.

[0013] **FIG. 7** is a side view of the low-band radiating element assembly of **FIG. 5**.

[0014] **FIGS. 8A** and **8B** are a perspective view and an exploded perspective view, respectively, of the cross-dipole radiator of one of the low-band radiating elements included in the low-band radiating element assembly of **FIGS. 5-7**.

[0015] **FIGS. 9A-9B** are a front view and a rear view, respectively, of the dielectric mounting substrate of the cross-dipole radiator of **FIGS. 8A-8B**.

[0016] **FIG. 10** is a side view of a dielectric mounting support for a cross-dipole radiator according to further embodiments of the present invention.

[0017] **FIG. 11** is a perspective view of a three-dimensional cross-dipole radiator according to embodiments of the present invention.

[0018] **FIG. 12** is an enlarged perspective view of one of the high-band radiating element assemblies of the base station antenna of **FIGS. 1-4**.

[0019] **FIG. 13** is a flow chart illustrating a method of fabricating a radiating element according to embodiments of the present invention.

DETAILED DESCRIPTION

[0020] Embodiments of the present invention relate generally to radiating elements for base station antennas that include dipole radiators that are formed of pieces of sheet metal that are adhered to a dielectric mounting support. The pieces of sheet metal may form one or more dipoles. The sheet metal dipoles may be mounted onto the dielectric mounting support using an adhesive. The dielectric mounting support may physically support the sheet metal dipoles to reduce the tendency of the thin dipoles to move and/or bend during use. Herein, such dipole radiators may be referred to as "sheet metal-on-dielectric radiators."

[0021] As noted above, base station antennas having printed circuit board-based dipole radiators are known in the art. Printed circuit boards, however, may be relatively expensive. Aluminum and/or copper sheet metal may be relatively inexpensive and can easily be stamped to form desired planar shapes. Consequently, the dipole radiators

according to embodiments of the present invention may be cheaper than printed circuit board-based dipole radiators. Moreover, one potential difficulty with printed circuit board based-dipole radiators is that the thickness of the metal layers on standard printed circuit boards may be less than desirable to ensure low signal transmission loss and good impedance matching with the feeding RF transmission lines. While printed circuit boards can be fabricated to have thicker metal layers, these non-standard printed circuit boards may cost significantly more. Since state-of-the art multi-band base station antenna may have a large number of radiating elements (e.g., 25-40), the use of such specialized printed circuit boards can have measurable impact on the price of a base station antenna. The sheet metal-on-dielectric dipole radiators according to embodiments of the present invention may be formed to have any desired thickness, and hence may exhibit improved impedance matching and/or reduced signal transmission losses as compared to low-cost printed circuit board based dipole radiators.

[0022] The radiating elements having sheet metal-on-dielectric dipole radiators according to embodiments of the present invention may also exhibit improved passive intermodulation ("PIM") distortion performance as compared to printed circuit board based dipole radiators. In particular, metal layers on printed circuit boards generally have a relatively high degree of surface roughness, which may help reduce the possibility that layers of the printed circuit board delaminate. This surface roughness may, however, be a source for PIM distortion. Moreover, while printed circuit boards having reduced levels of surface roughness may be obtained, these printed circuit boards cost more and still have some degree of surface roughness. As a result, radiating elements formed using printed circuit board based dipole radiators may tend to exhibit higher levels of PIM distortion. Sheet metal may be readily obtained that has very low levels of surface roughness, and can also be readily and inexpensively polished to further reduce surface roughness. Accordingly, the radiating elements according to embodiments of the present invention may be cheaper than conventional radiating elements that use printed circuit board based dipole radiators and may also provide enhanced performance.

[0023] In some embodiments, the sheet metal-on-dielectric dipole radiators according to embodiments of the present invention may be formed as non-planar elements. This may allow the dipoles to have a desired electrical length while reducing the "footprint" of each dipole (i.e., the size of the dipole when viewed from the front of the antenna). By reducing the footprint, the physical spacing between the radiating elements of adjacent linear arrays may be increased, which may reduce the impact that adjacent radiating elements have on

their respective radiation patterns. In other embodiments, the dielectric mounting substrate may include an integrated dipole support structure to reduce manufacturing costs and improve the physical stability of the radiating element.

[0024] Embodiments of the present invention will now be described in further detail with reference to the attached figures.

[0025] FIGS. 1-4 illustrate a base station antenna 100 that includes radiating elements having sheet metal-on-dielectric dipole radiators according to certain embodiments of the present invention. FIG. 1 is a front perspective view of the base station antenna 100, while FIGS. 2 and 3 are a perspective view and a front view, respectively, of the antenna 100 with the radome thereof removed to illustrate the inner components of the antenna. FIG. 4 is an enlarged partial perspective view of the base station antenna 100 with the radome thereof removed.

[0026] As shown in FIGS. 1-4, the base station antenna 100 is an elongated structure that extends along a longitudinal axis L. The antenna 100 is typically mounted in a vertical orientation (i.e., the longitudinal axis L may be generally perpendicular to a plane defined by the horizon when the antenna 100 is mounted for use). In the description that follows, the antenna 100 and sub-components thereof will be described using terms that assume that the antenna 100 is mounted for use on a tower with the longitudinal axis L of the antenna 100 extending along a generally vertical axis and the front surface of the antenna 100 mounted opposite the tower pointing toward the coverage area for the antenna 100.

[0027] Referring to FIG. 1, the base station antenna 100 may have a tubular shape with a generally rectangular cross-section. The antenna 100 includes a radome 110 and a top end cap 120. One or more mounting brackets 150 are provided on the rear side of the radome 110 which may be used to mount the antenna 100 onto an antenna mount (not shown) on, for example, an antenna tower. The antenna 100 also includes a bottom end cap 130 which includes a plurality of connectors 140 mounted therein.

[0028] As shown in FIGS. 2-3, the base station antenna 100 includes an antenna assembly 200 that may be slidably inserted into the radome 110. The antenna assembly 200 includes a ground plane structure 210 that has sidewalls 212 and a reflector 214. The reflector 214 may comprise a metallic surface that serves as a reflector and ground plane for the radiating elements of the antenna 100. A plurality of radiating elements 300, 400 are mounted to extend forwardly from the reflector 214. The radiating elements include low-band radiating elements 300 and high-band radiating elements 400. As shown best in FIG. 3, the low-band radiating elements 300 are mounted in two vertical columns to form two

vertically-disposed linear arrays **220-1**, **220-2** of low-band radiating elements **300**. The high-band radiating elements **400** may also be mounted in two vertical columns to form two vertically-disposed linear arrays **230-1**, **230-2** of high-band radiating elements **400**. The low-band radiating elements **300** may be configured to transmit and receive signals in a first frequency band such as, for example, the 694-960 MHz frequency range or a portion thereof. The high-band radiating elements **400** may be configured to transmit and receive signals in a second frequency band such as, for example, the 1695-2690 MHz frequency range or a portion thereof.

[0029] **FIG. 4** is an enlarged partial perspective view of the base station antenna **100** with the radome **110** removed. As can be seen in **FIG. 4**, each low-band linear array **220** may include a plurality of low-band radiating element feed assemblies **250**, each of which includes two low-band radiating elements **300**. Each high-band linear array **230** may include a plurality of high-band radiating element feed assemblies **260**, each of which includes one to three high-band radiating elements **400**. The low-band and high-band radiating elements **300**, **400** are located in very close proximity to each other. The low-band radiating elements **300** and the high-band radiating elements are mounted to extend forwardly from the ground plane structure **210**, with the low-band radiating elements **300** extending farther forwardly than the high-band radiating elements **400**.

[0030] **FIGS. 5-7** are a perspective view, a front view and a side view, respectively, of one of the low-band radiating element assemblies **250** included in the base station antenna **100**. The low-band feed board assembly **250** includes a printed circuit board **252** that has first and second low-band radiating elements **300-1**, **300-2** extending forwardly from either end thereof. The printed circuit board **252** includes RF transmission line feeds **254** that provide RF signals to, and receive RF signals from, the respective low-band radiating elements **300-1**, **300-2**. Each low-band radiating element **300** includes a feed stalk **310** and a cross-dipole radiator **320** that is mounted on the forward end of the feed stalk **310**.

[0031] Each feed stalk **310** may comprise a pair of printed circuit boards **312-1**, **312-2** that have RF transmission lines **314** formed thereon. These RF transmission lines **314** carry RF signals between the printed circuit board **252** and the cross-dipole radiators **320**. A first of the printed circuit boards **312-1** may include a lower vertical slit and the second of the printed circuit boards **312-2** includes an upper vertical slit. These vertical slits allow the printed circuit boards **312** to be assembled together to form a vertically-extending column that has generally x-shaped cross-section. Lower portions of each printed circuit board **312** may include plated projections **316**. These plated projections **316** are inserted through slits in

the printed circuit board **252**. The plated projections **316** of printed circuit board **312** may be soldered to plated portions on printed circuit board **252** to electrically connect the printed circuit boards **312** to the printed circuit board **252**. The RF transmission lines **314** on the respective feed stalks **310** may feed the RF signals to the cross-dipole radiators **320**. Dipole supports **318** may also be provided to hold the cross-dipole radiators **320** in their proper positions.

[0032] **FIGS. 8A-9B** illustrate the cross-dipole radiator **320** of one of the radiating elements **300** of low-band feed assembly **300** in greater detail. **FIGS. 8A** and **8B** are a perspective view and an exploded perspective view, respectively, of the cross-dipole radiator **320**. **FIGS. 9A-9B** are a front view and a rear view of a dielectric mounting substrate **340** of the cross-dipole radiator **320** of **FIGS. 8A-8B**.

[0033] The cross-dipole radiator **320** includes first and second metal dipoles **330-1**, **320-2**. The first metal dipole **330-1** includes first and second dipole arms **332-1**, **332-2**, and the second metal dipole **330-2** includes third and fourth dipole arms **332-3**, **332-4**. All four dipole arms **332** are mounted on the dielectric mounting substrate **340**. Each metal dipole **330** may, for example, have two dipole arms **332** that are between 0.2 to 0.35 of an operating wavelength in length, where the "operating wavelength" refers to the wavelength corresponding to the center frequency of the operating frequency band of the radiating element **300**. For example, if the low-band radiating elements **300** are designed as wideband radiating elements that are used to transmit and receive signals across the full 694-960 MHz frequency band, then the center frequency of the operating frequency band would be 827 MHz and the corresponding operating wavelength would be 36.25 cm.

[0034] As shown in **FIG. 8A**, the first metal dipole **330-1** extends along a first axis **322-1** and the second metal dipole **330-2** extends along a second axis **322-2** that is generally perpendicular to the first axis **322-1**. The dipole arms **332-1** and **332-2** that form the first metal dipole **330-1** are center-fed by a common RF transmission line **314** and together directly radiate at a +45 degree polarization. Dipole arms **332-3** and **332-4** of the second metal dipole **330-2** are likewise center fed by a common RF transmission line **314** and together directly radiate at a -45 degree polarization. The dipole arms **332** may be soldered to the feed stalk **310** so that the first and second metal dipoles **330-1**, **330-2** are fed via direct ohmic connections between the transmission lines **314** and the dipole arms **332**. The dipole supports **318** may reduce the forces applied to the solder joints that electrically connect the transmission lines **314** to the dipole arms **332**. The dipole arms **332** may be mounted approximately $\frac{3}{16}$ to $\frac{1}{4}$ of an operating wavelength in front of the reflector **214** by the feed

stalks **310**. The reflector **214** may be immediately behind the feed board printed circuit board **252**.

[0035] Each dipole arm **332** includes first and second spaced-apart conductive segments **334-1**, **334-2** that together form a generally oval shape. In the depicted embodiment, all four dipole arms **332** lie in a common plane that is generally parallel to a plane defined by the underlying reflector **214**. Each feed stalk **310** may extend in a direction that is generally perpendicular to the plane defined by the dipole arms **332**. Each conductive segment **334-1**, **334-2** may comprise a metal pattern that has a plurality of widened segments **336** and at least one narrowed trace section **338**. The narrowed trace sections **338** may be implemented as non-linear conductive traces that follow a meandered path to increase the path length thereof. The first conductive segment **334-1** may form half of the generally oval shape and the second conductive segment **334-2** may form the other half of the generally oval shape. The dipole arms **330** may have shapes other than a generally oval shape, such as, for example, an elongated generally rectangular shape.

[0036] As shown in **FIG. 8A**, each widened section **336** of the conductive segments **334-1**, **334-2** may have a respective width W_1 . The narrowed trace sections **338** may similarly have a respective width W_2 . The widths W_1 and W_2 are measured in a direction that is generally perpendicular to the direction of instantaneous current flow along the respective sections **336**, **338**. The respective widths W_1 and W_2 of each widened section **336** and each narrowed trace section **338** need not be constant, and hence in some instances reference will be made to the average widths of the widened sections **336** and the narrowed trace sections **338**. The average width of each widened section **336** may be, for example, at least twice the average width of each narrowed trace section **338** in some embodiments. In other embodiments, the average width of each widened section **336** may be at least three, four or five times the average width of each narrowed trace section **338**.

[0037] When the high-band radiating elements **400** transmit and receive signals, the high-band RF signals may tend to induce currents on the dipole arms **332** of the low-band radiating elements **300**. This can particularly be true when the low-band and high-band radiating elements **300**, **400** are designed to operate in frequency bands having center frequencies that are separated by about a factor of two, as a low-band dipole arm **332** having a length that is about a quarter wavelength of the low-band operating frequency will, in that case, have a length of approximately a half wavelength of the high-band operating frequency. The greater the extent that high-band currents are induced on the low-band dipole arms **332**,

the greater the impact on the characteristics of the radiation pattern of the linear arrays **230** of high-band radiating elements **400**.

[0038] The narrowed trace sections **338** may act as high impedance sections that interrupt currents in the high-band frequency range that could otherwise be induced on the low-band dipole arms **332**. The narrowed trace sections **338** may create this high impedance for high-band currents without significantly impacting the flow of the low-band currents on the dipole arms **332**. As such, the narrowed trace sections **338** may reduce induced high-band currents on the low-band radiating elements **300** and consequent disturbance to the antenna pattern of the high-band linear arrays **230**. In some embodiments, the narrowed trace sections **338** may make the low-band radiating elements **300** almost invisible to the high-band radiating elements **400**, and thus the low-band radiating elements **300** may not distort the high-band antenna patterns.

[0039] As can further be seen in **FIGS. 8A** and **8B**, the distal ends of the conductive segments **334-1**, **334-2** may be electrically connected to each other so that the conductive segments **334-1**, **334-2** form a closed loop structure. In the depicted embodiment, some of the conductive segments **334-1**, **334-2** are electrically connected to each other by a narrowed trace section **338**, while in other embodiments the widened sections **336** at the distal ends of conductive segments **334-1**, **334-2** may merge together. In still other embodiments, different electrical connections may be used, or the distal ends of the conductive segments **334-1**, **334-2** may not be physically connected to each other. As can also be seen, the interior of the loop defined by the conductive segments **334-1**, **334-2** (which may or may not be a closed loop) may be generally free of conductive material. Additionally, at least some of the dielectric mounting substrate **340** on which the conductive segments **334-1**, **334-2** are mounted may be omitted in the interior of the loop. Some of the dielectric of mounting substrate **340** may be left in the interior of the loops to provide structural support and/or to provide locations for attaching the dipole support structure **318** to each dipole arm **332**.

[0040] By forming each dipole arm **332** as first and second spaced-apart conductive segments **334-1**, **334-2**, the currents that flow on the dipole arm **332** may be forced along two relatively narrow paths that are spaced apart from each other. This approach may provide better control over the radiation pattern. Additionally, by using the loop structure, the overall length of the dipole arms **332** may be reduced, allowing greater separation between each dipole arm **332** and other radiating elements **300**, **400**.

[0041] In some embodiments, the first and second metal dipoles **330-1**, **330-2** may have "unbalanced" dipole arms **332** that have different shapes or sizes. The use of

unbalanced dipole arms **332** may help correct for unbalanced current flow that may otherwise occur in radiating elements **300** that are located along the outer edges of a reflector **214**. Such unbalanced current flow may occur because the inner dipole arms **332** on radiating elements **300** that are positioned close to the side edges of the reflector may "see" more of the ground plane **214** than the outer dipole arms **332**. This may cause an imbalance in current flow, which may negatively affect the patterns of the low-band antenna beams. This imbalance may be reduced, for example, by including more metal along the distal edges of the outer dipole arms **332** that are adjacent the edge of the ground plane **214**.

[0042] In some embodiments, capacitors may be formed between adjacent dipole arms **332** of different metal dipoles **330**. For example, a first capacitor may be formed between dipole arms **332-1** and **332-3** and a second capacitor may be formed between dipole arms **332-2** and **332-4**. These capacitors may be used to tune (improve) the return loss performance and/or antenna pattern for the low-band metal dipoles **330-1**, **330-2**. In some embodiments, the capacitors may be formed on the feed stalks **310**.

[0043] As discussed above, pursuant to embodiments of the present invention, the dipole radiators **320** may be implemented by forming sheet metal in the desired shape for each dipole arm **332** and then adhering the dipole arms **332** to a dielectric mounting substrate **340**. FIGS. **8B** and **9A-9B** illustrate this implementation in greater detail. The dipole arms **332** may be formed, for example, by stamping, laser cutting, wire electrical discharge machining (EDM) cutting, machining or other high volume production processes.

[0044] Turning first to FIG. **8B**, an exploded perspective view of the cross-dipole radiator **320** is illustrated. As shown in FIG. **8B**, the four dipole arms **332** may be separately stamped from a sheet of metal such as a thin sheet of copper or aluminum. The dipole arms **332** may be manufactured cheaply and easily by this technique, and the metal that is cut away during the stamping operation may be recycled to reduce costs. The sheet metal may have a desired thickness for the thickness of the dipole arms **332**. This thickness may be selected based on a variety of considerations, including cost, weight, the impedance match of the dipole arms **332** to respective transmission lines **314** on the feed stalk **310** and/or signal loss for currents flowing along the dipole arms **332**. Typically, cost and weight considerations may favor reduced thicknesses for the dipole arms **332**, while impedance match and signal loss considerations tend to favor increased thickness. In some embodiments, the dipole arms **332** may have a thickness that is between five and forty-five times the thickness of the metal layers on conventional printed circuit boards. For example, the sheet metal may have a

thickness between 200 and 1800 microns in some embodiments. These increased thicknesses for the metal dipole arms **332** may provide improved RF performance.

[0045] The sheet metal that is used to form the dipole arms **332** may have very smooth major surfaces, either as manufactured or because a polishing or another smoothing operation is performed thereon. It is believed that roughness in the metal surface may be a source of PIM distortion. As known to those of skill in the art, PIM distortion is a form of electrical interference that may occur when two or more RF signals encounter non-linear electrical junctions or materials along an RF transmission path. Rough metal surfaces along an RF transmission path are one potential source for PIM distortion, particularly when such rough surfaces are in high current density regions of the RF transmission path. The nonlinearities that arise may act like a mixer causing new RF signals to be generated at mathematical combinations of the original RF signals. If the newly generated RF signals fall within the bandwidth of the radio receiver, the noise level experienced by the receiver is effectively increased. When the noise level is increased, it may be necessary to reduce the data rate and/or the quality of service. By using sheet metal having very smooth surfaces to form the dipole arms **332**, the risk of PIM distortion arising in the dipole arms **332** may be significantly reduced.

[0046] As is further shown in **FIG. 8B**, the metal dipole arms **332** may be attached to the dielectric substrate **340** using an adhesive **350**. The adhesive **350** may be coated onto one or both of the metal dipole arms **332** or the dielectric mounting substrate **340**. In some embodiments, the adhesive **350** may be double liner adhesive transfer tape. It will also be appreciated that the metal dipole arms **332** may be attached to the dielectric mounting substrate **340** via other attachment mechanisms. For example, in other embodiments, the metal dipole arms **332** may be attached to the dielectric mounting substrate **340** by overmolding the dielectric mounting substrate **340** onto the metal dipole arms **332**. In still other embodiments, the metal dipole arms **332** may be attached to the dielectric mounting substrate **340** via ultrasonic welding. As another example, the metal dipole arms **332** may be attached to the dielectric mounting substrate **340** using a heat stake system that is used to partially melt and deform the dielectric substrate to join the metal dipole arms **332** thereto. The metal dipole arms **332** may also be attached to the dielectric mounting substrate **340** as a sheet metal laminate. In still other embodiments, mechanical fasteners such as screws, rivets or the like may be used. Attachment mechanisms other than the example mechanisms discussed above may be used. Thus, it will be appreciated that the metal dipole arms **332** may be

attached to the dielectric mounting substrate **340** in a wide variety of different attachment mechanisms.

[0047] Referring to **FIGS. 8A** and **9A-9B**, the dielectric mounting substrate **340** may be formed of plastic or another relatively rigid, inexpensive, dielectric material. The dielectric mounting substrate **340** may be a generally planar sheet of material in some embodiments having a front surface **341** and a rear surface **342**. Referring to **FIGS. 8A-8B** and **9A**, a plurality of guides **343** in the form of raised nubs may be provided on the front surface **341**. As can be seen best in **FIG. 8A**, the guides **343** may facilitate maintaining the dipole arms **332** in their proper positions on the dielectric mounting substrate **340**. Guides **343** may be provided in center portions of the narrow meandered trace sections **338**, between and/or along edges of the widened sections **336** and/or between adjacent dipole arms **332**.

[0048] The dielectric mounting substrate **340** may include four central openings **344** that receive respective ones of extensions **313** (see **FIG. 7**) on the forward ends of the printed circuit boards **312-1**, **312-2**. A respective RF transmission line **314** may extend onto each extension **313**, and solder joints may be formed between the respective extensions **313** and the cross-dipole radiator **320** that physically connect the cross-dipole radiator **320** to the feed stalk **310** while electrically connecting a transmission line **314** to each respective dipole arm **332**. One or more openings **345** may be provided in an interior portion of the dielectric mounting substrate **340** where the dielectric material is removed/omitted. In some embodiments, these openings **345** may be within the interior of the loops defined by the respective dipole arms **332**. Generally speaking, the dielectric material may negatively impact the RF performance of the low-band radiating elements **300**. The greater the amount of dielectric material used also tends to increase the impact that the low-band radiating element **300** has on the radiation patterns of adjacent high-band radiating elements **400**. Accordingly, the amount of dielectric material may be kept as low as possible in some embodiments. Removing dielectric material in the interior of the loops formed in the respective dipole arms **332** may provide one convenient way of reducing the amount of dielectric material in the dielectric mounting support **340**.

[0049] Referring to **FIG. 9B**, the rear surface **342** of dielectric mounting substrate **340** may include a rearwardly-extending lip **346** that extends part or all of the way around the periphery of the rear surface **342**. The lip **346** may provide increased structural integrity, allowing the thickness of the remainder of the dielectric mounting substrate **340** to be reduced. Likewise, support ribs **347** may be provided on the rear surface **342** of the dielectric

mounting substrate **340** to provide additional structural rigidity. The ribs **344** may be primarily provided underneath the dipole arms **332**.

[0050] The dielectric mounting substrate **340** may be formed by any appropriate process including, for example, injection molding, other forms of molding, cutting, stamping or the like. Injection molding may be preferred in embodiments that include lips **346** and/or ribs **347**. The dielectric mounting substrate **340** may typically comprise a single piece of dielectric material that all four dipole arms **332** are adhered to, although multi-piece dielectric mounting substrates may be used in some embodiments.

[0051] While **FIGS. 8A-9B** illustrate a cross-dipole radiator **320** that has the dipole arms **332** formed on the front surface **341** of the dielectric mounting support **340**, embodiments of the present invention are not limited thereto. For example, in other embodiments, the dipole arms **332** may be adhered to the rear surface **342** of the dielectric mounting substrate **340** via the adhesive **350**.

[0052] Pursuant to further embodiments of the present invention, radiating elements are provided which include both a dielectric mounting substrate and a dipole support that are integrated as a single monolithic dielectric mounting substrate and dipole support structure. **FIG. 10** illustrates one example implementation of a radiating element **500** that includes such a monolithic dielectric mounting substrate and dipole support structure **540**. The monolithic dielectric mounting substrate and dipole support structure **540** may replace the dielectric mounting substrate **340** and dipole support **318** of the radiating element **300** described above. The dielectric mounting substrate and dipole support structure **540** can be formed, for example, by injection molding. As described above with reference to **FIGS. 8A-9B**, stamped metal dipole arms **332** (not visible in **FIG. 10**) may be formed and adhered to the front surface **541** of the dielectric mounting substrate and dipole support structure **540**. Use of a monolithic dielectric mounting substrate and dipole support structure **540** may be advantageous as it reduces assembly time and provides a more stable and stronger connection between the support structure and the cross-dipole radiator **520**. This may reduce vibrational movement of the cross-dipole radiator **520** and/or allow for a less substantial dipole support. Aside from replacing the dielectric mounting substrate **340** and dipole support **318** of radiating element **300** with a monolithic dielectric mounting substrate and dipole support structure **540**, radiating element **500** may be identical to radiating element **300** and hence further description thereof will be omitted.

[0053] Pursuant to still further embodiments of the present invention, radiating elements are provided that have three-dimensional cross-dipole radiators **620**. Such three-

dimensional cross-dipole radiators **620** may readily be formed by bending the stamped metal dipole arms **332** (to form dipole arms **632**) and by forming three-dimensional dielectric mounting substrates **640** via, for example, injection molding. The use of such three-dimensional cross-dipole radiators **620** may be advantageous for reducing the overall footprint of the cross-dipole radiator **620** when viewed from the front of the base station antenna, which may increase the distance between adjacent radiating elements (thereby improving isolation), allow for a reduction in the size of the base station antenna, and/or provide room for additional radiating elements.

[0054] FIG. 11 is a side front perspective view of a cross-dipole radiator **620** that has such a three-dimensional shape. As shown in FIG. 11, the cross-dipole radiator **620** may be similar to the cross-dipole radiator **320** that is discussed above, and may include four dipole arms **632-1** through **632-4** that are adhered to a dielectric mounting substrate **640**. The dipole arms **632** may be identical to the dipole arms **332** except that the dipole arms **632** are bent to have a plurality of wave-like undulations **638**. Likewise, the dielectric mounting substrate **640** may be identical to the dielectric substrate **340** except that the dielectric mounting substrate **640** may include a plurality of wave-like undulations **648**. The undulations **638** may be spaced apart from each other along the longitudinal axis of the respective dipole arms. Consequently, the undulations **638** in dipole arms **632-1** and **632-2** may be spaced apart from each other in a first direction and the undulations **638** in dipole arms **632-3** and **632-4** may be spaced apart from each other in a second direction that is different than the first direction. The undulations **638** may conform to the undulations **648** so that the dipole arms **632** may be readily adhered to the dielectric mounting substrate **640** and may be a substantially constant distance from the dielectric mounting substrate **640**.

[0055] Forming the dipole arms **632** and the dielectric mounting substrate **640** to include the undulations **638**, **648** acts to reduce the physical "footprint" of the cross-dipole radiator **620**. Herein, the footprint of a dipole (or cross-dipole) radiator refers to the area of the reflector that the dipole radiator "covers" when the dipole radiator is viewed from the front along a central axis of the feed stalk that the dipole radiator is mounted on. Typically, the length of each metal dipole (and hence the lengths of the dipole arms that may form the metal dipole) is set based on desired RF radiating characteristics for the radiating element. By bending the dipole arms **632** of cross-dipole radiator **620** to include one or more undulations **638**, the footprint of cross-dipole radiator **620** may be reduced without effecting the length of the metal dipoles **630** thereof. Such three-dimensional cross-dipole radiators cannot readily be formed using printed circuit board technology, since conventional printed

circuit board are planar structures. Moreover, while flexible printed circuit boards are known in the art, the metal layers on such flexible printed circuit boards typically are very thin and generally unsuitable for use as a dipole radiator of a base station antenna.

[0056] In the embodiment of **FIG. 11**, the undulations **638, 648** are curved undulations having a generally sinusoidal shape. It will be appreciated that the shape, frequency and magnitude (i.e., peak to trough distance) of the undulations **638, 648** may be varied. It will also be appreciated that only portions of each dipole arm **632** may include undulations **638** in some embodiments.

[0057] **FIG. 12** is a front perspective view of one of the high-band feed board assemblies **260** that are included in the base station antenna **100**. As shown in **FIG. 12**, the high-band feed board assembly **260** includes a printed circuit board **262** that has three high band radiating elements **400-1, 400-2, 400-3** extending forwardly therefrom. The printed circuit board **262** includes RF transmission line feeds **264** that provide RF signals to, and receive RF signals from, the respective high-band radiating elements **400-1** through **400-3**. Each high-band radiating element **400** includes a pair of feed stalks **410** that have a cross-dipole radiator **420** mounted thereon.

[0058] The feed stalks **410** may each comprise a pair of printed circuit boards that have RF transmission line feeds formed thereon. The feed stalks **410** may be assembled together to form a vertically-extending column that has generally x-shaped cross-sections. Each cross-dipole radiator **420** may also be implemented as a sheet metal-on-dielectric dipole radiator. In particular, cross-dipole radiator **420** may include four dipole arms **432** that together form first and second cross-polarized center fed metal dipoles **430-1, 430-2**. The dipole arms **432** may be adhered to an underlying dielectric mounting substrate **440**. As the cross-dipole radiator **420** may be identical to the cross-dipole radiator **320** discussed above except that the size thereof and the shape of the dipole arms **432** are modified for operation at the higher frequency band, further description of the cross-dipole radiators **420** will be omitted.

[0059] As shown in **FIG. 13**, pursuant to embodiments of the present invention, methods of fabricating a radiating element for a base station antenna are provided. Pursuant to these methods, first and second metal dipoles may be stamped from one or more sheets of sheet metal (block **700**). In some cases, each metal dipole may comprise two dipole arms that are separately stamped, while in other embodiments, each metal dipole may be a monolithic structure that is formed in a single stamping operation. A dielectric mounting substrate is also formed using, for example, injection molding, another molding technique, or by cutting

or stamping the dielectric mounting substrate from dielectric sheet material (block 710). The first and second metal dipoles may then be adhered to the dielectric mounting substrate using an adhesive to form a cross-dipole radiator (block 720). The cross-dipole radiator may then be mounted on a feed stalk (block 730).

[0060] While embodiments of the present invention have primarily been discussed above with respect to cross-dipole radiators, it will be appreciated that all of the above-described aspects of the present invention may be applied to single-polarization radiating elements that have a single dipole radiator as opposed to cross-polarized dipole radiators. It will likewise be appreciated that the techniques described herein may be used with any type of dual-polarized radiating element and not just with slant $-45^{\circ}/+45^{\circ}$ dipole radiating elements.

[0061] The radiating elements according to embodiments of the present invention may provide a number of advantages over conventional radiating elements. As discussed above, the dipole radiators according to embodiments of the present invention may be significantly cheaper to manufacture as compared to printed circuit board dipole radiators. Additionally, because the thickness of the metal dipole arms may be, for example, five to forty-five times the thickness of low-cost printed circuit board dipole radiators, the dipole radiators according to embodiments of the present invention may exhibit reduced signal transmission loss and may have better impedance match with the RF transmission lines on the feed stalks, resulting in improved return loss performance.

[0062] Additionally, since the metal dipoles may be very smooth (i.e., almost no surface roughness), the dipole radiators according to embodiments of the present invention may exhibit improved PIM performance as compared to printed circuit board based dipole radiators, and the relatively large batch-to-batch variation that is present with printed circuit board based dipole radiators may be significantly reduced, providing more consistent RF performance. Moreover, since the dielectric mounting substrate may be injection molded to include desired cutouts, the fabrication step of cutting openings into printed circuit board based dipole radiators may be eliminated, further reducing manufacturing costs. Additionally, in some embodiments, the dipole radiators may include undulations that reduce the footprint thereof, and/or may include integrated dipole supports that provide increased stability.

[0063] Embodiments of the present invention have been described above with reference to the accompanying drawings, in which embodiments of the invention are shown. This invention may, however, be embodied in many different forms and should not be

construed as limited to the embodiments set forth herein. Rather, these embodiments are provided so that this disclosure will be thorough and complete, and will fully convey the scope of the invention to those skilled in the art. Like numbers refer to like elements throughout.

[0064] It will be understood that, although the terms first, second, etc. may be used herein to describe various elements, these elements should not be limited by these terms. These terms are only used to distinguish one element from another. For example, a first element could be termed a second element, and, similarly, a second element could be termed a first element, without departing from the scope of the present invention. As used herein, the term "and/or" includes any and all combinations of one or more of the associated listed items.

[0065] It will be understood that when an element is referred to as being "on" another element, it can be directly on the other element or intervening elements may also be present. In contrast, when an element is referred to as being "directly on" another element, there are no intervening elements present. It will also be understood that when an element is referred to as being "connected" or "coupled" to another element, it can be directly connected or coupled to the other element or intervening elements may be present. In contrast, when an element is referred to as being "directly connected" or "directly coupled" to another element, there are no intervening elements present. Other words used to describe the relationship between elements should be interpreted in a like fashion (*i.e.*, "between" versus "directly between", "adjacent" versus "directly adjacent", etc.).

[0066] Relative terms such as "below" or "above" or "upper" or "lower" or "horizontal" or "vertical" may be used herein to describe a relationship of one element, layer or region to another element, layer or region as illustrated in the figures. It will be understood that these terms are intended to encompass different orientations of the device in addition to the orientation depicted in the figures.

[0067] The terminology used herein is for the purpose of describing particular embodiments only and is not intended to be limiting of the invention. As used herein, the singular forms "a", "an" and "the" are intended to include the plural forms as well, unless the context clearly indicates otherwise. It will be further understood that the terms "comprises" "comprising," "includes" and/or "including" when used herein, specify the presence of stated features, operations, elements, and/or components, but do not preclude the presence or addition of one or more other features, operations, elements, components, and/or groups thereof.

[0068] Aspects and elements of all of the embodiments disclosed above can be combined in any way and/or combination with aspects or elements of other embodiments to provide a plurality of additional embodiments.

That Which is Claimed is:

1. A radiating element for a base station antenna, comprising:
a feed stalk;
a cross-dipole radiator mounted on the feed stalk, the cross-dipole radiator including:
a dielectric mounting substrate;
a first metal dipole that extends along a first axis on the dielectric mounting substrate, the first metal dipole including a first dipole arm and a second dipole arm;
a second metal dipole that extends along a second axis on the dielectric mounting substrate, the second metal dipole including a third dipole arm and a fourth dipole arm, the second axis being generally perpendicular to the first axis; and
an adhesive that attaches the first and second metal dipoles to the dielectric mounting substrate.
2. The radiating element of Claim 1, wherein the dielectric mounting substrate further includes a plurality of guides.
3. The radiating element of Claim 2, wherein the dielectric mounting substrate includes a plurality of ribs on a first major surface thereof.
4. The radiating element of Claim 3, wherein the guides are configured to mount the first through fourth dipole arms in respective pre-selected locations on the dielectric mounting substrate, and wherein the guides on a second major surface of the dielectric mounting substrate that is opposite the first major surface.
5. The radiating element of any of Claims 1-4, wherein each of the first through fourth dipole arms are non-planar dipole arms.
6. The radiating element of Claim 5, wherein each of the first through fourth dipole arms includes undulations.
7. The radiating element of Claim 6, wherein the dielectric mounting substrate includes undulations that conform to the respective undulations of the first through fourth dipole arms.

8. The radiating element of any of Claims 1-7, wherein the dielectric mounting substrate comprises a monolithic structure that has a generally planar dipole support plate and a plurality of support arms that extend rearwardly from the dipole support plate.

9. The radiating element of any of Claims 1-8, wherein a thickness of the first metal dipole is between 200 and 1800 microns.

10. The radiating element of any of Claims 1-4, wherein each of the first through fourth dipole arms has first and second spaced-apart conductive segments that together form a generally oval shape.

11. The radiating element of Claim 10, wherein distal ends of the first and second conductive segments of the first dipole arm are electrically connected to each other so that the first dipole arm has a closed loop structure.

12. The radiating element of Claim 10, wherein each of the first and second conductive segments of the first through fourth dipole arms includes a first widened section that has a first average width, a second widened section that has a second average width and a narrowed section that has a third average width, the narrowed section being between the first widened section and the second widened section, wherein the third average width is less than half the first average width and less than half the second average width.

13. The radiating element of Claim 12, wherein the narrowed section comprises a meandered conductive trace.

14. The radiating element of Claim 12, wherein the narrowed section creates a high impedance for currents that are at a frequency that is approximately twice the highest frequency in the operating frequency range of the radiating element.

15. The radiating element of any of Claims 1-15, wherein the first metal dipole directly radiates radio frequency ("RF") signals at a +45° polarization and the second metal dipole directly radiates RF signals at a -45° polarization.

16. The radiating element of any of Claims 1-15, wherein the adhesive comprises an adhesive layer that is between the dielectric mounting substrate and the first and second metal dipoles.

17. The radiating element of any of Claims 1-15, wherein the adhesive comprises a double-sided adhesive tape.

18. A radiating element for a base station antenna, comprising:
a feed stalk;

a dipole radiator mounted on the feed stalk, the dipole radiator including:

a dielectric mounting substrate that includes a plurality of first undulations;

and

a metal dipole that includes a plurality of second undulations that extends along the dielectric mounting substrate at a substantially constant distance from a surface of the dielectric mounting substrate.

19. The radiating element of Claim 18, further comprising an attachment mechanism that attaches the metal dipole to the dielectric mounting substrate.

20. The radiating element of Claim 19, wherein the metal dipole comprises a first metal dipole and the dipole radiator comprises a cross-dipole radiator that further includes a second metal dipole that extends along the dielectric mounting substrate at a substantially constant distance from a surface of the dielectric mounting substrate, wherein the first metal dipole extends along a first axis and the second metal dipole extends along a second axis that is substantially perpendicular to the first axis.

21. The radiating element of Claim 20, wherein the first metal dipole includes a first dipole arm and a second dipole arm, and the second metal dipole includes a third dipole arm and a fourth dipole arm.

22. The radiating element of any of Claims 18-21, wherein a first major surface of the dielectric mounting substrate includes a plurality of ribs, and a second major surface of the dielectric mounting substrate that is opposite the first major surface includes a plurality of guides.

23. The radiating element of Claim 22, wherein the guides are configured to mount the metal dipole in a pre-selected location on the dielectric mounting substrate.

24. The radiating element of any of Claims 18-24, wherein a thickness of the metal dipole is between 200 and 1800 microns.

25. The radiating element of Claim 21, wherein each of the first through fourth dipole arms has first and second spaced-apart conductive segments that together form a generally oval shape.

26. The radiating element of Claim 25, wherein distal ends of the first and second conductive segments of the first dipole arm are electrically connected to each other so that the first dipole arm has a closed loop structure.

27. The radiating element of Claim 25, wherein each of the first and second conductive segments of the first through fourth dipole arms includes a first widened section that has a first average width, a second widened section that has a second average width and a narrowed section that has a third average width, the narrowed section being between the first widened section and the second widened section, wherein the third average width is less than half the first average width and less than half the second average width.

28. The radiating element of Claim 27, wherein the narrowed section comprises a meandered conductive trace.

29. The radiating element of Claim 27, wherein the narrowed section creates a high impedance for currents that are at a frequency that is approximately twice the highest frequency in the operating frequency range of the radiating element.

30. The radiating element of any of Claims 18-29, wherein the first metal dipole directly radiates radio frequency ("RF") signals at a +45° polarization and the second metal dipole directly radiates RF signals at a -45° polarization.

31. The radiating element of any of Claims 18-29, wherein the attachment mechanism comprises an adhesive layer that is between the dielectric mounting substrate and the metal dipole.

32. The radiating element of any of Claims 18-29, wherein the attachment mechanism comprises an over-molded portion of the dielectric mounting substrate that holds and the metal dipole in place on a surface of the dielectric mounting substrate.

33. The radiating element of any of Claims 18-29, wherein the attachment mechanism comprises a double-sided adhesive tape.

34. The radiating element of any of Claims 18-29, wherein the attachment mechanism comprises one or more mechanical fasteners.

35. The radiating element of any of Claims 18-29, wherein the attachment mechanism comprises an ultra-sonically welded -molded portion of the dielectric mounting substrate that holds and the metal dipole in place on a surface of the dielectric mounting substrate.

36. A method of fabricating a radiating element for a base station antenna, the method comprising:

forming first through fourth metal dipole arms from one or more sheets of metal;
forming a dielectric mounting substrate via injection molding;
mounting the first through fourth metal dipole arms to the dielectric mounting substrate via an attachment mechanism; and
mounting the dielectric mounting substrate having the first through fourth metal dipole arms mounted thereon on a feed stalk.

37. The method of Claim 36, wherein the dielectric mounting substrate includes a plurality of guides, and wherein mounting the first through fourth metal dipole arms to the dielectric mounting substrate comprises:

coating an adhesive on at least one of the dielectric mounting substrate and the first through fourth metal dipole arms; and
using the guides to position the first through fourth metal dipole arms on the dielectric mounting substrate in pre-selected mounting positions.

38. The method of Claims 36 or 37, wherein the first through fourth metal dipole arms include undulations.

39. The method of Claim 38, wherein the dielectric mounting substrate includes undulations that conform to the respective undulations of the first through fourth metal dipole arms.

40. The method of any of Claims 33-39, wherein each of the first through fourth metal dipole arms has first and second spaced-apart conductive segments that together form a generally oval shape.

41. The method of Claim 40, wherein distal ends of the first and second conductive segments of the first metal dipole arm are electrically connected to each other so that the first metal dipole arm has a closed loop structure.

42. The method of Claim 40, wherein each of the first and second conductive segments of the first through fourth metal dipole arms includes a first widened section that has a first average width, a second widened section that has a second average width and a narrowed section that has a third average width, the narrowed section being between the first widened section and the second widened section, wherein the third average width is less than half the first average width and less than half the second average width

43. The method of Claim 42, wherein the narrowed section comprises a meandered conductive trace.

44. The method of Claim 42, wherein the narrowed section creates a high impedance for currents that are at a frequency that is approximately twice the highest frequency in the operating frequency range of the radiating element.

45. The method of any of Claims 36-44, wherein the attachment mechanism comprises an over-molded portion of the dielectric mounting substrate that holds and the first through fourth metal dipole arms in place on a surface of the dielectric mounting substrate.

46. The method of any of Claims 36-44, wherein the attachment mechanism comprises a double-sided adhesive tape.

47. The method of any of Claims 36-44, wherein the attachment mechanism comprises one or more mechanical fasteners.

48. The method of any of Claims 36-44, wherein the attachment mechanism comprises an ultra-sonically welded portion of the dielectric mounting substrate that holds and the first through fourth metal dipole arms in place on a surface of the dielectric mounting substrate.

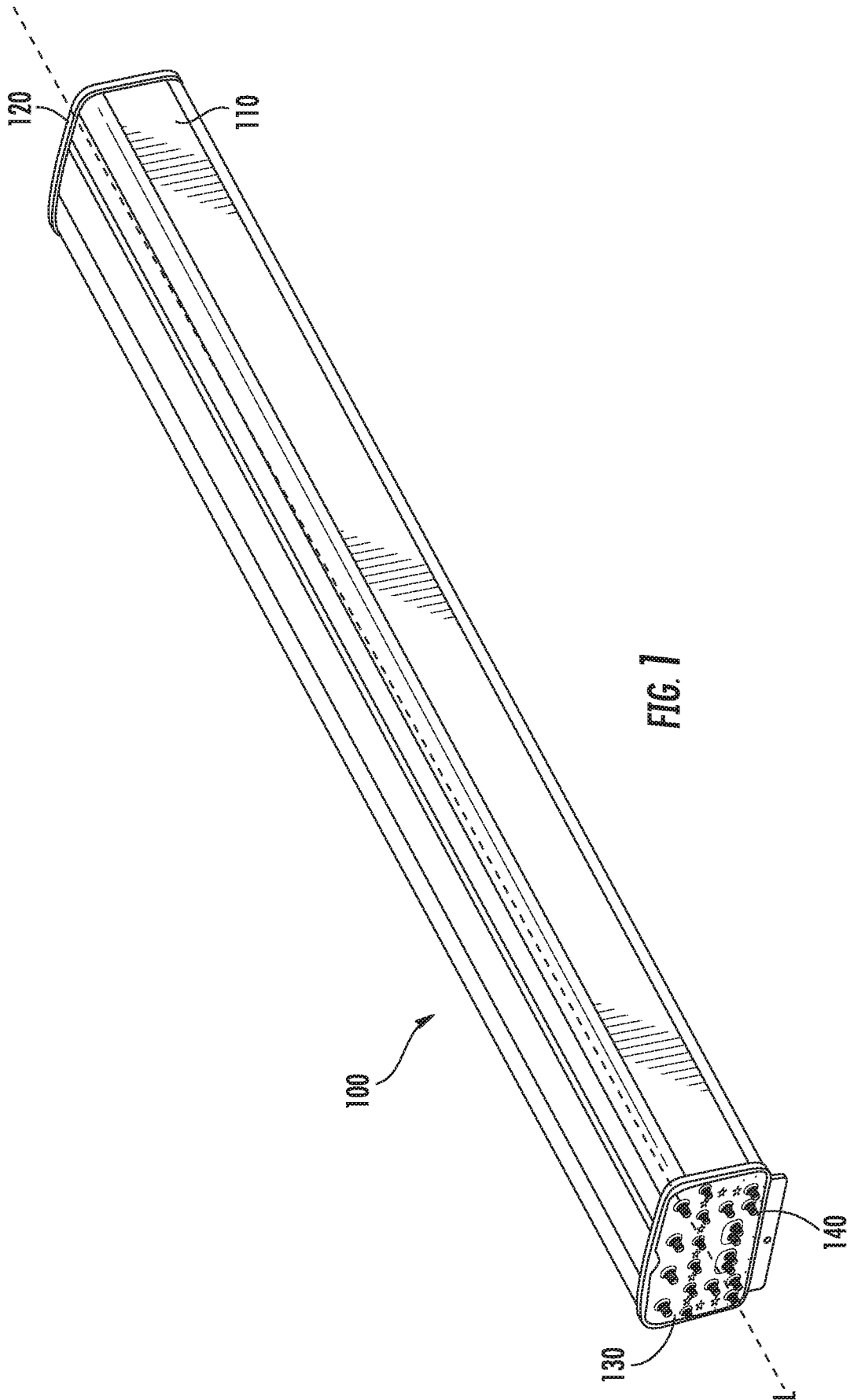

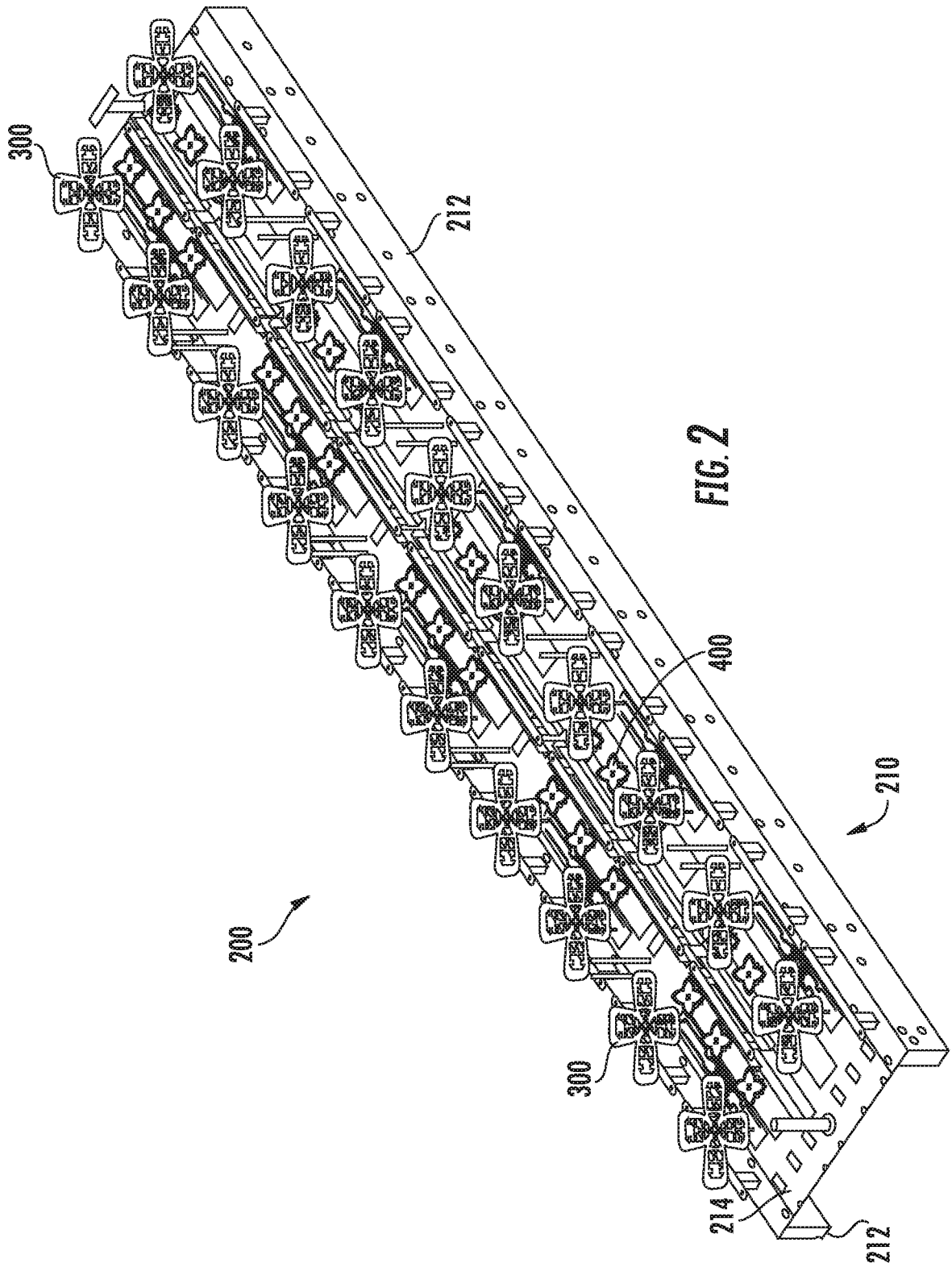

3/13

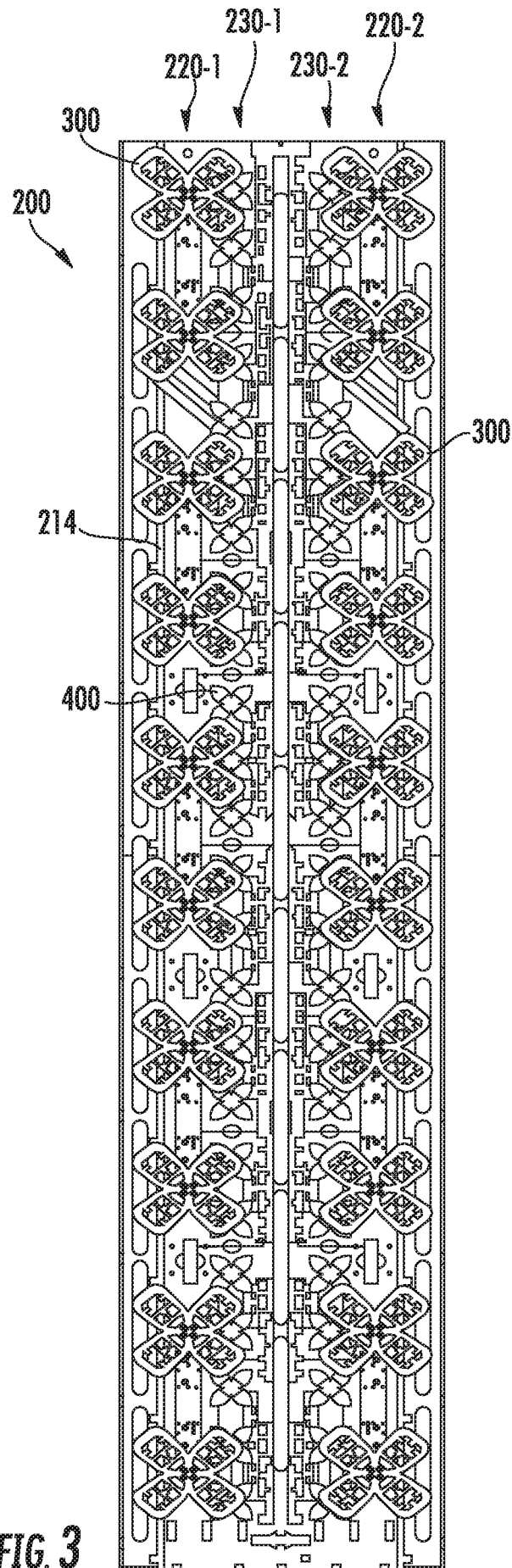

FIG. 3

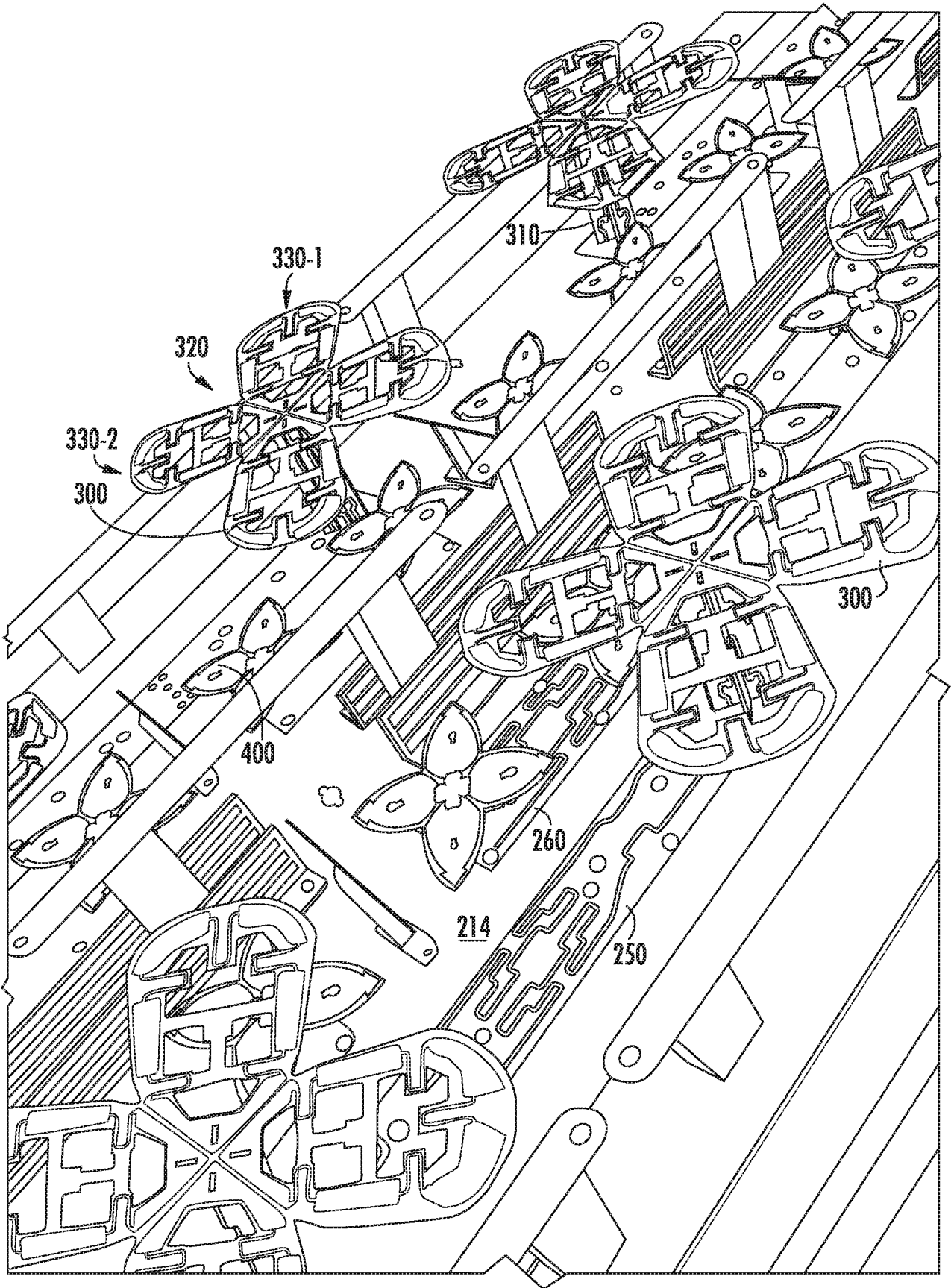
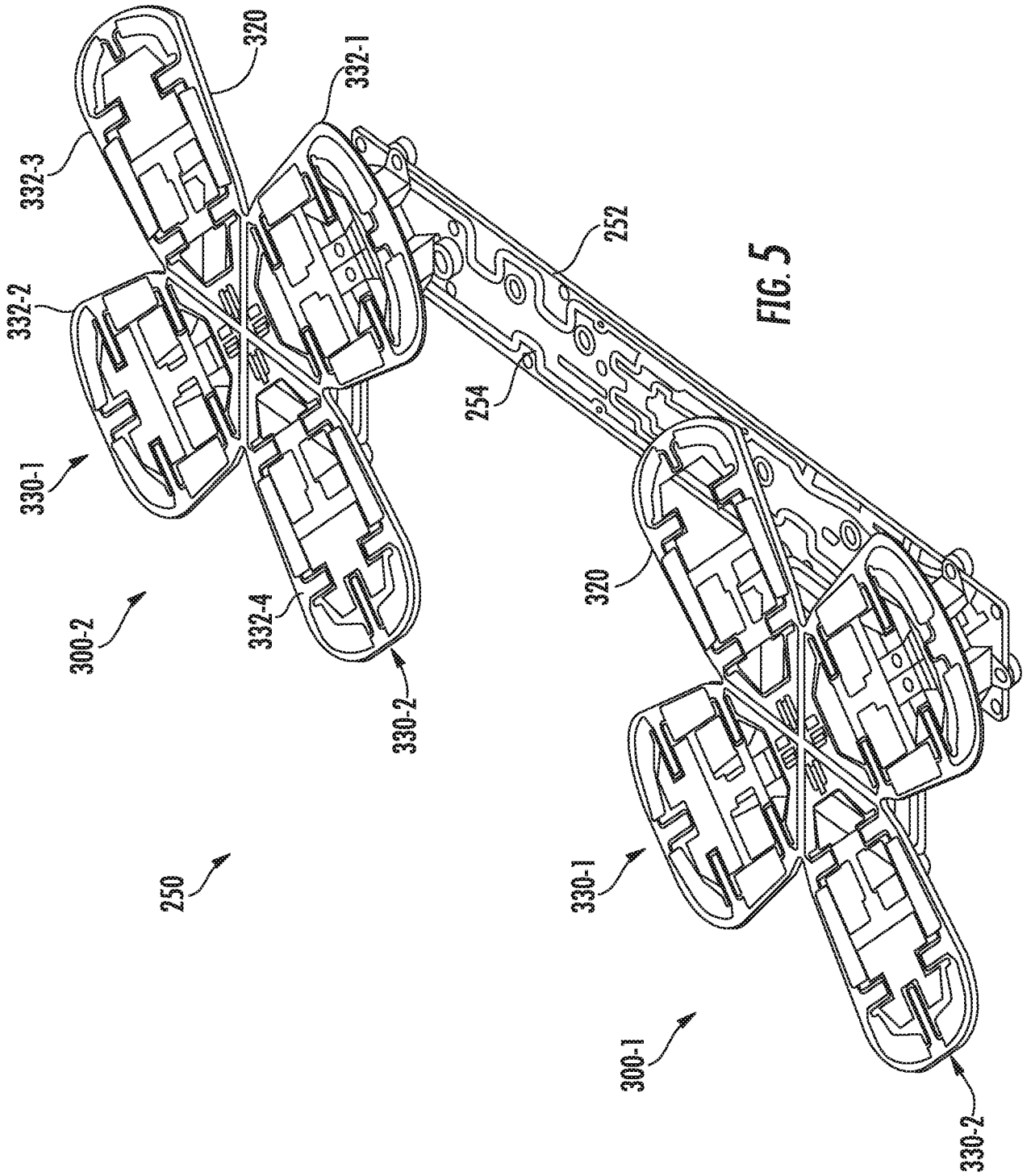

FIG. 4



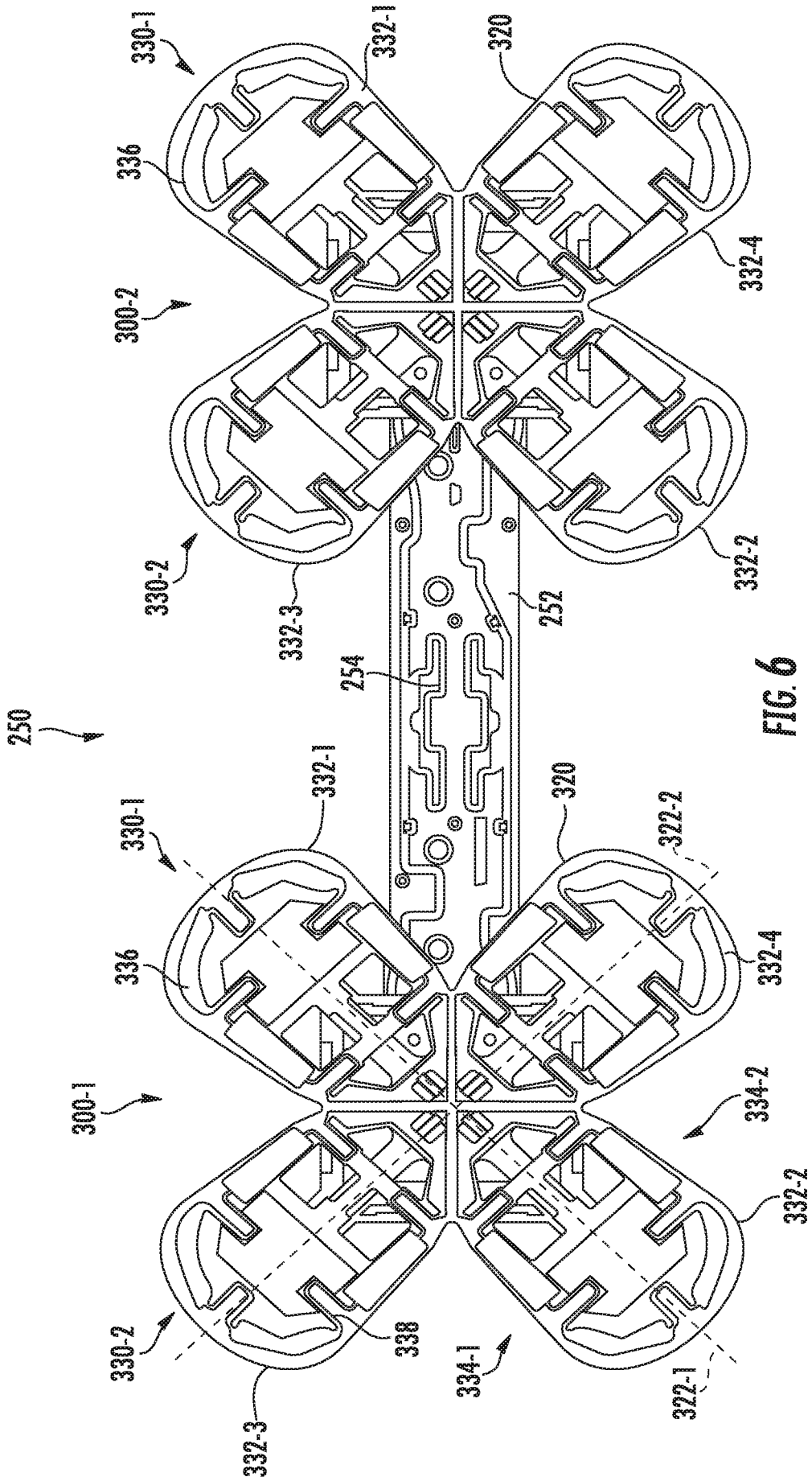

FIG. 6

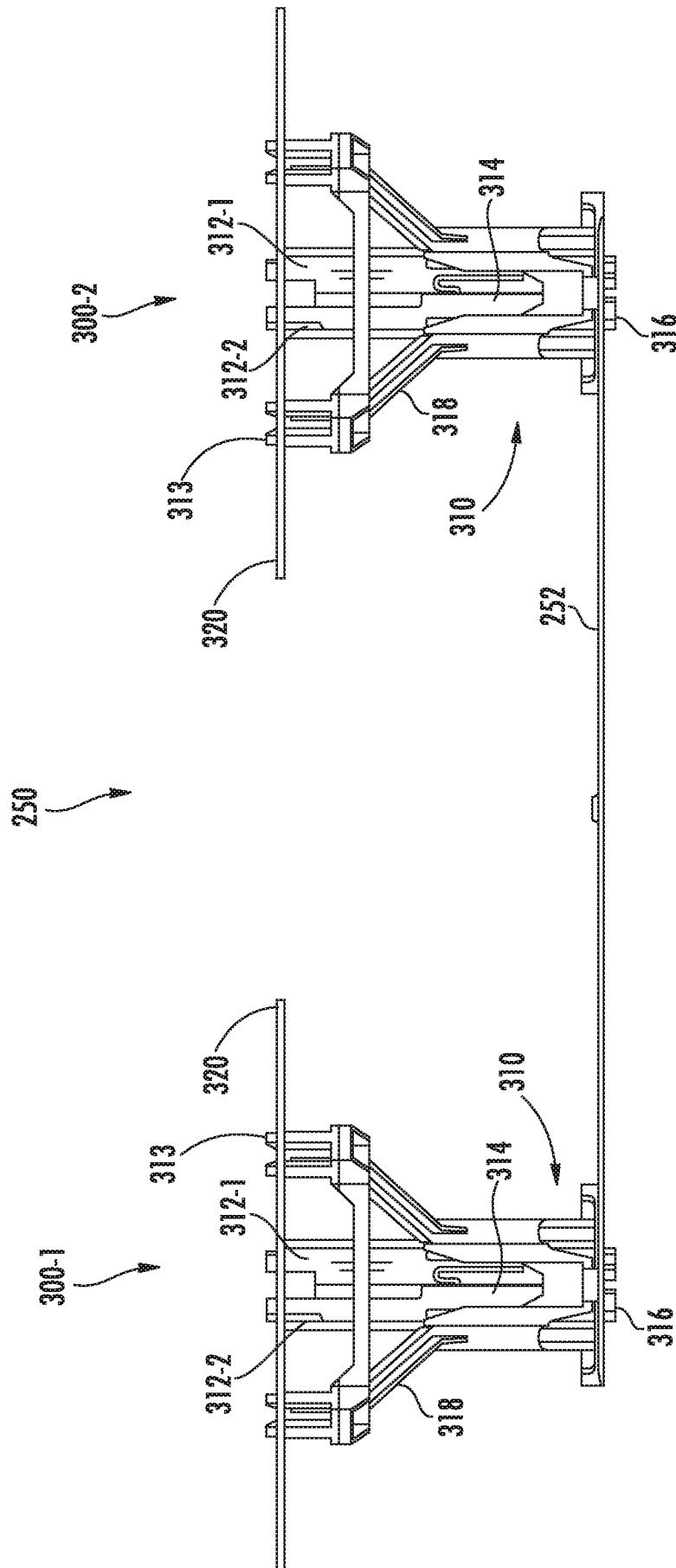

FIG. 7

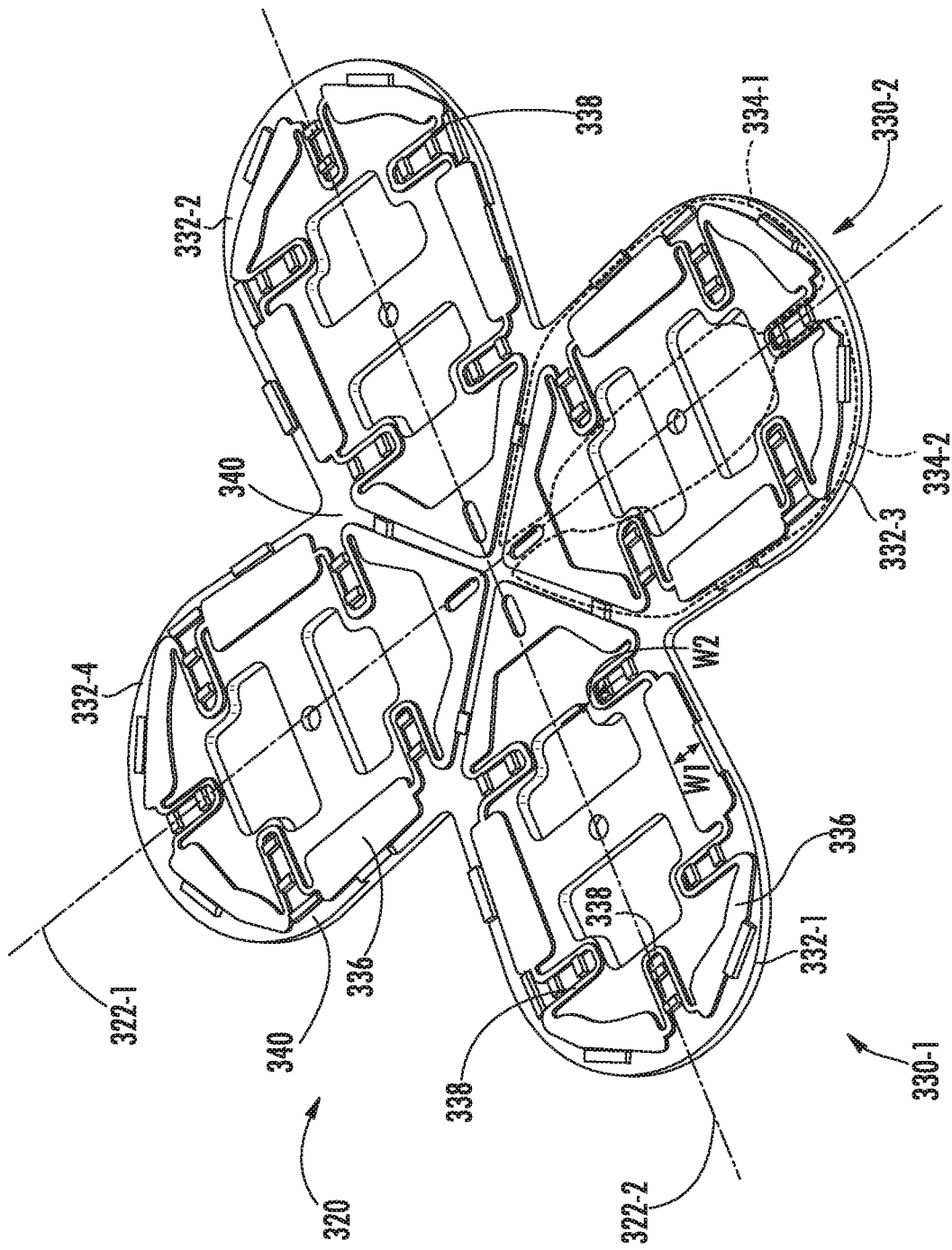

FIG. 8A

9/13

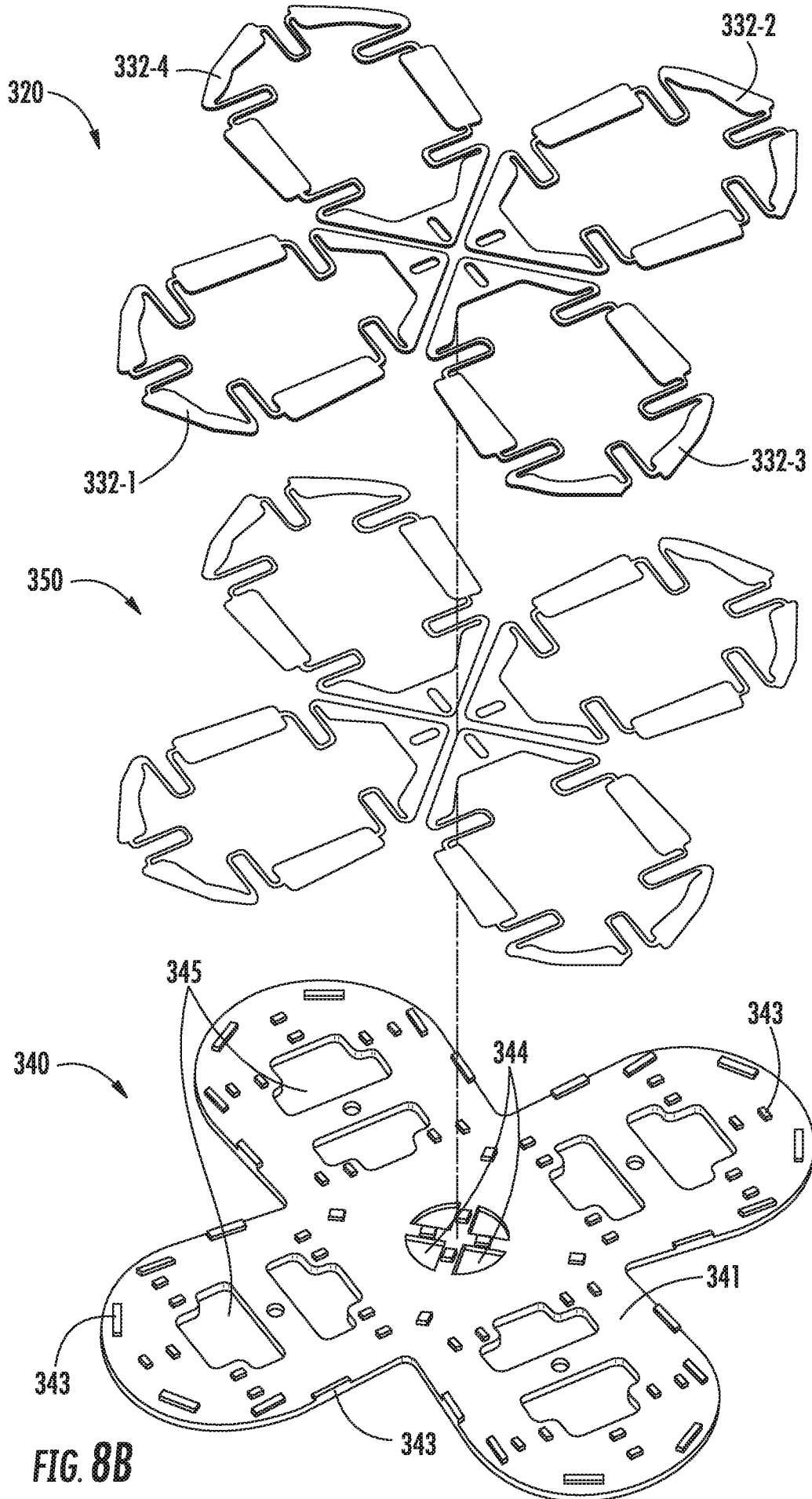
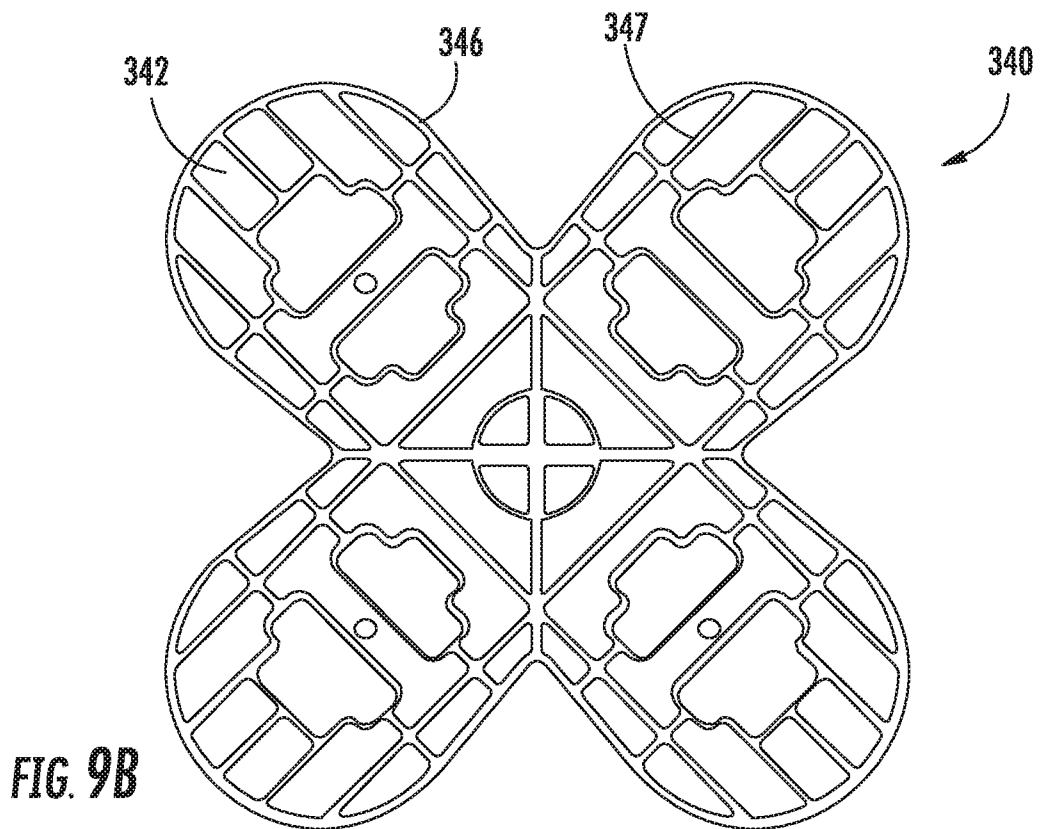
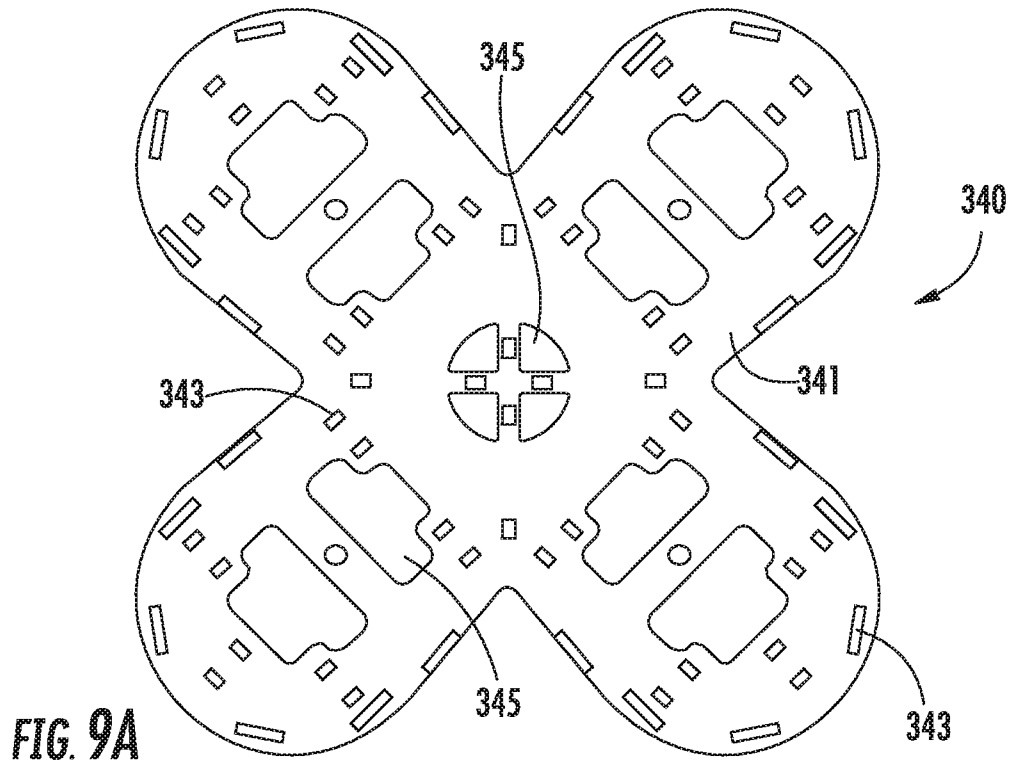
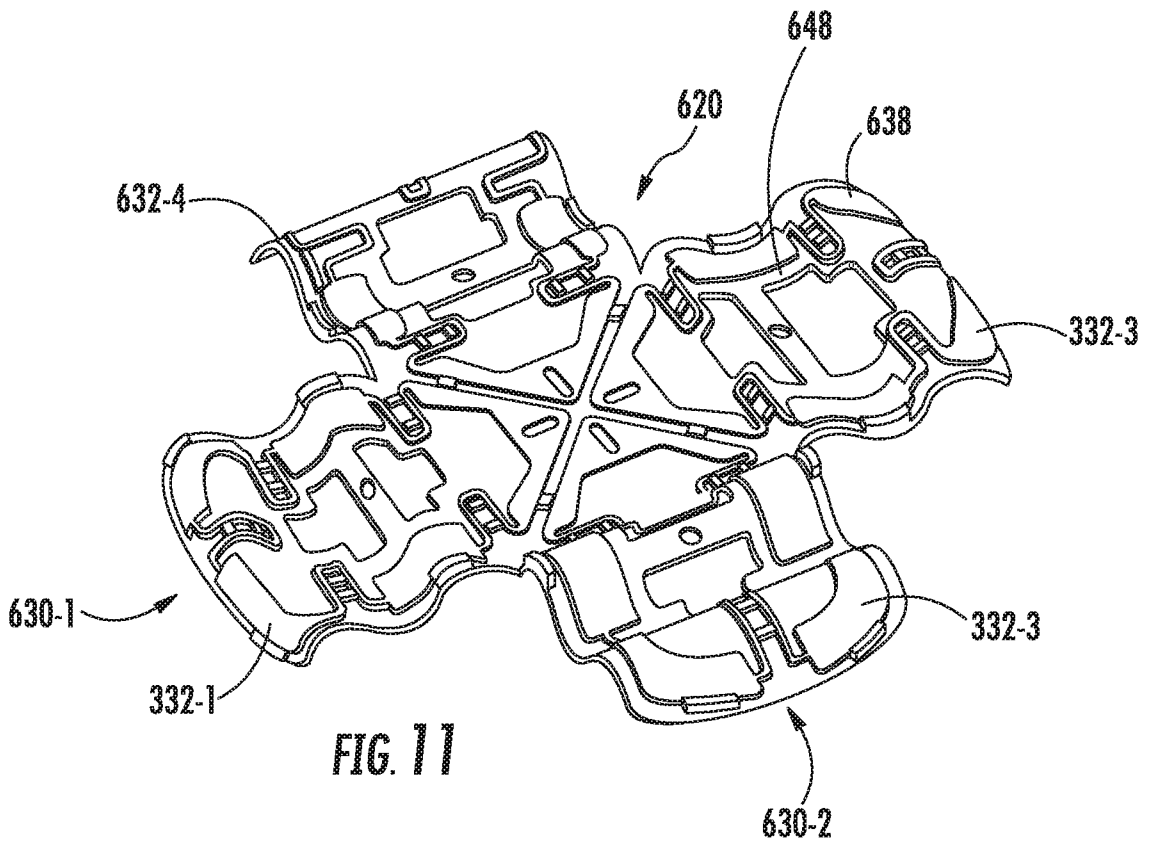
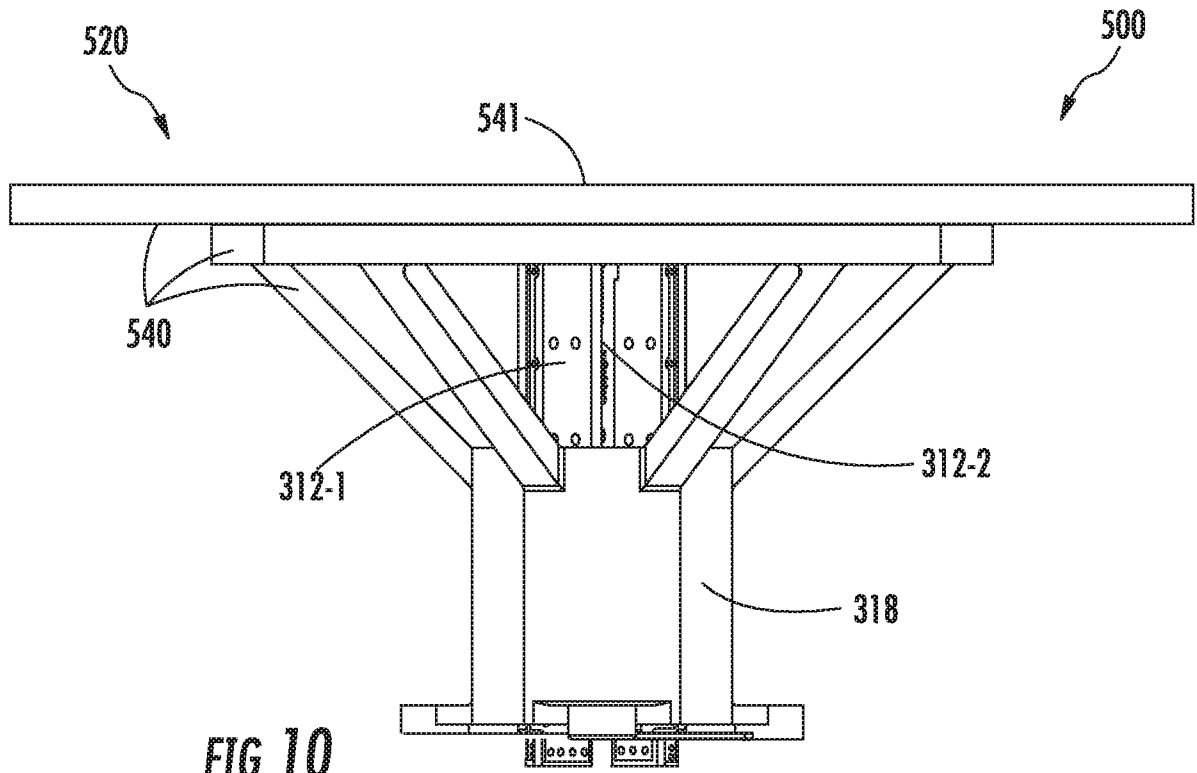

FIG. 8B





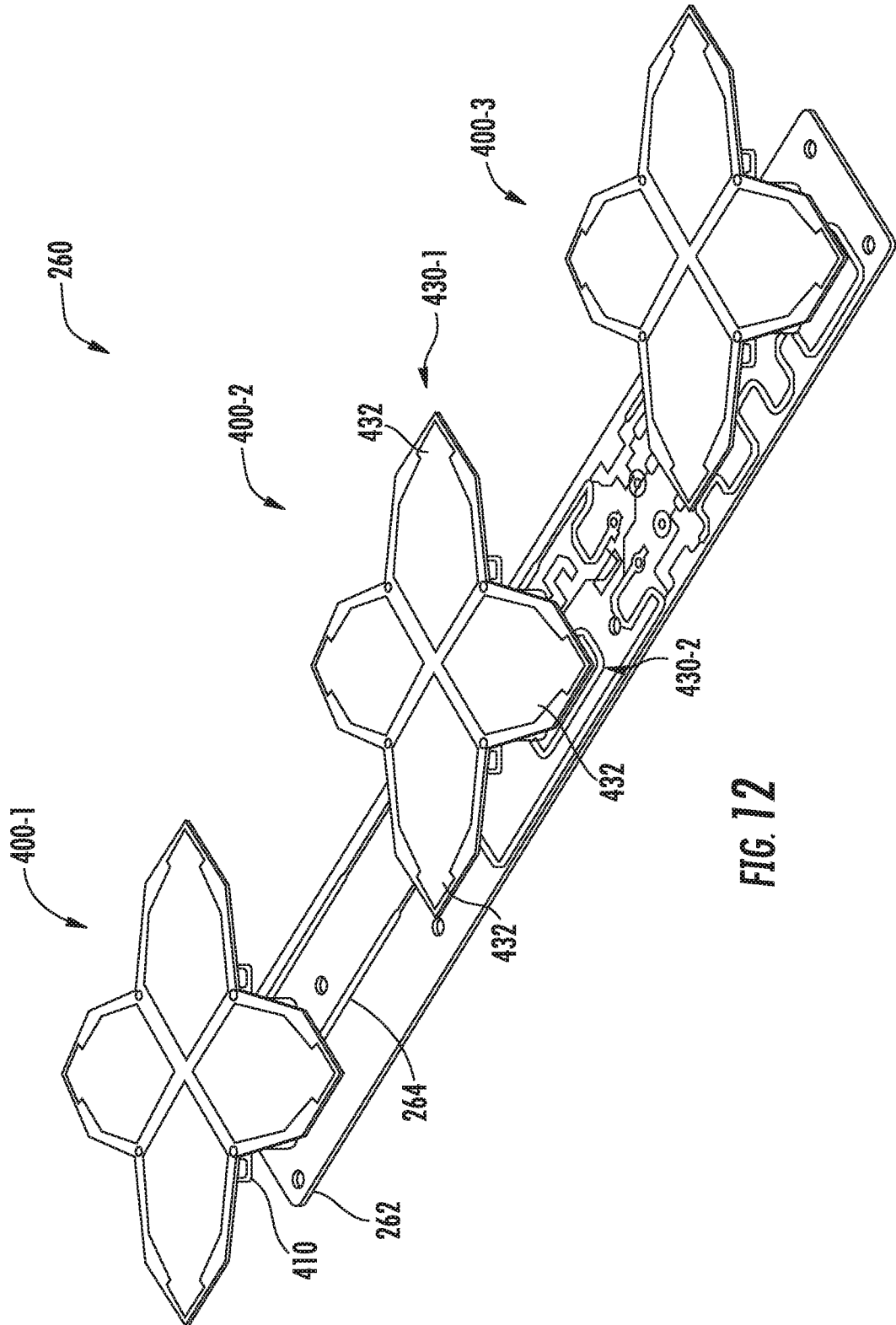
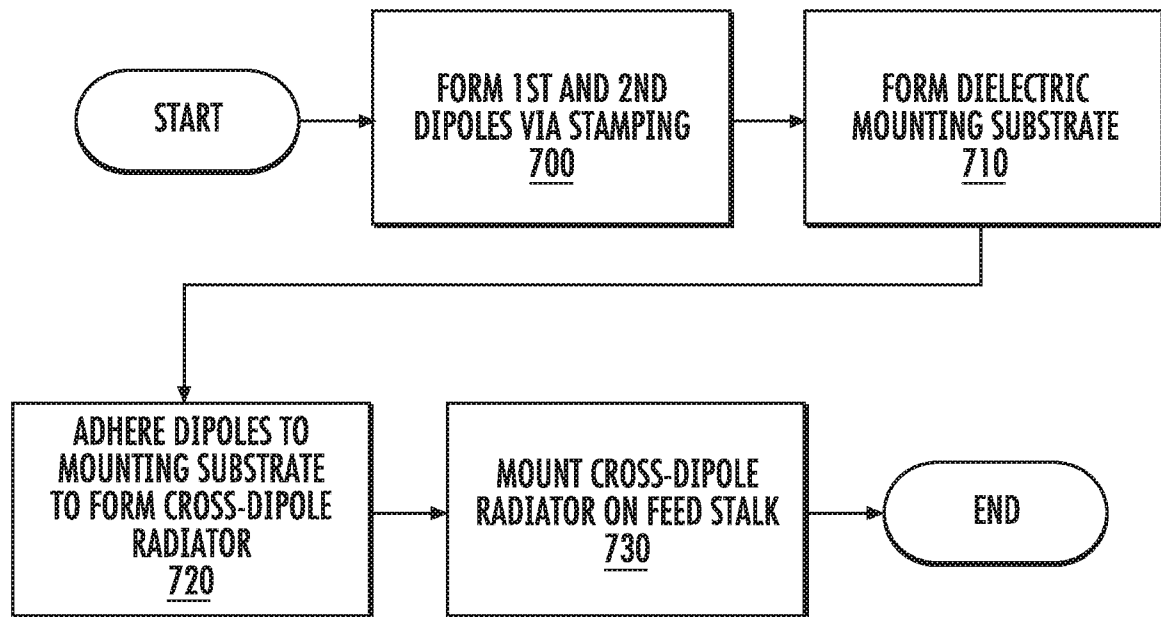

FIG. 12

13/13

**FIG. 13**

INTERNATIONAL SEARCH REPORT

International application No.

PCT/US 18/30606

A. CLASSIFICATION OF SUBJECT MATTER
 IPC(8) - H01Q 21/28; H01Q 21/26; H01Q 9/28 (2018.01)
 CPC - H01Q21/28; H01Q21/26; H01Q9/16

According to International Patent Classification (IPC) or to both national classification and IPC

B. FIELDS SEARCHED

Minimum documentation searched (classification system followed by classification symbols)

See Search History Document

Documentation searched other than minimum documentation to the extent that such documents are included in the fields searched

See Search History Document

Electronic data base consulted during the international search (name of data base and, where practicable, search terms used)

See Search History Document

C. DOCUMENTS CONSIDERED TO BE RELEVANT

Category*	Citation of document, with indication, where appropriate, of the relevant passages	Relevant to claim No.
Y --- A	US 2015/0070234 A1 (ANDREW LLC) 12 March 2015 (12.03.2015), entire document, especially; FIG 1, 4A, para [0002], [0030]-[0032].	1-5, 10, 11, ----- 6, 7, 12-14, 18-23, 25-29, 36-39
Y --- A	US 6,067,053 A (RUNYON et al.) 23 May 2000 (23.05.2000), entire document, especially; col 1, ln 10-15, col 4, ln 3-37, col 6, ln 28-52, col 12, ln 20-58, col 13, ln 19-49, col 14, ln 16-35.	1-5, 10, 11 ----- 6, 7, 12, 13, 14
Y --- A	US 2015/0202004 A1 (COVIDIEN LP) 23 July 2015 (23.07.2015), entire document, especially; para [0020].	3, 4, 5/(3,4), 10/(3,4), 11/(3,4) ----- 6/(3,4), 7/(3,4), 12/(3,4), 13/(3,4), 14/(3,4)
A	US 2007/0069970 A1 (ARGAMAN et al.) 29 March 2007 (29.03.2007), entire document.	1-7, 10-14, 18-23, 25-29, 36-39
A	US 2010/0171675 A1 (BORJA et al.) 08 July 2010 (08.07.2010), entire document.	1-7, 10-14, 18-23, 25-29, 36-39

Further documents are listed in the continuation of Box C.

See patent family annex.

* Special categories of cited documents:	"T" later document published after the international filing date or priority date and not in conflict with the application but cited to understand the principle or theory underlying the invention
"A" document defining the general state of the art which is not considered to be of particular relevance	"X" document of particular relevance; the claimed invention cannot be considered novel or cannot be considered to involve an inventive step when the document is taken alone
"E" earlier application or patent but published on or after the international filing date	"Y" document of particular relevance; the claimed invention cannot be considered to involve an inventive step when the document is combined with one or more other such documents, such combination being obvious to a person skilled in the art
"L" document which may throw doubts on priority claim(s) or which is cited to establish the publication date of another citation or other special reason (as specified)	"&" document member of the same patent family
"O" document referring to an oral disclosure, use, exhibition or other means	
"P" document published prior to the international filing date but later than the priority date claimed	

Date of the actual completion of the international search

02 July 2018

Date of mailing of the international search report

23 JUL 2018

Name and mailing address of the ISA/US

Mail Stop PCT, Attn: ISA/US, Commissioner for Patents
 P.O. Box 1450, Alexandria, Virginia 22313-1450
 Facsimile No. 571-273-8300

Authorized officer:

Lee W. Young

PCT Helpdesk: 571-272-4300
 PCT OSP: 571-272-7774

INTERNATIONAL SEARCH REPORT

International application No.

PCT/US 18/30606

Box No. II Observations where certain claims were found unsearchable (Continuation of item 2 of first sheet)

This international search report has not been established in respect of certain claims under Article 17(2)(a) for the following reasons:

1. Claims Nos.:
because they relate to subject matter not required to be searched by this Authority, namely:

2. Claims Nos.:
because they relate to parts of the international application that do not comply with the prescribed requirements to such an extent that no meaningful international search can be carried out, specifically:

3. Claims Nos.: 8, 9, 15-17, 24, 30-35, 40-48
because they are dependent claims and are not drafted in accordance with the second and third sentences of Rule 6.4(a).

Box No. III Observations where unity of invention is lacking (Continuation of item 3 of first sheet)

This International Searching Authority found multiple inventions in this international application, as follows:

1. As all required additional search fees were timely paid by the applicant, this international search report covers all searchable claims.
2. As all searchable claims could be searched without effort justifying additional fees, this Authority did not invite payment of additional fees.
3. As only some of the required additional search fees were timely paid by the applicant, this international search report covers only those claims for which fees were paid, specifically claims Nos.:

4. No required additional search fees were timely paid by the applicant. Consequently, this international search report is restricted to the invention first mentioned in the claims; it is covered by claims Nos.:

- Remark on Protest**
- The additional search fees were accompanied by the applicant's protest and, where applicable, the payment of a protest fee.
 - The additional search fees were accompanied by the applicant's protest but the applicable protest fee was not paid within the time limit specified in the invitation.
 - No protest accompanied the payment of additional search fees.