

12

**EUROPEAN PATENT APPLICATION**

21 Application number: **89830127.0**

51 Int. Cl.4: **A 45 B 23/00**  
**A 45 B 25/14**

22 Date of filing: **22.03.89**

30 Priority: **22.03.88 IT 477060**

43 Date of publication of application:  
**27.09.89 Bulletin 89/39**

64 Designated Contracting States:  
**BE DE ES FR GB NL**

71 Applicant: **GARDENART**  
**Via Cairoli, 22**  
**I-50136 Firenze (IT)**

72 Inventor: **Vincenzo, Aloï**  
**Via Calatafimi, 8/A**  
**Firenze (IT)**

74 Representative: **Mascioli, Alessandro, Prof.Dr.**  
**c/o A.N.D.I. Associazione Nazionale degli Inventori Via**  
**Urbana, 20**  
**I-00184 Roma (IT)**

54 **A device for the supporting without a central post and the winch opening of large sunshades and similar.**

57 The device according to the present invention comprises a supporting structure preferably out of metal tubes, consisting of a vertical post (1) solid by construction with a portion of an outwardly turned post (4) placed at an angle of about 120°; said structure is rotating following to the whole round angle, around the axis of said vertical post applied in correspondence with one side of a box container (3) or similar that may be ballasted with earth or other and that eventually may be used as a flower-pot. In correspondence with the front end of said outwardly turned portion (4) the sundshade is suspended which, by means of a cable traction means (8), operated by a handle winch (7) solid with said vertical post (1), will be opened, thus leaving free all the underneath space.

**EP 0 334 821 A2**

## Description

### A device for the supporting without a central post and the winch opening of large sunshades and similar

The present invention concerns a device for supporting, without the encumbrance of the central post, those large sunshades used in bars, restaurants, on beaches, shops, gardens and private terraces.

The device according to the present invention also comprises means for the opening and closing of said sunshades without particular efforts.

It is already well known that the large sunshades, due to the relevant dimensions of the ribs and the sheets, are particularly difficult to open and to close, and furthermore they cause a limitation of the covered surface due to the central supporting post.

It is the aim of the present invention to eliminate all mentioned inconveniences by means of a simple device, being functional and of easy handling.

The aim set forth is reached by means of the device according to the present invention for the support of large sunshades and similar, comprising a supporting structure preferably out of metal tubes, consisting of a vertical post 1 solid by construction with a portion of an outwardly turned post placed at an angle of about 120°; said structure is rotating following to the whole round angle, around the axis of said vertical post applied in correspondence with one side of a box container or similar that may be ballasted with earth or other and that eventually may be used as a flower-pot.

In correspondence with the front end of said outwardly turned portion the sunshade is suspended which, by means of a cable traction means, operated by a handle winch solid with said vertical post, will be opened, thus leaving free all the underneath space.

The advantages of the device according to the present invention are many and relevant:

- the open sunshade may cover a wide free surface without the encumbrance of the central post;
- the supporting structure and, consequently, the sunshade, may be rotated around the vertical supporting post in any direction;
- the opening and the closing of the sunshade, performed by means of the winch, take place without any effort and very quickly;
- the structure is rather stable because it is counterweighed by the flower-pot.

The present invention will be described more in detail hereinafter according to the enclosed drawings in which a preferred embodiment is shown.

Figures 1 and 2 show a perspective view of the device in the respective positions of open and closed sunshade.

Figure 3 shows a perspective view of the sheets, the ribs and the opening means in the position of open sunshade.

Figure 4 shows a perspective view of the sunshade in the intermediate opening, or eventually closing phase.

Figure 5 shows a perspective view of a variation of the device according to the present invention.

Relating now to the details of the figures, the

device according to the present invention comprises a vertical post 1, fixed decentralized on a rotatable joint 2 of 360° inside a supporting box 3 near an edge; said post 1 is solid with an outwardly turned portion 4 of a post forming a 120° angle with respect to the vertical, to the end whereof the sunshade is suspended, consisting of sheets 5 and ribs 6.

Said inclination of the outwardly turned portion 4 allows the complete opening of the underneath sunshade and nor the sheets nor the ribs will hurt against said post 1 and said portion 4.

The opening means shown in the figures comprise a winch 7, solid with said vertical post 1, for the traction of a cable 8 which, once in correspondence with the connection of the vertical post 1 and the outwardly turned portion 4, runs on a pulley 9 being housed there, and then passes through the cavity of portion 4 and by means of a guide-cable reaches the central joint element 10 of ribs 6, thus determining the lifting following to the traction and therefore the opening, or the lowering when the cable is released, and therefore the closing thereof.

The opening of the sunshade stops when said central element 10, lifted by cable 8, hurts against the stop ring 11, through which said cable 8 unrolls.

In the variant of the device according to the present invention, as shown in figure 5, instead of the flower-pot 3 a square base 3' is provided, being sufficiently heavy as to determine the steadiness of the sunshade while, at the end of the outwardly turned portion 4 the supporting joint is provided, obtained by means of a box 12 containing a swivel block 17 for the traction cable 8, suitable for the connection with the end element 16 of the sunshade following to the insertion of screws 13 and nuts 14 respectively into wholes 15 provided in box 12, and in holes 19 of said element 16.

The traction cable passes through hole 18 in box 12 and the cavity of element 16.

## Claims

1. A device for supporting without the central post and with the winch opening of large sunshades and similar, characterized in:

- a vertical post (1) fixed decentralized and rotatably on a rotating joint (2), inside a box (3);
- an outwardly portion (4) of a post, solid with the top of said vertical post (1) and forming a 120° angle with respect to the vertical;
- a sunshade consisting of ribs (6) and of sheets (5), suspended at the front end of said outwardly turned portion (4) of a post and suitable for being opened following to the vertical traction from the central element (10), until the stop against the stop-ring (11);
- opening means, suitable for the traction of cable (8), for the lifting of said central element (10) of said sunshade;
- a supporting box (3) carrying inside said

central joint (2) and that may be filled up with earth in the double function of counterweight and flower-pot.

2. A device for supporting without the central post and with the winch opening of large sunshades and similar according to claim 1, characterized in that said opening means comprise a winch (7), solid with said vertical post (1), for the traction of cable (8) which, once in correspondence to the joint between the vertical post (1) and the outwardly turned portion (4), runs on pulley (9) housed there, and then passes through the cavity in portion (4) and, by means of a guide cable, reaches the central joint element (10) of ribs (6) thus determining the lifting following to the traction, and therefore the opening, or the lowering, and

5

10

15

20

25

30

35

40

45

50

55

60

65

3

therefore the closing of the sunshade, when the cable is released.

3. A device for supporting without the central post and with the winch opening of large sunshades and similar according to claim 1, characterized in:

- a square concrete base (3');
- a box (12), placed at the end of the outwardly turned portion (4) containing the swivel block (17) and provided with passing-through holes (15);
- an end element (16) of the umbrella, crossed by holes (19);
- a connection means of the kind with screws (13) and nuts (14), passing in holes (15) of box (12), and in holes (19) of element (16).

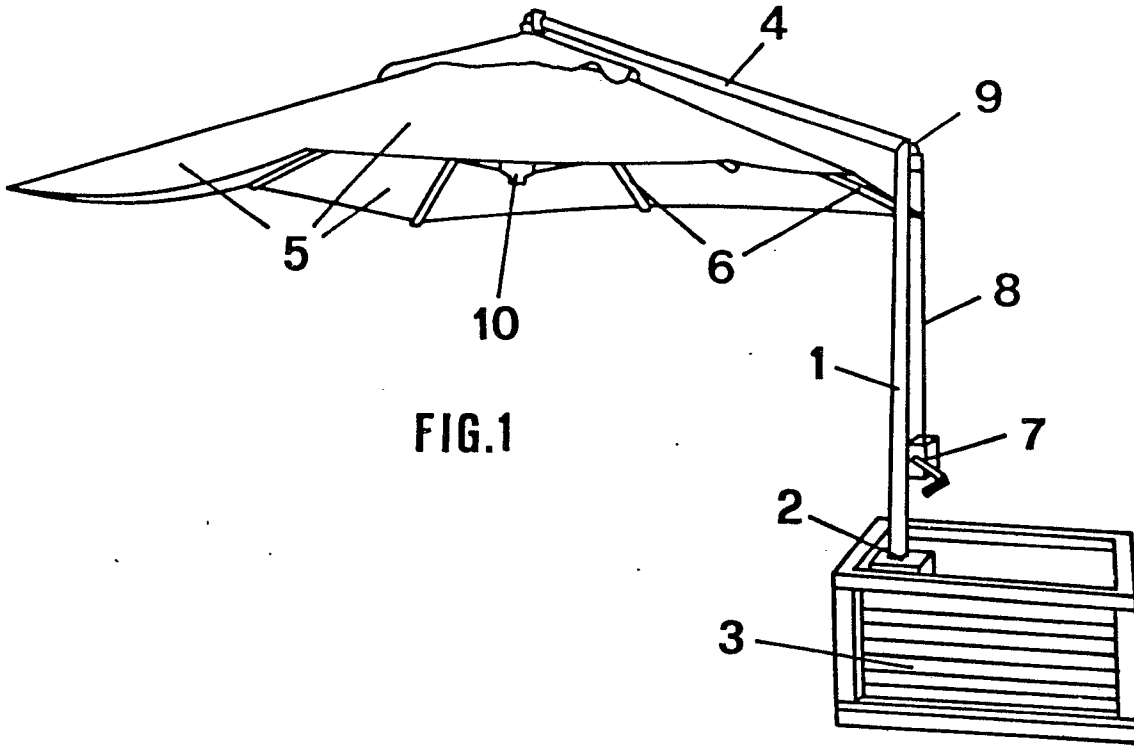

FIG. 1

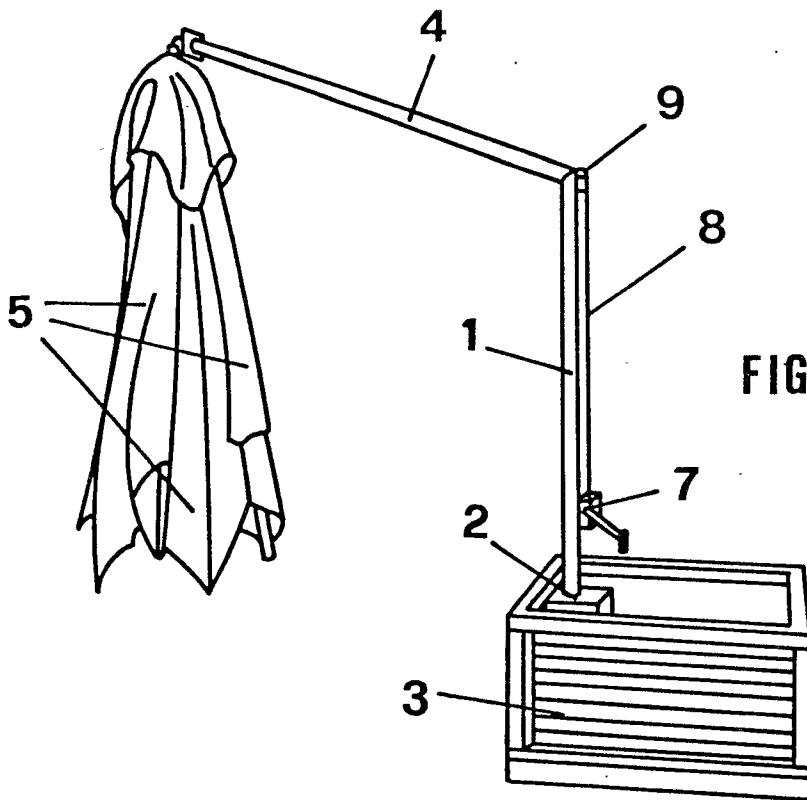

FIG. 2

FIG.3

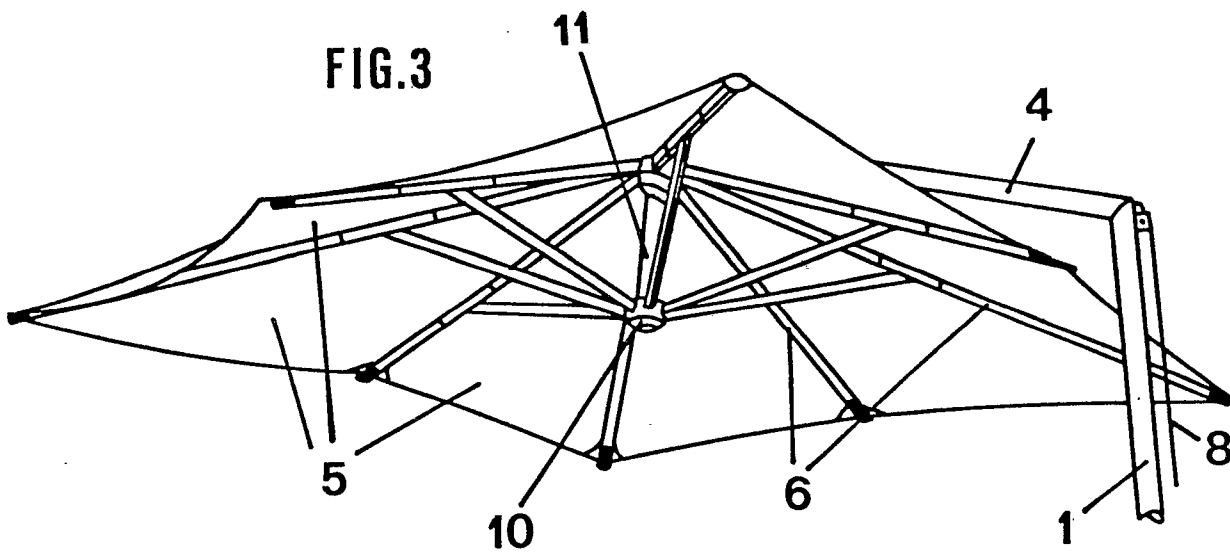

FIG.4

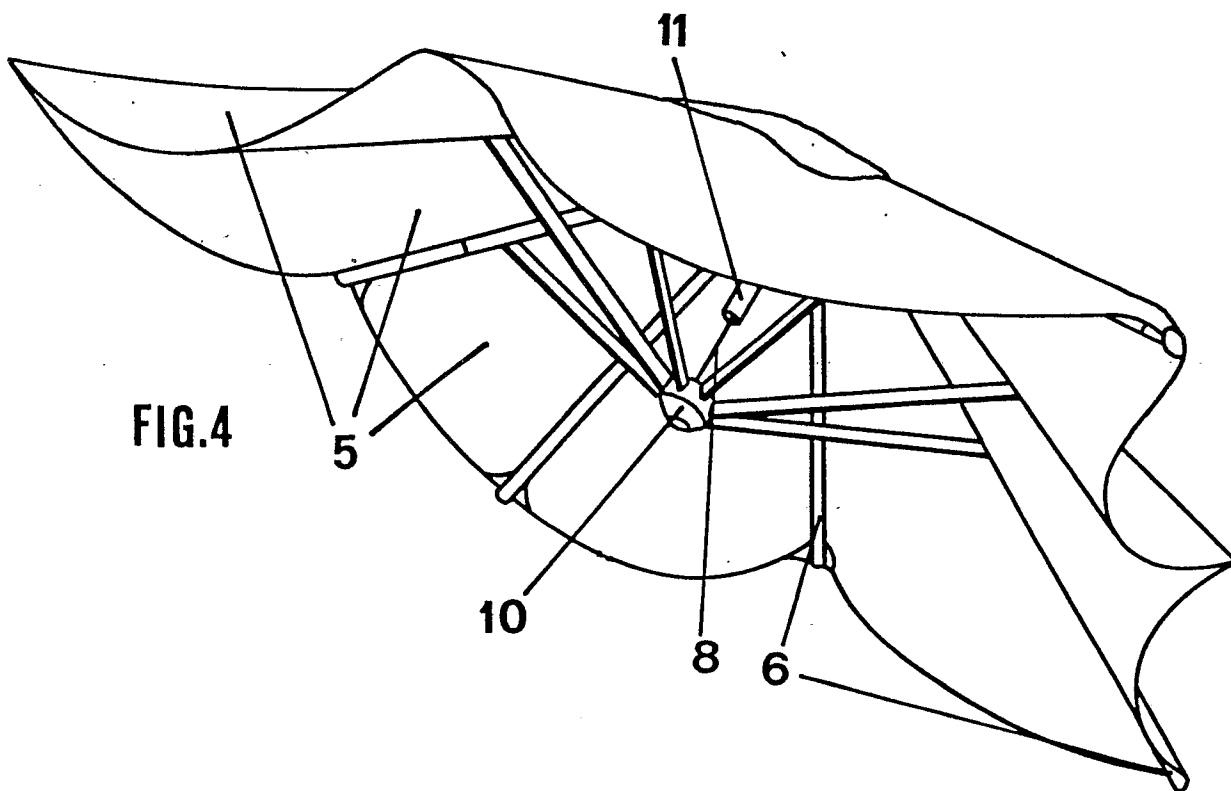

FIG.5

