



US 20040175277A1

(19) **United States**

(12) **Patent Application Publication**

Cox et al.

(10) **Pub. No.: US 2004/0175277 A1**

(43) **Pub. Date: Sep. 9, 2004**

(54) **HYDROSTATIC PUMP ASSEMBLY HAVING SYMMETRICAL ENDCAP**

Publication Classification

(76) Inventors: **C. Paul Cox**, Sellersburg (IN); **David D. Hypes**, Salem (IN); **Orville R. McDonner**, Salem (IN)

(51) **Int. Cl.⁷ F04B 19/00**

(52) **U.S. Cl. 417/239**

Correspondence Address:
BAKER & DANIELS
111 E. WAYNE STREET
SUITE 800
FORT WAYNE, IN 46802

(57) **ABSTRACT**

A hydrostatic pump assembly having a casing which encloses a pumping mechanism, and including a housing, and an endcap attached to the housing. The endcap has at least one lateral exterior surface, and a first system fluid passage having a pair of system ports located in the endcap lateral exterior surface, and a second system fluid passage having a pair of system ports located in the endcap lateral exterior surface, each of the first and second system fluid passages being in fluid communication with the pumping mechanism. In one embodiment, the pair of system ports of the first system fluid passage are located opposite each other in the endcap lateral exterior surface. The pair of system ports of the second system fluid passage may also be located opposite each other in the endcap lateral exterior surface.

(21) Appl. No.: **10/603,001**

(22) Filed: **Jun. 24, 2003**

Related U.S. Application Data

(60) Provisional application No. 60/392,401, filed on Jun. 28, 2002.

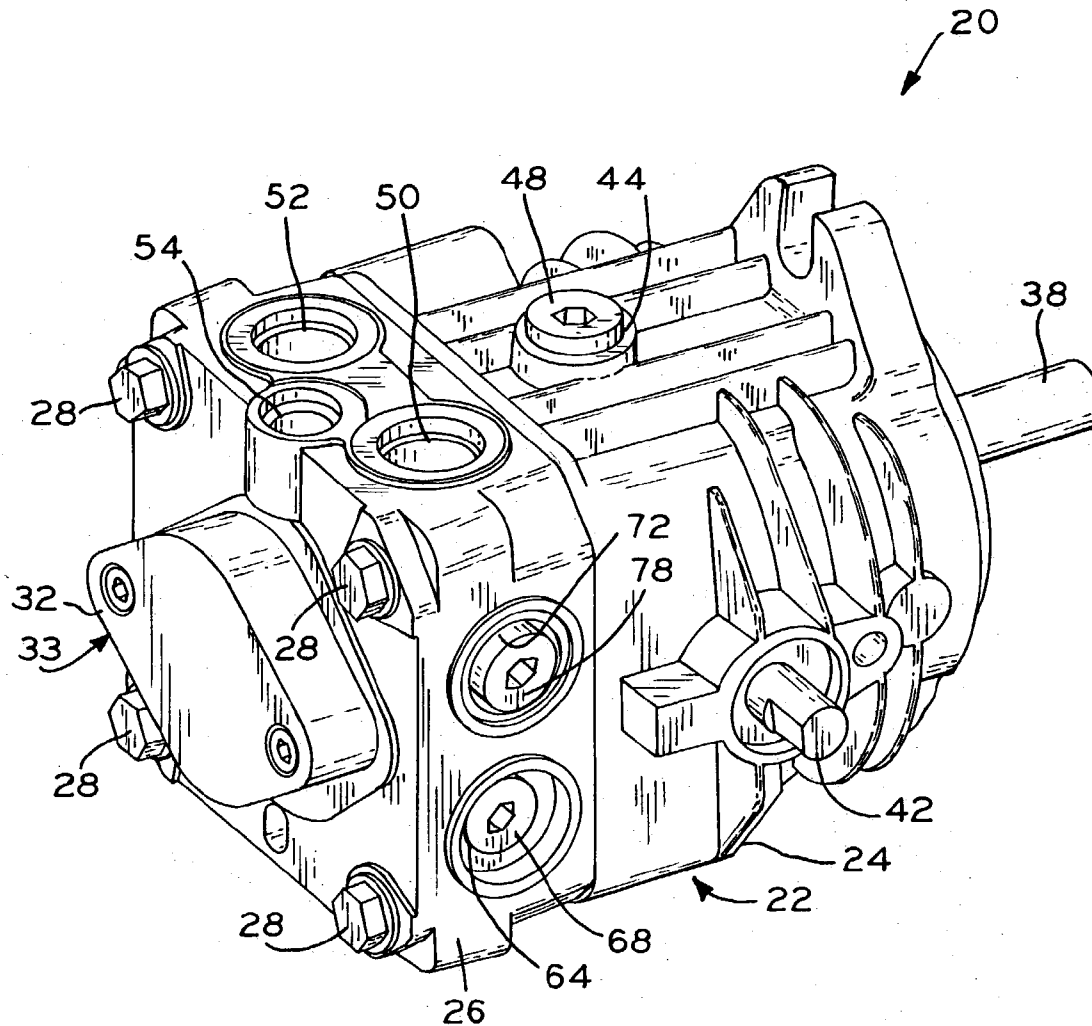

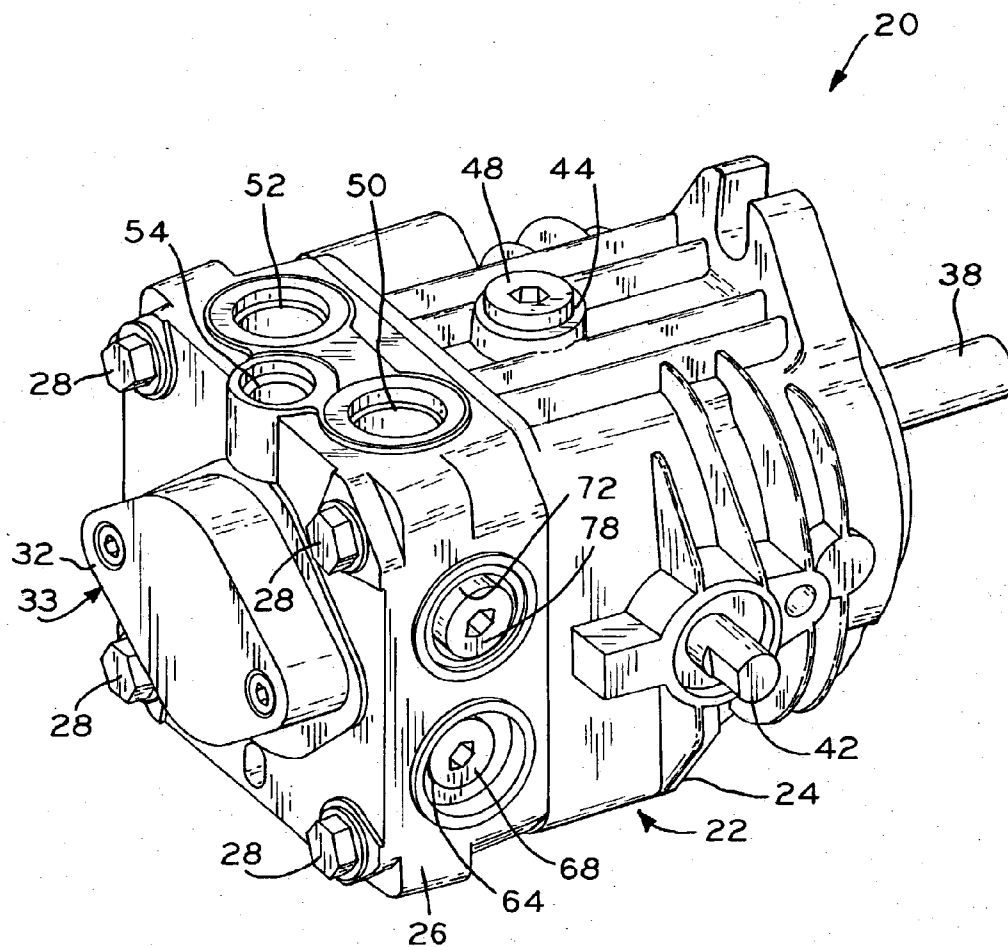

FIG. 1

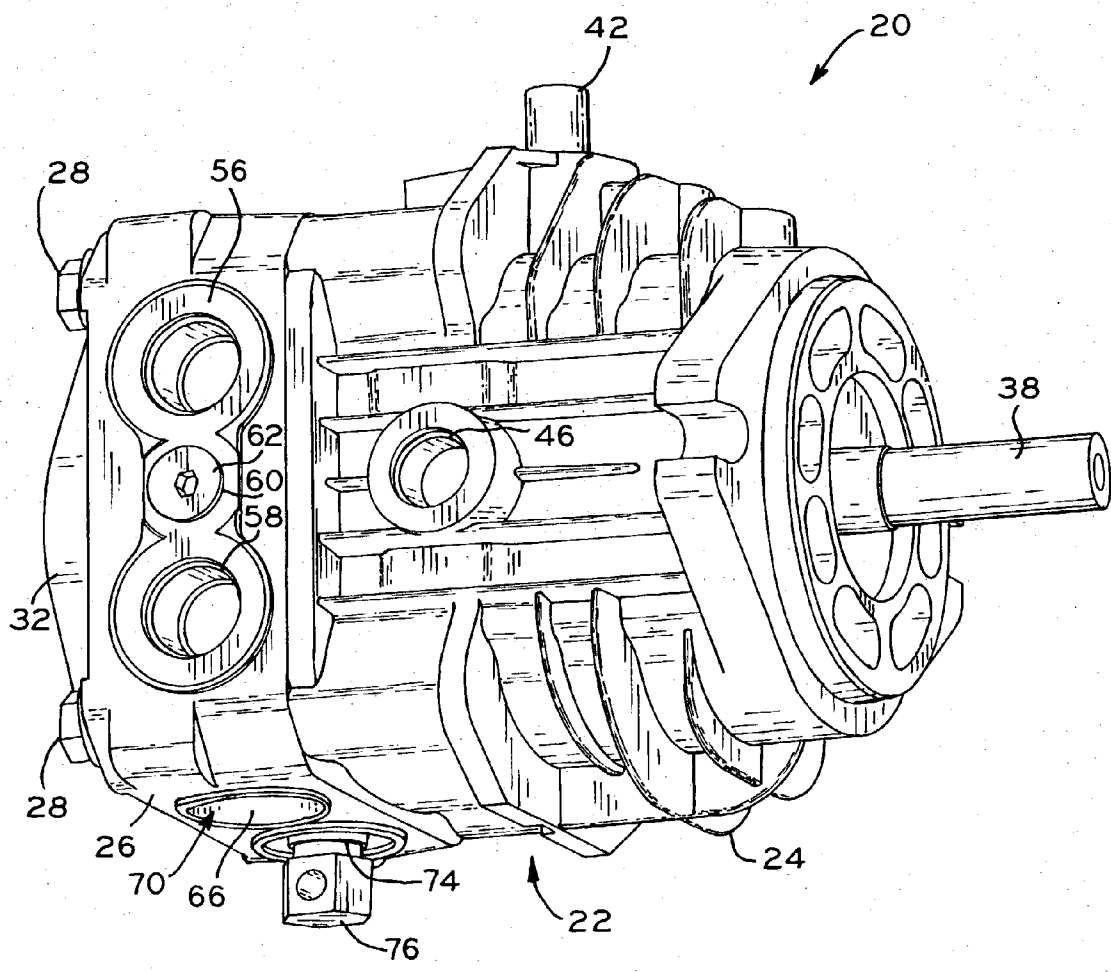

FIG. 2

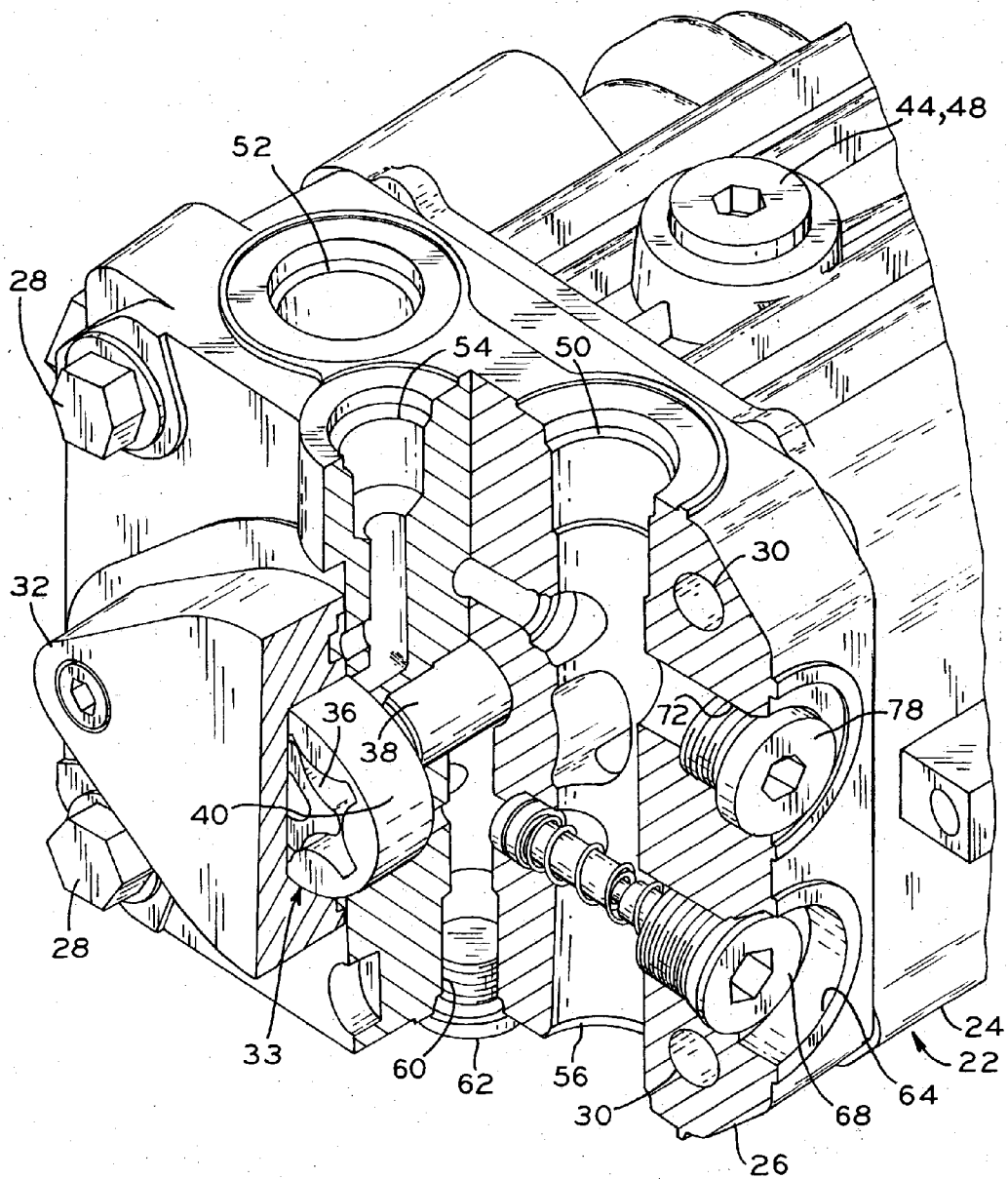

FIG. 3

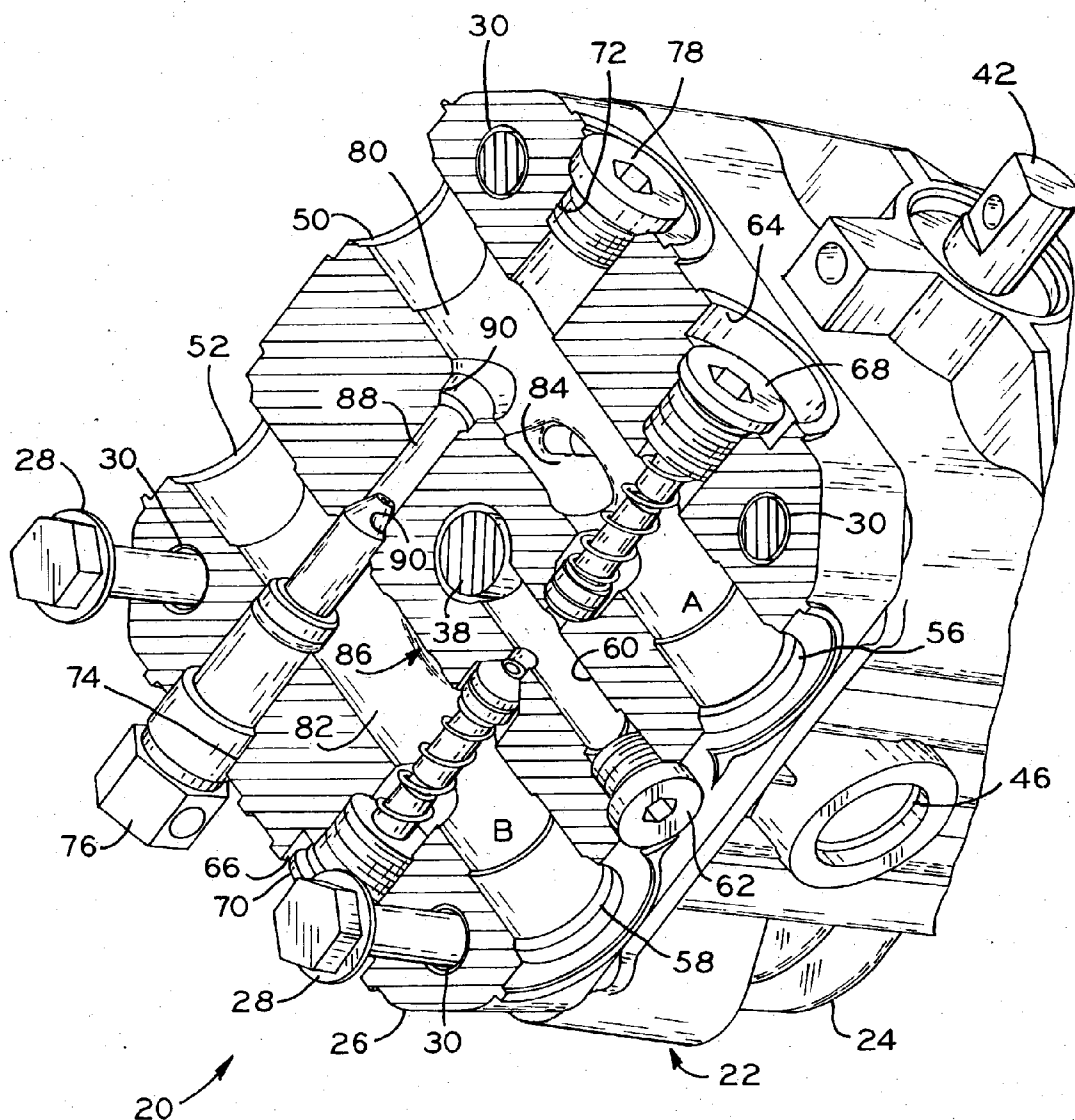

FIG. 4

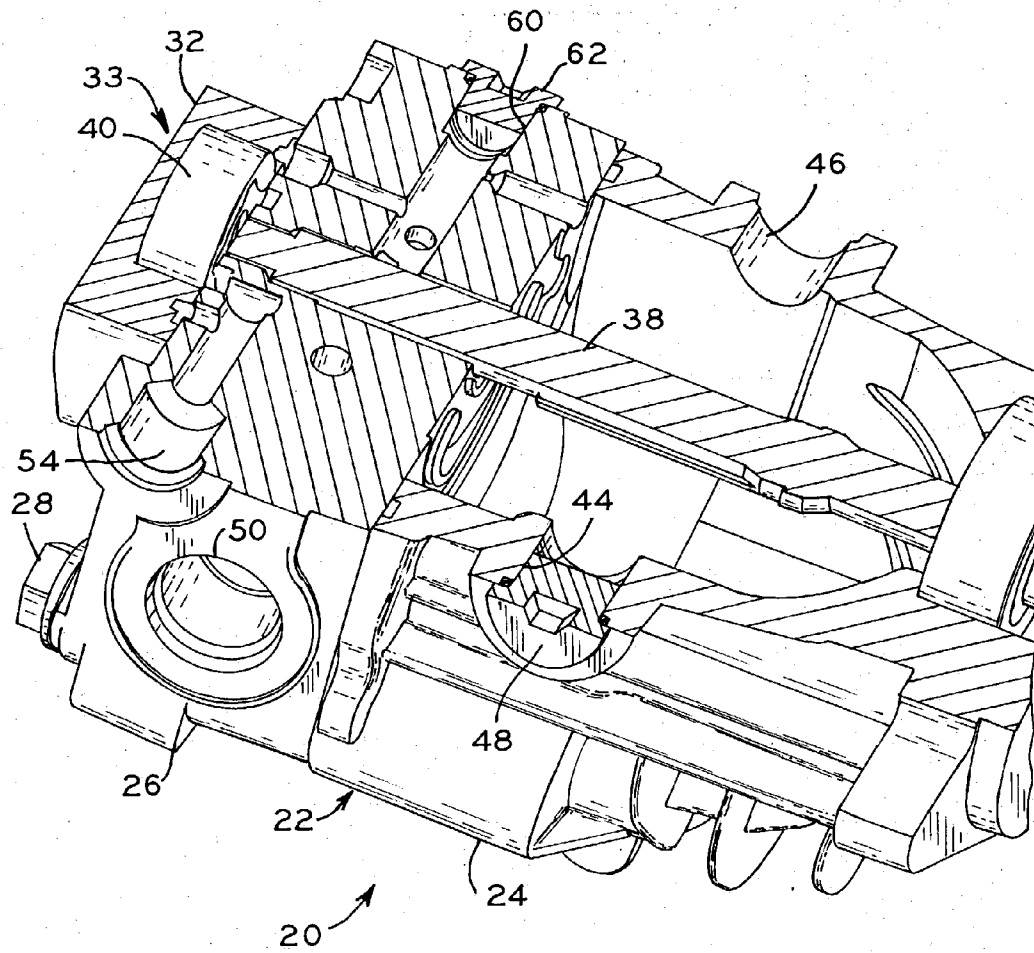
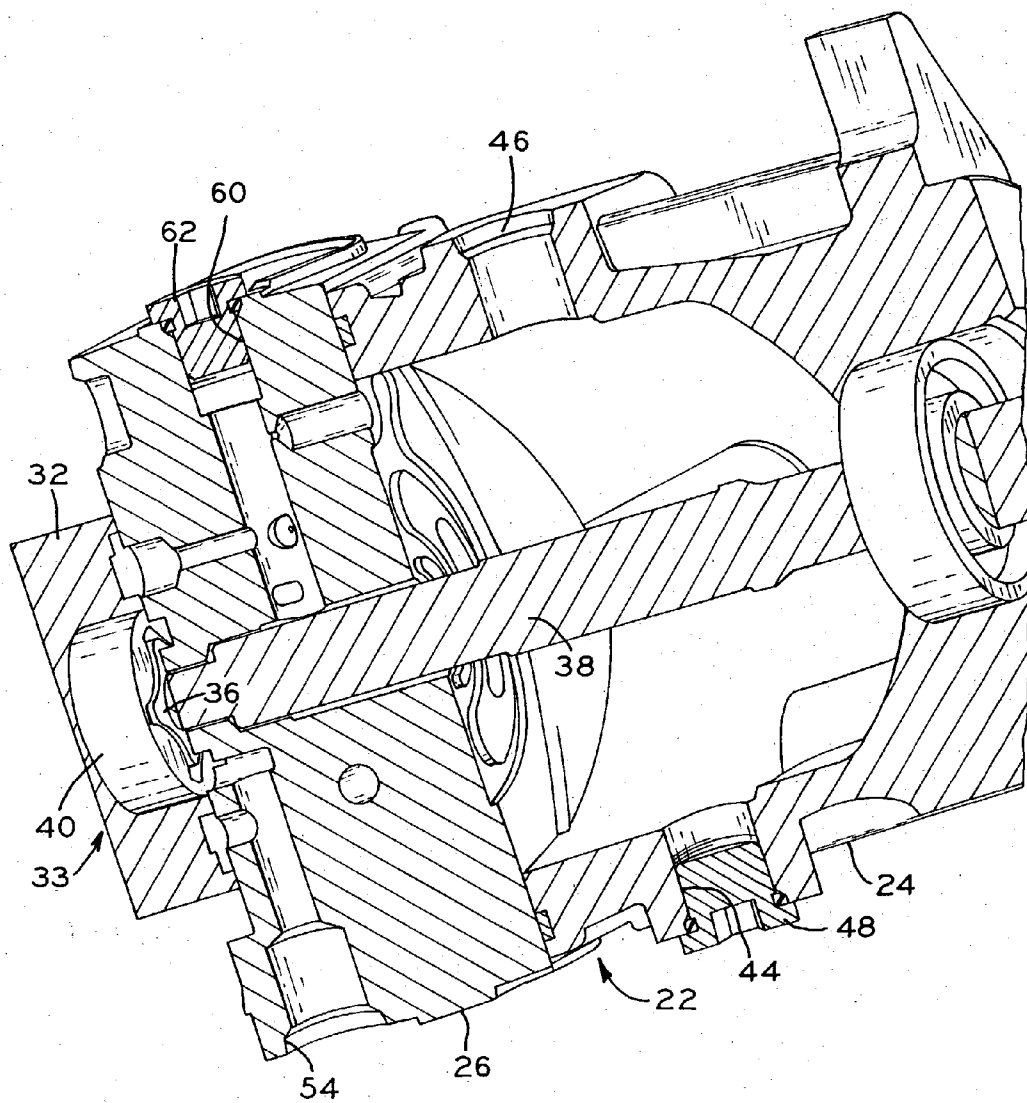

FIG. 5



20

FIG. 6

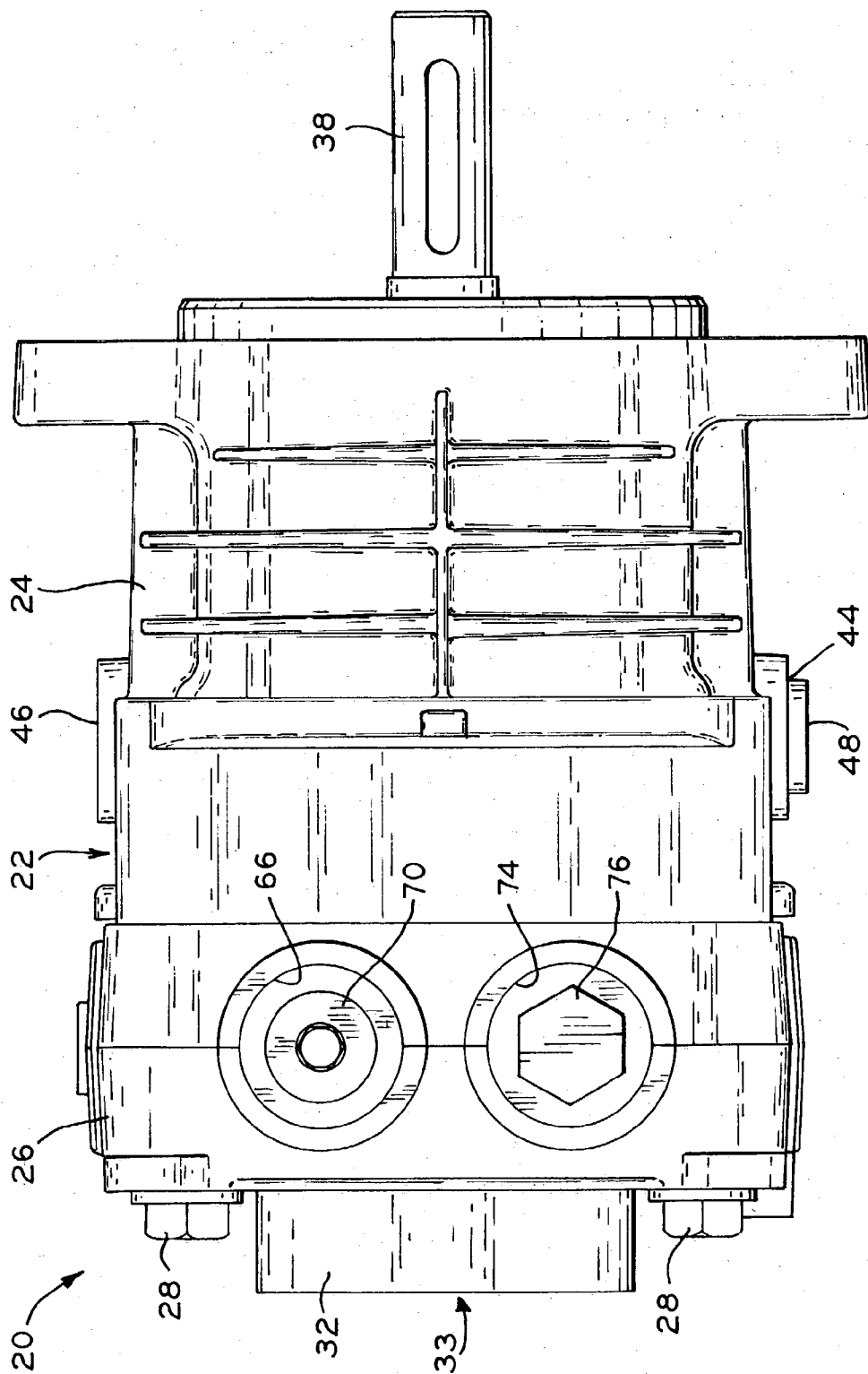

FIG. 7

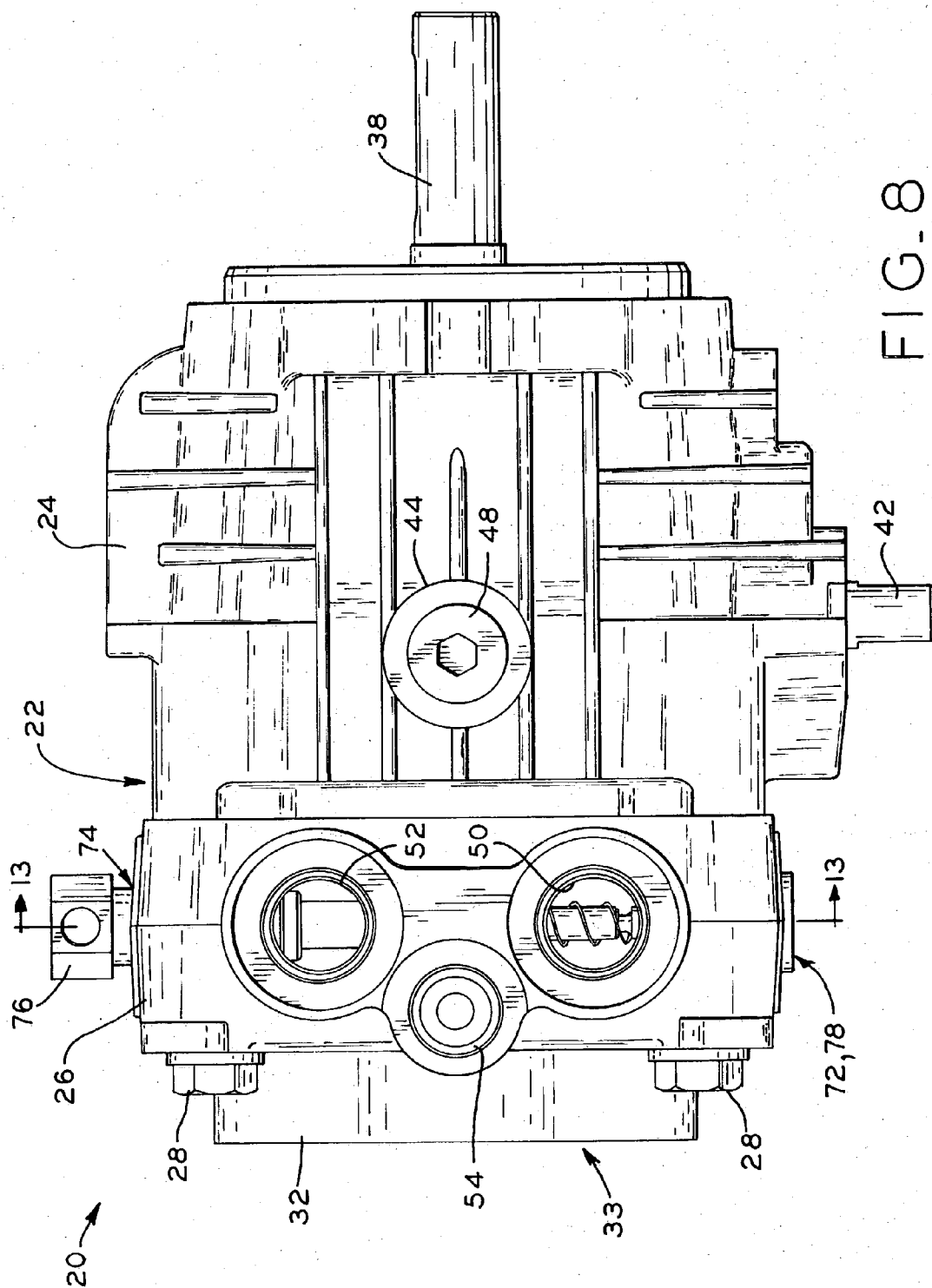

FIG. 8

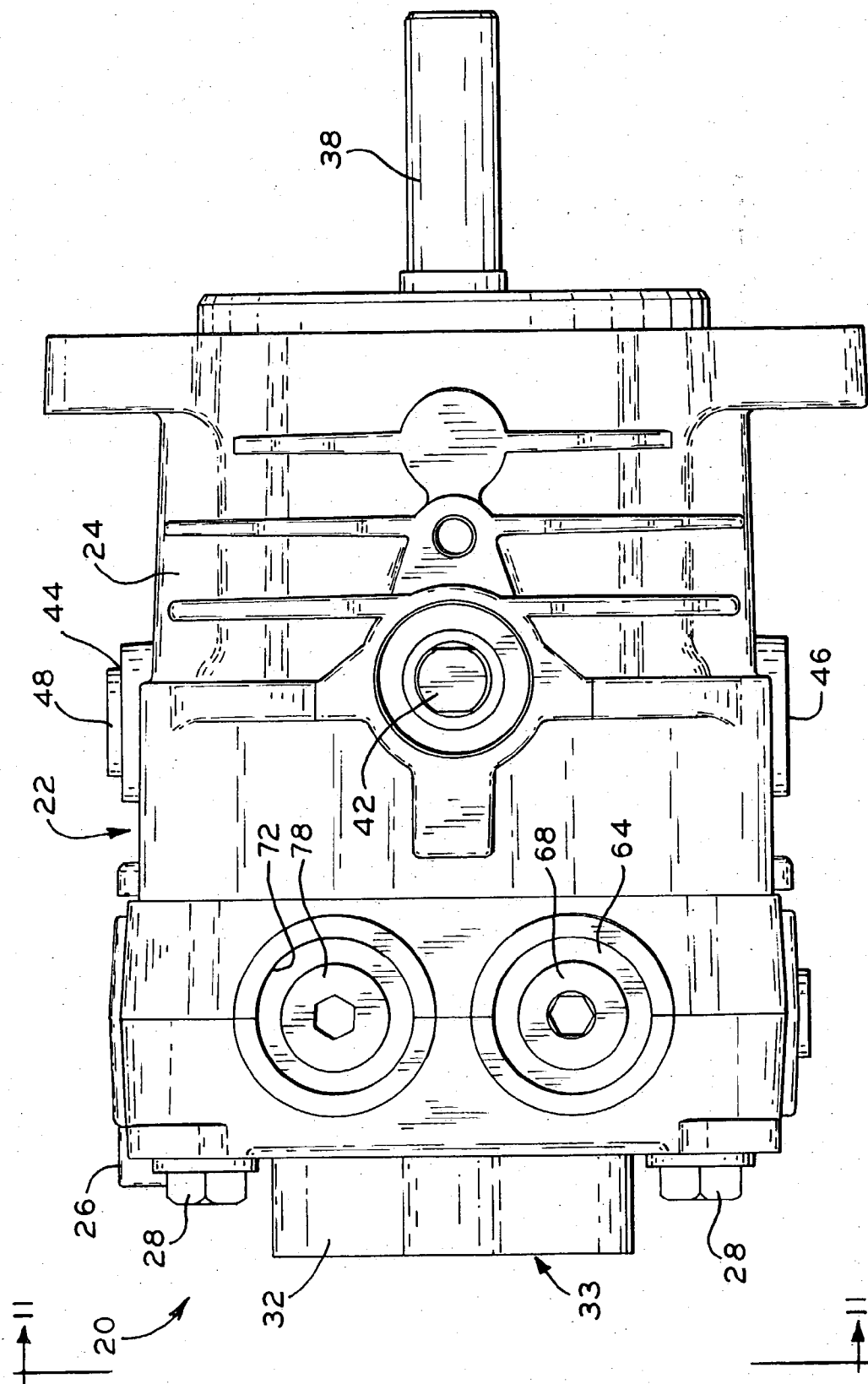

FIG. 9

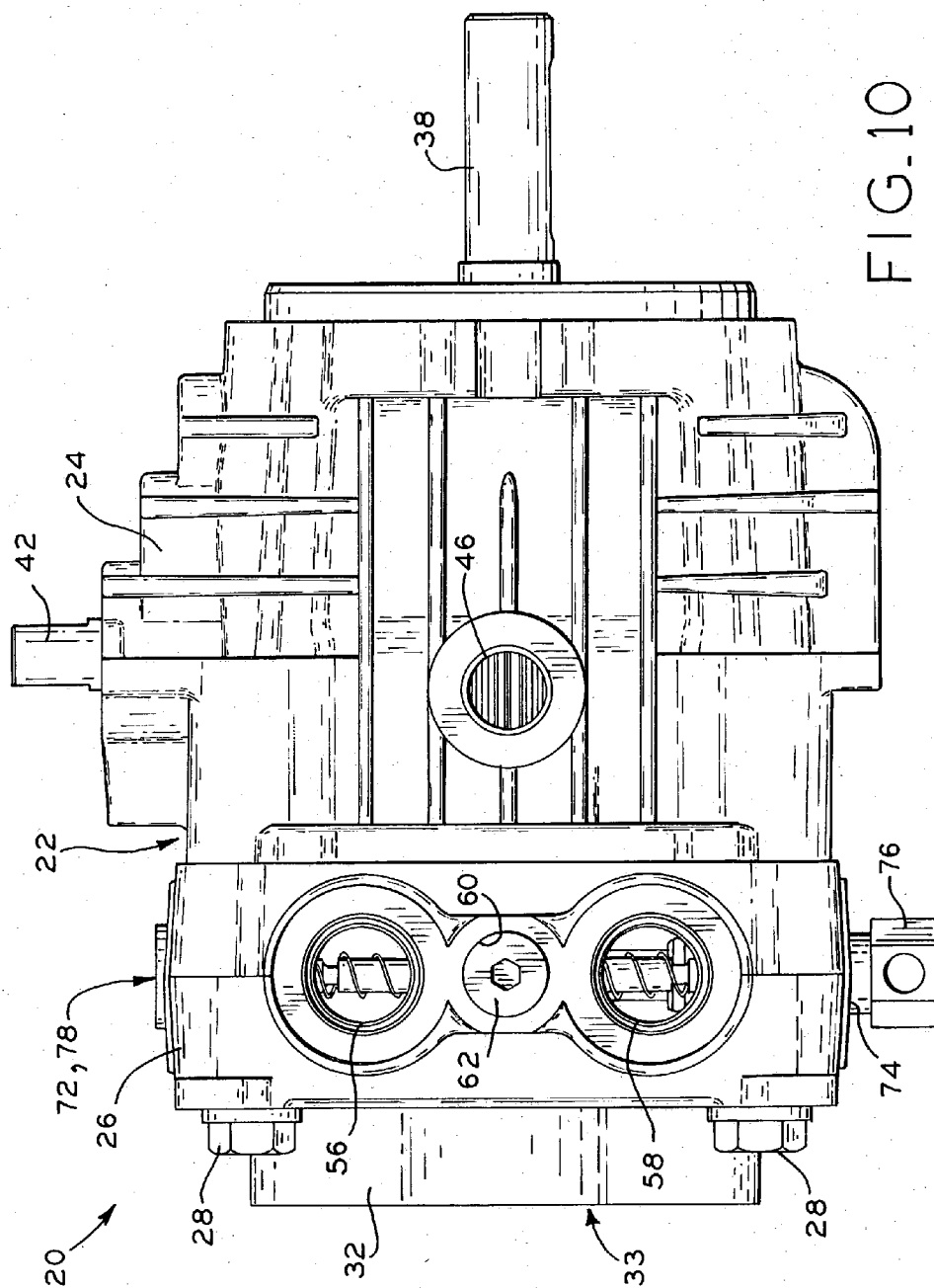

FIG. 10

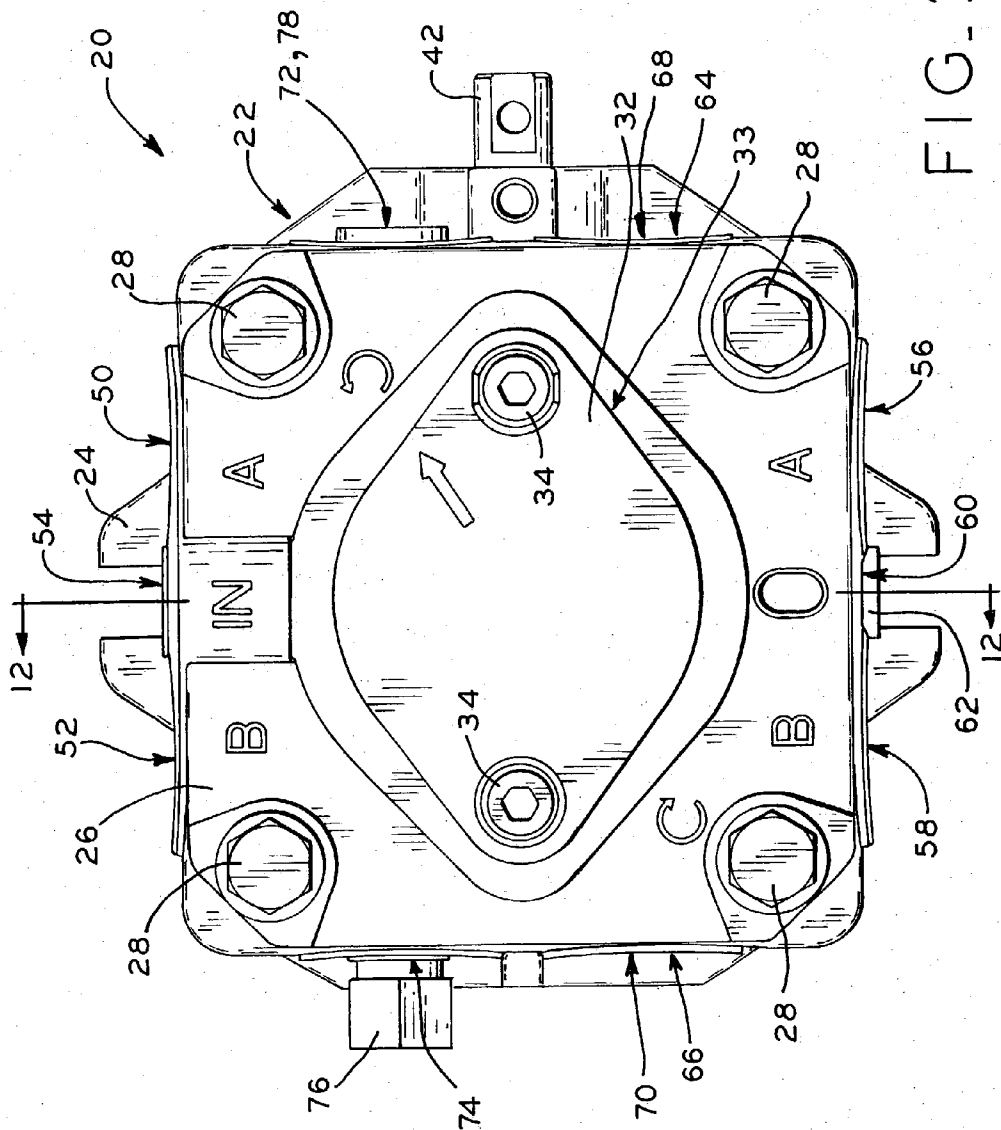

FIG. 11

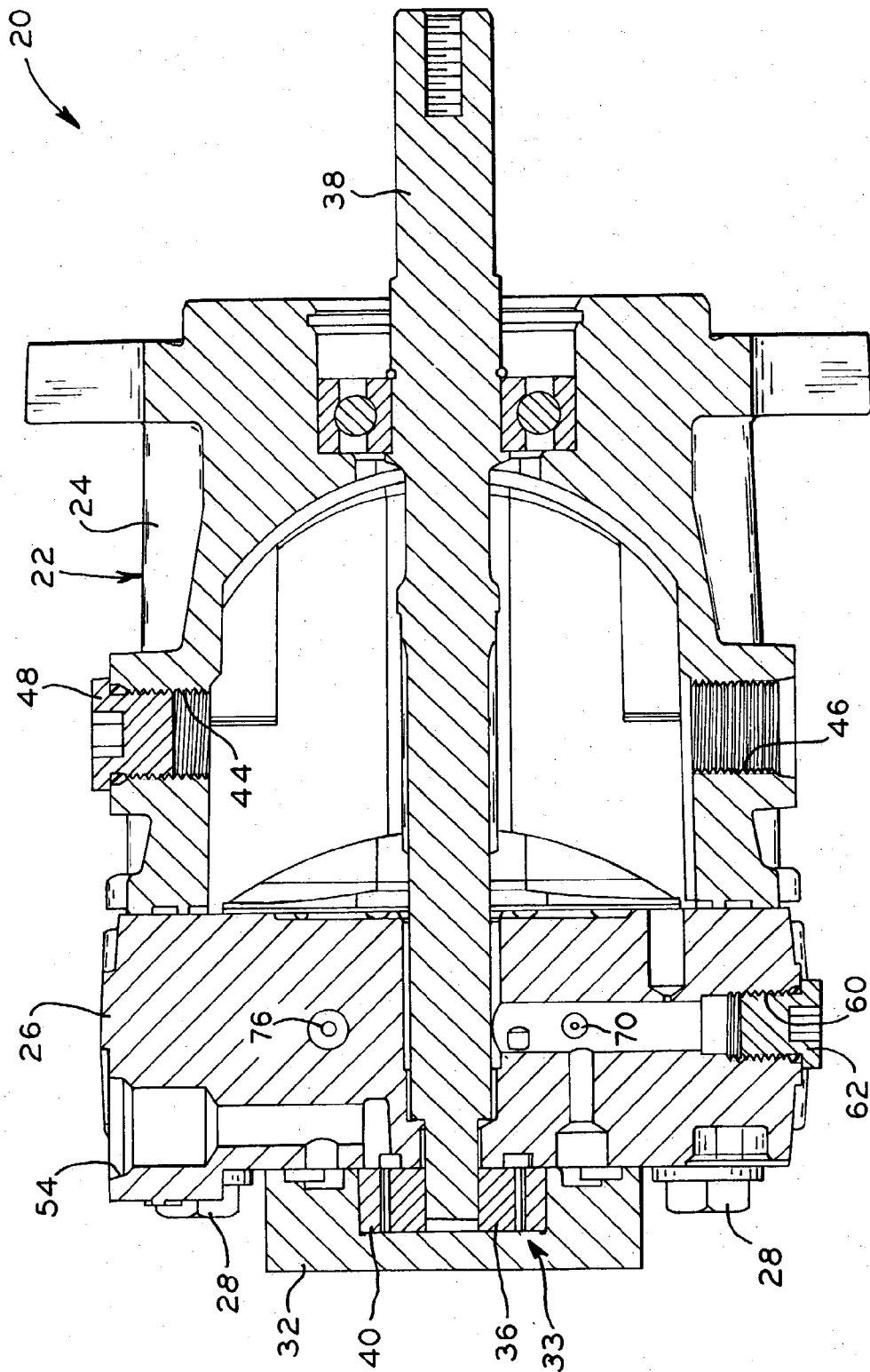

FIG. 12

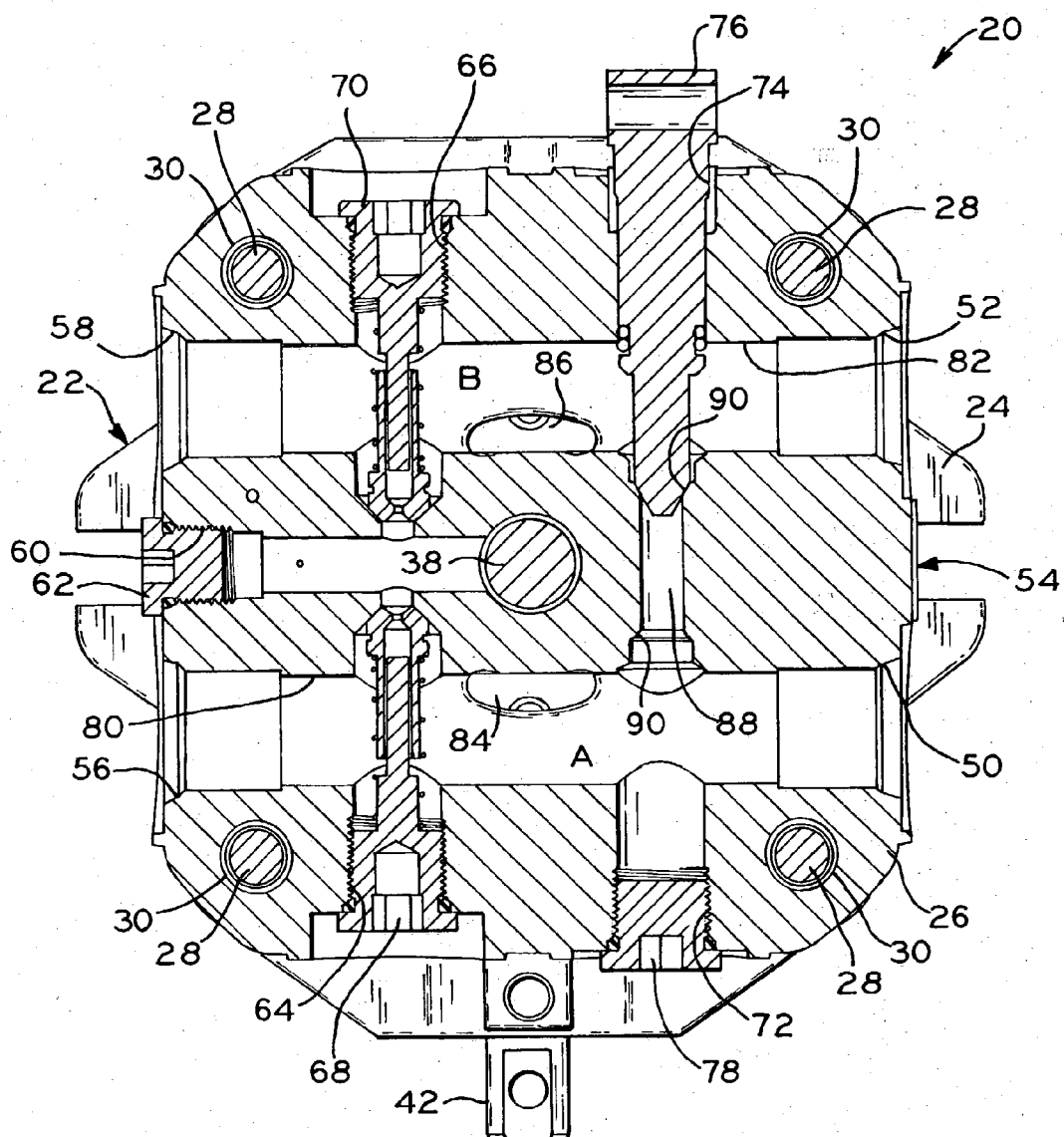
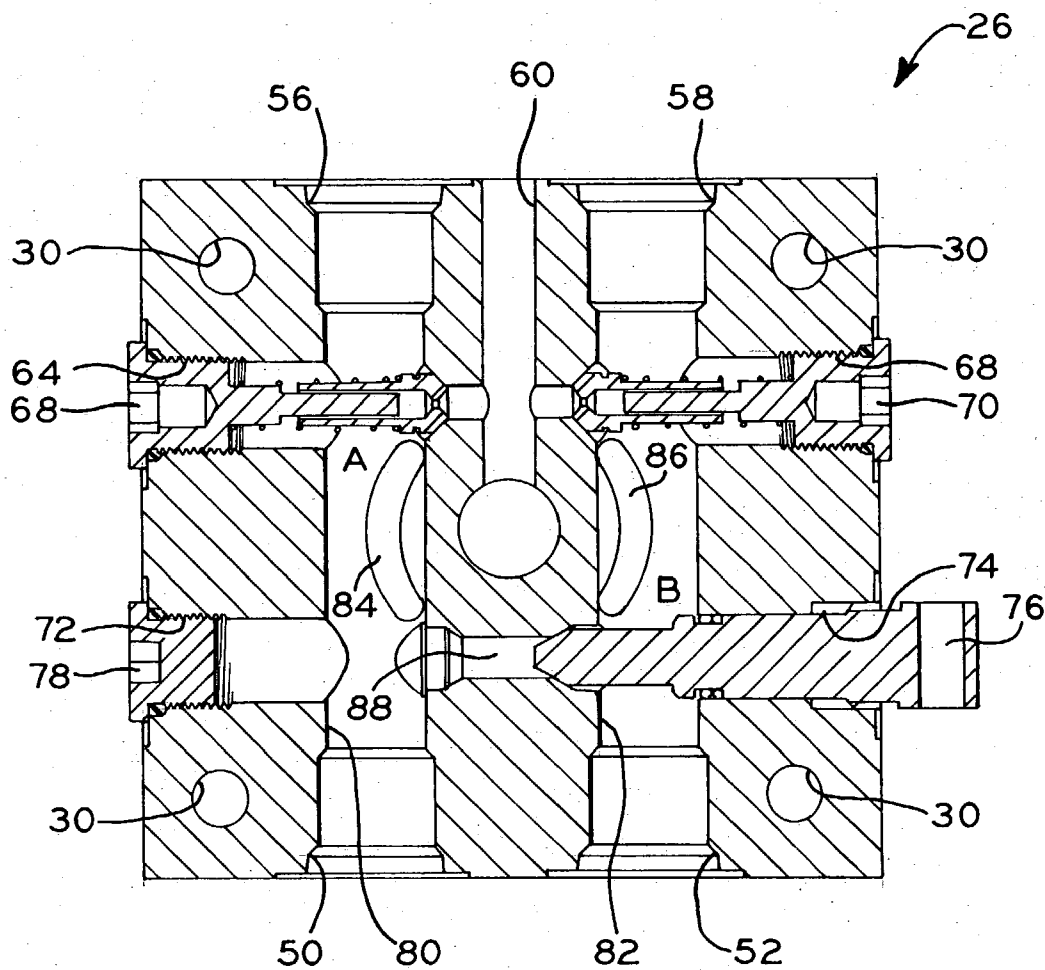

FIG. 13



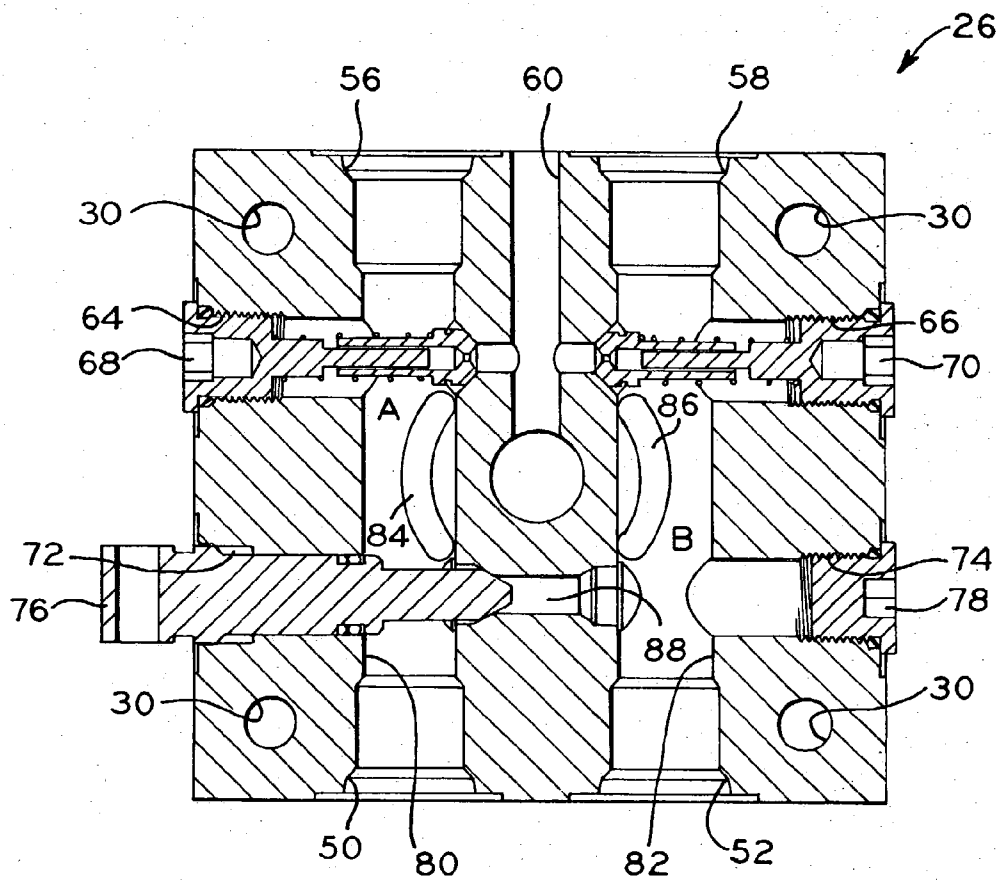

FIG. 15

HYDROSTATIC PUMP ASSEMBLY HAVING SYMMETRICAL ENDCAP

CROSS-REFERENCE TO RELATED APPLICATION

[0001] This application is related to and claims the benefit under 35 U.S.C. §119(e) of U.S. Provisional Patent Application Serial No. 60/392,401, entitled HDYROSTATIC PUMP ASSEMBLY HAVING SYMMETRICAL ENDCAP, filed Jun. 28, 2002.

BACKGROUND OF THE INVENTION

[0002] 1. Field of Invention

[0003] The present invention relates to hydrostatic transmissions such as used in the lawn and garden industry on self-propelled machines such as riding lawnmowers and wide area, walk-behind lawnmowers, and in other hydrostatic pump applications.

[0004] 2. Description of the Related Art

[0005] Hydrostatic pump assemblies are well-known in the art, and are commonly used for conversion of rotary motion into fluid motion. The pumped liquid, usually an incompressible liquid such as hydraulic oil, is normally received by and drives a motor which converts the fluid motion back into a rotary motion. A typical example of a hydraulic system comprising such a pump and motor is a hydrostatic transmission for driving the drive wheel(s) of a riding lawn mower. The pump may be rotatably driven via a belt and pulley arrangement by the engine, and is in fluid communication with the motor via hydraulic fluid lines. The output shaft of the motor is coupled to the drive wheel(s). Typically, the speed at which the pump is driven is constant and the pump is of variable displacement, i.e., the quantity and direction of fluid moved thereby through the hydraulic system, and thus the speed and direction at which the motor is driven, are varied by changing the pump displacement.

[0006] Notably, a single pump driven by the engine may be used to drive a single motor, the latter being coupled to drive wheels through a solid axle or differential assembly. Each of a pair of pumps driven by the engine may also be individually in fluid communication with one of a pair of motors, each motor respectively coupled to a single drive wheel as in a zero turn radius mower. Altering the displacements of the pumps individually controls the speed and direction of their respective motors.

[0007] Flexible packaging arrangements of separate pump and motor assemblies in a lawn mower are facilitated by their being operatively coupled through system fluid lines, rather than being rigidly connected to each other, which allow the pump and motor assemblies to be oriented in various positions, each individually attached to the mower frame. Pump assembly orientation is often dictated by the need to conveniently route the system fluid lines or to accommodate a simple linkage design for controlling pump displacement.

[0008] As is well-known, a pump's displacement control mechanism may include a pivotable swash plate internal to the pump housing and against which the pistons of the pump, which reciprocate in cylinders provided in a barrel driven by the pump's input shaft, bear. The angle of the

swash plate can be variably controlled via a rotatable control shaft or trunnion arm engaged with the swash plate and to which the linkage is connected. The swash plate is variably angled to adjust the stroke of the pistons, and thus the displacement of the pump.

[0009] Adjusting the swash plate angle such that the swash plate lies in a plane to which the pump's input shaft is substantially normal causes the pistons to have zero stroke. In this position, the transmission is in neutral, with no fluid flow being provided by the pump to the motor. Rotating the swash plate about its pivot axis from its neutral position in a particular direction forces the pump to direct fluid to the motor through one of the two system lines; rotating the swash plate about its pivot axis from its neutral position in the opposite direction forces the pump to direct fluid to the motor through the other of the two system lines. The direction of rotation of the motor is determined by which of the two system lines it receives high pressure fluid from the pump (the system supply line).

[0010] Typically, low pressure fluid is returned from the motor to the pump via the other of the two system lines (the system return line), wherein the fluid is again pumped by the pump's pistons through the system supply line to the motor for driving same. As noted above, the system supply and return lines are functionally interchangeable depending on which direction the swash plate is rotated about its pivot axis, the magnitude of the swash plate angle determining the speed at which the motor rotates in its forward or reverse direction.

[0011] Hydrostatic pump assemblies typically have a casing which includes a housing in which the pumping mechanism and displacement control means is located, and through which the swash plate control and input drive shafts extend. The casing also includes an endcap which is attached to the housing and which contains fluid passages and ports by which the fluid connections to the motor and an external, low pressure fluid reservoir are made.

[0012] The endcap also forms a valve body containing check valves through which make-up fluid may be received from a reservoir into the fluid system, and a bypass or dump valve by which the fluid conduits to and from the motor may be placed in direct communication, the fluid thus allowed to bypass the pumping mechanism, thereby allowing the lawnmower to be pushed and the motor(s) be back-driven without tending to also back-drive the pump(s). Typically, the endcap also contains a drain port through which fluid contained within the housing may be exhausted to the reservoir to prevent overpressurization of the housing.

[0013] Fluid pumped by the pump assembly is at a high pressure, perhaps about 2000 psig (13.8 MPa), and is directed by the system supply line to a fluid inlet of the motor. In some motor embodiments, the high pressure fluid received by the motor induces reciprocating movement of pistons within cylinders formed in a rotating barrel located within the housing of the motor, the barrel being rotatably fixed to the output shaft of the motor. The displacement of the motor is usually fixed, the pistons bearing against a nonpivotable swash plate located within the motor housing. Thus, with the exception of its having a fixed swash plate angle, the structure of the motor may be somewhat similar to that of the pump. It is also known for hydrostatic motors to have other configurations. For example, the motor may be of the gerotor type, also of fixed displacement.

[0014] Fluid having already effected rotating motion of the motor's output shaft is expelled from the motor via a return port, and is transported at relatively low pressure, perhaps about 40 psig (276 kPa), via the system return line to the fluid return port of the pump endcap, after which it is again received by the pumping mechanism, pressurized and pumped back to the motor. As noted above, the supply and return lines, and their respective pump and motor ports, are functionally interchanged in response to changes in the pump swash plate's being angled into a forward or reverse position relative to its neutral position. That is, in a forward swash plate position, one hydraulic line between a pump and its respective motor serves as the supply line, and in a reverse position, that same hydraulic line serves as the return line. Similarly, the second hydraulic line between that pump and motor conversely changes from a return line to a supply line.

[0015] An example of a known hydrostatic pump assembly is the Bantam Duty Pump (BDP) manufactured by Hydro-Gear of Sullivan, Ill., which is disclosed in U.S. Pat. No. 6,332,393 (hereinafter "Trimble '393"), the disclosure of which is expressly incorporated herein by reference. This pump assembly provides an endcap which may be assembled to the pump housing in one of two orientations, which are 180° apart about the axis of the pump's drive shaft, to provide a functionally "symmetric pump" permitting the trunnion arm to be placed on opposite sides of the pump. This pump assembly also provides two case drains in the endcap, through at least one of which fluid may be expelled from the housing to the reservoir. A bypass valve is positioned in the endcap in a hole located in a lateral side opposite that in which the system ports are located.

[0016] A shortcoming of the BDP pump of Trimble '393 is that to take advantage of its functional symmetry, the endcap must be disassembled from the housing, repositioned relative thereto, and reassembled. This process may be done (e.g., by OEM or service personnel) under conditions not within the pump manufacturer's control, and may result in pump failure or fluid leaks due to misassembly. Another shortcoming of the BDP pump of Trimble '393 is its lack of flexibility in bypass valve location if the pump is oriented in the vehicle based on system fluid line and linkage considerations, as is typical. Consequently, the bypass valve may not be easily accessible once the pump assembly is assembled into the vehicle.

[0017] A pump assembly which need not be substantially disassembled and reassembled to provide functional symmetry, perhaps by entities other than the pump manufacturer and by processes which are outside of the pump manufacturer's control, would better ensure pump and system quality and reliability, and would be a desirable improvement over the prior art.

[0018] Furthermore, a pump assembly having functional symmetry and which also provides flexibility regarding the location of its bypass valve, therefore affording possibly easier access to it once the pump has been installed in the vehicle, would also be a desirable advantage over the prior art.

SUMMARY OF THE INVENTION

[0019] The present invention overcomes the above mentioned shortcomings of previous hydrostatic pump assemblies, and provides desired improvements and advantages thereover.

[0020] The present invention provides the flexibility of locating the bypass valve and the individual system fluid lines in, e.g., either of two lateral sides of the endcap, and the casing drain in either of two lateral sides of the housing. In one form of the present invention, the bypass valve and the individual system fluid lines are located in either of two opposite lateral sides of the endcap and the casing drain is provided in either of two opposite lateral sides of the housing, thereby providing a functional symmetry which allows the inventive pump to be packaged in a vehicle more easily and which accommodates simpler fluid line routings and control linkage designs than previously achievable. Moreover, the present invention does so without requiring the endcap to be disassembled, reoriented and reassembled to the pump housing, thereby better assuring pump and system reliability.

[0021] The invention in one form thereof comprises an endcap for a hydrostatic pump. The endcap of this form of the present invention includes an endcap housing and a pair of system passages formed in the endcap housing and fluidly connected to the hydrostatic pump. Each of the pair of system passages spans a pair of system passage sides of the endcap housing.

[0022] The invention, in another form thereof, comprises an endcap for a hydrostatic pump. The endcap of this form of the present invention includes an endcap housing and system passage means for providing a pair of fluid accesses to the hydrostatic pump from a pair of system passage sides of the endcap housing.

[0023] The invention, in yet another form thereof, comprises an endcap for a hydrostatic pump. The endcap of this form of the present invention includes an endcap housing having a pair of system passages formed therein. Each of the system passages is fluidly connected to the hydrostatic pump. The endcap of this form of the present invention further includes a bypass passage fluidly connecting a pair of system passages. The bypass passage includes a first end and a second end each of which forms a valve seat.

[0024] In another form thereof, the present invention provides a hydrostatic pump assembly having a casing which encloses a pumping mechanism, and including a housing, and an endcap attached to the housing. The endcap has at least one lateral exterior surface, and a first system fluid passage having a pair of system ports located opposite each other in the endcap lateral exterior surface, and a second system fluid passage having a pair of system ports located opposite each other in the endcap lateral exterior surface, each of the first and second system fluid passages being in fluid communication with the pumping mechanism.

[0025] In yet another form thereof, the present invention provides a hydrostatic pump assembly having an endcap provided with a bypass passage extending between first and second system fluid passages, the bypass passage being in communication with a pair of bypass valve holes located, e.g., opposite each other in the endcap's lateral exterior surface. A bypass valve is located in one of, and is inter-

changeable between, the pair of bypass valve holes, and a removable plug is located in the other of the bypass valve holes. The bypass passage is selectively opened and closed by the bypass valve, whereby the first and second system fluid passages may be placed in and out of direct fluid communication with each other through the bypass passage.

[0026] The present invention also provides a hydrostatic pump assembly provided with a pair of selectively closeable case drains located opposite each other in its housing.

[0027] The inventive pump assembly thereby provides functional symmetry by which flexibility of pump orientation and hydrostatic fluid lines is improved vis-à-vis previous hydraulic pump assemblies. Furthermore, in accordance with the present invention, functional symmetry is provided without necessitating that the pump assembly be substantially disassembled and reassembled by entities and processes beyond the control of the pump manufacturer, thereby promoting pump and system reliability.

BRIEF DESCRIPTION OF THE DRAWINGS

[0028] The above mentioned and other features and objects of this invention, and the manner of attaining them, will become more apparent and the invention itself will be better understood by reference to the following description of an embodiment of the invention taken in conjunction with the accompanying drawings, wherein:

[0029] FIG. 1 is a perspective view of the inventive pump assembly;

[0030] FIG. 2 is a perspective view of the inventive pump assembly;

[0031] FIG. 3 is an enlarged cutaway view of the inventive pump assembly, showing a portion of its endcap interior;

[0032] FIG. 4 is a partial, enlarged cutaway view of the inventive pump assembly, showing a portion of its endcap interior;

[0033] FIG. 5 is a partial, enlarged cutaway view of the inventive pump assembly, showing portions of the endcap and housing interiors, excluding the pumping mechanism within the housing;

[0034] FIG. 6 is a partial, enlarged cutaway view of the inventive pump assembly, showing portions of the endcap and housing interiors, excluding the pumping mechanism within the housing;

[0035] FIG. 7 is a first side view of the inventive pump assembly;

[0036] FIG. 8 is a second side view of the inventive pump assembly, showing a first pair of system ports and a first housing drain port;

[0037] FIG. 9 is a third side view of the inventive pump assembly;

[0038] FIG. 10 is a fourth side view of the inventive pump assembly, showing a second pair of system ports and second housing drain port;

[0039] FIG. 11 is a rear view of the inventive pump assembly as seen from line 11-11 of FIG. 9;

[0040] FIG. 12 is a sectional view of the inventive pump assembly along line 12-12 of FIG. 11, excluding the pumping mechanism within the housing;

[0041] FIG. 13 is a sectional view of the inventive pump assembly along line 13-13 of FIG. 8

[0042] FIG. 14 is a sectional view of the endcap of the inventive pump assembly showing the bypass or dump valve in a first orientation; and

[0043] FIG. 15 is a sectional view of the endcap of FIG. 14 showing the bypass or dump valve in a second orientation.

[0044] Corresponding reference characters indicate corresponding parts throughout the several views. Although the drawings represent one embodiment of the present invention, the drawings are not necessarily to scale and certain features may be exaggerated in order to better illustrate and explain the present invention. The exemplification set out herein illustrates a particular embodiment of the invention such exemplification is not to be construed as limiting the scope of the invention in any manner.

DETAILED DESCRIPTION OF THE INVENTION

[0045] Pump assembly 20 includes casing 22 comprised of housing 24 and endcap 26. Disposed within housing 24 is a pumping mechanism including a rotating cylinder block within which are provided a plurality of circumferentially distributed cylinders, each having spring-loaded, reciprocating pistons positioned therein. The displacement of the pump assembly is varied by altering the stroke of these pistons through means of pivoting a swash plate against which one end of the pistons bear through a thrust bearing. Endcap 26 is attached to housing 24 by bolts 28 which extend through bolt holes 30 (see, e.g., FIGS. 3 and 4) provided in the four corners of endcap 26. Endcap 26 has the general shape of a parallelepiped having an exterior surface comprised of four connected lateral sides, and two opposite end faces, one of which is an exterior endface located opposite the housing, the other of which is an interior endface located inside the housing. The end face located inside the housing has a planar surface thereon against which the rotating cylinder block slidably abuts, this surface being provided with a pair of arcuate openings through which fluid is received into or discharged by the pumping mechanism.

[0046] Attached to the exterior face of endcap 26 is cover 32 for charge pump 33 (see, e.g., FIG. 3). Cover 32 is attached to endcap 26 by means of bolts 34 as shown, e.g., in FIG. 11. Referring to FIG. 3, charge pump 33 includes gerotor impeller 36 located within cover 32 and rotatably coupled to pump drive shaft 38. Shaft 38 extends through housing 24, the rotating cylinder block of the pumping mechanism therein, and endcap 26. Charge pump 33 also includes gerotor follower 40 rotatably supported by cover 32 and which is drivingly enmeshed with impeller 36. Charge pump 33 pumps makeup fluid from a reservoir (not shown) external to pump assembly 20 to the hydrostatic system, as described further herein below.

[0047] Extending laterally through the side of housing 24 is swash plate angle control shaft or trunnion arm 42, which is rotatably manipulated through a linkage (not shown) by an

operator for altering the displacement of the pumping mechanism within housing 24 as discussed above. Also provided on the lateral sides of housing 24 are case drains 44 (FIG. 1) and 46 (FIG. 2), either of which may be sealed with threaded plug 48, the other of which is provided with a fitting (not shown) for a conduit through which hydraulic fluid expelled through the case drain may be directed to the fluid reservoir.

[0048] Endcap 26 is assembled to the housing in a single, common orientation at the pump manufacturer's assembly facility, and need not be later disassembled from, reoriented, and reassembled to the housing to realize the functional symmetry of pump assembly 20. Thus pump and system reliability is better assured. Further, the inventive pump may be provided to an OEM or service provider under a single part number, thereby simplifying inventorying and other administrative functions associated with vehicle manufacturing or servicing.

[0049] One lateral side of endcap 26 is provided with system port 50 for circuit side A and system port 52 for circuit side B, circuit sides A and B alternately serving as the supply and return circuits for the hydrostatic system depending on whether the swash plate is adjusted to its forward or reverse position. Disposed between ports 50 and 52 is oil supply port 54 which is provided with a fitting (not shown) for a conduit through which oil is received from the reservoir and supplied to the hydrostatic system through check valves, as described further below.

[0050] On the opposite lateral side of endcap 26 are also located system port 56 for circuit side A, and system port 58 for circuit side B. Notably, system ports 50 and 56 for circuit side A are in direct communication with each other and are located at opposite ends of a bore extending through endcap 26. Similarly, system ports 52 and 58 for circuit side B are also aligned with each other at opposite ends of a bore extending through endcap 26. Disposed between system port 56 and system port 58 is makeup fluid bore 60 which extends laterally into endcap 26 and is plugged with threaded plug 62.

[0051] In the lateral sides adjacent the sides in which the system ports are located in endcap 26 are check valve holes 64 and 66 which are axially aligned with one another, and within which are respectively disposed check valve assemblies 68 and 70. As illustrated in FIG. 4, check valve assemblies 68 and 70 are biased by springs into a closed position which prevents fluid from either circuit side A or B from entering bore 60. Makeup fluid pumped by charge pump 33 is forced into bore 60, and acts against check valves 68 and 70. When the pressure of the fluid in bore 60 exceeds the fluid pressure in either circuit side A or B by a predetermined amount, the respective check valve is moved off of its seat and makeup fluid flows from bore 60 to that circuit side, as is known in the art.

[0052] Adjacent check valve holes 64 and 66 in the respective lateral sides of endcap 26 are located bypass valve holes 72 and 74. As shown, these bypass valve holes are also axially aligned, and one is provided with bypass valve 76. The other bypass valve hole is sealed with threaded plug 78. As discussed further herein below, OEM or service personal may simply interchange bypass valve 76 and plug 78 as necessary to afford easy access to the bypass valve when pump assembly 20 is installed in the vehicle.

[0053] With reference to FIGS. 4 and 13-15, it can be seen that system ports 50 and 56 are located at opposite ends of A-side system passage 80, and system ports 52 and 58 are located at opposite ends of B-side system passage 82. Located substantially centrally along system passage 80 is pump passage 84 which extends toward the surface of endcap 26 against which the cylinder block slidably abuts, pump passage 84 opening into one of the two above-mentioned arcuate openings through which fluid is received or expelled from the cylinders of the cylinder block. Similarly, located substantially centrally along system passage 82 is pump passage 86 which is in communication with the other arcuate passage in the cylinder-abutting surface of the endcap.

[0054] A-side and B-side system passages 80 and 82 are in selective fluid communication with each other through bypass passage 88, which is provided with seats 90 at its opposite ends, one of seats 90 interfacing with the tip of bypass valve 76 to close communication between system passages 80 and 82. When bypass valve 76 is disengaged from seat 90, system passages 80 and 82 are placed in fluid communication via bypass passage 88. Fluid being pumped into one of system passages 80 and 82 by, for example, a back-driven hydrostatic system motor, will then be directed through bypass passage 88 to the other system passage, thereby allowing that fluid to bypass the pumping mechanism. By so providing direct fluid communication between the A-side and B-side system passages, fluid will not be forced into pump passages 84 or 86 which would tend to back-drive pump assembly 20. As noted above, the pump input shaft may be in constant engagement with the engine output shaft through a belt drive, which would inhibit reverse rotation of the pump. Disengagement of bypass valve 76 from its seat 90 thus allows the vehicle to be easily pushed.

[0055] Hydrostatic fluid supply and return lines between pump assembly 20 and its associated motor may be fitted into either of ports 50 and 56 for the A-side circuit, and likewise into either of ports 52 and 58 for the B-side circuit. The A-side and B-side system ports which are not being used for conveyance of fluid to and from pump assembly 20 may be sealed with threaded plugs (not shown). In this manner, simplicity of system line and control linkage packaging is accommodated.

[0056] By providing the flexibility of locating the bypass valve and the individual A and B-side system lines in either of two opposite lateral sides of the endcap, and the casing drain in either lateral side of the housing, inventive pump assembly 20 provides a functional symmetry which allows the inventive pump to be packaged in a vehicle more easily and which accommodates simpler fluid line routings and control linkage designs than previously achievable. Moreover, the present invention does so without requiring the endcap to be disassembled, reoriented and reassembled to the pump housing, thereby better assuring pump and system reliability.

[0057] While this invention has been described as having an exemplary design, the present invention may be further modified within the spirit and scope of this disclosure. This application is therefore intended to cover any variations, uses, or adaptations of the invention using its general principles. Further, this application is intended to cover such

departures from the present disclosure as come within known or customary practice in the art to which this invention pertains.

What is claimed is:

1. An endcap for a hydrostatic pump, comprising:
 - an endcap housing; and
 - a pair of system passages formed in said endcap housing, each said system passage fluidly connected to the hydrostatic pump, each said system passage fluidly connected to a pair of system ports formed in an exterior of said endcap housing.
2. The endcap of claim 1, further comprising:
 - a bypass passage fluidly connecting said pair of system passages, said bypass passage having a first end and a second end, each of said first and said second ends forming a valve seat.
3. The endcap of claim 2, further comprising:
 - a pair of bypass valve holes formed in said exterior of said endcap housing, each of said pair of bypass valve holes providing access to one of said valve seats.
4. The endcap of claim 3, wherein said pair of bypass valve holes are formed in a pair of opposing bypass passage sides of said endcap housing, and each said pair of system ports are formed in opposing system passage sides of said endcap housing.
5. The endcap of claim 3, wherein each said bypass valve hole is aligned with one of said valve seats.
6. The endcap of claim 3, further comprising:
 - a bypass valve seated on one of said valve seats, whereby said pair of system passages are no longer fluidly connected, said bypass valve positioned in one of said bypass valve holes and secured to said endcap housing.
7. An endcap for a hydrostatic pump, comprising:
 - an endcap housing; and
 - system passage means for providing a pair of fluid accesses to the hydrostatic pump from a pair of system passage sides of said endcap housing.
8. The endcap of claim 1, further comprising:
 - a bypass passage fluidly connecting said pair of fluid accesses, said bypass passage having a first end and a second end, each of said first and said second ends forming a valve seat.
9. The endcap of claim 8, further comprising:
 - a pair of bypass valve holes formed in a pair of opposing bypass passage sides of said endcap housing, each of said pair of bypass valve holes providing access to one of said valve seats.
10. The endcap of claim 8, wherein said bypass passage sides comprise opposing sides of said endcap housing and said system passage sides comprise opposing sides of said endcap housing.
11. The endcap of claim 9, wherein each said bypass valve hole is aligned with one of said valve seats.
12. The endcap of claim 8, further comprising:
 - a bypass valve seated on one of said valve seats, whereby said pair of system passages are no longer fluidly

- connected, said bypass valve positioned in one of said bypass valve holes and secured to said endcap housing.
13. An endcap for a hydrostatic pump, comprising:
 - an endcap housing;
 - a pair of system passages formed in said endcap housing, each said system passage fluidly connected to the hydrostatic pump; and
 - a bypass passage fluidly connecting said pair of system passages, said bypass passage having a first end and a second end, each of said first and said second ends forming a valve seat.
 14. The endcap of claim 13, further comprising:
 - a pair of bypass valve holes formed in a pair of opposing bypass passage sides of said endcap housing, each of said pair of bypass valve holes providing access to one of said valve seats.
 15. The endcap of claim 14, wherein each said bypass valve hole is aligned with one of said valve seats.
 16. The endcap of claim 14, further comprising:
 - a bypass valve seated on one of said valve seats, whereby said pair of system passages are no longer fluidly connected, said bypass valve positioned in one of said bypass valve holes and secured to said endcap housing.
 17. A hydrostatic pump assembly comprising:
 - a casing;
 - a pumping mechanism, said casing enclosing said pumping mechanism, said casing comprising:
 - a housing; and
 - an endcap attached to said housing, said endcap having at least one lateral exterior surface, and a first system fluid passage having a pair of system ports located opposite each other in said endcap lateral exterior surface, and a second system fluid passage having a pair of system ports located opposite each other in said endcap lateral exterior surface, said first and second system fluid passages in fluid communication with said pumping mechanism.
 18. The hydrostatic pump assembly of claim 17, wherein said endcap lateral exterior surface is formed by four connected lateral sides, opposing said system ports of each said pair of system ports being located in opposite ones of said four lateral sides.
 19. The hydrostatic pump assembly of claim 17, wherein one said system port of each said pair of system ports is selectively plugged.
 20. The hydrostatic pump assembly of claim 17, wherein said endcap has a bypass passage extending between said first and said second system fluid passages, said bypass passage in communication with a pair of bypass valve holes located opposite each other in said endcap lateral exterior surface, said hydrostatic pump assembly further comprising:
 - a bypass valve located in one of said pair of bypass valve holes, said bypass valve interchangeable between said pair of bypass holes; and

a removable plug located in the other of said pair of bypass valve holes, said bypass passage being selectively opened and closed by said bypass valve, whereby said first and said second system fluid passages may be placed in and out of direct fluid communication with each other through said bypass passage.

21. The hydrostatic pump assembly of claim 17, wherein said pump assembly is provided with a pair of selectively closeable case drains located opposite each other in said housing,

* * * * *