

(19) World Intellectual Property Organization
International Bureau



(43) International Publication Date
9 March 2006 (09.03.2006)

PCT

(10) International Publication Number
WO 2006/026664 A1

- (51) International Patent Classification:
G02B 6/036 (2006.01) G02B 6/44 (2006.01)
- (21) International Application Number:
PCT/US2005/030964
- (22) International Filing Date: 31 August 2005 (31.08.2005)
- (25) Filing Language: English
- (26) Publication Language: English
- (30) Priority Data:
10/930,575 31 August 2004 (31.08.2004) US
11/196,185 3 August 2005 (03.08.2005) US
- (71) Applicant (for all designated States except US): 3M INNOVATIVE PROPERTIES COMPANY [US/US]; 3M Center, Post Office Box 33427, Saint Paul, MN 55133-3427 (US).
- (72) Inventors: VARNER, Wayne, F.; 3M Center, Post Office Box 33427, Saint Paul, MN 55133-3427 (US). SYKORA, Craig, R.; 3M Center, Post Office Box 33427, Saint Paul, MN 55133-3427 (US). WU, Junjun; 3M Center, Post Office Box 33427, Saint Paul, MN 55133-3427 (US).
- (74) Agent: ROSENBLATT, Gregg, H.; 3M Center, Office of Intellectual Property Counsel, Post Office Box 33427, Saint Paul, MN 55133-3427, (US).
- (81) Designated States (unless otherwise indicated, for every kind of national protection available): AE, AG, AL, AM,

AT, AU, AZ, BA, BB, BG, BR, BW, BY, BZ, CA, CH, CN, CO, CR, CU, CZ, DE, DK, DM, DZ, EC, EE, EG, ES, FI, GB, GD, GE, GH, GM, HR, HU, ID, IL, IN, IS, JP, KE, KG, KM, KP, KR, KZ, LC, LK, LR, LS, LT, LU, LV, MA, MD, MG, MK, MN, MW, MX, MZ, NA, NG, NI, NO, NZ, OM, PG, PH, PL, PT, RO, RU, SC, SD, SE, SG, SK, SL, SM, SY, TJ, TM, TN, TR, TT, TZ, UA, UG, US, UZ, VC, VN, YU, ZA, ZM, ZW.

(84) Designated States (unless otherwise indicated, for every kind of regional protection available): ARIPO (BW, GH, GM, KE, LS, MW, MZ, NA, SD, SL, SZ, TZ, UG, ZM, ZW), Eurasian (AM, AZ, BY, KG, KZ, MD, RU, TJ, TM), European (AT, BE, BG, CH, CY, CZ, DE, DK, EE, ES, FI, FR, GB, GR, HU, IE, IS, IT, LT, LU, LV, MC, NL, PL, PT, RO, SE, SI, SK, TR), OAPI (BF, BJ, CF, CG, CI, CM, GA, GN, GQ, GW, ML, MR, NE, SN, TD, TG).

Declarations under Rule 4.17:

— as to applicant's entitlement to apply for and be granted a patent (Rule 4.17(ii)) for the following designations AE, AG, AL, AM, AT, AU, AZ, BA, BB, BG, BR, BW, BY, BZ, CA, CH, CN, CO, CR, CU, CZ, DE, DK, DM, DZ, EC, EE, EG, ES, FI, GB, GD, GE, GH, GM, HR, HU, ID, IL, IN, IS, JP, KE, KG, KM, KP, KR, KZ, LC, LK, LR, LS, LT, LU, LV, MA, MD, MG, MK, MN, MW, MX, MZ, NA, NG, NI, NO, NZ, OM, PG, PH, PL, PT, RO, RU, SC, SD, SE, SG, SK, SL, SM, SY, TJ, TM, TN, TR, TT, TZ, UA, UG, UZ, VC, VN, YU, ZA, ZM, ZW, ARIPO patent (BW, GH, GM, KE, LS, MW, MZ, NA, SD, SL, SZ, TZ, UG, ZM, ZW), Eurasian patent (AM, AZ, BY, KG, KZ, MD, RU, TJ, TM), European patent (AT, BE, BG, CH, CY, CZ, DE, DK, EE, ES, FI, FR, GB, GR, HU, IE, IS, IT, LT, LU, LV, MC, NL, PL, PT, RO,

[Continued on next page]

(54) Title: TRIPLE-BAND BEND TOLERANT OPTICAL WAVEGUIDE

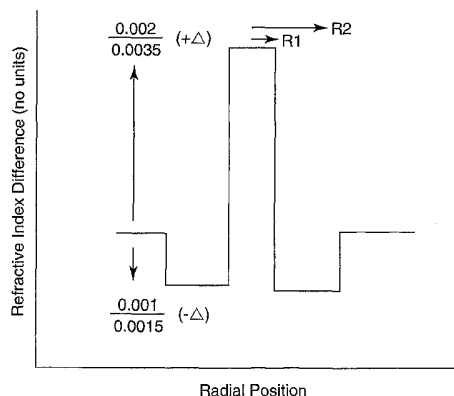

(57) Abstract: An optical waveguide comprises a core, an inner cladding laterally surrounding the core, and an outer cladding laterally surrounding the inner cladding, wherein the core, inner cladding, and outer cladding have a depressed well configuration. The waveguide operates in three or more wavelength bands, wherein a first wavelength band is centered at about 1300 nm, and wherein a second wavelength band is centered at about 1625 nm. The waveguide can have bend losses that are less than or equal to 0.7 dB/turn when measured over a 10 mm radius bend at 1625 nm. The waveguide can also have bend losses that are less than or equal to 1.0 dB/turn when measured on a 5 mm radius bend at 1625 nm and bend losses that are less than or equal to 1.5 dB/turn when measured on a 5 mm radius bend at 1650 nm.

WO 2006/026664 A1



- SE, SI, SK, TR), OAPI patent (BF, BJ, CF, CG, CI, CM, GA, GN, GQ, GW, ML, MR, NE, SN, TD, TG)*
- *as to the applicant's entitlement to claim the priority of the earlier application (Rule 4.17(iii)) for all designations*
 - *as to the applicant's entitlement to claim the priority of the earlier application (Rule 4.17(iii)) for all designations*

Published:

- *with international search report*

- *before the expiration of the time limit for amending the claims and to be republished in the event of receipt of amendments*

For two-letter codes and other abbreviations, refer to the "Guidance Notes on Codes and Abbreviations" appearing at the beginning of each regular issue of the PCT Gazette.

Triple-Band Bend Tolerant Optical Waveguide

FIELD OF THE INVENTION

The present invention relates to an optical waveguide operating in the 1300 – 1650 nm window. In particular, the present invention relates to a depressed well optical fiber having a triple wavelength band design that is able to operate in tight bend environments with minimal bend induced losses. Further, the optical fiber can have a mode field diameter (MFD) that closely matches large mode field diameter fibers such as common long haul telecommunications fibers.

BACKGROUND OF THE INVENTION

Optical fibers form some of the main lines through which telecommunications data is connected all over the world. An optical fiber typically includes a core region surrounded concentrically by a cladding. Some fiber designs, known as “double cladding” designs, surround the core region with an inner cladding, which is in turn surrounded by an outer cladding. The outer cladding likewise is surrounded by an external medium.

The parameters in such double cladding waveguide designs usually are:

Dependent parameters

MFD operational mode field diameter
 λ operational wavelength
 λ_c second mode cutoff wavelength

Independent parameters

r_{co} core radius generated from a single effective (refractive index) step approximation of the core region
 r_{ic} inner cladding radius
 W inner cladding width ($r_{ic} - r_{co}$) generated from a single effective step approximation of the inner cladding region
 r_{oc} outer cladding radius
 n_{co} core refractive index generated from a single effective step approximation of the core region
 n_{ic} inner cladding refractive index generated from a single step approximation of the inner cladding region

$$\begin{aligned}
 n_{oc} & \text{ outer cladding refractive index} \\
 n_{ext} & \text{ external medium refractive index} \\
 +\Delta & = (n_{co} - n_{oc})/n_{oc} \\
 -\Delta & = (n_{ic} - n_{oc})/n_{oc} \\
 5 \quad \Delta_{Tot} & = |(+\Delta)| + |(-\Delta)|
 \end{aligned}$$

Early large-scale commercial systems were designed to operate at an operational wavelength λ of about 1300 nm, a region of relatively low optical absorption loss and very low chromatic dispersion for silica fibers. In addition, intrinsic optical absorption losses in silica fibers were known to be even lower at 1550 nm.

Fiber suppliers began making telecommunications optical fibers that could operate at either 1300 nm or 1550 nm, such as Corning SMF-28™ single mode fiber. This fiber has a typical core diameter of 8.2 micrometers and a MFD of about 9-10 microns in the window from 1300 nm to 1550 nm. This fiber is known as a “matched clad” design with an effective step index core having a (normalized or relative) core refractive index above the outer cladding ($+\Delta = (n_{co} - n_{oc})/n_{oc}$) of about 0.0035.

Early fiber optic telecommunication systems involved “long haul” applications from one telephone company central office to another. Long haul telecommunications fibers are typically kept relatively straight in large multi-fiber cables, and are thus protected from bending losses of light due to exceeding the critical bend radius of the fiber design (typically in the range of 25 mm to 12.5 mm).

A recent trend had been to extend fiber optics outward from the central offices, providing “fiber to the campus” and “fiber to the desktop” in commercial buildings, and “fiber to the neighborhood” and eventually “fiber to the home” in residential areas, sometimes referred to as “Fiber-To-The-X,” or “FTTX.” One conventional example for premises applications is the Volition™ VF-45 fiber optic connector and premise “wiring” system, manufactured by 3M Company, of St. Paul, MN, as shown in several patents, including US 5,757,997.

To minimize optical losses in connectors such as these, the optical fibers are designed to operate at the same wavelength and have approximately the same mode field diameter (MFD) at that wavelength. For such connectors, it is not practical to adjust the MFD of the two fiber ends (for duplex applications) by high temperature diffusion of core

dopants, as can be done when fusion splicing two optical fibers for long haul cables (see, e.g., EP 1094346 A1).

As a light signal travels in an optical fiber the signal is attenuated, due to both material effects and waveguide effects. Waveguide effects include two categories of optical bending loss, microbending and macrobending losses. Macrobending loss occurs when a length of fiber is bent into a curve such that some light is radiated out of the core into the cladding of the fiber and lost. Microbending losses result from concentrated pressure or stresses exerted on the surface of the fiber. Microbending loss occurs when the fiber is exposed to localized pressures and stress points as, for example, if the fiber is pressed against a rough textured surface (such as sandpaper). When the outer surface of the fiber is pressed against the raised points, a coating that is too hard may transfer these stresses to the core, causing scattering losses. Microbend losses are usually negligible for short lengths of fiber.

Such stresses may be reduced by providing a relatively soft, low-modulus inner coating on the surface of the glass fiber. However, usually such coatings are removed from the fiber end in order to accurately align a single mode fiber with another fiber in a connector. The stripped fiber ends are then susceptible to breakage from abrasion and moisture.

A solution to this problem is a fiber having a glass core, glass cladding, polymer cladding construction (referred to herein as a "GGP" fiber), as described in US patent RE 36,146, which is hereby incorporated by reference. The RE 36,146 patent describes several polymer coatings and other coating materials that can be used in manufacturing GGP fibers. Other polymer coatings and/or coating materials are described in US Patent No. 6,895,156; US Patent No. 6,587,628; US Patent No. 5,644,670; and US Patent No. 6,269,210 (all of which are hereby incorporated by reference).

These polymer coatings typically have a Shore D hardness of about 55 or more, or a Young's Modulus of from 50 kg/mm² to 250 kg/mm² at room temperature, and these coatings can adhere tightly to the outermost glass surface of the optical fiber. They are exemplarily applied to an optical fiber such that their outer surface is sufficiently concentric with the core of the optical fiber that when a GGP fiber is placed in a typical fiber optic mechanical connector and optically connected to a second fiber, the optical loss is not significantly greater than for a similar connection using an uncoated fiber having the same outer diameter as the GGP optical fiber.

In addition, the glass portion of the GGP fiber can be smaller than the standard 125 micrometer outside diameter, and an adherent, very concentric, and relatively hard polymer layer (coating) is added to bring the fiber diameter up to the standard 125 micrometer diameter while maintaining concentricity for connectorization. The
5 construction is cabled within a low-modulus coating to minimize microbending losses, but when the low modulus coating is stripped off for connectorization the outer glass surface of the fiber is not exposed or damaged.

Among the optical fiber applications with the most severe bending loss requirements have been the fiber optic guided missile (FOG-M) and tethered weapons
10 applications for the military. Designs for fibers used in tethered weapon applications have concentrated on keeping the light signals very tightly confined in the fiber core, by designing fibers with small MFD (~4-7 micrometers at 1550 nm). Some designs include a depressed refractive index well around the core (so called "W" fibers) that provide for a broader range of operating wavelengths. The high matched clad index design may also
15 provide reasonable bend tolerance if designed to operate at a single wavelength. Examples of depressed well, small MFD fibers are described in US Patent Nos. 4,838,643 and 5,032,001.

Although these fibers provide low bend loss, their small MFDs make them unsuitable for connectorization to the low cost, large (> 8.0 microns) MFD telecom fibers.
20 Multi-wavelength versions of these fibers have the smallest MFDs and therefore the largest MFD mismatches and associated connector losses making them impractical for premise applications. These fibers can only be fusion spliced or thermally treated to eliminate the MFD mismatch, which are not practical procedures for the multiple plug-in/disconnect applications.

25 In general, fiber designs with smaller MFDs have a higher numerical aperture (NA) at a given wavelength, since both parameters indicate a more tightly confined optical mode, which will be less affected by macrobending or other external influences. The relationship between MFD, macrobending loss, and second mode cutoff wavelength is discussed in US Patent Nos. 5,608,832 and 5,278,931, and references therein. Further
30 discussion of the relationship between MFD, macrobending loss, and second mode cutoff wavelength is discussed in US Patent No. 6,895,156 (incorporated by reference herein in its entirety).

SUMMARY

According to one aspect of the present invention, an optical fiber comprises a core, an inner cladding laterally surrounding the core, and an outer cladding laterally surrounding the inner cladding, wherein the core, inner cladding, and outer cladding have a depressed well configuration. The fiber operates in three or more wavelength bands, wherein a first wavelength band is centered at about 1300 nm and a second wavelength band is centered at about 1625 nm. In addition, the fiber has bend losses that are less than or equal to 0.7 dB/turn when measured on a 10 mm radius bend at 1625 nm. A third operating wavelength band for the fiber can be centered at about 1550 nm.

According to another aspect of the present invention, an optical fiber comprises a core, an inner cladding laterally surrounding the core, and an outer cladding laterally surrounding the inner cladding, wherein the core, inner cladding, and outer cladding have a depressed well configuration. The fiber operates in three or more wavelength bands, wherein a first wavelength band is centered at about 1300 nm and a second wavelength band is centered at about 1625 nm. In addition, the fiber has bend losses that are less than or equal to 1.0 dB/turn when measured on a 5 mm radius bend at 1625 nm and bend losses that are less than or equal to 1.5 dB/turn when measured on a 5 mm radius bend at 1650 nm. A third operating wavelength band for the fiber can be centered at about 1550 nm.

According to another aspect of the present invention, an optical waveguide includes a core having a refractive index n_{co} and a radius r_{co} , an inner cladding laterally surrounding the core, the inner cladding having a refractive index n_{ic} and an outer radius of r_{ic} , and an outer cladding laterally surrounding the inner cladding, the outer cladding having a refractive index n_{oc} . The core, inner cladding, and outer cladding have a narrow depressed well configuration, wherein $n_{co} > n_{oc} > n_{ic}$. The range of the ratio of the inner, depressed-well clad radius, r_{ic} , to core radius, r_{co} , varies from about 3.0 to 5.0, and in some aspects the ratio is greater than or equal to about 3.6. The waveguide has a $+\Delta$ of about 0.0030 to 0.0036, a $-\Delta$ of about -0.0018 to -0.0012, and a Δ_{Tot} of about 0.0048 to 0.0052. In another exemplary aspect, the waveguide has a $+\Delta$ of about 0.0020 to 0.0035, a $-\Delta$ of about -0.001 to -0.0015, and a Δ_{Tot} of about 0.0030 to 0.0045.

In one exemplary embodiment, the optical waveguide has a depressed-well clad to core radius ratio of about 3.7 to about 3.8, a $+\Delta$ of about 0.0031, a $-\Delta$ of about -0.0017, and a Δ_{Tot} of about 0.0049. In another exemplary embodiment, the waveguide has a

depressed-well clad to core radius ratio of about 3.6, a $+\Delta$ of about 0.0032, a $-\Delta$ of about -0.0011, and a Δ_{Tot} of about 0.0043. An exemplary core diameter for a waveguide in accordance with the present invention is about 9-12 micrometers. An exemplary operating wavelength range is between about 1300 to 1650 nm and a second mode cabled cutoff wavelength of less than 1260 nm. An exemplary MFD is greater than or equal to about 9.6 microns when measured at 1550 nm.

In particular exemplary embodiments, the optical waveguide has a glass core and claddings, and further includes a polymer coating, such as a hard polymer coating, permanently bonded or adhered to the outside surface of the glass waveguide. The waveguide may further include a soft polymer material coating the hard polymer, wherein the soft polymer materials may comprises coatings selected from the group of Desolite 3471-3-14, Desolite 3471-1-152A, and Shin-Etsu OF-206.

The inner cladding of exemplary embodiments may include fluorosilicate, borosilicate, phosphorus fluorosilicate, phosphorus borosilicate, germanium fluorosilicate or germanium borosilicate compositions.

The optical waveguide may be an optical fiber, such as a single-mode, triple-band optical fiber. Optical devices including waveguides in accordance with the present invention are also contemplated.

Fibers in accordance with embodiments of the present invention provide tight bend tolerance designs, which allows them to be either fusion spliced or mechanically connected to other high MFD fibers with minimal splice losses.

Thus, waveguides of the present invention can be utilized for premise wiring and patch cables used for connecting equipment to the premise wiring that can operate at wavelengths in the 1300 nm and/or 1550 nm bands, and may further include system monitoring signals out past 1650 nm. The waveguides can have mode field diameters approximately matching that of telecommunications fibers such as Corning SMF-28™ single mode fiber, and can mechanically and optically tolerate prolonged bends with a bend radius less than one quarter of an inch (or 12 mm). Patch cord fiber implementations would preferably work from 1300 nm to 1650 nm (and longer), as 1380 nm range losses due to hydroxyl ion contamination would be negligible in the short lengths that patch cords comprise. The local communications systems to which they will be connected, particularly if these are based on fibers such as Corning SMF-28™ or similar span fibers utilized in communications systems, could be operating at any (or all) wavelengths. For

such premise wiring and patch cables, which may include small single or duplex fiber optic cables, the fibers are designed to tolerate (both optically and mechanically) small radius bends, both for routing within walls and for jumper cables which may connect a fiber optic wall outlet to a computer or other piece of equipment.

5

BRIEF DESCRIPTION OF THE DRAWINGS

Figure 1 is an isometric view of a cross-sectional cut of a waveguide in accordance with the present invention.

Figure 2 is a graph depicting an actual refractive index profile along the diameter of an optical preform in accordance with an embodiment of the present invention.

10 Figure 3 is a comparison graph of attenuation vs. wavelength for a 10 mm bend radius comparing an embodiment of the present invention with a dual-wave fiber and a Corning SMF-28 fiber.

Figure 4 is a schematic diagram of an exemplary index profile graph for an exemplary optical fiber in accordance with an embodiment of the present invention.

15 Figure 5 is a schematic diagram of an exemplary index profile graph for another exemplary optical fiber in accordance with an embodiment of the present invention.

Figure 6 is graph of calculated bend loss for another exemplary optical fiber in accordance with an embodiment of the present invention, where the fiber has the following values: a $+\Delta$ of about 0.0033, a $-\Delta$ of about -0.0016, a core radius (r_{co}) of about
20 5 μm and a varying inner cladding radius (r_{ic}).

Figure 7 is a graph of calculated dependence of bend loss on the core and depressed clad index levels for an optical fiber having a $\Delta_{Tot} = 0.0049$.

Figure 8 is a graph of adjusted theoretical cable cut off wavelength as a function of $+\Delta$ for another exemplary optical fiber.

25 Figure 9 is a index profile graph for an exemplary optical preform prior to overcollapse in accordance with Example 4.

DETAILED DESCRIPTION

As discussed above, the low attenuation design of some conventional fibers (e.g., SMF-28) result in high bend losses in tight bend applications. The present invention is
30 directed to an optical waveguide, such as an optical fiber, that is closely mode matched to a conventional fiber (e.g., SMF-28) and has a satisfactory bend loss across the operating

bands including 1300 nm to 1650 nm. According to the present description, three wavelength bands of particular interest include a first wavelength band centered at about 1300 nm (e.g., $1300 \text{ nm} \pm 20 \text{ nm}$), a second wavelength band centered at about 1550 nm (e.g., $1550 \text{ nm} \pm 50 \text{ nm}$), and a third wavelength band centered at about 1625 nm (e.g., $1625 \text{ nm} \pm 50 \text{ nm}$). The second wavelength band of interest centered at about 1550 nm can include the short, center, and long bands (i.e., S-, C-, and L-bands) of Erbium transmission. In addition, the wavelength band from about 1360 nm to about 1460 nm can also be utilized, especially in patch cord applications, which cover shorter distances.

Figure 1 shows an optical fiber 10 constructed in accordance with the present invention. Optical fiber 10 includes a protective coating 20 and a buffer 30. Optical fiber 10 further includes a core 12, inner cladding 14, and an outer cladding 16. The core 12, the inner cladding 14, and the outer cladding 16 are exemplarily constructed of glass, but may also be constructed of any suitable material. The claddings 14 and 16 also may be constructed from materials other than glass, such as fluoropolymers, fluoroelastomers, and silicones. One additional glass layer 18 concentrically surrounds the glass core and claddings. The layer 18 is the original support material collapsed from the initial preform tube, generally comprising silica glass.

Protective coating 20 is a coating described below and surrounds the layer 18. The protective coating can include the polymer-based coating formulations disclosed in commonly-owned US Patent No. 6,587,628. These materials are generally coatings for GGP fibers, which include UV-curable compositions cured with a photoinitiator such as an iodonium methide salt that does not hydrolyze to release HF or Fluoride ion, or an iodonium methide photoinitiator. These polymer-based protective coatings also provide protection for the glass surface from scratches and the moisture induced reduction in mechanical strength.

The buffer 30 longitudinally encloses optical fiber 10 includes in the particular embodiment illustrated an inner, resilient layer 22 and an outer, rigid layer 24. Inner, resilient layer 22 provides optical fiber 10 with protection against microbending losses while outer, rigid layer 24 protects the underlying layers from abrasion and mechanical damage.

Figure 2 graphically illustrates the refractive index profile along the diameter of an embodiment of an optical fiber 10 in accordance with the present invention. Fiber 10, for this embodiment, was constructed as described below in Example 3.

Figure 3 shows a comparison graph of attenuation vs. wavelength for a 10 mm bend radius comparing the same example tri-wave (TW) fiber with a dual-wave (DW) fiber, such as is described in commonly-owned, currently pending US Patent Application No. 10/172,093 (incorporated by reference herein), and a conventional SMF-28 fiber. It is noted that the example TW fiber provides an order of magnitude improvement in bend loss performance as compared to SMF-28 for the 1550 nm and 1625 nm bands. Significant improvement in bend loss performance is also noted for the TW design as compared to a DW design for the 1550 nm and 1625 wavelength bands.

The optical fiber 10 can be a single-mode uncoated optical fiber having a circular cross-section. It is to be understood that other embodiments of the present invention may include multi-mode fibers, fibers with coatings, and fibers having different cross-sectional geometries known in the art.

The optical fiber 10 includes the core 12 having a first transverse dimension or diameter $2r_{co}$ and having a refractive index n_{co} . Laterally surrounding the core 12 is an inner cladding 14 having a width W , $(r_{ic} - r_{co})$, an inner cladding or barrier radius r_{ic} and a refractive index n_{ic} . The outer cladding 16, having a refractive index n_{oc} , laterally surrounds the inner cladding 14.

The refractive index of the air or other external medium or cladding surrounding the optical fiber is denoted as n_{ext} .

Unlike a typical matched cladding fiber, the optical fiber 10 has a depressed inner cladding configuration. As can be appreciated from Figure 2, for fiber 10 the refractive index of the core n_{co} has a greater absolute value than the refractive index of the outer cladding n_{oc} . In turn, the refractive index of the outer cladding has a greater absolute value than the refractive index of the inner cladding n_{ic} . Accordingly,

$$n_{co} > n_{oc} > n_{ic}$$

The equations for the normalized index delta are:

$$+\Delta = (n_{co} - n_{oc})/n_{oc};$$

$$-\Delta = (n_{ic} - n_{oc})/n_{oc}; \text{ and}$$

$$\Delta_{Tot} = |(+\Delta)| + |(-\Delta)|,$$

where n_{co} is the effective step index of the core;

n_{ic} is the refractive index of the inner cladding (the depressed well or moat); and

n_{oc} is the refractive index of the outer cladding.

According to an exemplary embodiment, Fig. 4 shows an exemplary depressed-well index profile for a fiber having a triple-band wavelength of operation, with low attenuation losses in high bend radii environments (e.g., less than or equal to 0.7 dB/turn when measured on a 10 mm radius bend at 1625 nm). For example, Fig. 4 shows a fiber structure having an inner clad and core radius ratio of about 3.0 to about 5.0, a $+\Delta$ of about 0.0020 to 0.0035, a $-\Delta$ of about -0.001 to -0.0015, and a Δ_{Tot} of about 0.0030 to 0.0045.

According to another exemplary embodiment, Fig. 5 shows another exemplary depressed-well index profile for a fiber having a triple-band wavelength of operation, with low attenuation losses in very high bend radii environments (e.g., 5 mm radius bend at 1625 nm). As shown in Fig. 5, a fiber can be produced having a bend loss of less than or equal to 0.7 dB/turn at 1550 nm and less than or equal to 1.0 dB/turn at 1625 nm and less than or equal to 1.5 dB/turn at 1650 nm at a bend radius of 5 mm. For example, Fig. 5 shows a fiber structure having an inner clad and core radius ratio of greater than or equal to 3.6, a $+\Delta$ of about 0.0030 to 0.0036, a $-\Delta$ of about -0.0018 to -0.0012, and a Δ_{Tot} of about 0.0048 to 0.0052. Combined with a core diameter of about 9 μm – 12 μm , the optical fiber shows a mode field diameter at 1550 nm $\geq 9.6 \mu\text{m}$ and a cabled cut off wavelength $< 1260 \text{ nm}$, while keeping good bend performance.

Calculated results of bend loss versus different depressed inner clad thicknesses are shown in Figure 6. This theoretical calculation was been carried out using a FiberCad program and Beam Propagation Method (BPM) for a fiber bend radius of 5 mm. The depicted exemplary fiber has a $+\Delta$ of about 0.0033, a $-\Delta$ of about -0.0016, a core radius (r_{co}) of about 5 μm and a varying cladding radius (r_{ic}). The bend radius is 5 mm. This figure indicates that suitable bend performance can be achieved for the ratio $r_{ic}/r_{co} \geq 3.6$. The bend loss will increase at an accelerated rate when the r_{ic}/r_{co} ratio decreases. The investigators have further determined that an increase in bend loss is directly related to an increase in MFD when r_{ic}/r_{co} is less than 3.6. Figure 6 also indicates that the error margin between measured bend loss and calculated bend loss is about 0.5 dB/turn.

Figure 7 shows a calculation for bend losses in a model fiber, when the refractive index levels of the fiber core and the depressed clad can be varied to produce suitable bend performance of the fibers. In Fig. 7, the value for Δ_{Tot} has been fixed at 0.0049 and the MFD at 1550 nm has a constant value of 9.6 μm based on calculation. Fig. 7 indicates that the calculated bend losses have minimum values around a $+\Delta$ of about 0.0036 and a -

Δ of about -0.0012 for 1550 nm. Fig. 7 also indicates that the minima in bend loss with a 5 mm bend radius (e.g., of a fiber wrapped around a 5 mm mandrel) are slightly different at 1550 nm and 1650 nm, although the range of bend loss value is only about 0.1 dB/turn among the different fiber designs.

5 An upper value for $+\Delta$ for suitable bend operation, based on a specified cable cut off wavelength (e.g., 1260 nm), can also be determined. For example, as shown in Figure 8, a value of $+\Delta$ of about 0.0036 (adjusted to experimental values) has been indicated.

Experimental Data

Example 1

10 One exemplary embodiment of an optical fiber in accordance with the present invention has the following material composition:

A preform having the material composition described above was manufactured using the modified chemical deposition (MCVD) process using a 19 x 25 mm fused silica tube by first depositing 20 cladding layers with flows of 412, 40 and 19 standard cc/min of
15 SiCl_4 , POCl_3 , and SiF_4 , respectively. This was followed by 7 core layers consisting of 96 and 90 standard cc/min of SiCl_4 and GeCl_4 , respectively, followed by two collapse passes and one seal pass resulting in a preform diameter of 17.8 mm. One or more overcollapses using 19 x 25 mm fused silica tubes may be required to obtain a final preform diameter of 23 mm. The refractive index profile of this preform prior to overcollapse is shown in
20 Figure 2. The preform was overcollapsed prior to drawing, and was drawn as an optical fiber.

In the present example, a hard, permanent polymer coating is placed on the outer surface of the glass portion to a diameter of 125.0 microns. A second, softer coating is applied over the UV curable primary coating to a diameter of approximately 180 microns.
25 Typical materials used for this softer coating layer may include Desolite 3471-3-152A or Desolite 3471-3-14, available from DSM Desotech, Inc., 1122 St. Charles St., Elgin, IL, 60120, or Shin-Etsu OF-206, available from Shin-Etsu Chemical Co., Ltd., 6-1, Otemachi 2-chome, Chiyoda-ku, Tokyo 100-0004, Japan. A third, harder coating is applied over the secondary coating to provide a durable outer coating. Typical materials for use as this
30 harder coating may include Desolite 3471-2-136, Desolite 3471-3-14, also available from DSM Desotech, Inc. (Desolite 3471-3-14 is described as an intermediate hardness

material which can be used for single-coat applications.) Commonly-assigned US Patent RE 36,146; US Patent No. 6,587,628; and US Patent No. 6,895,156, all of which are hereby incorporated by reference, discuss various possible coating compositions. The softer second coating helps reduce microbending losses by cushioning micro-stress points rather than transmitting micro-stresses to the light-carrying core.

The outer two coatings are easily stripped from the permanently bonded primary coating resulting in a protected fiber end having a coated diameter of 125.0 microns. This diameter is controlled in such a way that the stripped fiber end will fit in standard 125 micron connector ferrules.

The example fiber had the following characteristics:

- a.) clad/core radius ratio is 3.6
- b.) $+\Delta$ of 0.0032
- c.) $-\Delta$ of -0.0011
- d.) Δ_{Tot} of 0.0043

The procedure to measure bend loss followed the guidelines set forth in the EIA/TIA-455-62-A (FOTP 62) industry standard test method. Basically, the bend loss of the fiber was measured by wrapping the fiber around a mandrel having the specified radius, a predetermined number of turns and then measuring the difference in transmission between the same fiber in a straight configuration and the bent configuration.

This design resulted in example fiber with the following properties:

Cutoff wavelength = 1280 nm

MFD @ 1300 nm = 7.9 microns

MFD @ 1550 nm = 8.8 microns

Bend loss (10 mm radius) < 0.004 dB/turn @ 1550 nm

Bend loss (10 mm radius) = 0.01 dB/turn @ 1625 nm

Bend loss (10 mm radius) = 0.02 dB/turn @ 1650 nm.

Example 2

A second sample of optical fiber having a similar design in accordance with the present invention was drawn and measured, with the following properties:

- a.) clad/core radius ratio is 3.9
- b.) $+\Delta$ of 0.0027
- c.) $-\Delta$ of -0.0012

d.) Δ_{Tot} of 0.0039.

This design resulted in example fiber with the following properties:

Cutoff wavelength = 1310 nm

MFD @ 1300 nm = 8.1 microns

5 MFD @ 1550 nm = 9.2 microns

Bend loss (10 mm radius) = 0.02 dB/turn @ 1550 nm

Bend loss (10 mm radius) = 0.08 dB/turn @ 1625 nm

Bend loss (10 mm radius) = 0.12 dB/turn @ 1650 nm

10 Index delta values were taken from measurements done on the fiber preforms before fiber drawing. The measurements were done with a He-Ne laser at 633 nm. The refractive index of the outer cladding in these fibers is essentially the same as pure silica, which for calculation purposes was taken to be 1.458 at 633 nm.

Example 3

15 The bend performance of an optical fiber in accordance with another embodiment of the present invention (SMGGP-TW) was compared with commercially available SMF-28™ fiber from Corning, with commercially available Volition™ single wavelength band fiber (SMGGP-SW), and a dual wavelength band fiber (SMGGP-DW, as described in commonly-owned, currently pending US Patent Application No. 10/172,093) from 3M Company, St. Paul, Minnesota. The results are shown in Table 1.

20

Table 1

	+ Δ	- Δ	Δ_{Tot}	$R_{\text{ic}}/R_{\text{co}}$	Cutoff Cable nm	MFD 1300nm μm	MFD 1550nm μm	Bend loss		
								1550nm dB/turn	1625nm dB/turn	1550nm dB 1/4 turn
Corning SMF-28™	0.0035		0.0035		<1260	9.2	10.4	0.38	0.6	2.4
SMGGP-SW	0.0024		0.0024		<1160	9.2	10.4	1	1.6	3.3
SMGGP-DW	0.0020	-0.0028	0.0048	2.6	<1180	9.0	10.0	0.6	1.2	0.12
SMGGP-TW	0.0025	-0.0016	0.0041	3.4	<1260	8.6	9.4	0.1	0.3	0.05

25 In the above table, the bend loss measurements for columns 9 and 10 were measured using a 10 mm bend radius, and the bend loss measurements shown in column 11 (last column) were measured using a 6 mm bend radius (1/4 turn). The table above shows that the SMGGP-TW fiber has much lower bend loss at 1625 nm wavelength compared to the SMGGP-SW and SMGGP-DW fiber designs. For example, bend losses

on the SW design were about 1.6 dB/turn at a 10 mm radius and 1.2 dB/turn for the DW design while the triple wavelength (TW) design is about 0.3 dB. Although the mode field diameter (MFD) of the TW fiber is slightly smaller than the SW and DW designs, the added connectivity losses are less than 0.03 dB per connection at 1300 nm and 1550 nm.

5 The TW fiber was designed to match the “cabled” cutoff characteristics of the Corning, SMF-28™, as measured per EIA/TIA-455-170 (FOTP 170) rather than a “fiber” cutoff resulting in a higher numerical aperture design which contributes to the better bend performance. The SW and DW fibers were designed to have fiber cutoffs of less than 1260 nm and 1280 nm, respectively, resulting in cabled cutoffs of less than about 1180

10 nm. The added mode spreading at the longer wavelengths due to the shorter cabled cutoff resulted in the fundamental mode bending out at a rapid rate on the DW design. The SW design was similarly penalized.

Example 4

Another exemplary embodiment of an optical fiber in accordance with the present invention has the following material composition:

15

A preform having the material composition described above was manufactured using the modified chemical deposition (MCVD) process using a 19 x 25 mm fused silica tube by first depositing 23 cladding layers with flows of 667, 23 standard cc/min of SiCl₄ and SiF₄, respectively. This was followed by 7 core layers of 138 and 114 standard cc/min

20 of SiCl₄ and GeCl₄, respectively, followed by several collapse seal passes resulting in a preform diameter of 15.2 mm. One overcollapse tube with the appropriate cross section area is used to obtain a final preform diameter of about 23 mm.

The refractive index profile of this preform prior to overcollapse is shown in Figure 9. The preform was overcollapsed prior to drawing, and was drawn as an optical

25 fiber. In the present example, a hard, permanent polymer coating is placed on the outer surface of the glass portion to a diameter of 125.0 microns. A second, softer coating is applied over the UV curable primary coating to a diameter of approximately 180 microns. Typical materials used for this softer coating layer may include Desolite 3471-3-152A or Desolite 3471-3-14, available from DSM Desotech, Inc., 1122 St. Charles St., Elgin, IL,

30 60120, or Shin-Etsu OF-206, available from Shin-Etsu Chemical Co., Ltd., 6-1, Otemachi 2-chome, Chiyoda-ku, Tokyo 100-0004, Japan. A third, harder coating is applied over the secondary coating to provide a durable outer coating. Typical materials for use as this

harder coating may include Desolite 3471-2-136, Desolite 3471-3-14, also available from DSM Desotech, Inc. (Desolite 3471-3-14 is described as an intermediate hardness material which can be used for single-coat applications.) Commonly-assigned US Patent RE 36,146, US Patent No. 6,587,628, and US Patent No. 6,895,156, all of which are
5 hereby incorporated by reference, discuss various possible coating compositions. The softer second coating helps reduce microbending losses by cushioning micro-stress points rather than transmitting micro-stresses to the light-carrying core.

The outer two coatings can be easily stripped from the permanently bonded primary coating resulting in a protected fiber end having a coated diameter of 125.0
10 microns. This diameter is controlled in such a way that the stripped fiber end will fit in standard 125 micron connector ferrules.

This example fiber had the following characteristics:

- a.) clad/core radius ratio is 3.8
- b.) $+\Delta$ of 0.0031
- 15 c.) $-\Delta$ of -0.0018
- d.) Δ_{Tot} of 0.0049.

The procedure to measure bend loss followed the guidelines set forth in the EIA/TIA-455-62-A (FOTP 62) industry standard test method. The bend loss of the fiber was measured by wrapping the fiber around a mandrel having the specified radius, a
20 predetermined number of turns and then measuring the difference in transmission between the same fiber in a straight configuration and the bent configuration.

This design resulted in example fiber with the following properties:

- Cutoff wavelength = 1263 nm
- MFD @ 1310 nm = 8.8 microns
- 25 MFD @ 1550 nm = 9.7 microns
- Bend loss (10 mm radius) = 0.1 dB/turn @ 1550 nm
- Bend loss (10 mm radius) = 0.22 dB/turn @ 1625 nm
- Bend loss (10 mm radius) = 0.25 dB/turn @ 1650 nm
- Bend loss (5 mm radius) = 0.66 dB/turn @ 1550 nm
- 30 Bend loss (5 mm radius) = 1.0 dB/turn @ 1625 nm
- Bend loss (5 mm radius) = 1.05 dB/turn @ 1650 nm

Example 5

Another sample optical fiber having a similar design in accordance with the present invention was drawn and measured (in accordance with the general method described above), with the following properties:

- 5 a.) clad/core radius ratio is 3.6
- b.) $+\Delta$ of 0.0033
- c.) $-\Delta$ of -0.0018
- d.) Δ_{Tot} of 0.0051.

This design resulted in example fiber with the following properties:

- 10 Cutoff wavelength = 1265 nm
- MFD @ 1310 nm = 8.8 microns
- MFD @ 1550 nm = 9.6 microns
- Bend loss (10 mm radius) = 0.11 dB/turn @ 1550 nm
- Bend loss (10 mm radius) = 0.25 dB/turn @ 1625 nm
- 15 Bend loss (10 mm radius) = 0.43 dB/turn @ 1650 nm
- Bend loss (5 mm radius) = 0.71 dB/turn @ 1550 nm
- Bend loss (5 mm radius) = 0.86 dB/turn @ 1625 nm
- Bend loss (5 mm radius) = 1.0 dB/turn @ 1650 nm

Index delta values were taken from measurements done on the fiber preforms
20 before fiber drawing. The measurements were performed using a He-Ne laser at about 633 nm. The refractive index of the outer cladding in these fibers is essentially the same as pure silica, which for calculation purposes was taken to be 1.4573 at 633 nm.

Example 6

The bend performance of an optical fiber in accordance with another embodiment
25 of the present invention (identified below as "SMGGP-TW2") was compared with an available fiber, SWCC SM-E, an optical fiber available from Showa Electric Wire & Cable Co., Ltd., of Japan, which has step index core profile and reduced mode field diameter compared to standard single mode fiber. The optical fiber SMGGP-TW2 was formed in a manner similar to that described above for examples 4 and 5. The results are
30 shown in Table 2.

Table 2

	+ Δ	- Δ	Δ_{Tot}	r_{ic}/r_{co}	Cutoff Cable Nm	MFD 1310nm μm	MFD 1550nm μm	Bend loss		
								1550nm dB/10mm turn	1625nm dB/ 10mm turn	1550nm dB/5mm turn
SWCC SM-E	0.0041		0.0041		<1260	8.4	9.4	0.025	0.1	4.1
SMGGP-TW2	0.0032	-0.0016	0.0048	3.65	<1260	8.7	9.5	0.07	0.21	0.7

In Table 2, bend loss measurements were made for the radius indicated in the column header.

5 Those skilled in the art of optical waveguide manufacturing may readily ascertain a variety of chemical compositions that achieve the index profile disclosed in the present invention. Compositions used to fabricate modified chemical vapor deposition preforms in accordance with the present invention included a phosphorus fluorosilicate depressed-well inner cladding and a germanium silicate core. Other designs could include the use of
10 phosphorus in the core to soften the glass for easier collapse.

In alternative embodiments, the core may include various index increasing dopant oxides such as phosphorus, germanium, aluminum, or lanthanum or combinations thereof. Similarly, the depressed cladding could be obtained by using fluorine and/or boron or combinations of these along with index enhancers such as the compositions used for the
15 core. Such multi-component glasses may result in higher losses, but may be useful in obtaining other desirable fiber properties such as photosensitivity (for writing Bragg gratings) or a shifted dispersion characteristic.

An outer cladding that substantially matches the index of silica may be added with no change in overall performance. Other possibilities include a partially depressed outer
20 cladding that could result in "softening" the fundamental cutoff versus wavelength characteristic.

An optical fiber in accordance with embodiments of the present invention has the ability to tolerate tight bends without resulting in undue mechanical stress, bend induced optical loss, or mechanical splice loss when connected to standard, high MFD fibers such
25 as Corning's SMF-28. An exemplary design is capable of providing this performance at both of the common telecommunication operating wavelength windows of 1300 and 1550 nm as well as including the 1625 nm - 1650 nm window that can be used for system monitoring. Special fiber constructions include smaller glass diameters that permit tighter bends without overstressing the fiber mechanically and can be combined with permanent

coating technology (so-called "GGP" fiber) to build the glass diameter up from 80 - 100 microns to 125 microns. This permits the fibers to be connected using commonly available mechanical connectors designed for 125 micron glass diameter fibers.

5 The fiber design of embodiments of the present invention provides good modal confinement over a broad spectral range permitting one fiber to operate from 1300 to 1650 nm with minimal bend induced losses, while still being sufficiently mode matched to SMF-28 to provide low loss mechanical interconnection. The special depressed-well design is more bend tolerant than the matched clad design and offers an advancement in the state-of-the-art for mode matching to standard fibers, and would be useful for fiber-to-
10 the-board applications. The term "fiber-on-the-board" refers to optical fibers routed on electronic circuit boards and backplanes, as disclosed in commonly-assigned US patents 5,902,435 and 6,390,690.

Combining the triple wavelength window property of the glass design with the "permanent", precisely applied primary coating technology results in a fiber that can be
15 used for both fiber-on-the-board and 1300-1650 nm applications (such as the VF-45TM patchcord connector where a 0.8" (2.03 cm) diameter bend is required). Another possible application for the present invention is FTTX, where the benefits of simplified mechanical splicing and interconnection would be valuable, e.g., for field termination and drop cable applications.

20 Those skilled in the art will appreciate that the present invention may be used in a variety of optical designs and that fibers in accordance with the present invention may be used in a variety of optical devices. While the present invention has been described with a reference to exemplary preferred embodiments, the invention may be embodied in other specific forms without departing from the spirit of the invention. Accordingly, it should
25 be understood that the embodiments described and illustrated herein are only exemplary and should not be considered as limiting the scope of the present invention. Other variations and modifications may be made in accordance with the scope of the present invention.

What is Claimed is:

1. An optical fiber, comprising:
a core, an inner cladding laterally surrounding the core, and an outer cladding laterally surrounding the inner cladding, wherein the core, inner cladding, and outer
5 cladding have a depressed well configuration,
wherein said fiber operates in three or more wavelength bands, wherein a first wavelength band is centered at about 1300 nm, and wherein a second wavelength band is centered at about 1625 nm, and
wherein the fiber has bend losses that are less than or equal to 0.7 dB/turn when
10 measured on a 10 mm radius bend at 1625 nm.
2. The optical fiber of claim 1, wherein the fiber has bend losses that are less than or equal to 1.0 dB/turn when measured on a 5 mm radius bend at 1625 nm and bend losses that are less than or equal to 1.5 dB/turn when measured on a 5 mm radius bend at 1650 nm.
- 15 3. The optical fiber of claim 1 or 2, further comprising:
a polymer coating adhered to the outer cladding, wherein the polymer coating comprises a material having a Shore D hardness value of at least 55.
4. The optical fiber of claim 1, wherein:
 - a) the core has a refractive index n_{co} and a radius r_{co} ;
 - 20 b) the inner cladding has a refractive index n_{ic} and an outer radius of r_{ic} ;
 - c) the outer cladding has a refractive index n_{oc} ;
 - d) wherein $n_{co} > n_{oc} > n_{ic}$, with
 - e) the range of the ratio of the inner, depressed-well clad radius, r_{ic} , to core radius, r_{co} , varying from about 3.0 to 5.0;
 - 25 f) a $+\Delta$ of about 0.0020 to 0.0035;
 - g) a $-\Delta$ of about -0.001 to -0.0015; and
 - h) a Δ_{Tot} of about 0.0030 to 0.0045.

5. The optical fiber of claim 4, wherein:
- a) the depressed-well clad to core radius ratio is about 3.6;
 - b) the $+\Delta$ is about 0.0032;
 - c) the $-\Delta$ is about -0.0011; and
 - 5 d) the Δ_{Tot} is about 0.0043.
6. The optical fiber of claim 4, wherein:
- a) the depressed-well clad to core radius ratio is about 3.9;
 - b) the $+\Delta$ is about 0.0027;
 - c) the $-\Delta$ is about -0.0012; and
 - 10 d) the Δ_{Tot} is about 0.0039.
7. The optical fiber of claim 2, wherein:
- a) the core has a refractive index n_{co} and a radius r_{co} ;
 - b) the inner cladding has a refractive index n_{ic} and an outer radius of r_{ic} ;
 - c) the outer cladding has a refractive index n_{oc} ;
 - 15 d) wherein $n_{\text{co}} > n_{\text{oc}} > n_{\text{ic}}$, with
 - e) the range of the ratio of the inner, depressed-well clad radius, r_{ic} , to core radius, r_{co} , varying from about 3.0 to 5.0;
 - f) a $+\Delta$ of about 0.0030 to 0.0036;
 - g) a $-\Delta$ of about -0.0018 to -0.0012; and
 - 20 h) a Δ_{Tot} of about 0.0048 to 0.0052.
8. The optical fiber of claim 7, wherein:
- a) the depressed-well clad to core radius ratio is about 3.7 to about 3.8;
 - b) the $+\Delta$ is about 0.0032;
 - c) the $-\Delta$ is about -0.0017; and
 - 25 d) the Δ_{Tot} is about 0.0049.
9. The optical fiber of any of the preceding claims, wherein the optical fiber is a single-mode optical fiber having a core diameter of about 9-12 micrometers.

10. The optical fiber of any of the preceding claims, having an operating wavelength range between about 1300 to 1650 nm and a cabled cutoff wavelength of less than or equal to 1280 nm.
11. The optical fiber of any of the preceding claims, wherein the inner cladding
5 comprises one or more of the following: fluorosilicate, borosilicate, phosphorus fluorosilicate, phosphorus borosilicate, germanium fluorosilicate or germanium borosilicate composition.
12. The optical fiber of claim 7, having bend losses less than or equal to 1.0 dB/turn when measured on a 5 mm radius bend at 1625 nm and bend losses that are less than or
10 equal to 1.5 dB/turn when measured on a 5 mm radius bend at 1650 nm.
13. The optical waveguide of claim 7 having bend losses less than or equal to 0.8 dB/turn when measured on a 5 mm radius bend at 1550 nm.
14. The optical fiber of claim 4, wherein the fiber has bend losses less than or equal to 0.02 dB/turn when measured on a 10 mm radius bend at 1550 nm.
15. The optical fiber of claim 4, wherein the fiber has bend losses less than or equal to
15 0.01 dB/turn when measured on a 10 mm radius bend at 1625 nm.
16. The optical fiber of claim 4, having an MFD between about 7.8 to about 9.0 microns when measured at 1300 nm.
17. The optical fiber of claim 4, having an MFD between about 8.6 to about 10.2
20 microns when measured at 1550 nm.
18. The optical fiber of claim 4, having bend losses less than or equal to 0.15 dB/turn when measured on a 10 mm radius bend at 1550 nm and having bend losses less than or equal to 0.7 dB/turn when measured on a 10 mm radius bend at 1625 nm.
19. The optical fiber of claim 4 having bend losses less than or equal to 0.02 dB/turn
25 when measured on a 10 mm radius bend at 1550 nm.
20. An optical device including the optical fiber of any of the preceding claims.

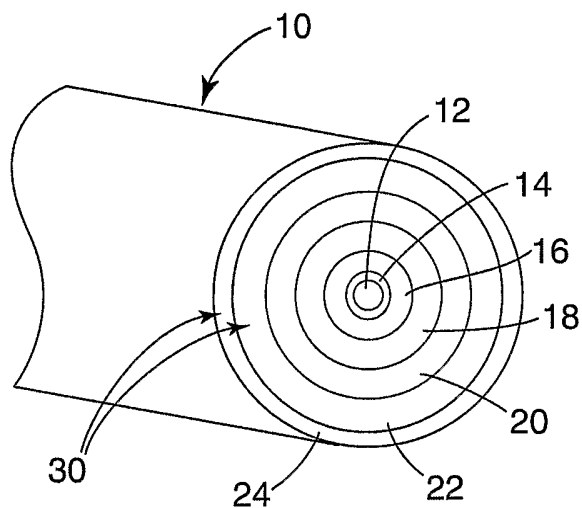

FIG. 1

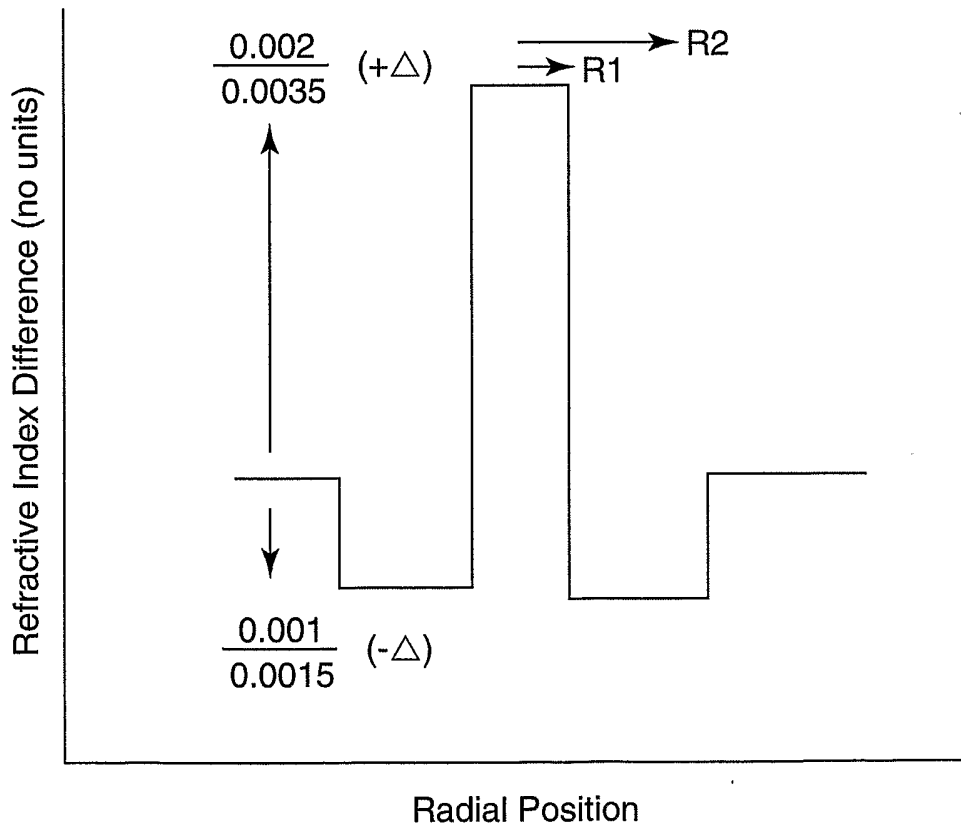
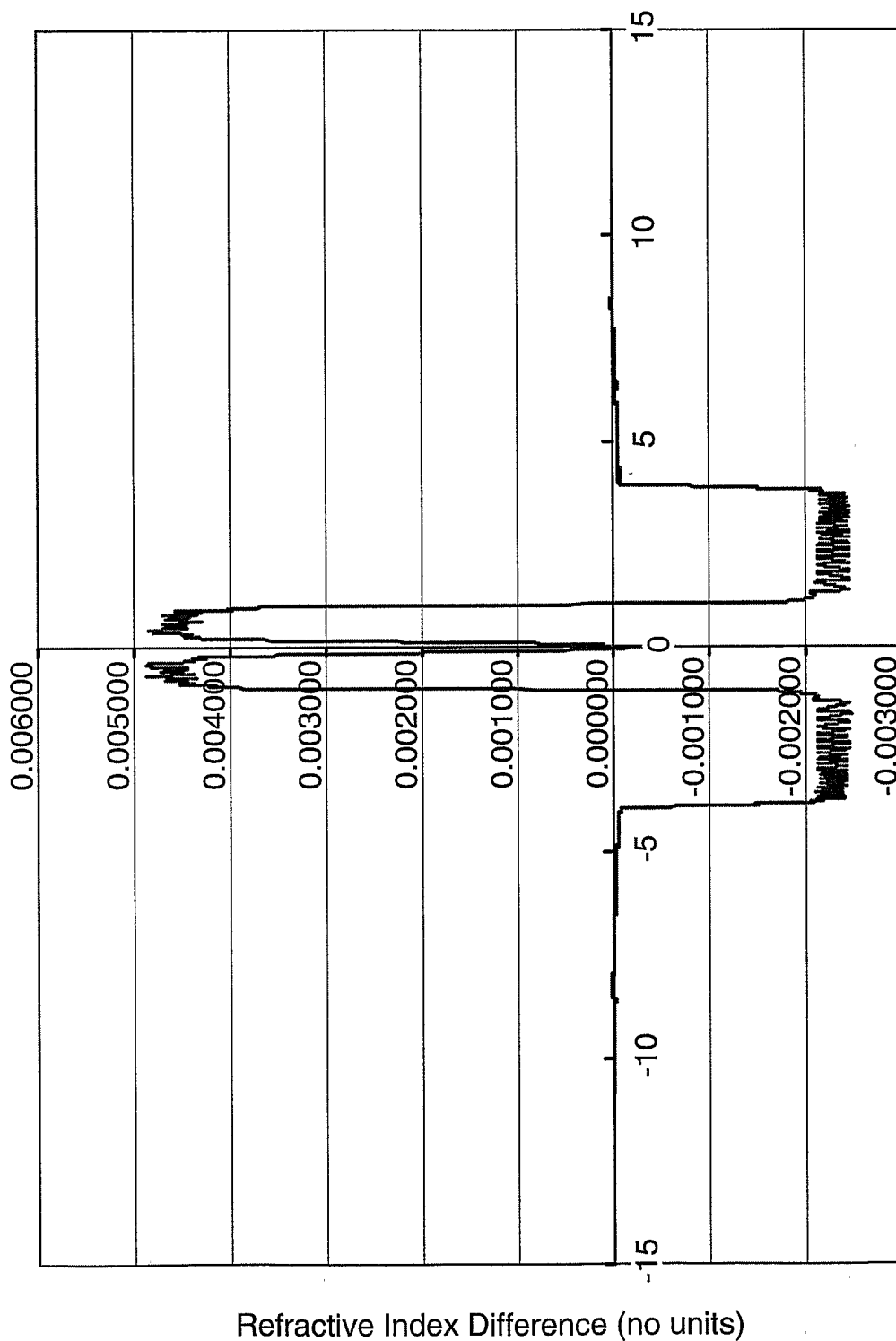

FIG. 4



Radial Position (mm)

FIG. 2

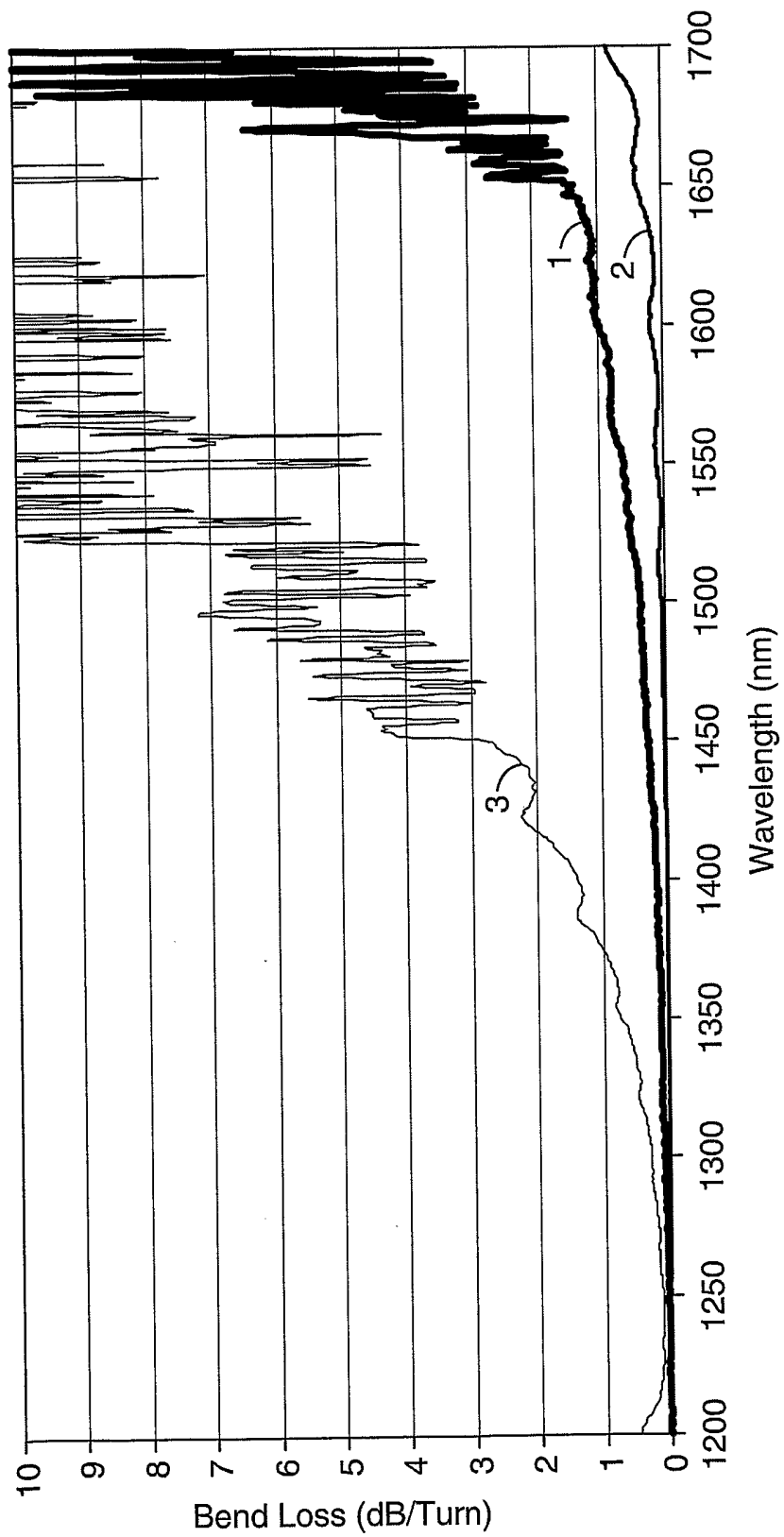
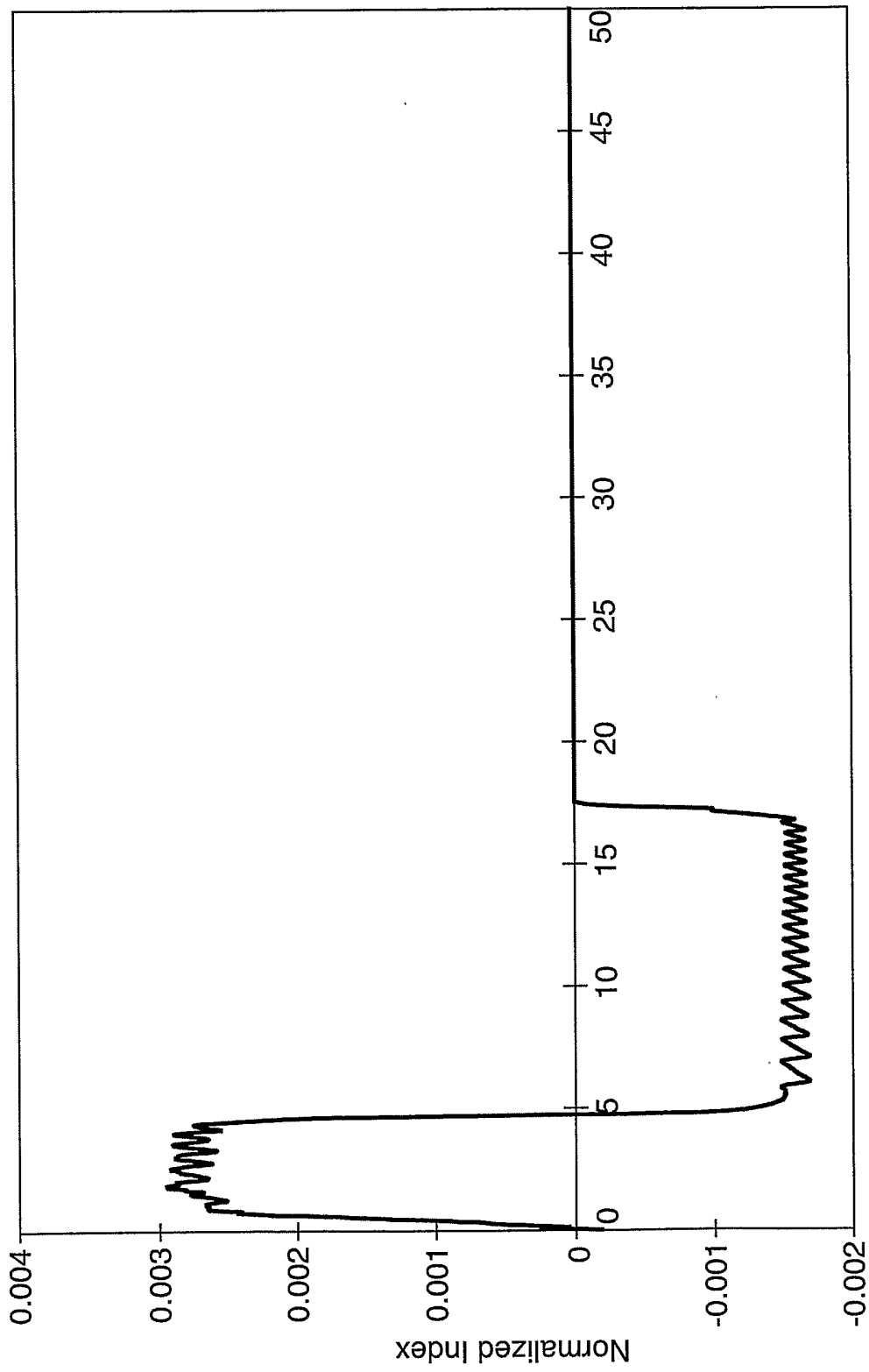

FIG. 3



Fiber Radius (μm)

FIG. 5

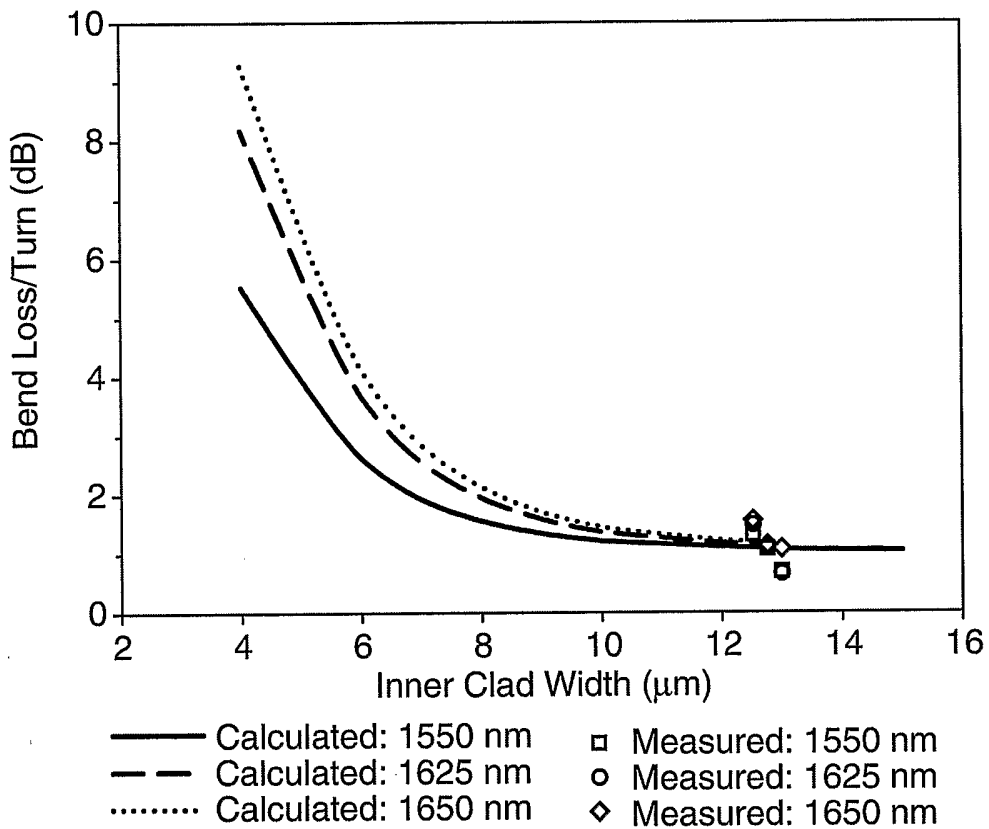
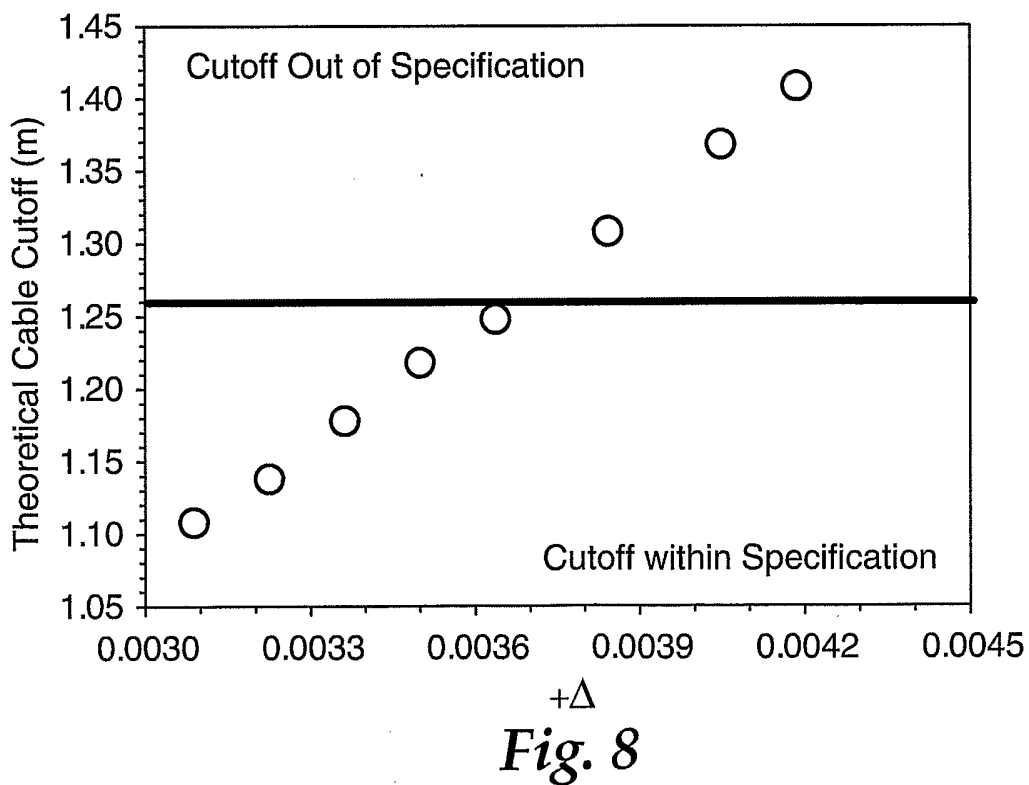
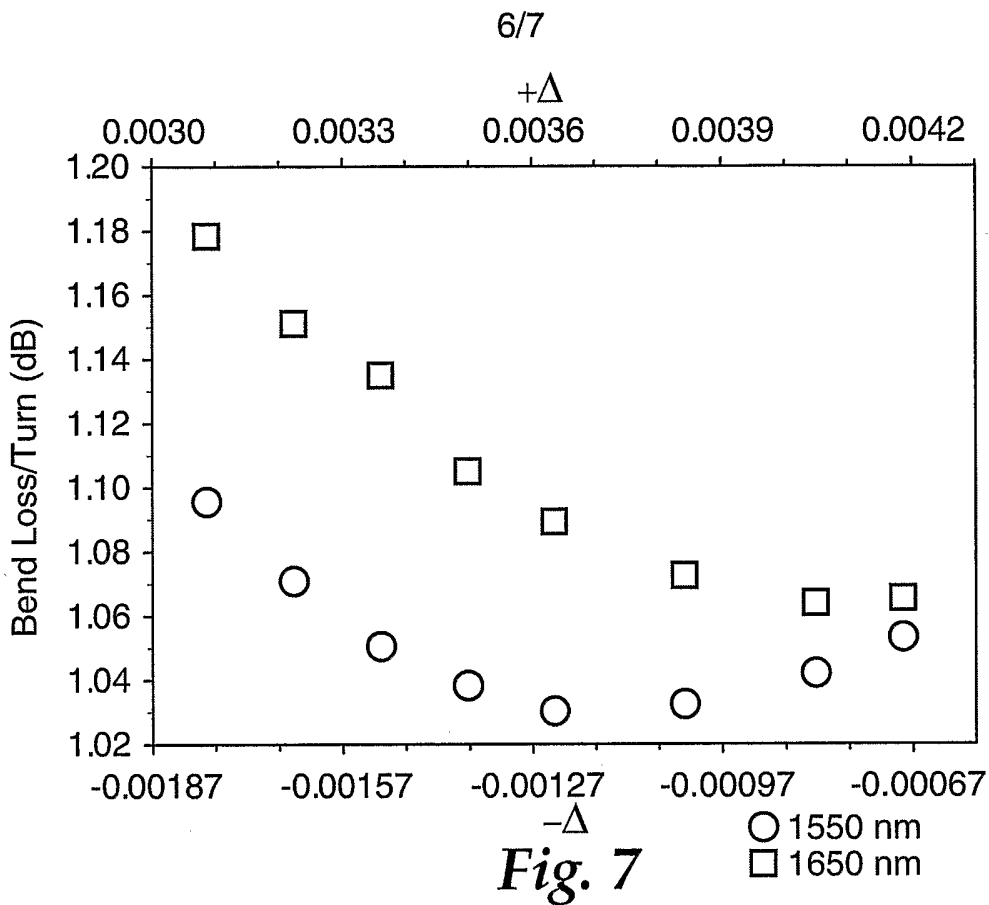
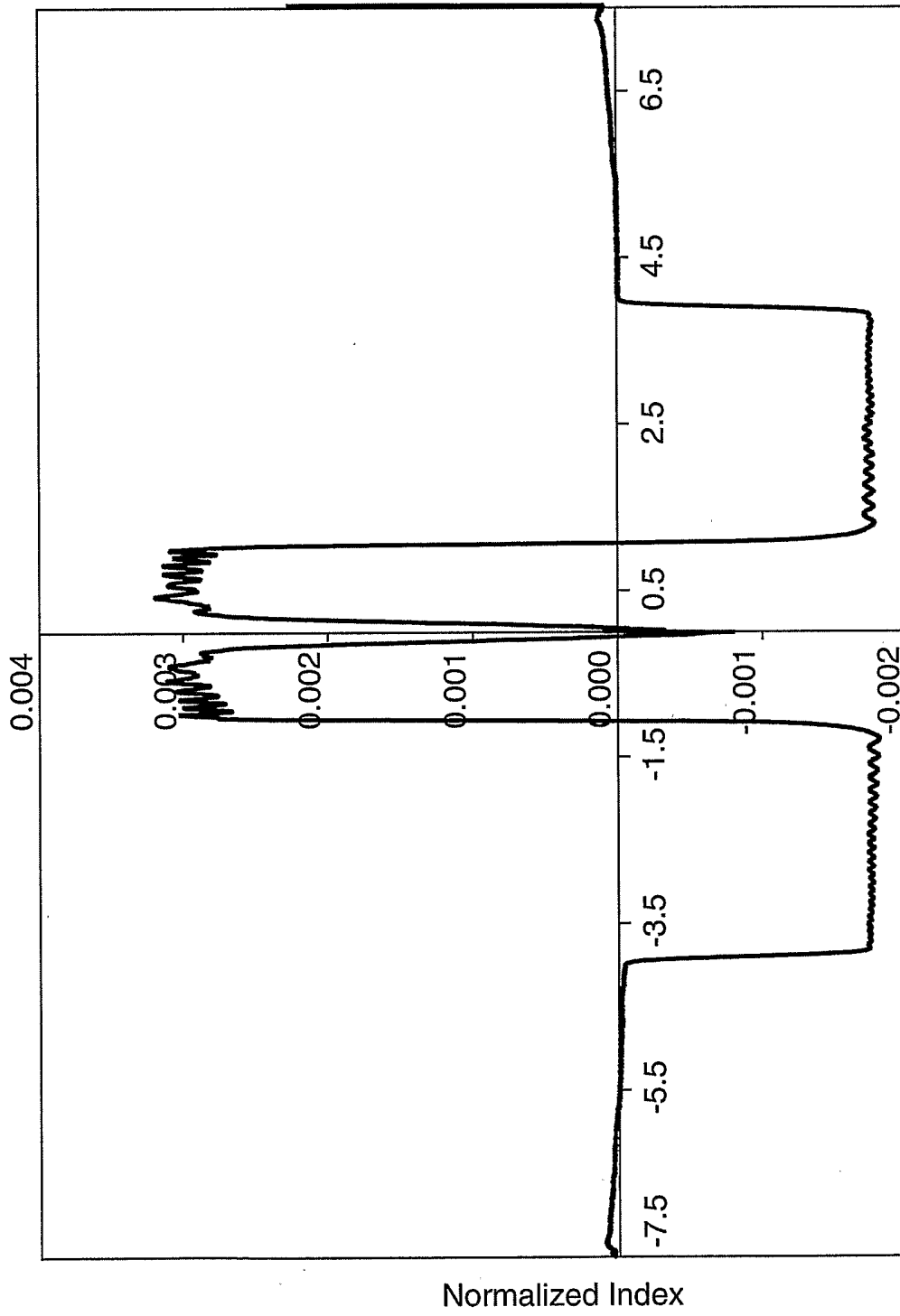

Fig. 6





Preform Radius (mm)

FIG. 9

INTERNATIONAL SEARCH REPORT

International Application No PCT/US2005/030964

A. CLASSIFICATION OF SUBJECT MATTER
G02B6/036 G02B6/44

According to International Patent Classification (IPC) or to both national classification and IPC

B. FIELDS SEARCHED

Minimum documentation searched (classification system followed by classification symbols)
G02B

Documentation searched other than minimum documentation to the extent that such documents are included in the fields searched

Electronic data base consulted during the international search (name of data base and, where practical, search terms used)
EPO-Internal, WPI Data, PAJ, INSPEC

C. DOCUMENTS CONSIDERED TO BE RELEVANT

Category °	Citation of document, with indication, where appropriate, of the relevant passages	Relevant to claim No.
X	EP 1 441 245 A (SAMSUNG ELECTRONICS CO., LTD) 28 July 2004 (2004-07-28) figures 1,3 paragraph '0018! - paragraph '0025!	1-20
X	US 4 836 640 A (GARTSIDE, III ET AL) 6 June 1989 (1989-06-06) figure 4b column 5, line 39 - column 6, line 60	1-20
X	US 2003/026566 A1 (DIEP PHONG ET AL) 6 February 2003 (2003-02-06) figure 6	1-20
X	WO 03/107054 A (3M INNOVATIVE PROPERTIES COMPANY) 24 December 2003 (2003-12-24) the whole document	1-3, 9-11,20
	-/--	

Further documents are listed in the continuation of box C. Patent family members are listed in annex.

° Special categories of cited documents :

A document defining the general state of the art which is not considered to be of particular relevance	*T* later document published after the international filing date or priority date and not in conflict with the application but cited to understand the principle or theory underlying the invention
E earlier document but published on or after the international filing date	*X* document of particular relevance; the claimed invention cannot be considered novel or cannot be considered to involve an inventive step when the document is taken alone
L document which may throw doubts on priority claim(s) or which is cited to establish the publication date of another citation or other special reason (as specified)	*Y* document of particular relevance; the claimed invention cannot be considered to involve an inventive step when the document is combined with one or more other such documents, such combination being obvious to a person skilled in the art.
O document referring to an oral disclosure, use, exhibition or other means	*Z* document member of the same patent family
P document published prior to the international filing date but later than the priority date claimed	

Date of the actual completion of the international search 20 January 2006	Date of mailing of the international search report 30/01/2006
--	--

Name and mailing address of the ISA European Patent Office, P.B. 5818 Patentlaan 2 NL - 2280 HV Rijswijk Tel. (+31-70) 340-2040, Tx. 31 651 epo nl, Fax: (+31-70) 340-3016	Authorized officer Plouzennec, L
--	---

INTERNATIONAL SEARCH REPORT

International Application No
PCT/US2005/030964

C.(Continuation) DOCUMENTS CONSIDERED TO BE RELEVANT		
Category *	Citation of document, with indication, where appropriate, of the relevant passages	Relevant to claim No.
X	EP 1 107 027 A (SUMITOMO ELECTRIC INDUSTRIES, LTD) 13 June 2001 (2001-06-13) "sample 12"figure 8 -----	1
X	US 6 731 847 B1 (KATO TAKATOSHI ET AL) 4 May 2004 (2004-05-04) the whole document -----	1

INTERNATIONAL SEARCH REPORT

Information on patent family members

International Application No PCT/US2005/030964

Patent document cited in search report	A	Publication date	Patent family member(s)	Publication date
EP 1441245	A	28-07-2004	JP 2004226973 A US 2004141703 A1	12-08-2004 22-07-2004
US 4836640	A	06-06-1989	CA 1293878 C CN 87104422 A DE 3789259 D1 DE 3789259 T2 DK 328287 A EP 0256248 A2 ES 2049722 T3 JP 2622380 B2 JP 63010113 A KR 9408674 B1	07-01-1992 20-01-1988 14-04-1994 11-08-1994 28-12-1987 24-02-1988 01-05-1994 18-06-1997 16-01-1988 24-09-1994
US 2003026566	A1	06-02-2003	NONE	
WO 03107054	A	24-12-2003	AU 2003220655 A1 EP 1514145 A1 JP 2005530194 T US 2003231847 A1	31-12-2003 16-03-2005 06-10-2005 18-12-2003
EP 1107027	A	13-06-2001	AU 772900 B2 AU 3678400 A CA 2334888 A1 WO 0062106 A1 US 2001017967 A1	13-05-2004 14-11-2000 19-10-2000 19-10-2000 30-08-2001
US 6731847	B1	04-05-2004	AU 773983 B2 AU 1687100 A CA 2354004 A1 CN 1133083 C DE 69912990 D1 DE 69912990 T2 EP 1145057 A1 WO 0036443 A1 JP 2002532745 T US 2002106172 A1	10-06-2004 03-07-2000 22-06-2000 31-12-2003 24-12-2003 02-09-2004 17-10-2001 22-06-2000 02-10-2002 08-08-2002