



INTERNATIONAL APPLICATION PUBLISHED UNDER THE PATENT COOPERATION TREATY (PCT)

<p>(51) International Patent Classification ⁶ : A61M 1/14</p>	<p>A1</p>	<p>(11) International Publication Number: WO 00/25843</p> <p>(43) International Publication Date: 11 May 2000 (11.05.00)</p>
---	------------------	---

(21) International Application Number: PCT/US99/25620

(22) International Filing Date: 2 November 1999 (02.11.99)

(30) Priority Data:
60/106,710 2 November 1998 (02.11.98) US

(71) Applicant: LIFESTREAM INTERNATIONAL, INC. [US/US]; Suite A, 2828 North Crescent Ridge Drive, The Woodlands, TX 77381 (US).

(72) Inventors: BRINDA, Paul, D.; 4108 Lake Drive, Robbinsdale, MN 55422 (US). HESS, Paul, H.; 18910 39th Avenue North, Plymouth, MN 55446 (US). TOY, Jeffrey, C.; 12620 54th Avenue North, Plymouth, MN 55442 (US).

(74) Agent: LESTER, Michelle, N.; Nixon & Vanderhye P.C., Suite 800, 1100 North Glebe Road, Arlington, VA 22201-4714 (US).

(81) Designated States: AE, AL, AM, AT, AU, AZ, BA, BB, BG, BR, BY, CA, CH, CN, CR, CU, CZ, DE, DK, DM, EE, ES, FI, GB, GD, GE, GH, GM, HR, HU, ID, IL, IN, IS, JP, KE, KG, KP, KR, KZ, LC, LK, LR, LS, LT, LU, LV, MA, MD, MG, MK, MN, MW, MX, NO, NZ, PL, PT, RO, RU, SD, SE, SG, SI, SK, SL, TJ, TM, TR, TT, TZ, UA, UG, UZ, VN, YU, ZA, ZW, ARIPO patent (GH, GM, KE, LS, MW, SD, SL, SZ, TZ, UG, ZW), Eurasian patent (AM, AZ, BY, KG, KZ, MD, RU, TJ, TM), European patent (AT, BE, CH, CY, DE, DK, ES, FI, FR, GB, GR, IE, IT, LU, MC, NL, PT, SE), OAPI patent (BF, BJ, CF, CG, CI, CM, GA, GN, GW, ML, MR, NE, SN, TD, TG).

Published
*With international search report.
Before the expiration of the time limit for amending the claims and to be republished in the event of the receipt of amendments.*

(54) Title: CARDIOPLEGIA HEAT EXCHANGER

(57) Abstract

This invention is cardioplegia heat exchanger including a hollow casing (12) with a heat exchanger (14), and a bubble trap (16). The device also includes an air release port (20). The bubble trap (16) is located at the top of the heat exchanger (14). The device may also have a bubble trap (16) with a downwardly sloping bottom wall (58), and an air release port (20) positioned downstream of a microporous screen (30). The bubble trap (16) may have a vertical cross-sectional area increasing towards the blood outlet (24), and a drain horizontal cross-sectional area (DCSA) decreasing towards the blood outlet (24). The device has the following ratios: DCSA to the effective heat exchanger cross-sectional area (EHECSA) is from about 3.6 to about 11.8, open cross-sectional area (OCSA) to DCSA is from about 1.4 to about 2.3, and OCSA to EHECSA is from about 8.1 to about 17.0.

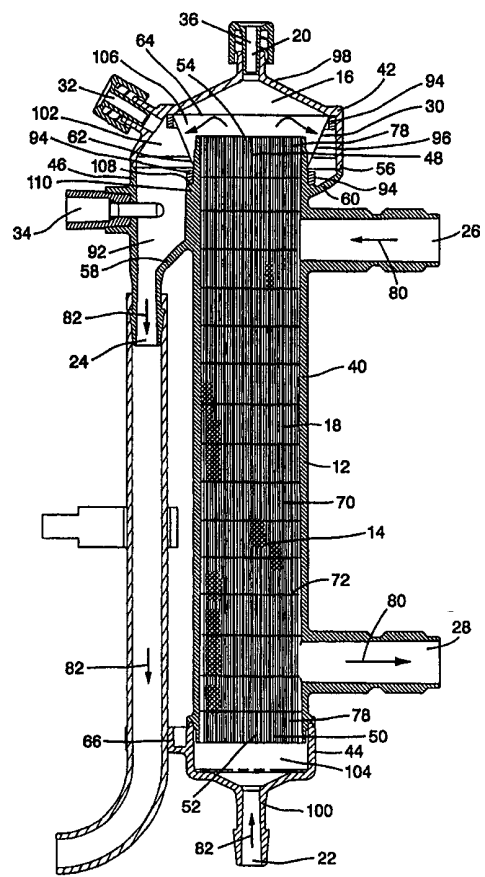

FOR THE PURPOSES OF INFORMATION ONLY

Codes used to identify States party to the PCT on the front pages of pamphlets publishing international applications under the PCT.

AL	Albania	ES	Spain	LS	Lesotho	SI	Slovenia
AM	Armenia	FI	Finland	LT	Lithuania	SK	Slovakia
AT	Austria	FR	France	LU	Luxembourg	SN	Senegal
AU	Australia	GA	Gabon	LV	Latvia	SZ	Swaziland
AZ	Azerbaijan	GB	United Kingdom	MC	Monaco	TD	Chad
BA	Bosnia and Herzegovina	GE	Georgia	MD	Republic of Moldova	TG	Togo
BB	Barbados	GH	Ghana	MG	Madagascar	TJ	Tajikistan
BE	Belgium	GN	Guinea	MK	The former Yugoslav Republic of Macedonia	TM	Turkmenistan
BF	Burkina Faso	GR	Greece	ML	Mali	TR	Turkey
BG	Bulgaria	HU	Hungary	MN	Mongolia	TT	Trinidad and Tobago
BJ	Benin	IE	Ireland	MR	Mauritania	UA	Ukraine
BR	Brazil	IL	Israel	MW	Malawi	UG	Uganda
BY	Belarus	IS	Iceland	MX	Mexico	US	United States of America
CA	Canada	IT	Italy	NE	Niger	UZ	Uzbekistan
CF	Central African Republic	JP	Japan	NL	Netherlands	VN	Viet Nam
CG	Congo	KE	Kenya	NO	Norway	YU	Yugoslavia
CH	Switzerland	KG	Kyrgyzstan	NZ	New Zealand	ZW	Zimbabwe
CI	Côte d'Ivoire	KP	Democratic People's Republic of Korea	PL	Poland		
CM	Cameroon	KR	Republic of Korea	PT	Portugal		
CN	China	KZ	Kazakstan	RO	Romania		
CU	Cuba	LC	Saint Lucia	RU	Russian Federation		
CZ	Czech Republic	LI	Liechtenstein	SD	Sudan		
DE	Germany	LK	Sri Lanka	SE	Sweden		
DK	Denmark	LR	Liberia	SG	Singapore		
EE	Estonia						

CARDIOPLEGIA HEAT EXCHANGER

BACKGROUND OF THE INVENTION

1. Field of the Invention

This invention is related generally to the field of heat exchangers
5 for use in the medical field. In particular, it relates to heat exchangers for
use in cardioplegia fluid delivery.

2. Description of the Related Art

During open heart surgery it is desirable to arrest the heart
10 allowing the surgeon to perform delicate medical procedures. The
heart may be protected during open heart surgery by using a cold
cardioplegia fluid. The cardioplegia fluid typically consists of a
crystalloid chemical solution along with blood so that the heart can
continue to receive nutrients and oxygen during the process. The cold
15 cardioplegia fluid is delivered to the heart at a temperature of typically
0 to 15 degrees C. The cardioplegia fluid is cooled by using a
cardioplegia heat exchanger.

Prior to use, the cardioplegia system is filled with an isotonic
priming solution to remove air from the system. The priming solution
20 needs to be kept to a minimum to reduce the dilution of the patient's
blood system by the priming fluid. Therefore it is beneficial to reduce the
overall priming volume of the cardioplegia heat exchanger as well as the
attached fluid lines.

The cardioplegia fluid may at times contain gas bubbles
25 introduced into the fluid left over from the priming process, through
turbulence, or driven off during the heat exchange process. These gas
bubbles need to be removed from the cardioplegia fluid before reaching
the patient. Some cardioplegia heat exchangers include a bubble trap to
accumulate and release these gas bubbles from the cardioplegia fluid. In

addition, some bubble traps position a microporous screen in the fluid flow path to help separate gas bubbles from the cardioplegia fluid.

A new and useful cardioplegia heat exchanger is needed that overcomes the problems associated with conventional cardioplegia heat exchangers by providing a safer, easier to manufacture, easier to use,
5 and compact cardioplegia heat exchanger.

In general, prior art cardioplegia heat exchangers either completely lack a bubble trap, or the bubble trap design is inadequate. Design problems found in existing bubble traps include: a) excessive
10 surfaces in the bubble trap allowing gas bubbles to accumulate along various edges and surfaces, particularly substantially horizontal surfaces; b) inadequate entrapped gas separation from the fluid flow path allowing the entrapped gas to be drawn down the cardioplegia fluid outlet line; c) inability to remove gas bubbles downstream of the screen; d) abrupt
15 changes in flow direction causing possible air entrapment due to turbulence or causing damage to the red blood cells, particularly in the drain area; and e) off center air release ports causing inefficient use of bubble trap priming volume and creating additional gas bubble accumulating surfaces.

20 Some cardioplegia heat exchangers do not provide for an optional screen, particularly hollow tube heat exchangers. Hollow tube heat exchangers require potting and trimming during manufacture. These processes do not allow parts that extend beyond the end of the heat exchanger to be fluidly sealed with the potting compound to the heat
25 exchanger due to the trimming process. In addition, the trimming process leaves the edges of the heat exchanger uneven making a fluid tight seal difficult to obtain at the exit of the heat exchanger. The trimming process also creates an inconsistent length in the heat exchanger creating an inconsistent distance between the end of the heat exchanger and the

bubble trap cap, to which the opposite end of the screen would need to be attached in a fluid tight manner.

Another problem is that use of a screen reduces the volume of the bubble separation chamber of the bubble trap. Any gas bubbles that are introduced into or are separated from the fluid downstream of the screen cannot be easily removed. This may particularly occur if the bubble trap fills with gas or air to a point below the level of the screen. The fluid beneath the air or gas seeks a level top surface causing the air or gas to fill part of the area below the screen trapping the air below the screen. The gas bubbles cannot pass back through the wet screen to the air release port. Therefore, gas bubble clearing is limited to the volume upstream of the screen.

Another problem is that some cardioplegia heat exchangers use materials that are not biocompatible requiring special coatings causing increased cost of manufacture.

Another problem is that gas bubbles may become entrapped in the entrance of cardioplegia heat exchangers upstream of the heat exchange tubes. Hollow heat exchanger tubes have small openings, therefore, the gas bubbles may be too large to enter the hollow tubes causing gas bubbles to accumulate and block the entrances to the hollow tubes reducing heat exchanger efficiency and increasing the pressure drop of the cardioplegia fluid.

Another problem is that the flow through cardioplegia heat exchangers may be turbulent to increase heat exchange efficiency. However, turbulent flow causes gas bubbles to be entrapped in the fluid and also causes sheer forces in the cardioplegia fluid causing hemolysis.

Another problem with cardioplegia heat exchangers is that attachment of fluid lines may be confusing, particularly if the flow paths are not easily apparent.

Another problem is cardioplegia heat exchangers may not be ergonomically designed, particularly long or large cardioplegia heat exchangers. Operating rooms continue to be crowded with equipment, long or bulky heat exchangers take up valuable space as well as require
5 longer fluid lines increasing the necessary priming volume of the cardioplegia delivery system.

SUMMARY OF THE INVENTION

It is an object of the heat exchanger in accordance with the
10 present invention to solve the problems outlined above that have heretofore inhibited the successful temperature control of cardioplegia fluid.

More particularly, the device in accordance with the present invention provides for a safer, cost effective, easier to use, compact, heat
15 exchanger.

The unique device in accordance with the present invention broadly includes a hollow casing with a heat exchanger and a bubble trap. The device has blood inlet and outlet ports, water inlet and outlet ports and an air release port. The device has a plurality of hollow heat
20 exchange tubes potted within the heat exchanger. The bubble trap is located at the top end of the heat exchanger and extends annularly about and partially below the blood outlet end of the heat exchanger.

The device may also have a bubble trap with a downwardly sloping bottom wall.

25 The device also provides for an optional microporous screen positioned in the bubble trap.

The device may also provide an air release port positioned downstream of the microporous screen.

The device may also provide a temperature port and a pressure
30 monitor port.

The device may also include an air bolus release port upstream of the heat exchanger portion.

The plurality of hollow heat exchange tubes may be knitted together in a substantially parallel spaced apart relationship forming
5 layers of stacked substantially parallel plies, thereby formed into a hollow tube mat and a heat exchanger bundle.

The bubble trap may have a vertical cross sectional area increasing towards the blood outlet and a drain horizontal cross sectional area decreasing towards the blood outlet.

10 One advantage of the present invention is that the device provides improved gas separation from the cardioplegia fluid while maintaining low priming volume. The present invention provides an upward cardioplegia flow pattern towards the air release port helping gas bubbles migrate to the top of the bubble trap. The present invention provides a centrally
15 located air release port directly over the blood outlet end of the heat exchanger which provides more efficient use of priming volume and reduces unnecessary surfaces. The inlet water port and outlet water port are both located below the bubble trap to allow the air release port to be located directly over the blood outlet end of the heat exchanger and
20 creates a larger open cross sectional area.

The present invention also provides a rapid reduction in flow rate as the cardioplegia fluid exits the heat exchanger and enters the bubble trap. The ratio of the open cross sectional area to the effective heat
25 exchanger cross sectional area of from about 8.1 to about 17.0 provides improved gas separation. The present invention also provides a larger drain cross sectional area for gas bubbles to float upward to the top of the bubble trap as the cardioplegia fluid flows downward. The ratio of the drain cross sectional area to the effective heat exchanger cross sectional
30 area of from about 3.6 to about 11.8 provides improved separation of the gas bubbles from the cardioplegia fluid. The present invention also

provides a ratio of the open cross sectional area to the drain cross sectional area of about 1.4 to about 2.3 which provides a smooth transition of flow from the open area to the drain.

5 The location of the bubble trap portion above, around, and partially beneath the blood outlet end of the heat exchanger portion provides improved gas separation while maintaining low prime volume. The large open cross sectional area due in part to the lack of obstructions possibly caused by heat exchanger tubes extending through the bubble trap in combination with the large drain cross sectional area
10 due in part to the annular channel circumscribing the heat exchanger provides improved gas separation while maintaining low prime volume.

The location of the optional screen about the circumference of the heat exchanger below the outlet end of the heat exchanger also improves gas separation while maintaining prime volume. Locating the
15 screen low in the bubble trap provides more bubble trap volume upstream of the screen without increasing priming volume. Providing more volume upstream of the screen allows more time for any gas bubbles to separate from the cardioplegia fluid before the fluid passes through the screen. Providing more volume upstream of the screen also
20 allows a larger air volume without forcing air into the area below the screen. If a large volume of air forces the level of the liquid to a point below the screen, air may become trapped below the screen. Placing the screen low in the bubble trap provides for more air volume before air is forced below the screen.

25 Another advantage is that the device has an easy to see bottom to top cardioplegia fluid flow pattern. The bottom to top flow pattern allows easier use through easier priming and less complicated fluid line attachment. In addition, the present device provides an easy to see flow pattern allowing observation of the fluid path. The ability to observe the
30 fluid allows the detection of gas bubbles before they leave the heat

exchanger allowing easier removal of the gas bubbles before they reach the patient.

Another advantage is that the device reduces the accumulation of gas bubbles along the surfaces of the bubble trap. The present invention limits the surfaces on which gas bubbles may accumulate by providing a bubble trap without additional surfaces caused by either heat exchanger tubes extending through the bubble trap portion or unusually shaped air release passages caused by air release ports located on the side of the bubble trap, or not directly over the heat exchanger. The present invention also limits unnecessary substantially horizontal surfaces by reducing the number of heat exchange tubes and increasing their length thereby reducing the necessary heat exchanger cross sectional area while maintaining heat exchanger efficiency. Configuring the hollow heat exchange tubes into a hollow tube mat and a heat exchanger bundle reduces the number of heat exchange tubes and the heat exchanger cross sectional area needed to provide efficient heat exchange, which reduces unnecessary substantially horizontal surfaces. The reduction in heat exchanger cross sectional area reduces the size of the bubble trap cap thereby reducing horizontal surface area. The smaller bubble trap cap also allows the cap to be a more spherically shaped, which is simpler and more efficient while maintaining low prime volume.

Another advantage is that the device provides for an optional screen. The present invention provides for an optional screen, in particular, a screen adapted for a hollow tube heat exchanger. The present invention overcomes fluid tight attachment problems of previous cardioplegia heat exchangers by attaching the screen at the bottom edge of the bubble trap portion around the outside of the heat exchanger. The outside circumference of the present heat exchanger is provided with an edge to provide a base that provides a fluid tight seal and is also a consistent distance from the point of connection of the top part of the

screen also allowing a consistent fluid tight seal of the top portion of the screen. The device may be easily assembled with or without the screen.

Another advantage is that the device provides a larger volume bubble separation chamber. The location of the screen low in the bubble trap portion increases the volume upstream of the screen for bubble separation. In addition, the bubble trap volume downstream of the screen also provides for the release of gas bubbles due to the post screen air release port. The post screen air release port allows for the easy removal of gas bubbles downstream of the screen.

Another advantage is that the materials used in the device are biocompatible. The present invention uses biocompatible polyurethane heat exchange tubes and other biocompatible materials. These materials are less harmful to the blood in the cardioplegia fluid.

Another advantage is that the device provides for the release of entrapped gas upstream of the heat exchange tubes. The present invention may include an air bolus release port. Entrapped gas bubbles may be released through the air bolus release port increasing safety and improving heat exchange efficiency.

Another advantage is that the bubble trap and drain may provide for less turbulent flow of the cardioplegia fluid particularly as the fluid exits the bubble trap. The device may provide a gradually sloping bubble trap bottom wall to the drain reducing turbulence in the cardioplegia fluid as the fluid exits the bubble trap.

Another advantage is that the device reduces the damage to the blood. Hollow heat exchange tubes minimize the surface area of the heat exchanger, which decreases platelet and fibrinogen aggregation and reduces hemolysis. A gradually sloping bubble trap bottom wall reduces turbulence, which reduces unnecessary shear forces that cause hemolysis.

Another advantage is that the device provides for easy attachment of fluid lines. The device has an easy to follow bottom to top cardioplegia flow pattern and the flow is observable throughout the device. This bottom to top arrangement simplifies the fluid line attachment. The device may also have a blood outlet line clip that holds the blood outlet (cardioplegia fluid) line in a substantially parallel relationship with the blood inlet line making fluid line attachment easier.

Another advantage is that the device provides reduced cost of manufacture. The device uses polyurethane hollow heat exchanger tubes instead of stainless steel parts eliminating the need for special coatings and metal fabrication reducing the cost of manufacture.

Another advantage is that the device is compact in design. The device provides a unique combination of number, length, and size of hollow heat exchanger tubes in combination with a bubble trap that balances the requirements of improved gas bubble separation while maintaining low priming volume and reducing the overall size of the device.

These and other objects and advantages of the present invention will become apparent during the course of the following detailed description and appended claims. The invention may best be understood with reference to the accompanying drawings, wherein an illustrative embodiment is shown.

BRIEF DESCRIPTION OF THE DRAWINGS

Figure 1 is a side view of the assembled device.

Figure 2 is a side cross sectional view of the device.

Figure 3 is an exploded perspective view of the device.

Figure 4 is a side cross sectional view of the main portion of the device.

Figure 5 is a perspective view of the bubble trap cap of the device.

Figure 6 is a side cross sectional view of the bubble trap cap of the device.

Figure 7 is a perspective view of the bottom cap of the device.

Figure 8 is a perspective view of the frame of the screen of the device.

Figure 9 is a perspective view of the screening of the screen of the device.

Figure 10 is a partial view of the hollow tube mat of the device detailing the weft knitting.

Figure 11 is a partial cross sectional view of the heat exchanger bundle of the device.

Figure 12 is a partial cross sectional view of a second embodiment of the device.

Figure 13 is a cross sectional view of the bubble trap portion of the device showing the open cross sectional area.

Figure 14 is a cross sectional view of the bubble trap portion of the device showing heat exchanger cross sectional area.

Figure 15 is a cross sectional view of the bubble trap portion of the device showing the effective heat exchanger cross sectional area.

Figure 16 is a cross sectional view of the bubble trap portion of the device showing the drain cross sectional area.

Figure 17 is a cross sectional view of the device showing the vertical cross sectional area.

25 DETAILED DESCRIPTION OF THE INVENTION

GENERAL ASSEMBLY

Referring to Figs. 1-17, the cardioplegia heat exchanger 10 in accordance with the present invention broadly includes a casing 12, a heat exchanger portion 14, a bubble trap portion 16, a plurality of hollow heat exchange tubes 18, a main air release port 20, a blood inlet port 22,

a blood outlet port 24, an inlet water port 26, and an outlet water port 28. The cardioplegia heat exchanger 10 may also include a screen 30, a post screen air release port 32, a temperature port 34, a pressure monitor port 36, an air bolus release port 38, and a blood outlet line clip
5 66.

THE CASING

Referring particularly to Figures 1 and 2, the casing 12 has a top end 98 and a bottom end 100 and is preferably molded from any plastic
10 or synthetic resin material which is sufficiently rigid and strong upon curing such as polycarbonate, polyester, or other suitable materials. The casing 12 is preferably molded in three parts, a main section 40, a bubble trap cap 42, and a bottom cap 44. The three parts may be assembled and fluidly sealed together to form the casing 12.

15

MAIN SECTION

Referring particularly to Figure 4, the main section 40 has a top end 48 and a bottom end 50 and is generally a hollow cylindrical tube defining the heat exchanger portion 14 and a generally annular ring 60
20 attached to the top end 48 of the main section 40 circumscribing the hollow cylindrical tube defining the bubble trap bottom section 46. The annular ring 60 joins with the bubble trap cap 42 to form an annular channel 102 as shown in Figure 2. The temperature port 34 is an opening defined in the bubble trap bottom section 46, and the inlet and
25 outlet water ports 26, 28 are both openings defined in the side of the main section 40 in the heat exchanger portion 14.

HEAT EXCHANGER PORTION

Referring particularly to Figure 2, the heat exchanger portion 14
30 contains a plurality of hollow heat exchange tubes 18 potted within the

heat exchanger portion 14. The heat exchanger portion 14 has a blood inlet end 52 corresponding to the bottom end 50 of the main section 40 and a blood outlet end 54 corresponding to the top end 48 of the main section 40. The hollow heat exchange tubes 18 are sealed with potting compound 78 at the top end 48 and bottom end 50 of the main section 40. The potting compound 78 forms a fluid seal between the hollow heat exchange tubes 18 and the side of the heat exchanger portion 14 of the casing 12. The potting compound 78 fluidly seals the heat exchange fluid 80 from the cardioplegia fluid 82 at each end 52, 54 of the heat exchanger portion 14. The blood outlet end 54 of the hollow heat exchange tubes 18 are fluidly connected to the bubble trap portion 16 and the blood inlet end 52 of the hollow heat exchange tubes 18 are fluidly connected to the blood inlet port 22 through the blood inlet chamber 104 and the bottom cap 44. The blood outlet end 54 of the heat exchanger portion 14 is designed to extend beyond the top edge 56 of the bubble trap bottom section 46. This allows the potting compound 78 to be easily trimmed away to expose the ends of the hollow heat exchange tubes 18. The heat exchange fluid 80 is preferably water, but may be any suitable heat exchange media. The cardioplegia fluid 82 may be cardioplegia fluid, blood, or a combination of cardioplegia fluid and blood.

HOLLOW HEAT EXCHANGE TUBES

Referring particularly to Figures 2, 10, and 11, the heat exchanger portion 14 includes a heat exchanger bundle 70 comprised of a plurality of hollow heat exchange tubes 18 formed into a hollow tube mat 68 as shown in Fig. 10. The individual hollow heat exchange tubes 18 are preferably formed from a polyurethane resin such as B.F. Goodrich Estane™ 58091.

The hollow heat exchange tubes 18 preferably have an outside diameter of from about 0.025 inches (635 m m) to about 0.040 inches (1016 m m) and most preferably have an outside diameter of 0.033 inches (840 m m). The hollow heat exchange tubes 18 also preferably
5 have a wall thickness of about 0.002 inches (50 m m) to about 0.006 inches (152 m m) and most preferably have a wall thickness of about 0.004 inches (120 m m). The formation of hollow heat exchange tubes 18 from polyurethane rather than stainless steel used in a variety of commercial units is advantageous because of biocompatibility and the
10 flexibility of the polyurethane tubes allows the hollow heat exchange tubes 18 to be formed into a hollow tube mat 68 and a heat exchanger bundle 70. The bundle configuration allows the reduction in surface area of hollow heat exchange tubes 18 needed to provide efficient heat exchange, which thereby reduces prime volume.

15 In addition, while efficiency of the cardioplegia heat exchanger 10 is an important design consideration, it is vital that there is no leakage between the heat exchange fluid 80 and the cardioplegia fluid 82. If the design of the cardioplegia heat exchanger 10 does not provide for a leak-proof seal between the heat exchange fluid 80 and the cardioplegia fluid
20 82, hemolysis of red blood cells will result. The use of polyurethane for the hollow heat exchange tubes 18 instead of stainless steel coils and polyurethane for the end-potting compound 78 provides a leak-proof seal. The compatibility between the polyurethane of the hollow heat exchange tubes 18 and the potting compound 78 thereby greatly
25 increases patient safety and therefore the effectiveness of the product.

To maximize the performance characteristics of the heat exchanger portion 14 as a whole and to reduce prime volume, the present invention utilizes a hollow tube mat 68 which is then wound into a heat exchanger bundle 70.

Hollow heat exchange tubes 18 are weft knitted into a hollow tube mat 68 by a weft knitting machine. A hollow tube mat 68 is a flat, single layer arrangement of substantially parallel hollow heat exchange tubes 18 knitted together in a spaced apart relationship by warp thread means 72, as can be seen in Fig 10. Weft knitting machines are well known in the textile industry and are used extensively to knit fabric and the like. Machines are available from American Liba Inc. (Piedmont, SC) and Karl Mayer Machine Corp. (Greensboro, NC).

Briefly, in constructing the hollow tube mat 68, a single strand of hollow heat exchange tube 18 is fed through a series of tension wheels with the tension preferably set at between 4-6 gms and most preferably at 5 gms. The strand of hollow heat exchange tube 18 is then threaded through a crochet needle positioned over warp thread means 72. Preferably from about 30-42 warp threads and more preferably 35-38 warp threads and most preferably 37 individual multi-stranded warp threads, spaced at a distance of 5 mm, are threaded through the eyelet needles of a warp placing rail. The eyelet needle segments installed on the warp placing rail move up and down, as well as laterally to the left and right.

Referring again to Fig 10, hollow heat exchange tubes 18 are disposed at regular lateral intervals along the entire length of the hollow tube mat 68. Hollow heat exchange tubes 18 are knitted together and maintained substantially parallel to each other by warp thread means 72 running transversely to the hollow heat exchange tubes 18. The warp thread means 72 may be a multi-filament thread or ribbon or hollow fiber tape.

The number of hollow heat exchange tubes 18 per centimeter is preferably from 5.7 to 9.5 tubes per centimeter, and most preferably is about 7.0 tubes per centimeter. It is not necessary for the spacing interval 74 between each hollow tube to be identical so long as it falls

within a range of approximately about 0.175 cm to 0.105 cm. The spacing interval 74 is calculated by measuring the distance between center A and center B of hollow heat exchange tubes 18. In the preferred embodiment the hollow tube mat 68 is continuous.

5 The heat exchanger bundle 70 is obtained by winding the hollow tube mat 68 around itself forming a cylindrical heat exchanger bundle 70. The heat exchanger bundle 70 may be wound by machine. The heat exchanger bundle 70 contains a plurality of layers 77 of plies 76 of the hollow tube mat 68. The heat exchanger bundle 70 preferably contains
10 from about 300 to about 425 and most preferably about 375 hollow heat exchange tubes 18. A hollow tube ply 76 is a single complete revolution of the heat exchanger bundle 70 of cut or continuous layer of the hollow tube mat 68. Successive layers of hollow tube mat 68 form substantially
15 concentric plies 76 of hollow tube mat 68. The individual hollow heat exchange tubes 18 that comprise the plies 76 of the heat exchanger bundle 70 form a pattern of spaced apart interdigitation that allows for the uniform flow of heat exchange fluid thereby increasing heat exchange efficiency.

 As can be seen from Figs 10 and 11, the warp thread means 72
20 acts as a spacer between each parallel hollow heat exchanger tube 18 in the hollow tube mat 68, each ply 76, and all layers of plies 76 that comprise the heat exchanger bundle 70. The advantage of this uniformed spaced apart relationship between the individual hollow heat exchange tubes 18, each successive ply 76 and the layers in the heat
25 exchanger bundle 70, as seen in Fig 11, is to control the distribution of heat exchange fluid 80 so that it is uniform throughout the heat exchanger bundle 70. This uniform fluid flow allows for high heat exchange efficiency.

30 WATER PORTS

Referring particularly to Figures 2 and 3, the inlet water port 26 and the outlet water port 28 are openings defined in the side of the casing 12 in the heat exchanger portion 14. The inlet and outlet water ports 26, 28 provide openings for a supply of heat exchange fluid 80, which is preferably water, to flow into the heat exchanger portion 14 and contact the outside of the hollow heat exchange tubes 18. Heat is thereby passed through the hollow heat exchange tubes 18 to or from the cardioplegia fluid 82 inside the hollow heat exchange tubes 18. The inlet water port 26 is preferably located towards the top end 48 of the main section 40 on the opposite side of the main section 40 as the blood outlet port 24. The outlet water port 28 is preferably located towards the bottom end 50 of the main section 40 also on the opposite side of the main section 40 as the blood outlet port 24. The inlet and outlet water ports 26, 28 are preferably located below the blood outlet end 54 of the heat exchanger portion 14. The inlet and outlet water ports 26, 28 are preferably Hansen type connectors or suitable equivalents.

BUBBLE TRAP PORTION

Referring particularly to Figures 2, 5, and 6, the bubble trap portion 16 is defined by the bubble trap bottom section 46 of the main section 40 and the bubble trap cap 42. The bubble trap portion 16 is shaped to allow the escape and release of air or gas from the cardioplegia fluid 82 through the main air release port 20 and the post screen release port 32. The main air release port 20 is an opening located at the top end of the bubble trap portion 16 which corresponds to the top end of the bubble trap cap 42 and the top end 98 of the casing 12. Preferably the main air release port 20 is located directly over blood outlet end 54 of the heat exchanger portion 14, most preferably in the center of the bubble trap cap 42. The main air release port 20 may also be located to the side of the bubble trap portion 16, not directly over the

blood outlet end 54 of the heat exchanger portion 14. This main air release port 20 may also function as a pressure monitor port 36 or the pressure monitor port 36 may be provided as a separate opening in the bubble trap portion 16. Preferably, the shape and size of the bubble trap portion 16 is designed so that the flow of cardioplegia fluid 82 slows as it exits the blood outlet end 54 of the heat exchanger portion 14 so that air or gas in the cardioplegia fluid 82 can rise to the top of the fluid stream instead of being carried away in the fluid stream. Preferably, the blood outlet end 54 of the heat exchanger portion 14 extends above the bubble trap bottom wall 58 creating a drain 92. This allows the cardioplegia fluid 82 to flow downwardly while the air or gas in the fluid flows upwardly. The bubble trap bottom wall 58 is preferably sloped gradually downward to the blood outlet port 24. The bubble trap bottom wall 58 may have a constant downward slope or preferably, the downward slope of bubble trap bottom wall 58 gradually increases as it nears the blood outlet port 24. However, the bubble trap bottom wall 58 may also be substantially horizontal as shown in Figure 12. The bubble trap portion 16 preferably extends annularly around and partially below the blood outlet end 54 of the heat exchanger portion 14 forming an annular channel 102. The bubble trap portion 16 preferably creates a dome like area over and surrounding the blood outlet end 54 of the heat exchanger portion 14.

Referring particularly to Figures 13, 14, 15, 16, and 17, the bubble trap portion 16 has an open cross sectional area 84, a heat exchanger cross sectional area 86, an effective heat exchanger cross sectional area 88, a drain cross sectional area 90, and a vertical cross sectional area 91. As shown in Figure 13, the open cross sectional area 84 is the largest cross sectional area that the cardioplegia fluid 82 flows through after leaving the heat exchanger portion 14. In the present invention, the open cross sectional area 84 is the horizontal cross sectional area of the inside of the bubble trap portion 16. As shown in Figure 14, the heat

exchanger cross sectional area 86 is the horizontal cross sectional area of the heat exchanger portion 14. In the present invention, the heat exchanger cross sectional area 86 is the horizontal cross sectional area of the outside diameter of the heat exchanger portion 14. As shown in

5 Figure 15, the effective heat exchanger cross sectional area 88 is the total fluid opening area of heat exchanger portion 14 at the blood outlet end 54 of the heat exchanger portion 14. In the present invention, the effective heat exchanger cross sectional area 88 is the total area of the horizontal cross sectional area of the inside diameter of the plurality of

10 hollow heat exchange tubes 18 at the blood outlet end 54 of the heat exchanger portion 14. As shown in Figure 16, the drain cross sectional area 90 is the horizontal cross sectional area of the bubble trap portion 16 where the cardioplegia fluid 82 is flowing downwardly before the cardioplegia fluid 82 exits the cardioplegia heat exchanger 10 through

15 the blood outlet port 24. In the present invention, the drain cross sectional area 90 is the horizontal cross sectional area of the bubble trap portion 16 circumscribing the heat exchanger portion 14. The drain cross sectional area 90 in the present invention may vary from a maximum at the blood outlet end 54 of the heat exchanger portion 14 to a minimum at

20 the blood outlet port 24. The drain cross sectional area 90 at the blood outlet end 54 of the heat exchanger portion 14 for the present invention is the open cross sectional area 84 minus the heat exchanger cross sectional area 80. The drain cross sectional area 90 at the blood outlet port 24 is the cross sectional area of the blood outlet port 24.

25 As shown in Figure 17, the vertical cross sectional area 91 is the vertical cross sectional area of one side of the bubble trap portion 16. The vertical cross section is taken on a vertical plane through the center of the heat exchanger portion 14, and includes the area from the outside of the heat exchanger portion 14 to the inside of the bubble trap portion

30 16 and from the blood outlet end 54 of the heat exchanger portion 14 to

the bubble trap bottom wall 58 or the shoulder of the blood outlet port 24. The vertical cross sectional area 91 preferably increases towards the blood outlet port 24. The vertical cross sectional area preferably has a maximum 91a and a minimum 91b.

5 The open cross sectional area 84 is preferably from about 1.70 sq. in. to about 2.55 sq. in. and most preferably about 2.12 sq. in. The heat exchanger cross sectional area 86 is preferably from about 0.77 sq. in. to about 0.95 sq. in. and most preferably about 0.86 sq. in. The effective heat exchanger cross sectional area 88 is preferably from about
10 0.15 sq. in. to about 0.21 sq. in. and most preferably about 0.18 sq. in. The drain cross sectional area 90 is preferably from about 1.78 sq. in. to about 0.76 sq. in. and most preferably about 1.27 sq. in. The vertical cross sectional area 91 at the blood outlet port 24 is preferably from about 0.10 sq. in. to about 0.65 sq. in. and most preferably about 0.57
15 sq. in. The vertical cross sectional area 91 at the point farthest away from the blood outlet port 24 is preferably from about 0.1 sq. in. to about 0.65 sq. in. and most preferably about 0.12 sq. in. The ratio of the maximum vertical cross sectional area 91 to the minimum vertical cross sectional area 91 is preferably about 1.0 to about 6.5 and most
20 preferably about 5.4.

 The ratio of the open cross sectional area 84 to the effective heat exchanger cross sectional area 88 is preferably about 8.1 to about 17.0 and most preferably about 11.8. The ratio of the drain cross sectional area 90 to the effective heat exchanger cross sectional area 88 is
25 preferably about 3.6 to about 11.9 and most preferably about 7.0. The ratio of the open cross sectional area 84 to the drain cross sectional area 90 is preferably about 1.4 to about 2.3 and most preferably about 1.7.

 The increase in cross sectional area from the heat exchanger portion 14 to the bubble trap portion 16 causes the fluid to slow as it
30 flows through the bubble trap portion 16, allowing better release of air or

gas from the fluid. The bubble trap portion 16 has a blood separation chamber 106 that has a volume of about 25 ml. The blood separation chamber 106, for the present invention, includes the entire volume of the bubble trap portion 16. If a screen 30 were included without a post screen air release port 32 then the blood separation chamber 106 would be the volume of the bubble trap portion 16 upstream of the screen 30. The bubble trap portion 16 has a prime volume of preferably from about 20 ml to about 50 ml and most preferably about 25 ml and the total prime volume of the cardioplegia heat exchanger is preferably from about 40 ml to about 70 ml and most preferably about 45 ml.

The blood outlet port 24 is an opening defined in the bubble trap portion 16 of the casing 12. The blood outlet port 24 is preferably located in the bubble trap bottom wall 58 of the bubble trap portion 16. The bubble trap bottom wall 58 and the sides of the bubble trap portion 16 preferably gradually slope into a downwardly extending blood outlet port 24. The blood outlet port 24 is preferably a standard connection port for connecting blood or cardioplegia lines.

The bubble trap portion 16 preferably defines a temperature port 34. The temperature port 34 is preferably located just above the blood outlet port 24 in the side of the bubble trap portion 16, preferably in the bubble trap bottom section 46. The temperature port 34 is preferably a standard YSI 400 temperature probe.

The bubble trap portion 16 preferably defines a post screen air release port 32. The post screen air release port 32 is an opening located preferably in the side of the bubble trap cap 42 after or below the top of the screen 30 in the cardioplegia fluid flow path. The post screen air release port 32 provides an escape route for entrapped air in the cardioplegia fluid 82.

The bubble trap bottom section 46 is preferably integrally molded with the main section 40. However, the bubble trap bottom section 46

could be attached to the main section 40 by adhesive, sonic welding or other attachment means.

BOTTOM CAP

5 Referring particularly to Figures 2 and 7, the bottom cap 44 fluidly connects the blood inlet end 52 of the heat exchanger portion 14 to the blood inlet port 22. The blood inlet port 22 is an opening defined in the casing 12 and preferably is a standard sized connection for attachment to blood or cardioplegia fluid lines. The bottom cap 44 and the blood inlet
10 end 52 of the heat exchanger portion 14 define a blood inlet chamber 104.

The bottom cap 44 may also define an air bolus release port 38 in the side of the bottom cap 44. The air bolus release port 38 allows the release of air entrapped in the cardioplegia fluid 82 inside the blood inlet
15 chamber 104. As cardioplegia fluid 82 flows from the blood inlet port 22 to the blood inlet end 52 of the heat exchanger portion 14 and hollow heat exchange tubes 18, air bubbles or bolus become trapped in the blood inlet chamber 104, particularly along the bottom edge of the heat exchanger portion 14 at the entrance to the hollow heat exchange tubes
20 18. The air bolus release port 38 allows the release of the air bolus by opening the air bolus release port 38 and releasing the built-up gas or air.

The bottom cap 44 may also include a blood outlet line clip 66. The blood outlet line clip 66 may be a C-shaped clip integrally molded
25 with the bottom cap 44 for removably holding a blood outlet (cardioplegia fluid) line. The blood outlet line clip 66 is vertically aligned with the blood outlet port 24 providing easier access to the blood or cardioplegia fluid lines.

30 SCREEN

Referring particularly to Figures 3, 8, and 9, the cardioplegia heat exchanger 10 may also preferably include a screen 30. The screen 30 is comprised of a frame 94 and screening 96. The screening 96 is microporous, with preferably from about 50 to about 150 micron and most preferably about 105 micron openings. The screening 96 is preferably constructed of polyester. The frame 94 is preferably constructed of a polyethylene or polypropylene.

The screen 30 has the shape of a truncated cone with a narrow end 62 and a wide end 64. The screen 30 is located in the bubble trap portion 16 and provides a screened barrier between the blood outlet end 54 of the heat exchanger portion 14 and the blood outlet port 24.

Referring particularly to Figure 2, the screen 30 is positioned with the narrow end 62 of the screen 30 circumscribing the outside of heat exchange portion 14 below the blood outlet end 54 and above the bubble trap bottom wall 58. The screen 30 is positioned with the wide end 64 of the screen 30 contacting the top of the bubble trap portion 16 at the bubble trap cap 42 and the top end 98 of the case 12. The screen 30 is located at least partially below the blood outlet end 54 of the heat exchanger portion 14. The screen 30 is located at least partially below the blood outlet end 54 of the heat exchanger portion 14 allowing the blood to flow downwardly through the screen 30. The screen 30 is located at least partially in the drain 92. The drain 92 being the area of the bubble trap below the blood outlet end 54 of the heat exchanger portion 14.

The screen 30 is positioned on a base 108. As shown in Figures 3 and 4, the base 108 is defined by an edge 110 circumscribing the heat exchanger portion 14, preferably just above the bubble trap bottom wall 58. The base 108 and edge 110 provide a surface upon which the narrow end 62 of the screen 30 may be fluidly sealed and that may be manufactured with a consistent distance from the top end 98 of the

casing 12 so that the wide end 64 of the screen 30 may be fluidly sealed to the top of the bubble trap portion 14.

The narrow end 62 of the screen 30 also has flattened surfaces 112 along the inside circumference of the narrow end 62 designed to
5 mate with similar mating surfaces 114 along the outside circumference of the heat exchanger portion 14 as shown in Figure 3. The flattened surfaces 112 and the mating surfaces 114 provide a more stable joint sealing surface and keep the screen from rotating or moving.

10 IN OPERATION

Referring particularly to Figure 2, in operation cardioplegia fluid 82 flows into the cardioplegia heat exchanger 10 through the blood inlet port 22, into the blood inlet chamber 104, passing through the bottom cap 44, into the hollow heat exchange tubes 18, out the blood outlet end 54 of
15 the heat exchanger portion 14, into the bubble trap portion 16, into the drain 92 and through the screen 30, and out the blood outlet port 24. Heat exchange fluid 80 flows into the inlet water port 26 into the heat exchanger portion 14 circulating about the outside of the hollow heat exchange tubes 18, and out of the outlet water port 28. As the heat
20 exchange fluid 80 contacts the hollow heat exchange tubes 18 heat is transferred to the heat exchange fluid 80 from the cardioplegia fluid 82 cooling the cardioplegia fluid 82 as needed. Heat may also be transferred to the cardioplegia fluid 82 from the heat exchange fluid 80 to heat the cardioplegia fluid 82 as needed.

25 Although the description of the preferred embodiment has been presented, it is contemplated that various changes, including those mentioned above, could be made without deviating from the spirit of the present invention. It is therefore desired that the present embodiment be considered in all respects as illustrative, not restrictive, and that

reference be made to the appended claims rather than to the foregoing description to indicate the scope of the invention.

CLAIMS

1. A heat exchanger comprising:
 - a) a hollow casing having a top end and a bottom end, said hollow casing defining a heat exchanger portion and a bubble trap portion;
 - b) a plurality of hollow heat exchange tubes potted within said heat exchanger portion, said heat exchanger portion having a blood inlet end and a blood outlet end;
 - c) said bubble trap portion defined at said top end of said hollow casing, said bubble trap portion defining an air release port and a blood outlet port, said bubble trap portion extending annularly around and partially below said blood outlet end of said heat exchanger portion;
 - d) said hollow casing further defining a blood inlet port at said bottom end; and
 - e) said hollow casing further defining an inlet water port and an outlet water port.
2. The heat exchanger of claim 1 wherein said bubble trap portion has a downwardly sloping bottom wall connected to said blood outlet port.
3. The heat exchanger of claim 2 wherein said bubble trap portion decreases in horizontal cross sectional area towards said blood outlet port.
4. The heat exchanger of claim 3 wherein said bubble trap portion has a vertical cross sectional area, said vertical cross sectional area increasing towards said blood outlet port.

5. The heat exchanger of claim 4 wherein said vertical cross sectional area has a maximum vertical cross sectional area and a minimum cross sectional area, said maximum and minimum having a ratio of from about 1.0 to about 6.5.
- 5
6. The heat exchanger of claim 5 wherein said maximum and minimum have a ratio of about 5.4.
7. The heat exchanger of claim 1 wherein said bubble trap portion has
10 an open cross sectional area and an effective heat exchanger cross sectional area, wherein a ratio of said open cross sectional area to said effective heat exchanger cross sectional area is from about 8.1 to about 17.0.
- 15 8. The heat exchanger of claim 7 wherein said ratio of said open cross sectional area to said effective heat exchanger cross sectional area is about 11.8.
9. The heat exchanger of claim 1 wherein said bubble trap portion has
20 an open cross sectional area and a drain cross sectional area, wherein a ratio of said open cross sectional area to said drain cross sectional area is from about 1.4 to about 2.3.
10. The heat exchanger of claim 9 wherein said ratio of said open cross
25 sectional area to said drain cross sectional area is about 1.7.
11. The heat exchanger of claim 1 wherein said bubble trap portion has a drain cross sectional area and an effective heat exchanger cross sectional area, wherein a ratio of said drain cross sectional area to said

effective heat exchanger cross sectional area is from about 3.6 to about 11.8.

12. The heat exchanger of claim 11 wherein said ratio of said drain
5 cross sectional area to said effective heat exchanger cross sectional area is about 7.0.

13. The heat exchanger of claim 1 wherein said bubble trap portion has
a drain cross sectional area, an effective heat exchanger cross sectional
10 area, and an open cross sectional area; wherein a ratio of said drain cross sectional area to said effective heat exchanger cross sectional area is from about 3.6 to about 11.8, a ratio of said open cross sectional area to said drain cross sectional area is from about 1.4 to about 2.3, and a ratio of said open cross sectional area to said effective heat
15 exchanger cross sectional area is from about 8.1 to about 17.0.

14. The heat exchanger of claim 13 wherein said ratio of said drain
cross sectional area to said effective heat exchanger cross sectional
area is about 7.0, said ratio of said open cross sectional area to said
20 drain cross sectional area is about 1.7, and said ratio of said open cross sectional area to said effective heat exchanger cross sectional area is about 11.8.

15. The heat exchanger of claim 1 wherein said bubble trap portion
25 provides for a microporous screen.

16. The heat exchanger of claim 15 wherein said microporous screen is
positioned at least partially below said blood outlet end of said heat
exchanger portion.

17. The heat exchanger of claim 15 further comprising an air release port downstream of said microporous screen.
18. The heat exchanger of claim 1 wherein said air release port is
5 located directly above said blood outlet end of said heat exchanger portion.
19. The heat exchanger of claim 1 wherein said water inlet port and said water outlet port are located below said blood outlet end of said heat
10 exchanger portion.
20. The heat exchanger of claim 1 further comprising a temperature port.
- 15 21. The heat exchanger of claim 1 further comprising a pressure monitor port.
22. The heat exchanger of claim 1 further comprising an air bolus release port upstream of said blood inlet end of said heat exchanger
20 portion.
23. The heat exchanger of claim 1 wherein said plurality of hollow tubes number from about 300 to about 425.
- 25 24. The heat exchanger of claim 1 wherein said plurality of hollow heat exchange tubes are knitted together in a substantially parallel, spaced apart relationship, said plurality of hollow heat exchange tubes forming layers of stacked substantially parallel plies.
- 30 25. A heat exchanger comprising:

- 5
- 10
- 15
- a) a hollow casing having a top end and a bottom end, said hollow casing defining a heat exchanger portion and a bubble trap portion;
 - b) a plurality of hollow heat exchange tubes potted within said heat exchanger portion, said heat exchanger portion having a blood inlet end and blood outlet end;
 - c) said bubble trap portion defined at said top end of said hollow casing, said bubble trap portion defining an air release port and a blood outlet port;
 - d) said hollow casing further defining a blood inlet port at said bottom end; and
 - e) said hollow casing further defining an inlet water port and an outlet water port; and
 - f) a microporous screen positioned in said bubble trap portion.

26. The heat exchanger of claim 25 further comprising an air release port downstream of said microporous screen.
- 20 27. The heat exchanger of claim 25 wherein said microporous screen is positioned at least partially below said blood outlet end of said heat exchanger portion.
- 25 28. The heat exchanger of claim 25 further comprising a temperature port.
29. The heat exchanger of claim 25 further comprising a pressure monitor port.
- 30 30. A heat exchanger comprising:

- a) a hollow casing having a top end and a bottom end, said hollow casing defining a heat exchanger portion and a bubble trap portion;
- 5 b) a plurality of hollow heat exchange tubes potted within said heat exchanger portion, said heat exchanger portion having a blood inlet end and blood outlet end;
- c) said bubble trap portion defined at said top end of said hollow casing, said bubble trap portion defining an air release port and a blood outlet port;
- 10 d) said hollow casing further defining a blood inlet port at said bottom end;
- e) said hollow casing further defining an inlet water port and an outlet water port; and
- 15 f) an air bolus release port upstream of said blood inlet end of said heat exchanger portion.

31. The heat exchanger of claim 30 wherein said plurality of hollow tubes number from about 300 to about 425.

Fig. 1

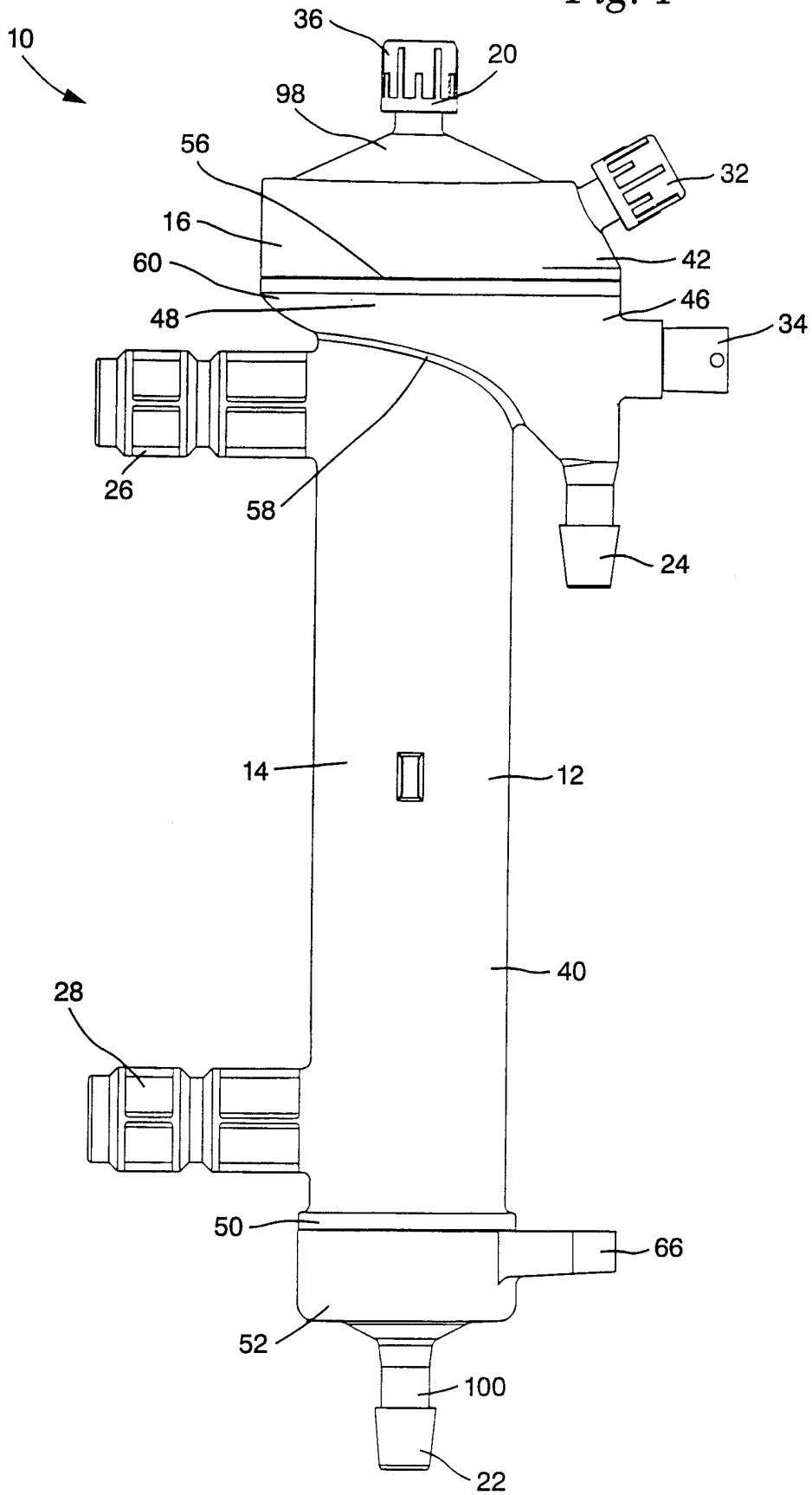
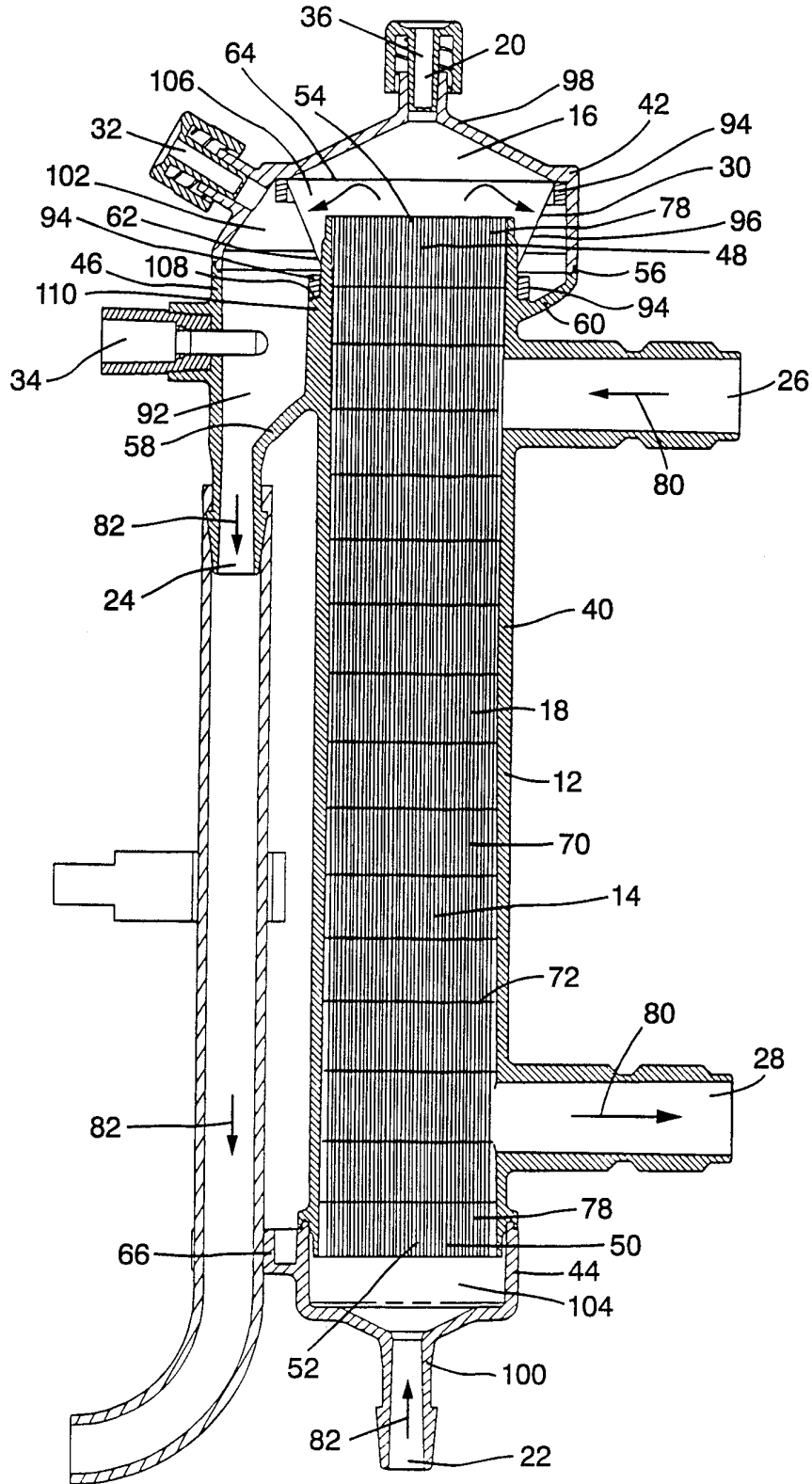

Fig. 2



3/11

Fig. 3

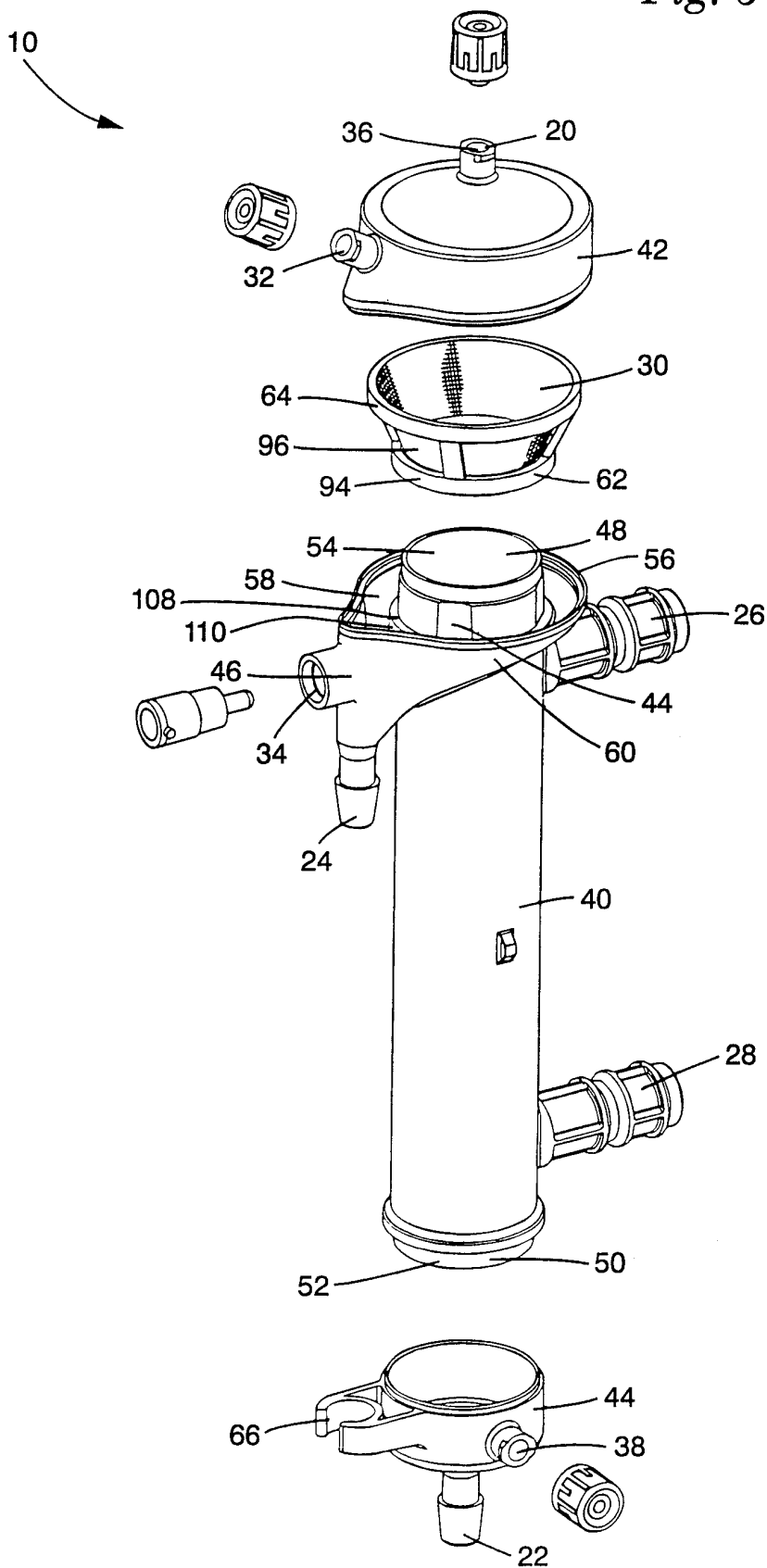

Fig. 4

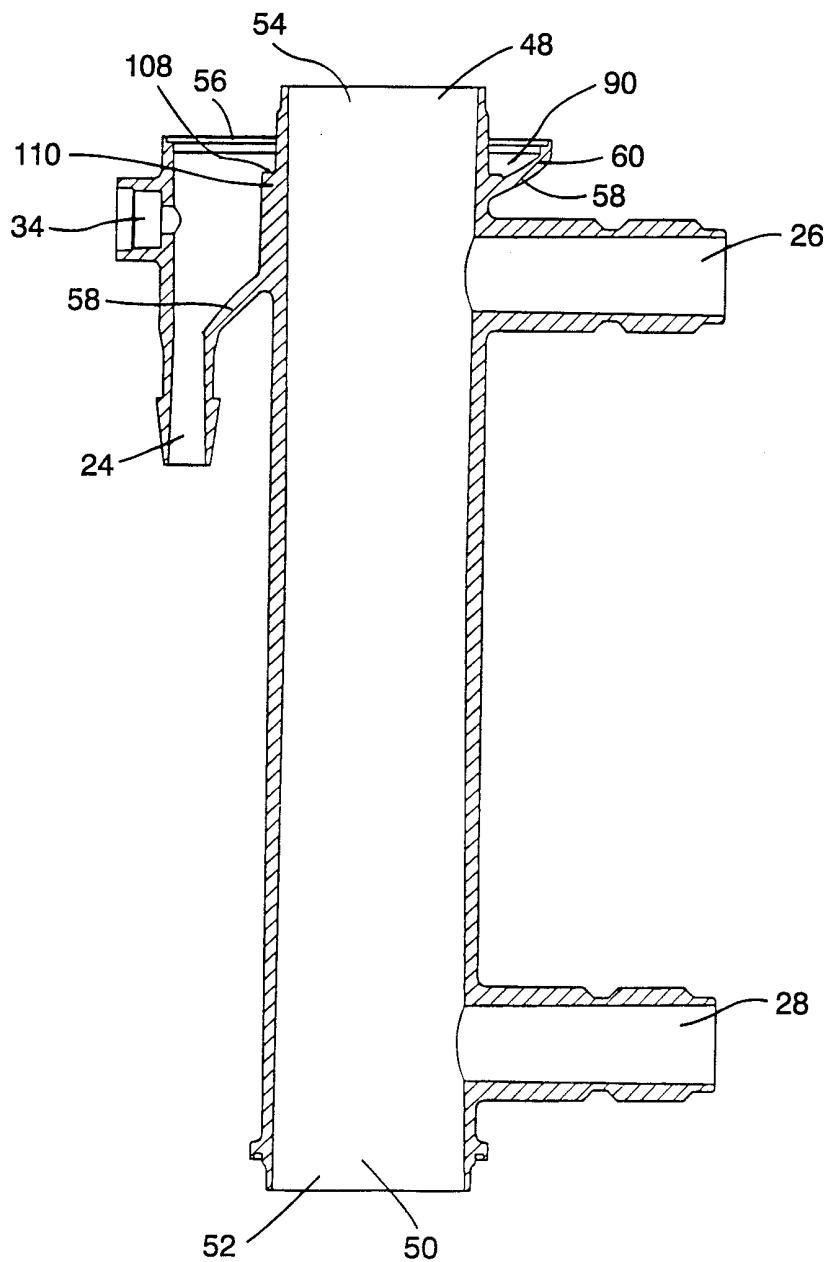

Fig. 5

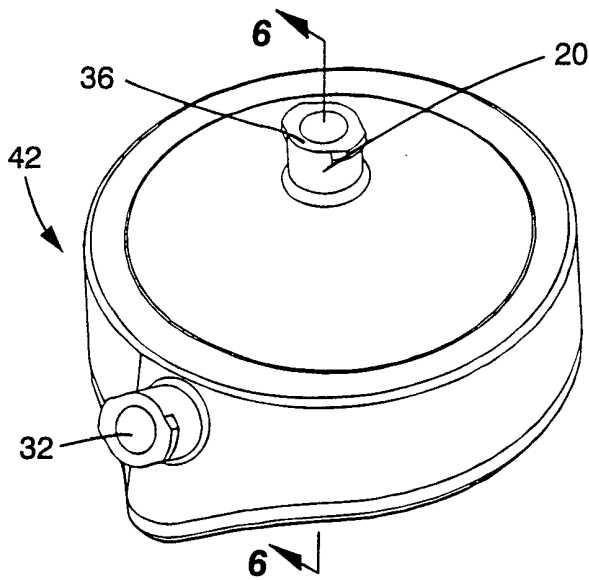

Fig. 6

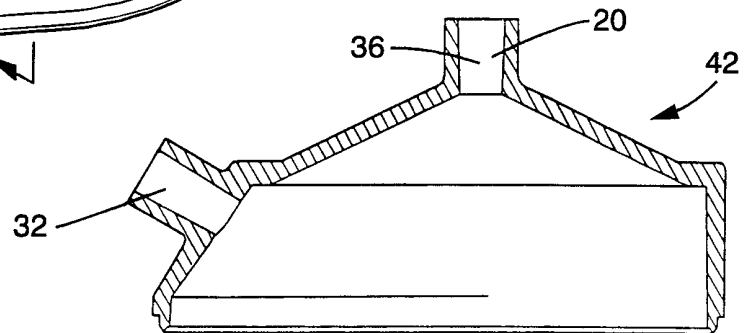
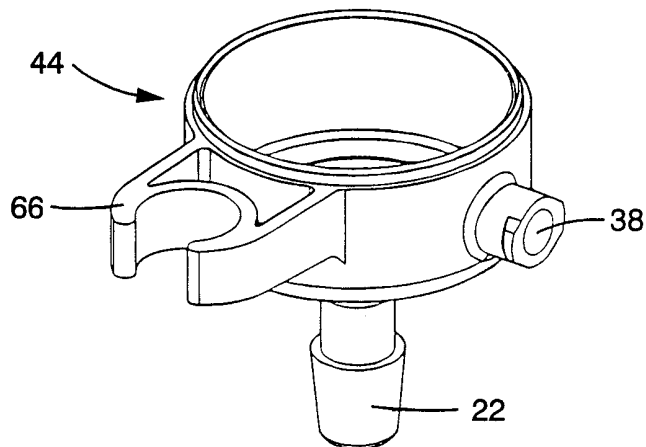

Fig. 7



6/11

Fig. 8

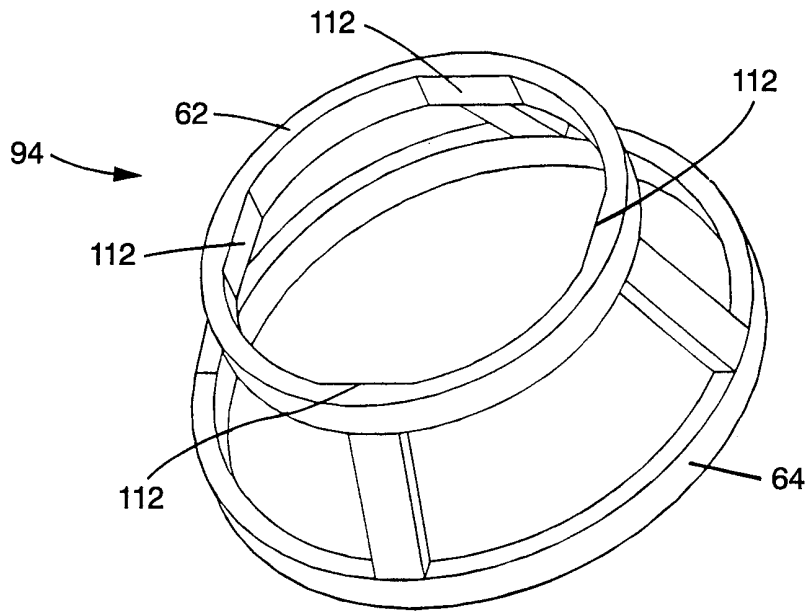
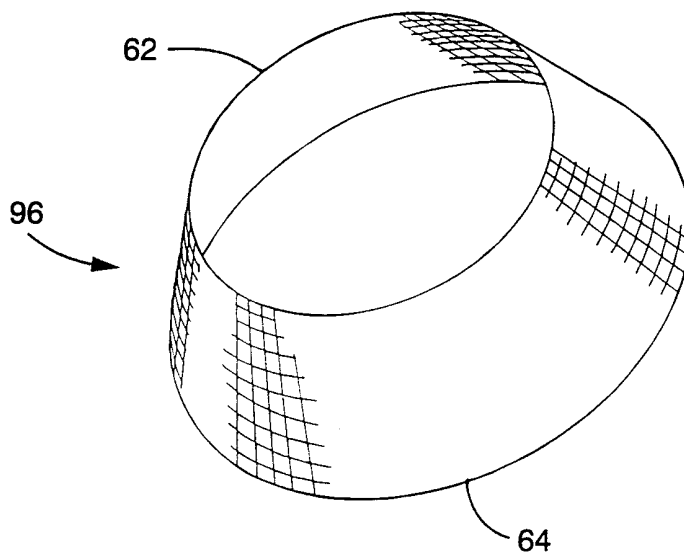

Fig. 9



7/11

Fig. 10

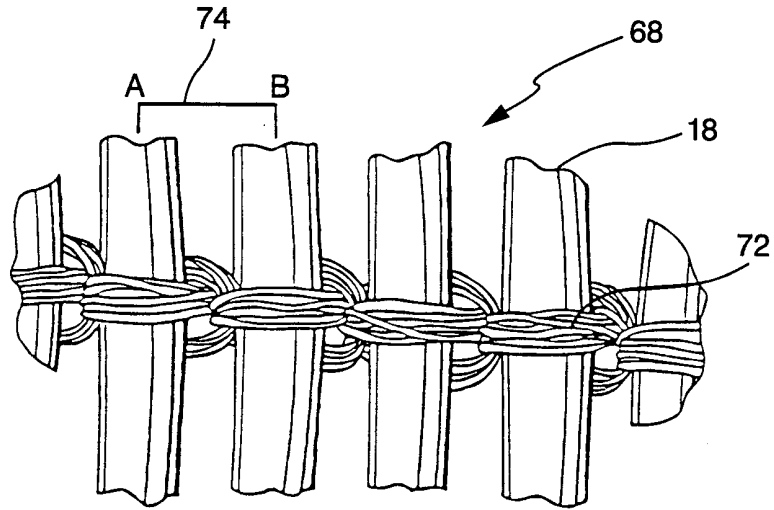

Fig. 11

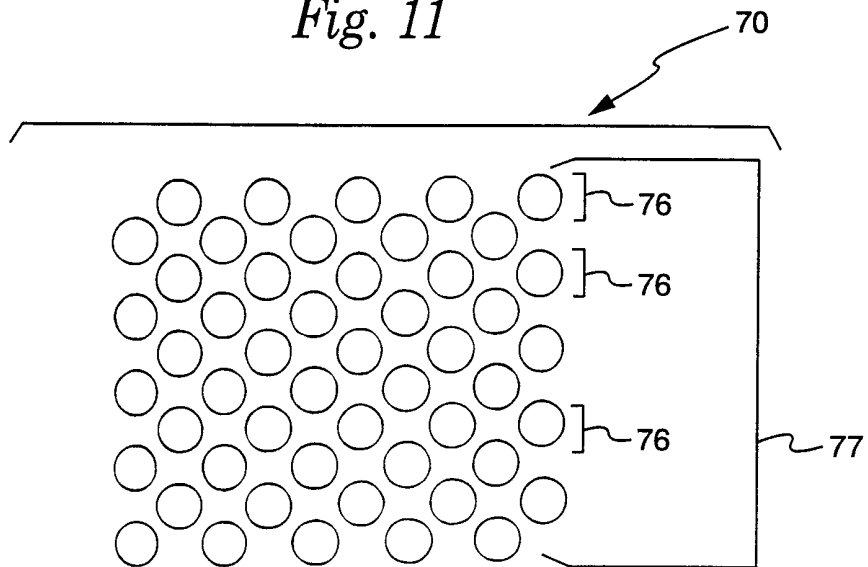
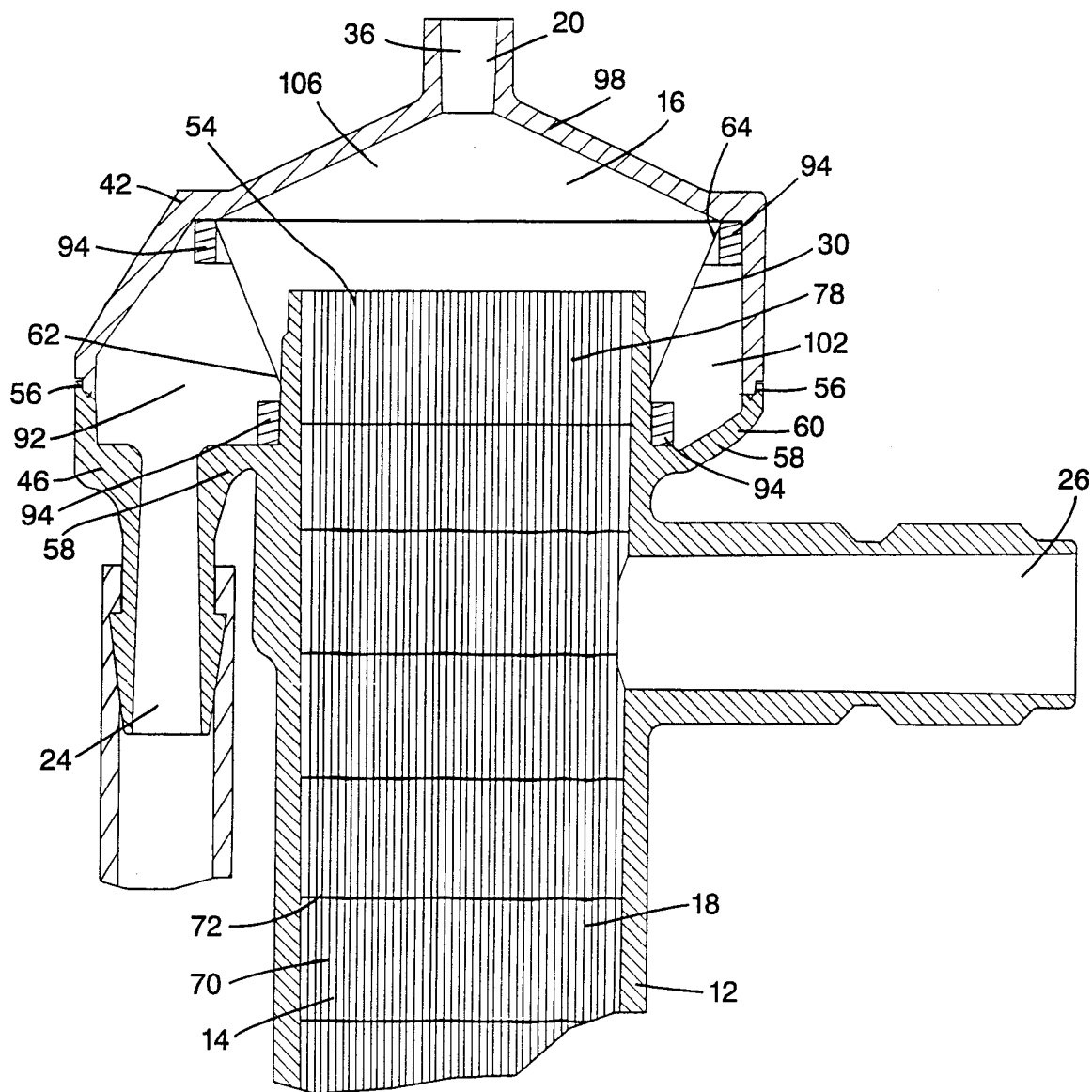

Fig. 12



9/11

Fig. 13

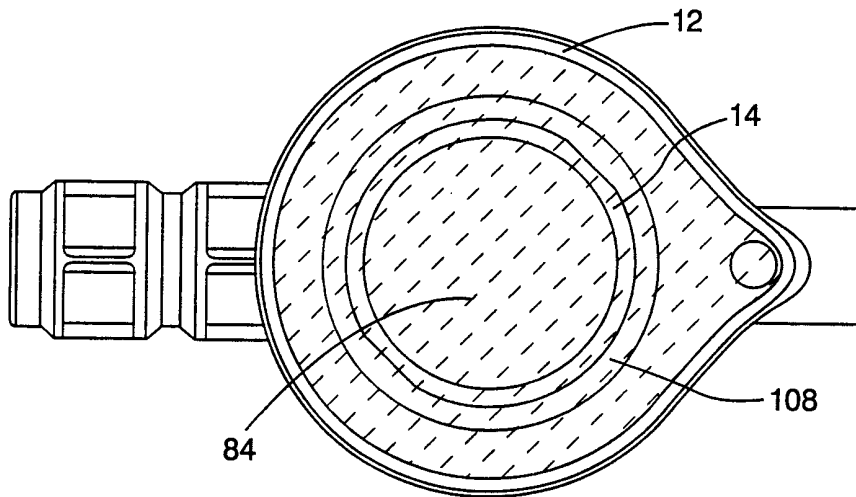
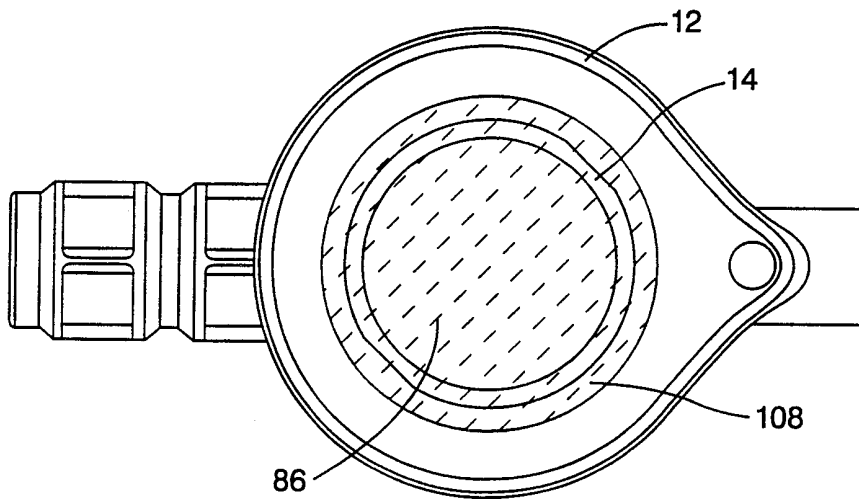

Fig. 14



10/11

Fig. 15

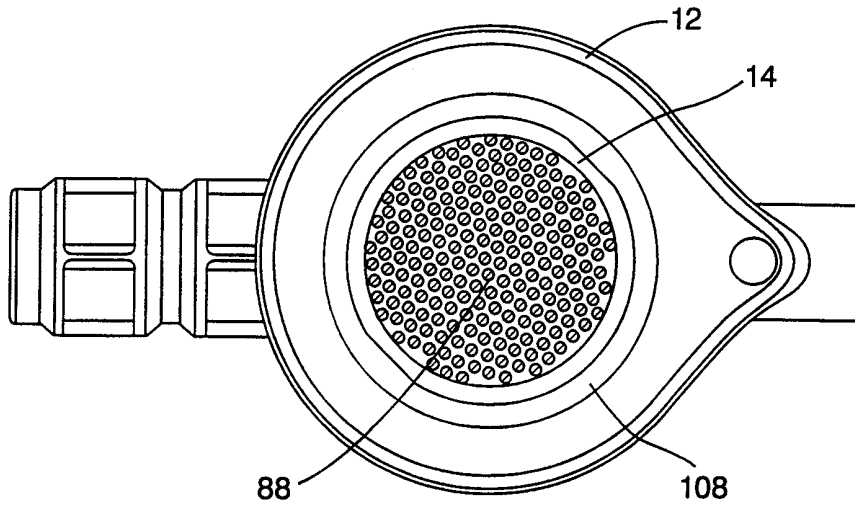

Fig. 16

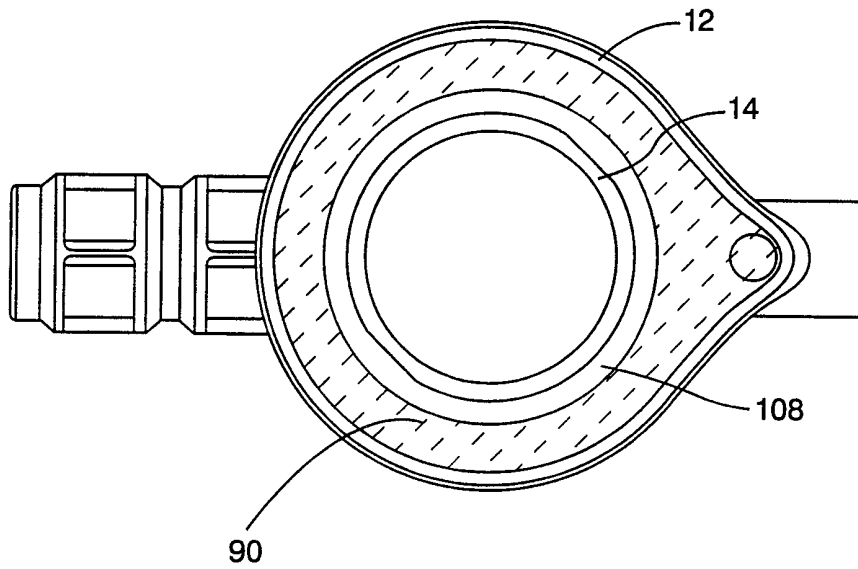
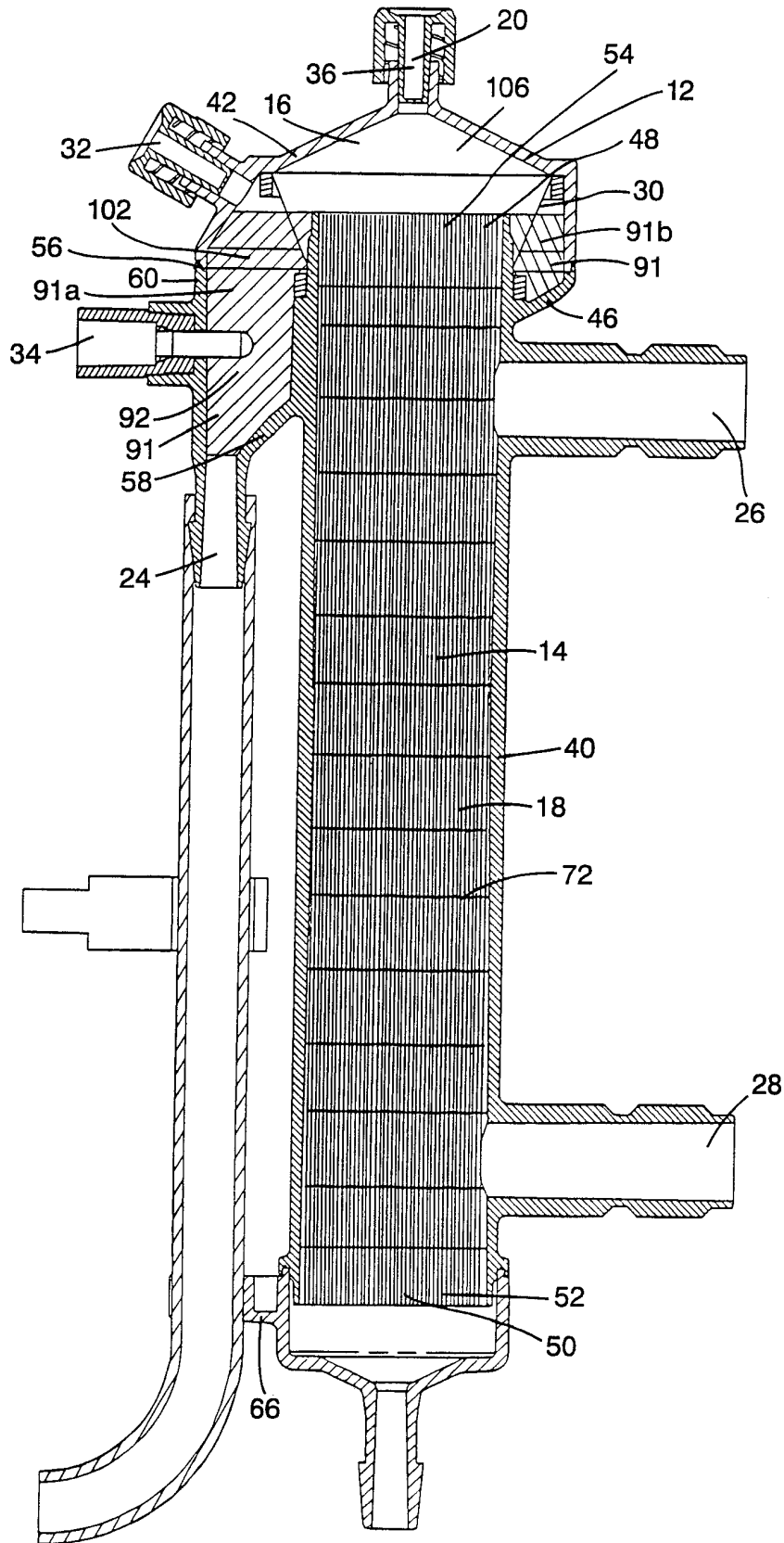

Fig. 17



INTERNATIONAL SEARCH REPORT

International application No.
PCT/US99/25620

A. CLASSIFICATION OF SUBJECT MATTER

IPC(6) : A61M 1/14
US CL : 422/44; 604/4

According to International Patent Classification (IPC) or to both national classification and IPC

B. FIELDS SEARCHED

Minimum documentation searched (classification system followed by classification symbols)

U.S. : 422/44; 604/4

Documentation searched other than minimum documentation to the extent that such documents are included in the fields searched

Electronic data base consulted during the international search (name of data base and, where practicable, search terms used)

EAST

C. DOCUMENTS CONSIDERED TO BE RELEVANT

Category*	Citation of document, with indication, where appropriate, of the relevant passages	Relevant to claim No.
E, T	US 5,997,816 A (MCINTOSH et al.) 07 December 1999, entire document.	1-31
A	US 5,124,127 A (JONES et al.) 23 June 1992, entire document.	1-31

 Further documents are listed in the continuation of Box C.
 See patent family annex.

* Special categories of cited documents:	"T" later document published after the international filing date or priority date and not in conflict with the application but cited to understand the principle or theory underlying the invention
"A" document defining the general state of the art which is not considered to be of particular relevance	"X" document of particular relevance; the claimed invention cannot be considered novel or cannot be considered to involve an inventive step when the document is taken alone
"E" earlier document published on or after the international filing date	"Y" document of particular relevance; the claimed invention cannot be considered to involve an inventive step when the document is combined with one or more other such documents, such combination being obvious to a person skilled in the art
"L" document which may throw doubts on priority claim(s) or which is cited to establish the publication date of another citation or other special reason (as specified)	"&" document member of the same patent family
"O" document referring to an oral disclosure, use, exhibition or other means	
"P" document published prior to the international filing date but later than the priority date claimed	

Date of the actual completion of the international search

20 FEBRUARY 2000

Date of mailing of the international search report

04 APR 2000

Name and mailing address of the ISA/US
Commissioner of Patents and Trademarks
Box PCT
Washington, D.C. 20231

Facsimile No. (703) 306-4520

Authorized officer

WILLIAM NOGGLE

Telephone No. (703) 308-4543