



US00D852502S

(12) **United States Design Patent**  
**Dolfi**

(10) **Patent No.:** **US D852,502 S**

(45) **Date of Patent:** **\*\* Jul. 2, 2019**

(54) **GUN CASE**

(71) Applicant: **Dennis Dolfi**, Broomfield, CO (US)

(72) Inventor: **Dennis Dolfi**, Broomfield, CO (US)

(73) Assignee: **The Allen Company, Inc.**, Broomfield, CO (US)

(\*\*) Term: **15 Years**

(21) Appl. No.: **29/601,855**

(22) Filed: **Apr. 26, 2017**

(51) **LOC (11) Cl.** ..... **03-01**

(52) **U.S. Cl.**  
USPC ..... **D3/262**

(58) **Field of Classification Search**  
USPC ..... D3/262, 254, 282, 201, 222, 232, 245,  
D3/269, 273, 276, 289, 301; D22/108,  
D22/199; D24/130; D21/570-575;  
42/96; 206/315.11, 317; 150/154;  
224/913  
CPC ..... F41C 33/02; F41C 33/03; F41C 33/04;  
F41C 33/05; F41C 33/06; F41C 33/07;  
F41C 33/08; Y10S 224/913; Y10S  
190/903; Y10S 493/935; A61M 5/3204;  
B65D 85/00; B65D 85/24; F41A 35/02;  
A61C 19/08; A60R 7/14; A60R 9/055;  
A60R 9/08

See application file for complete search history.

4,475,247 A \* 10/1984 Lee ..... F41C 33/06  
2/2.5  
D283,269 S \* 4/1986 Durbin ..... D3/262  
D284,622 S \* 7/1986 Durbin ..... D3/262  
D320,113 S 9/1991 VanSkiver  
D347,322 S 5/1994 Fiore  
D358,255 S 5/1995 Sharp  
D372,121 S \* 7/1996 Rowe ..... D3/262  
5,669,495 A 9/1997 West  
D404,914 S \* 2/1999 Revels ..... D3/262  
D413,020 S 8/1999 Kolpin  
D448,163 S 9/2001 Kolpin  
D448,558 S 10/2001 Kolpin  
D448,559 S 10/2001 Kolpin  
D448,560 S \* 10/2001 Kolpin ..... D3/262  
D448,561 S 10/2001 Kolpin  
D448,562 S 10/2001 Kolpin  
6,634,530 B1 10/2003 Black  
D486,637 S 2/2004 Sauey et al.  
6,722,496 B2 4/2004 Gantert  
D498,052 S \* 11/2004 Sauey ..... D14/203.7  
D520,235 S 5/2006 Blaschke  
7,063,737 B2 6/2006 Tilby et al.  
D528,790 S 9/2006 Sides

(Continued)

*Primary Examiner* — Cathron C Brooks  
*Assistant Examiner* — W. A. Teddy Falloway  
(74) *Attorney, Agent, or Firm* — Boyd D. Cox

(57) **CLAIM**  
The ornamental design for a gun case, as shown.

**DESCRIPTION**

FIG. 1 is a front elevation of the gun case of the present invention;  
FIG. 2 is a rear elevation of the gun case of FIG. 1;  
FIG. 3 is a left side elevation of the gun case of FIG. 1;  
FIG. 4 is a right side elevation of the gun case of FIG. 1;  
FIG. 5 is a top plan view of the gun case of FIG. 1; and,  
FIG. 6 is a bottom plan view of the gun case of FIG. 1.

**1 Claim, 6 Drawing Sheets**

(56) **References Cited**  
**U.S. PATENT DOCUMENTS**  
2,574,730 A \* 11/1951 Crew ..... F41C 33/06  
190/903  
3,191,652 A 6/1965 Benson  
3,865,166 A 2/1975 Pedro  
D262,416 S 12/1981 Bianchi  
D266,632 S \* 10/1982 Schroeder ..... D3/260

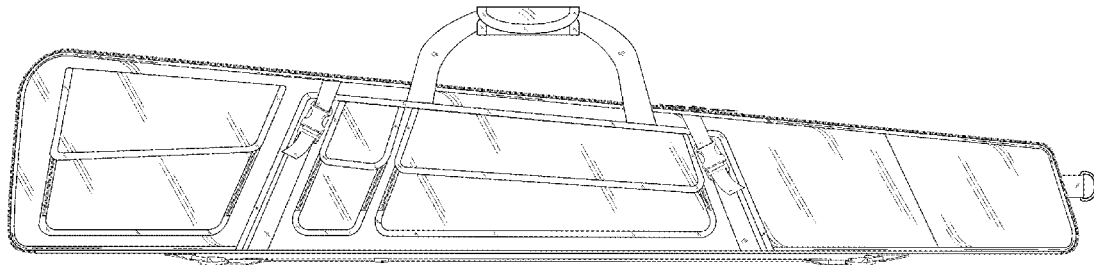

(56)

**References Cited**

U.S. PATENT DOCUMENTS

D528,791	S	9/2006	Sides	
D532,971	S	12/2006	Sides	
7,360,648	B1 *	4/2008	Blaschke .....	F41C 33/06 206/317
7,434,683	B1	10/2008	Harper	
7,546,920	B1	6/2009	Horn et al.	
7,905,350	B2	3/2011	Wood et al.	
D641,166	S	7/2011	Zivanovic	
D715,047	S	10/2014	Morris	
D731,789	S	6/2015	Quinnan	
D744,234	S	12/2015	Quinnan	
D759,375	S	6/2016	Dolfi	
D782,192	S	3/2017	Scranton	
2004/0079660	A1 *	4/2004	Sauey .....	F41C 33/06 206/317

\* cited by examiner

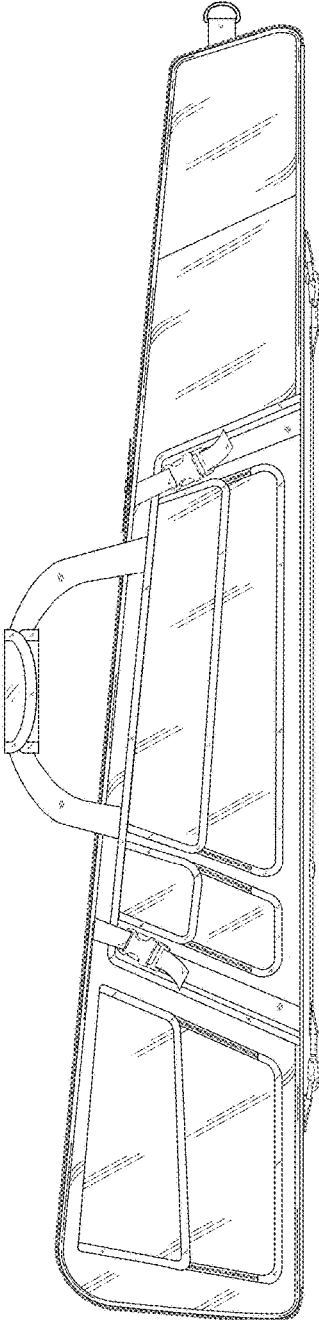

FIG.1

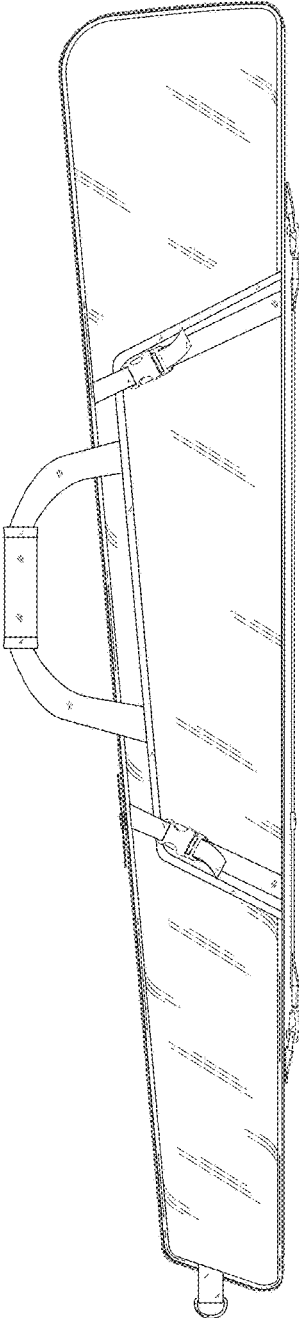

FIG.2

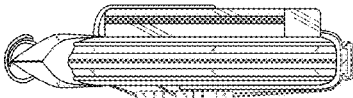

FIG.3

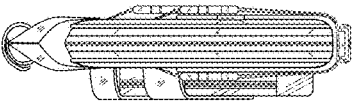

FIG.4

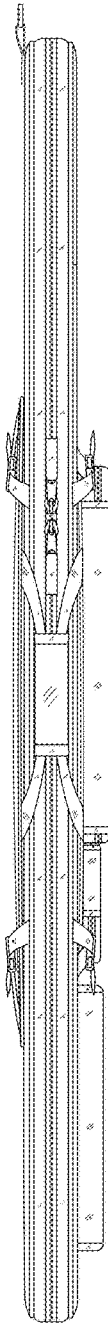

FIG.5

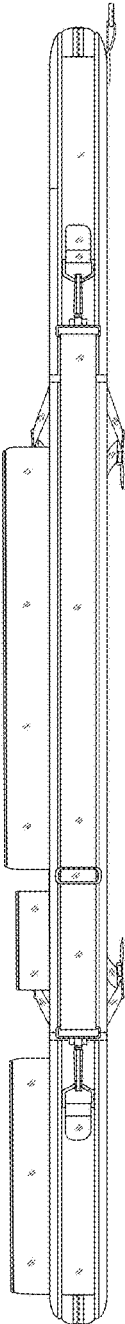

FIG.6