

(12) PATENT
(19) AUSTRALIAN PATENT OFFICE

(11) Application No. AU 199916777 B2
(10) Patent No. 745342

(54) Title
A handle for a vacuum cleaner

(51)⁶ International Patent Classification(s)
A47L 009/32

(21) Application No: 199916777 (22) Application Date: 1998 .12 .17

(87) WIPO No: W099/30605

(30) Priority Data

(31) Number	(32) Date	(33) Country
9726669	1997 .12 .17	GB

(43) Publication Date : 1999 .07 .05
(43) Publication Journal Date : 1999 .09 .02
(44) Accepted Journal Date : 2002 .03 .21

(71) Applicant(s)
Notetry Limited

(72) Inventor(s)
James Dyson

(74) Agent/Attorney
BALDWIN SHELSTON WATERS,Level 21,60 Margaret Street,SYDNEY NSW 2000

(56) Related Art
US 4443910
EP 887040

PCT

WORLD INTELLECTUAL PROPERTY ORGANIZATION
International Bureau



INTERNATIONAL APPLICATION PUBLISHED UNDER THE PATENT COOPERATION TREATY (PCT)

<p>(51) International Patent Classification ⁶ : A47L 9/32</p>	<p>A1</p>	<p>(11) International Publication Number: WO 99/30605 (43) International Publication Date: 24 June 1999 (24.06.99)</p>
<p>(21) International Application Number: PCT/GB98/03815 (22) International Filing Date: 17 December 1998 (17.12.98) (30) Priority Data: 9726669.6 17 December 1997 (17.12.97) GB (71) Applicant (for all designated States except US): NOTETRY LIMITED [GB/GB]; Kingsmead Mill, Little Somerford, Wiltshire SN15 5JN (GB). (72) Inventor; and (75) Inventor/Applicant (for US only): DYSON, James [GB/GB]; Kingsmead Mill, Little Somerford, Wiltshire SN15 5JN (GB). (74) Agent: DEVONS, David, Jon; Marks & Clerk, 57-60 Lincoln's Inn Fields, London WC2A 3LS (GB).</p>	<p>(81) Designated States: AL, AM, AT, AU, AZ, BA, BB, BG, BR, BY, CA, CH, CN, CU, CZ, DE, DK, EE, ES, FI, GB, GD, GE, GH, GM, HR, HU, ID, IL, IN, IS, JP, KE, KG, KP, KR, KZ, LC, LK, LR, LS, LT, LU, LV, MD, MG, MK, MN, MW, MX, NO, NZ, PL, PT, RO, RU, SD, SE, SG, SI, SK, SL, TJ, TM, TR, TT, UA, UG, US, UZ, VN, YU, ZW, ARIPO patent (GH, GM, KE, LS, MW, SD, SZ, UG, ZW), Eurasian patent (AM, AZ, BY, KG, KZ, MD, RU, TJ, TM), European patent (AT, BE, CH, CY, DE, DK, ES, FI, FR, GB, GR, IE, IT, LU, MC, NL, PT, SE), OAPI patent (BF, BJ, CF, CG, CI, CM, GA, GN, GW, ML, MR, NE, SN, TD, TG).</p> <p>Published <i>With international search report. Before the expiration of the time limit for amending the claims and to be republished in the event of the receipt of amendments.</i></p> <div data-bbox="949 817 1225 981" style="border: 1px solid black; padding: 5px; text-align: center;"><p>IP AUSTRALIA - 5 JUL 1999 RECEIVED</p></div>	
<p>(54) Title: A HANDLE FOR A VACUUM CLEANER</p>		
<p>(57) Abstract</p>		

A handle for a vacuum cleaner (100) comprises a generally rigid pipe portion (10) connected to a generally flexible hose portion, the hose portion being fixedly connected to the main body (3) of the vacuum cleaner (100), the pipe portion (10) being selectively connectable to the main body (3) of the vacuum cleaner (100) in the manner of a handle or releasable from the main body (3) in the manner of a wand (9). According to the invention, the pipe portion (10) is formed by a straight, hollow tube having no internal bends. The handle may have an upwardly extending handle portion and a gripping portion (12), wherein the gripping portion (12) extends forwardly and downwardly from the handle portion so that, when the vacuum cleaner (100) is in use in an upright mode, the gripping portion (12) extends generally transverse to the forearm of the user. A cap (17) may also be provided at the distal end of the rigid pipe portion (10), the cap (17) being movable between a first position in which the end of the pipe portion (10) is closed by the cap (17) and a second position in which the end of the pipe portion (10) is not closed by the cap (17).

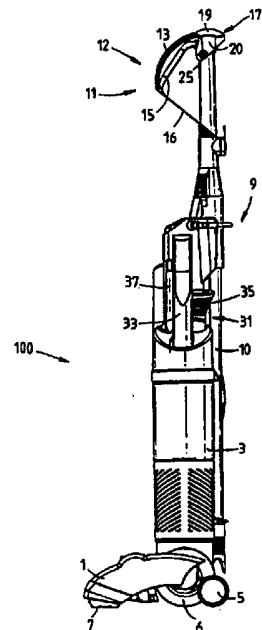

A HANDLE FOR A VACUUM CLEANER

The present invention relates to a handle for a vacuum cleaner.

Any discussion of the prior art throughout the specification should in no way be considered as an admission that such prior art is widely known or forms part of common
5 general knowledge in the field.

An upright vacuum cleaner generally comprises a cleaner head rotatably mounted to the lower end of the main body of the vacuum cleaner which houses the dust separation apparatus, which can take the form of a bag, a cyclonic separator, or any suitable separation apparatus. The cleaner head has a downwardly directed dirty air inlet
10 through which dirty air is sucked into the dust separation apparatus. This type of vacuum cleaner is often convertible between an upright mode and a cylinder mode.

In the upright mode, the vacuum cleaner is moved over the surface to be cleaned so that the dirty air enters the dust separation apparatus via the dirty air inlet in the cleaner head whilst the main body is inclined rearwardly. The vacuum cleaner
15 comprises an upwardly extending handle which the user can use to move the vacuum cleaner over the surface to be cleaned.

In the cylinder mode, the main body is put into an upright position and a hose or wand, which is fixedly connected to the main body of the vacuum cleaner, is used to introduce dirty air to the dust separation apparatus for above-floor cleaning.

One known type of upright vacuum cleaner, for example disclosed by EP
20 134654, comprises a wand having a generally rigid pipe portion and a generally flexible hose portion. The hose portion is fixedly connected to the main body of the vacuum and the rigid pipe portion is selectively connectable to the main body of the vacuum cleaner whilst remaining in telescoping connection with the hose portion. In the cylinder mode,
25 the rigid pipe portion is connected to the main body of the vacuum cleaner via the flexible hose. This allows the user to grip the rigid pipe portion and to manoeuvre it freely with respect to the main body. Tools such as a nozzle or brush are attached to the distal end of the rigid pipe portion which then forms the dirty air inlet of the vacuum cleaner for above-floor cleaning.

30



In the upright mode, the rigid pipe portion is slid telescopically inside the hose portion and clipped to the back of the main body of the vacuum cleaner so that the rigid pipe portion extends upwardly from the main body to form a handle. The user can then grasp the handle to move the cleaner head over the surface to be cleaned.

5 The distal end of the rigid pipe portion is bent rearwardly towards the user to provide a more comfortable gripping portion when the vacuum cleaner is used in the upright mode. However, such an inclined gripping portion can allow blockages to occur. Also, the rearward inclination of the distal end of the rigid pipe portion makes it difficult to see whether the pipe portion is blocked and to clear any blockage when the cleaner is
10 being used in the cylinder mode.

It is an object of the present invention to overcome or ameliorate at least one of the disadvantages of the prior art, or to provide a useful alternative.

An object of at least a preferred embodiment of the present invention is to provide a wand for a vacuum cleaner in which the risk of blockage is reduced and visual
15 access to allow checking for blockages is improved.

The present invention provides a handle for a vacuum cleaner comprising a rigid pipe portion connected to a flexible hose portion, the hose portion being fixedly connected to a main body of the vacuum cleaner, the pipe portion being selectively connectable to the main body of the vacuum cleaner in the manner of a handle or
20 releasable from the main body in the manner of a wand and, having a free distal end and a proximal end, the distal end forming a dirty air inlet of the vacuum cleaner, wherein the pipe portion is formed by a straight, hollow tube having no internal bends between the free distal end and the proximal end.

Unless the context clearly requires otherwise, throughout the description and the
25 claims, the words 'comprise', 'comprising', and the like are to be construed in an inclusive as opposed to an exclusive or exhaustive sense; that is to say, in the sense of "including, but not limited to".

Since the rigid pipe portion is formed by a straight, hollow tube, it is possible to see down the pipe portion to check whether it is blocked. This can easily be done by
30 detaching the rigid pipe portion from the flexible hose portion and holding the pipe portion up to the light. Since there are no internal bends in the pipe portion, light will



pass through the pipe portion if it is not blocked. Furthermore, since the dirty air flows along a straight path, there is less risk of blockage.

Preferably, the handle has an upwardly extending handle portion and a gripping portion extending forwardly and downwardly from the handle portion so that, when the vacuum cleaner is in use in an upright mode, the gripping portion extends generally transverse to the forearm of the user. The handle can then be gripped by the user so that the hand, wrist and lower arm are in alignment and are not twisted as in the conventional arrangement. The vacuum cleaner can then be moved backwards and forwards over the surface to be cleaned in the normal way but this is achieved by a "sawing" action which produces less strain on the wrist and is more comfortable for the user.

The gripping portion, preferably, extends forwardly and downwardly at an acute angle to the longitudinal axis of the handle portion so that, in use, the gripping portion is approximately horizontal which causes less twist on the wrist and hence less strain.

The rigid pipe portion of the above mentioned vacuum cleaner comprises a hollow tube into which objects can drop and possibly cause a blockage. Furthermore, improper use of the wand can cause injury and any domestic appliance is at risk of improper use, for example, by children. The exposed open end of the rigid pipe portion of the wand can be particularly dangerous.

Therefore, the present invention further seeks to overcome these disadvantages by providing a handle for a vacuum cleaner comprising a rigid pipe portion connected to a flexible hose portion, the hose portion being fixedly connected to a main body of the vacuum cleaner, the pipe portion being selectively connectable to the main body of the vacuum cleaner in the manner of a handle or releasable from the main body in the manner of a wand, wherein a cap is provided at the distal end of the pipe portion, the cap being movable between a first position in which the end of the pipe portion is closed by the cap and a second position in which the end of the pipe portion is not closed by the cap.

The closure of the distal end of the pipe portion by the cap helps to prevent objects dropping into the pipe and to minimise the risk of injuries through improper use.

Preferably, the cap is pivotally attached to the pipe portion.



The wand may comprise means for hanging the vacuum cleaner from a wall so that the vacuum cleaner can be easily stored away. The hanging means may be in the form of a hook and may also be integral with the cap.

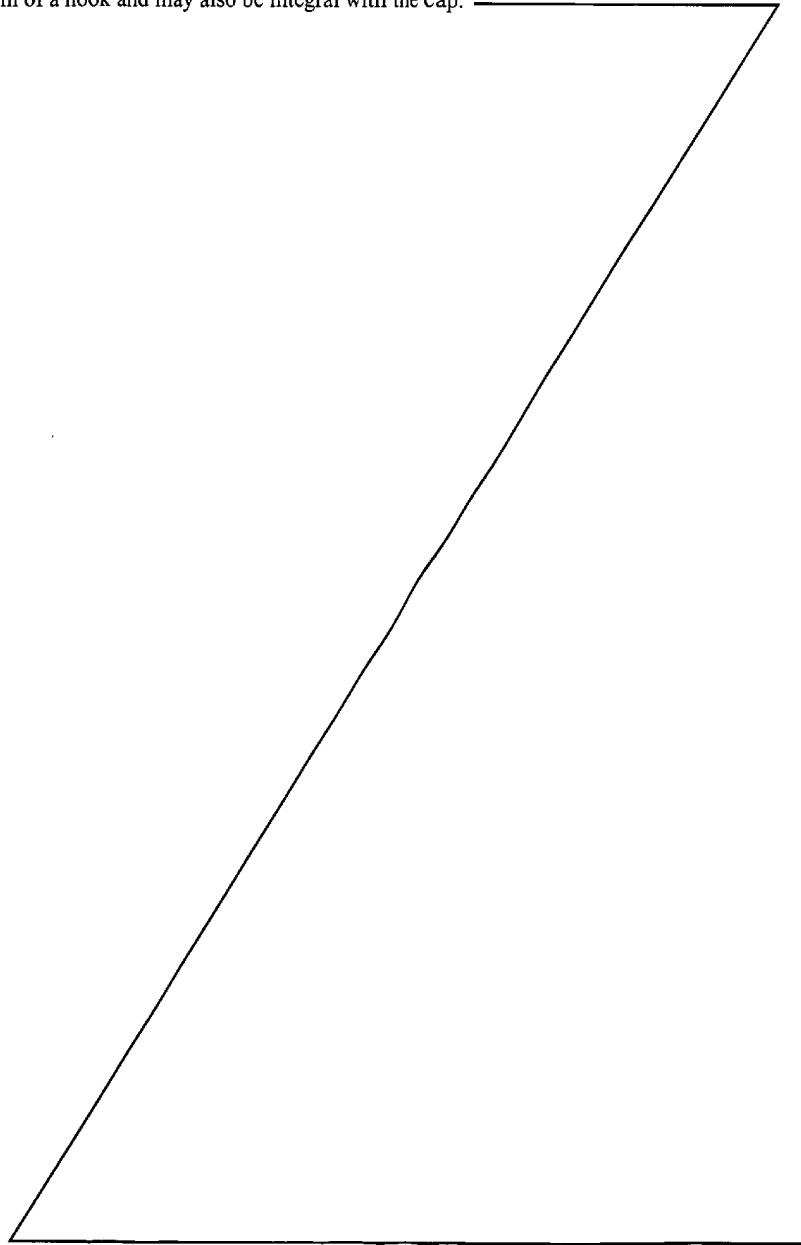

NOT ORDER



An embodiment of the invention will now be described and fully explained with reference to the accompanying drawings, wherein

Figure 1 illustrates a vacuum cleaner having a handle according to an embodiment of the present invention;

Figure 2 shows a perspective view of the handle, of Figure 1;

Figure 3 shows a side view of the handle, of Figure 1 with the cap shown in the closed position; and

Figure 4 shows a side view of the handle, of Figure 1 with the cap shown in its open position.

The present invention will now be described in more detail with reference to Figures 1 to 4.

The vacuum cleaner 100 comprises a cleaner head 1 rotatably mounted to the lower end of the main body 3 of the vacuum cleaner 100. The main body 3 houses dust separating apparatus in the form of a dust bag, cyclonic separator, etc. A pair of wheels 5 are also mounted at the lower end of the main body 3 via a motor casing 6 from which the cleaner head 1 extends in a forward direction.

The cleaner head 1 has a dirty air inlet 7 located at its forward end and facing downwardly so that, in use in an upright mode, the dirty air inlet 7 contacts a surface to be cleaned and dirty air enters the cleaner head 1 via the dirty air inlet 7 before being conducted to the dust separating apparatus (not shown). A wand 9 is releasably attached to the rear side of the main body 3 of the vacuum cleaner 100. The wand 9 can be detached from the main body 3 of the vacuum cleaner 100 and extended for use in a cylinder mode in which the distal end of the wand 9 becomes the active dirty air inlet. Means are provided for shutting off the dirty air inlet in the cleaner head 1 when it is used in the cylinder mode.

The wand 9 comprises a rigid pipe portion 10 and a flexible hose portion. The proximal end 10' of the rigid pipe portion 10 is slidably and releasably connected to one end of a flexible hose portion to allow telescopic sliding of the pipe portion 10 within the hose portion. The other end of the flexible hose portion is fixedly connected to the lower end of the main body 3 of the vacuum cleaner. The pipe portion 10 and hose portion together provide an air flow path into the dust separation apparatus when the



AMENDED

vacuum cleaner is used in a cylinder mode. The pipe portion 10 of the wand 9 consists of a straight, hollow tube having no internal bends. This reduces the risk of blockage and also allows the user to look down the pipe 10 in case of a blockage and to remove the blockage by introducing an elongate tool into the pipe portion from one end. The absence of any internal bends allows this.

The pipe portion 10 extends upwardly from the main body of the vacuum cleaner to form a handle 11 when the vacuum cleaner 100 is to be used in its upright mode. The handle 11 comprises a gripping portion 12 which extends forwardly and downwardly from the distal end of the pipe portion 10 at an acute angle to longitudinal axis of the pipe portion 10. The gripping portion 12 comprises an outer portion 13 having a curved outer surface and an inner portion 15. The gripping portion 12 is shaped so as to be comfortable for a user gripping the gripping portion 12. A lower portion 16 of the handle 11 extends from the forward end of the gripping portion 12 downwardly and rearwardly to attach the gripping portion 12 of the handle 11 to the pipe portion 10 at a point approximately midway between the distal end of the pipe portion 10 and the top of the main body 3 of the vacuum cleaner 100. The lower portion 16 braces the gripping portion and provides strength and stability thereto.

In the upright cleaning mode, the wand 9 is clipped to the main body 3 of the vacuum cleaner 100 so that the rigid pipe portion 10 extends upwardly from the main body 3 as shown in the Figures. The gripping portion 12 of the handle 11 is grasped by the user and the main body 3 of the vacuum cleaner 100 is tilted rearwardly towards the user and away from the cleaner head 1. In this position, the pipe portion 10 lies beneath the gripping portion 12 and the gripping portion 12 is approximately horizontal. The user moves the vacuum cleaner in a forward and backward direction over the surface to be cleaned. This corresponds to a "sawing" action and the hand, wrist and lower arm of the user are in alignment, which causes less strain on the wrist than many known arrangements. The main body 3 of the vacuum cleaner 100 can be laid flat on the ground. In this horizontal position, the gripping portion 12 extends upwardly from the pipe portion 10 and, therefore, the vacuum cleaner can easily be lifted by grasping the gripping portion 12. This is advantageous for elderly and disabled users.



UNRECORDED SHEET

A cap 17 is pivotably attached to the distal end of the pipe portion 10 at a pivot point 25 on either side of the pipe portion 10. The pivot points 25 are located beneath the point at which the gripping portion 12 is attached to the pipe portion 10. The cap 17 comprises an outer curved surface 19 remote from the pivot points 25 and two side walls 20. The side walls 20 each extend downwardly from the curved surface 19 to the respective pivot point 25 on either side of the rigid pipe portion 10. The outer curved surface 19 is longer than the end of the pipe portion 10 so that, when in the closed position illustrated in Figure 3, the curved surface 19 extends rearwardly over the top of the distal end 27 of the pipe portion 10 and beyond the pipe portion 10 to form a recess 29 which forms a hook for hanging the vacuum cleaner on a wall. Biasing means (not shown) such as a spring or resilient strip, urge the cap 17 into the closed position. The cap 17 in its closed position, as shown in Figure 3, covers the remote end of the wand 9 to prevent objects dropping down into the wand 9 and also to reduce the risk of injury through improper use. The hook 29 enables the vacuum cleaner 100 to be hung from a wall.

In the cylinder mode, the wand 9 is released from the main body 3 of the vacuum cleaner 100. The cap 17 is tilted rearwardly away from the open, distal end 27 of the wand 9 to expose the dirty air inlet. Accessory tools 31 can then be attached to the wand 9. The accessory tools 31 may include a nozzle 33, a circular brush 35 or a crevice tool 37. Attaching a tool, as required, to the open end 27 of the wand 9 forms the dirty air inlet of the vacuum cleaner 100 and retains the cap 17 in the open position.

The accessory tools 31 can be stored on top of the dust separating apparatus of the vacuum cleaner 100 so that they are easily accessible. Alternatively, they can be stored on top of the cleaner head 1. The tools 31 may be stored on corresponding sockets or pegs or held by clips.

In the light of this disclosure, modifications of the described embodiments as well as other embodiments, all within the scope of the appended claims will now become apparent to a person skilled in the art.



THE CLAIMS DEFINING THE INVENTION ARE AS FOLLOWS:-

1. A handle for a vacuum cleaner comprising a rigid pipe portion connected to a flexible hose portion, the hose portion being fixedly connected to a main body of the vacuum cleaner, the pipe portion being selectively connectable to the main body of the vacuum cleaner in the manner of a handle or releasable from the main body in the manner of a wand and, having a free distal end and a proximal end, the distal end forming a dirty air inlet of the vacuum cleaner, wherein the pipe portion is formed by a straight, hollow tube having no internal bends between the free distal end and the proximal end.
2. A handle according to claim 1, wherein the pipe portion has an upwardly extending handle portion and a gripping portion extending forwardly and downwardly from the handle portion so that, when the vacuum cleaner is in use in an upright mode, the gripping portion extends generally transverse to the forearm of the user.
3. A handle according to claim 2, wherein the gripping portion extends forwardly and downwardly at an acute angle to the longitudinal axis of the handle portion.
4. A handle according to any one of the preceding claims, further comprising a cap located at the distal end of the pipe portion, the cap being movable between a first position in which the end of the pipe portion is closed by the cap and a second position in which the end of the pipe portion is not closed by the cap.
5. A handle for a vacuum cleaner comprising a rigid pipe portion connected to a flexible hose portion, the hose portion being fixedly connected to a main body of the vacuum cleaner, the pipe portion being selectively connectable to the main body of the vacuum cleaner in the manner of a handle or releasable from the main body in the manner of a wand, wherein a cap is provided at the distal end of the pipe portion, the cap being movable between a first position in which the end of the pipe portion is closed by the cap and a second position in which the end of the pipe portion is not closed by the cap.
6. A handle according to claim 4 or 5, wherein the cap is pivotably attached to the pipe portion.
- A handle according to any one of claims 4 to 6, wherein the cap is biased into one of the first and second positions.



8. A handle according to claim 7, wherein the cap is biased into the first position.
 9. A handle according to any one of claims 4 to 8, wherein the cap incorporates hook means for allowing the vacuum cleaner to be hung up.
 10. A handle for a vacuum cleaner substantially as hereinbefore described with
5 reference to any one of the accompanying drawings.
 11. A vacuum cleaner incorporating a handle according to any one of the preceding claims.
 12. A vacuum cleaner substantially as hereinbefore described with reference to any one of the Figures.
- 10 Dated this 19th Day of September, 2000
NOTETRY LIMITED

Attorney: KENNETH W. BOLTON
Registered Patent and Trade Mark Attorney of Australia
of BALDWIN SHELDON WATERS

15

SECRET

SECRET



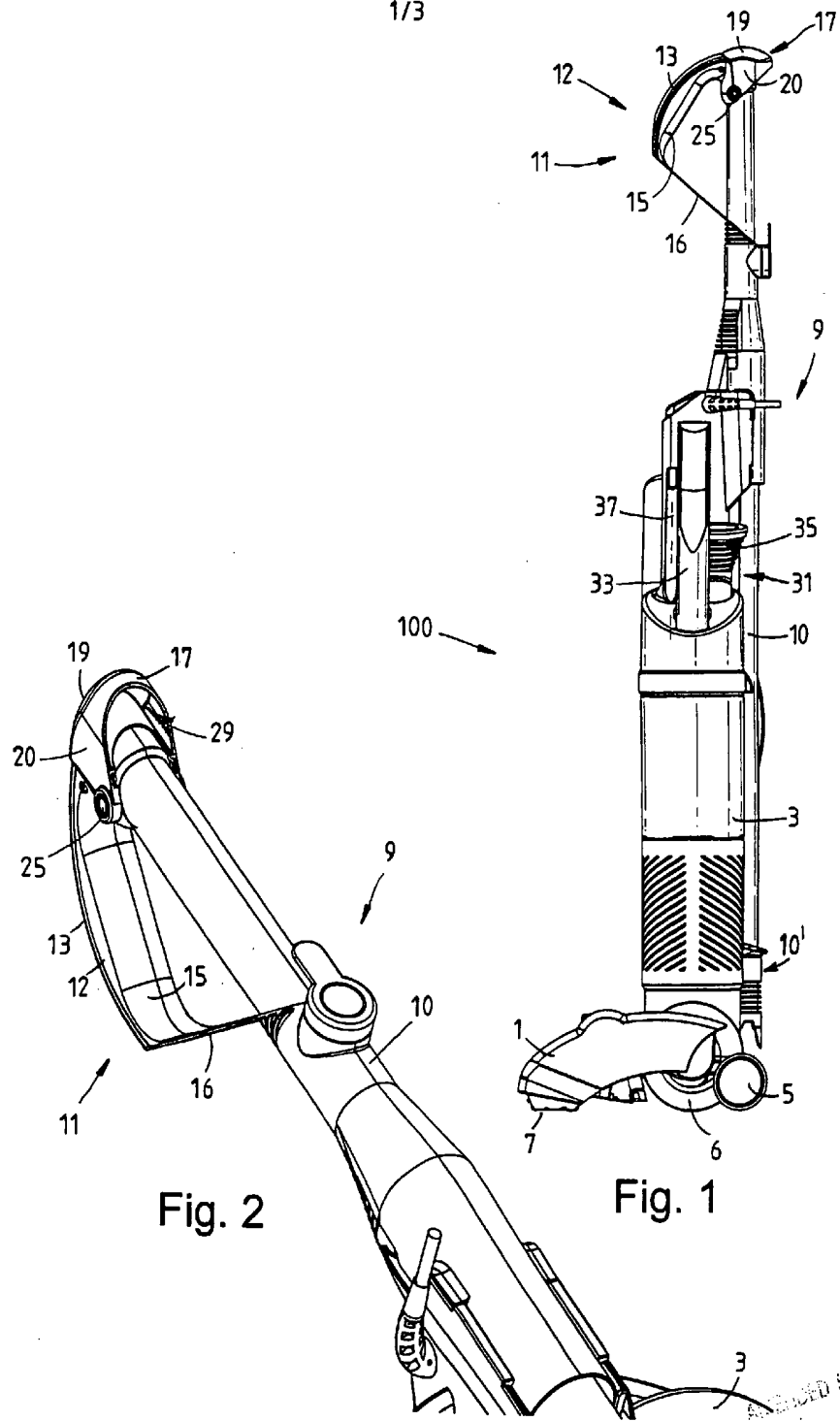

Fig. 2

Fig. 1

ADDED SHEET

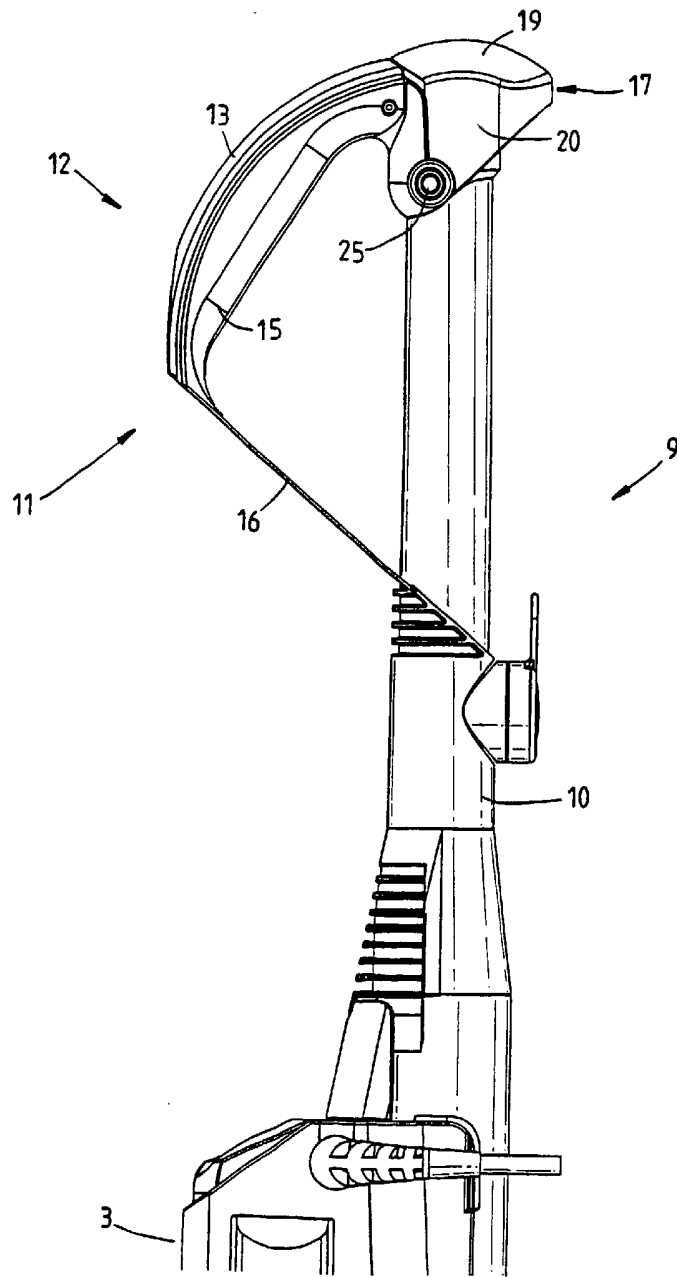

Fig. 3
SUBSTITUTE SHEET (rule 26)

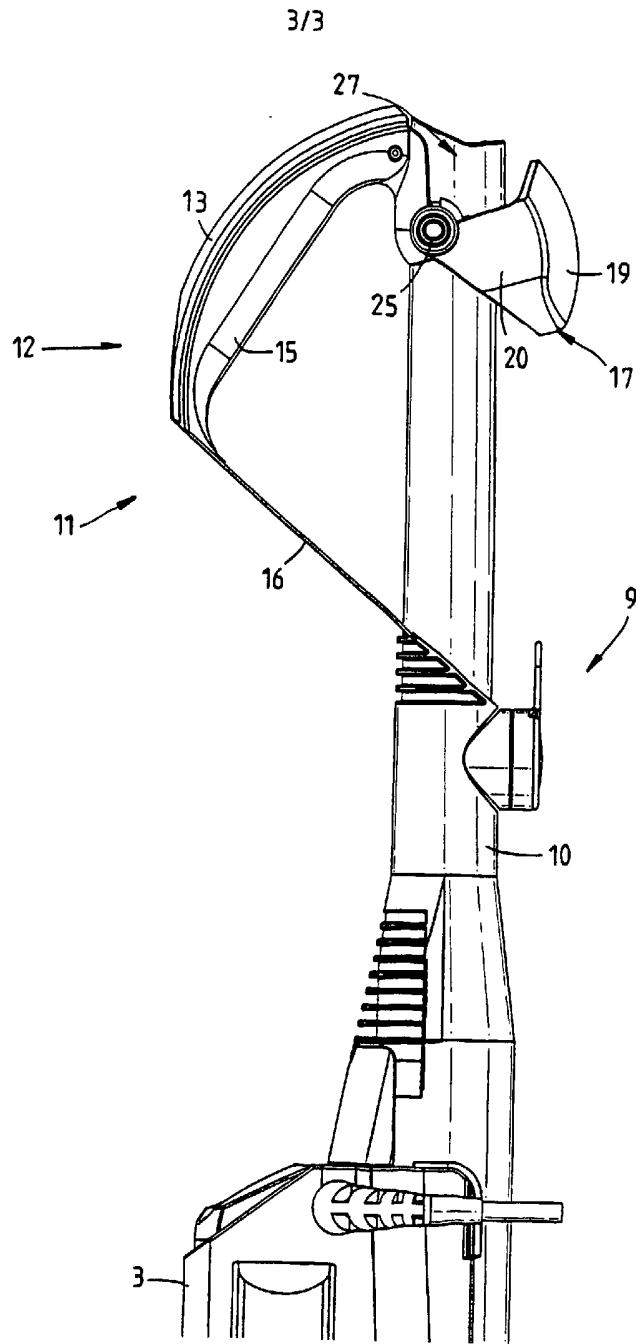

Fig. 4

SUBSTITUTE SHEET (rule 26)