



(12) **DEMANDE DE BREVET CANADIEN
CANADIAN PATENT APPLICATION**

(13) **A1**

(86) Date de dépôt PCT/PCT Filing Date: 2017/12/21
(87) Date publication PCT/PCT Publication Date: 2018/06/28
(85) Entrée phase nationale/National Entry: 2019/06/20
(86) N° demande PCT/PCT Application No.: CA 2017/051580
(87) N° publication PCT/PCT Publication No.: 2018/112653
(30) Priorité/Priority: 2016/12/21 (US62/437,138)

(51) Cl.Int./Int.Cl. *B01D 53/54* (2006.01),
B01D 53/14 (2006.01), *B01D 53/50* (2006.01),
B01D 53/64 (2006.01)
(71) Demandeur/Applicant:
ISCA MANAGEMENT LTD., CA
(72) Inventeur/Inventor:
MUELLER, BARBARA, CA
(74) Agent: GOWLING WLG (CANADA) LLP

(54) Titre : ELIMINATION DE GAZ A EFFET DE SERRE ET DE METAUX LOURDS A PARTIR D'UN FLUX D'EMISSION
(54) Title: REMOVAL OF GREENHOUSE GASES AND HEAVY METALS FROM AN EMISSION STREAM

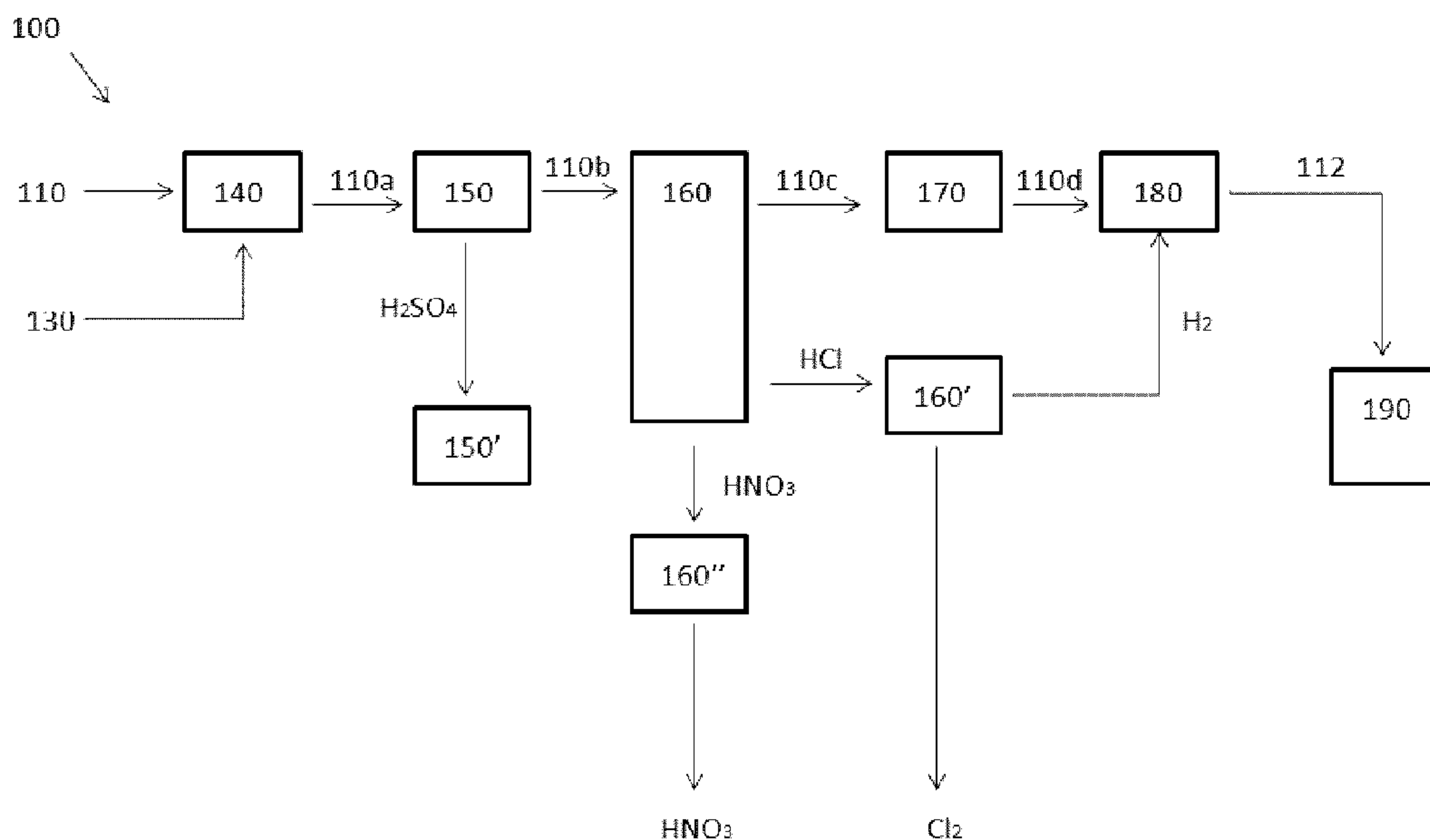

FIGURE 1

(57) **Abrégé/Abstract:**

The present disclosure relates to a flue gas treatment system (e.g. a multi-pollutant flue gas treatment system) for removal of greenhouse gases such as SO₂, NO, NO₂, H₂S, HCl, water and CO₂ as well as heavy metals (e.g. mercury, arsenic, bismuth, cadmium, lead and/or selenium) from the flue gases of fossil-fueled utility and industrial plants by reacting the raw flue gas, firstly, with chlorine in a gas-phase oxidation reaction and recovering the resulting products as marketable products, and then, secondly, treating the cleaned gas, which includes CO₂, with a Sabatier reaction to produce a hydrocarbon fuel (e.g. methane). The system also includes an electrolytic unit for electrolyzing HCl to produce hydrogen gas for the Sabatier reaction as well as chlorine gas, which may then be recycled into the reactor.

(12) INTERNATIONAL APPLICATION PUBLISHED UNDER THE PATENT COOPERATION TREATY (PCT)

(19) World Intellectual Property
Organization
International Bureau(43) International Publication Date
28 June 2018 (28.06.2018)(10) International Publication Number
WO 2018/112653 A1

(51) International Patent Classification:

B01D 53/54 (2006.01) *B01D 53/50* (2006.01)
B01D 53/14 (2006.01) *B01D 53/64* (2006.01)

(21) International Application Number:

PCT/CA2017/051580

(22) International Filing Date:

21 December 2017 (21.12.2017)

(25) Filing Language:

English

(26) Publication Language:

English

(30) Priority Data:

62/437,138 21 December 2016 (21.12.2016) US

(71) Applicant: ISCA MANAGEMENT LTD. [CA/CA];
#204-5525 West Boulevard, Vancouver, British Columbia
V6M 3W6 (CA).

(72) Inventor: MUELLER, Barbara; #204-5525 West Boule-
vard, Vancouver, British Columbia V6M 3W6 (CA).

(74) Agent: WILKE, Mark et al.; 550 Burrard Street, Suite
2300, Bentall 5, Vancouver, British Columbia V6C 2B5
(CA).

(81) Designated States (unless otherwise indicated, for every
kind of national protection available): AE, AG, AL, AM,
AO, AT, AU, AZ, BA, BB, BG, BH, BN, BR, BW, BY, BZ,
CA, CH, CL, CN, CO, CR, CU, CZ, DE, DJ, DK, DM, DO,
DZ, EC, EE, EG, ES, FI, GB, GD, GE, GH, GM, GT, HN,
HR, HU, ID, IL, IN, IR, IS, JO, JP, KE, KG, KH, KN, KP,
KR, KW, KZ, LA, LC, LK, LR, LS, LU, LY, MA, MD, ME,
MG, MK, MN, MW, MX, MY, MZ, NA, NG, NI, NO, NZ,
OM, PA, PE, PG, PH, PL, PT, QA, RO, RS, RU, RW, SA,
SC, SD, SE, SG, SK, SL, SM, ST, SV, SY, TH, TJ, TM, TN,
TR, TT, TZ, UA, UG, US, UZ, VC, VN, ZA, ZM, ZW.

(84) Designated States (unless otherwise indicated, for every
kind of regional protection available): ARIPO (BW, GH,
GM, KE, LR, LS, MW, MZ, NA, RW, SD, SL, ST, SZ, TZ,
UG, ZM, ZW), Eurasian (AM, AZ, BY, KG, KZ, RU, TJ,
TM), European (AL, AT, BE, BG, CH, CY, CZ, DE, DK,

(54) Title: REMOVAL OF GREENHOUSE GASES AND HEAVY METALS FROM AN EMISSION STREAM

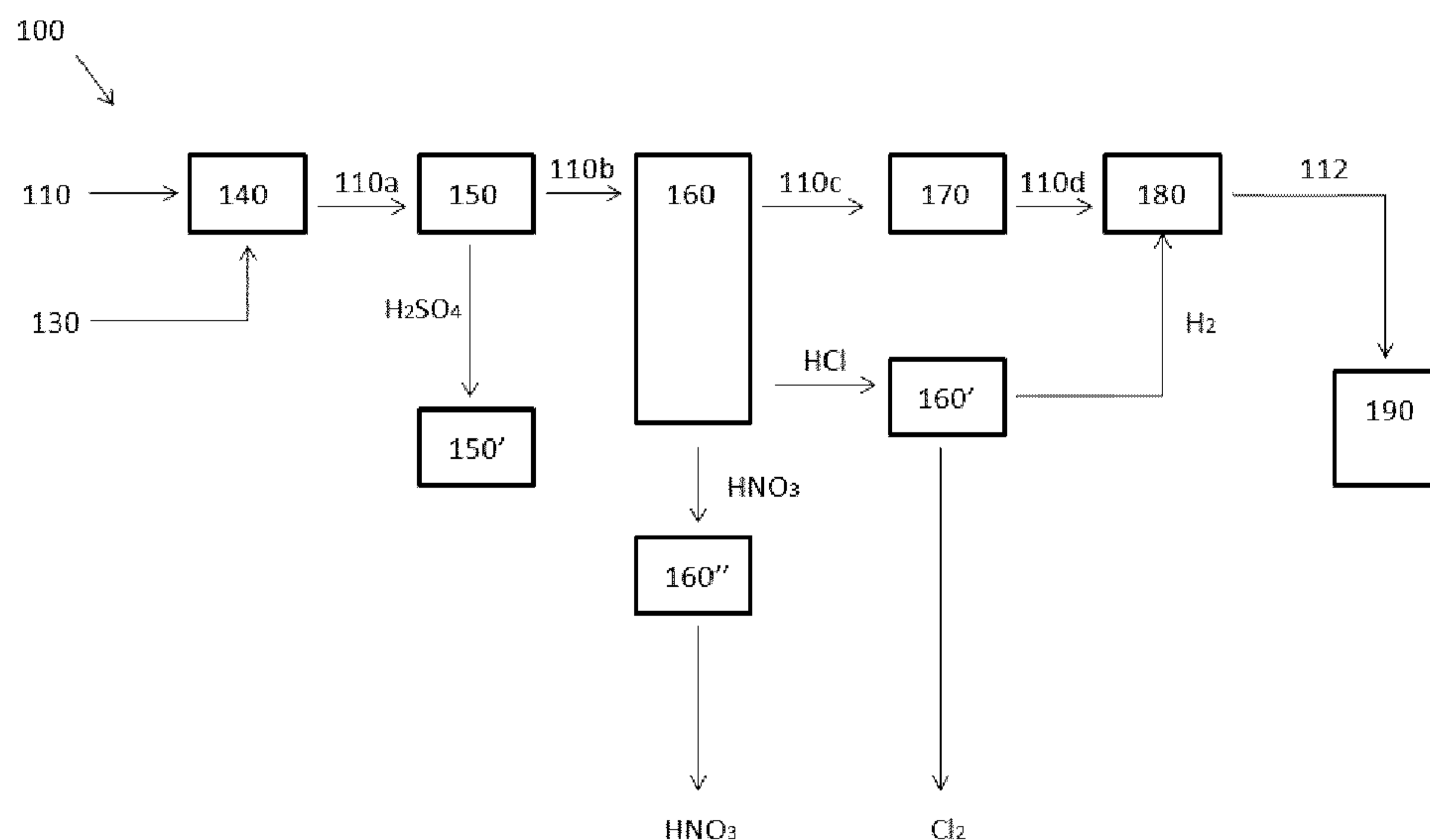

FIGURE 1

(57) Abstract: The present disclosure relates to a flue gas treatment system (e.g. a multi-pollutant flue gas treatment system) for removal of greenhouse gases such as SO₂, NO, NO₂, H₂S, HCl, water and CO₂ as well as heavy metals (e.g. mercury, arsenic, bismuth, cadmium, lead and/or selenium) from the flue gases of fossil-fueled utility and industrial plants by reacting the raw flue gas, firstly, with chlorine in a gas-phase oxidation reaction and recovering the resulting products as marketable products, and then, secondly, treating the cleaned gas, which includes CO₂, with a Sabatier reaction to produce a hydrocarbon fuel (e.g. methane). The system also includes an electrolytic unit for electrolyzing HCl to produce hydrogen gas for the Sabatier reaction as well as chlorine gas, which may then be recycled into the reactor.

[Continued on next page]

WO 2018/112653 A1

EE, ES, FI, FR, GB, GR, HR, HU, IE, IS, IT, LT, LU, LV,
MC, MK, MT, NL, NO, PL, PT, RO, RS, SE, SI, SK, SM,
TR), OAPI (BF, BJ, CF, CG, CI, CM, GA, GN, GQ, GW,
KM, ML, MR, NE, SN, TD, TG).

Published:

- *with international search report (Art. 21(3))*
- *in black and white; the international application as filed contained color or greyscale and is available for download from PATENTSCOPE*

REMOVAL OF GREENHOUSE GASES AND HEAVY METALS FROM AN EMISSION STREAM

TECHNICAL FIELD:

[0001] The present disclosure relates to a system and a method for removing greenhouse gases and other pollutants from emission stream.

BACKGROUND:

[0002] Flue gas generally refers to the exhaust gas produced by energy generating apparatuses or systems such as, but not limited to, power plants, coal-fired facilities, gas burning facilities, furnaces, boilers, and steam generators. While the ultimate composition of flue gas depends on the nature of the products being combusted in the energy generating apparatus or system, flue gas generally contains greenhouse gas compounds such as, but not limited to, sulfur oxides, nitrogen oxides, carbon dioxide, carbon monoxide, and water vapour, and other pollutants such as, but not limited to, hydrogen sulfide, heavy metals (e.g. mercury), soot, dust, smoke, and hazardous trace elements.

[0003] According to a survey administered by the Energy Information Administration (the "EIA") of 1900 power facilities in the United States of America, the power production distributions provided below were observed in 2015 [1]:

Table 1

Production Method	Percentage of overall Power Generation
Coal-fired combustion	About 35%
Gas-fired combustion	About 27%
Nuclear	About 21%
Hydro	About 6%
Wind	About 5%
Others including wood/wood waste, solar, geothermal, bio-gas consumption, etc...	Each about 1% or less

[0004] On a global perspective, the International Energy Agency (the “IEA”) recently estimated that nearly a third of the world's currently operating coal plants, most of which are aging subcritical plants, are slated to be retired over 2014-2040. Yet, the report also predicts that for each coal plant retired, the world will add about two more coal plants that will feature advanced Clean Coal technologies with carbon capture [2].

[0005] To address the growing concerns regarding greenhouse gas and heavy metal emissions and the effects of such greenhouse gas emissions on climate change, many jurisdictions around the world have begun implementing emission standards for their domestic energy producers to meet. For example, the 1990 *Clean Air Act Amendments* in the United States of America provide the legal guidance on the issue of air pollution control in the United States. In an effort to meet, and in some cases even exceed, such legislated emission standards, energy producers and researchers have focused at least some of their research efforts on identifying systems, techniques, and methods for removing greenhouse gases and other pollutants from emission streams (e.g. flue gas) before such polluting emissions are released into the atmosphere.

[0006] Greenhouse gases are atmospheric gases that absorb and emit infrared radiation. SO_x and NO_x species are examples of greenhouse gases and are produced in large quantities from the burning of fossil fuels; they are also major contributors to “acid rain”. Owing to their identified detrimental effects on the environment, industry standards now mandate that emission streams must be adequately removed of SO_x and NO_x species prior to release into the environment (including the atmosphere).

[0007] Sulfur dioxide (an example of a SO_x species) has traditionally been removed from flue gas through conventional limestone scrubbers utilizing the following underlying chemistry:



Conventional limestone scrubbers such as, but not limited to, FGD scrubbers generally have an SO₂ capture efficiency of about 90%. This efficiency may be improved to about 95% with the aid of additives. The remaining about 5+% of SO₂ that is not captured by conventional limestone scrubbers may be released into the atmosphere and may lead to the formation of health hazardous particulate matter (e.g. condensable PM, PM_{2.5}, PM₁₀) downwind of the flue gas emission. In 2008, the Environmental Protection Agency of the United States of America

issued a report showing that 211 counties distributed across 25 states in the United States of America failed to meet federal standards on fine-particle pollution [3]. Despite advances made in SO_x removal from emission streams, the residual amount of SO_x species that is released into the atmosphere still adversely impacts the environment.

[0008] In addition, the foregoing chemical reaction of sulfur dioxide and calcium carbonate produces carbon dioxide gas (*i.e.* a primary greenhouse gas) as a by-product which may be emitted into the atmosphere as a part of the flue gas emissions. For every ton of SO₂ captured by a limestone scrubber, about a ton of CO₂ is created. Limestone scrubbers also require large volumes of water to create a slurry to “scrub” SO_x species from flue gas, and therefore may operate at less than optimal efficiency in treatment plants situated in locations that experience or are prone to drought or drought-like conditions.

[0009] In an effort to decrease SO_x emissions, some energy producers have implemented “fuel-switching” programs, wherein high-sulfur coal is substituted by (or switched with) low-sulfur coal. However, such “fuel-switching” often requires changes to different parts of the energy producing facility in order to accommodate the new fuel. Such changes may include, but are not limited to, changes to boiler design and operating parameters or changes to coal grinding and handling techniques and methods. In addition, because low-sulfur coal has a lower BTU factor than high-sulfur coal, more low-sulfur coal would have to be consumed in order to produce the same level of energy that would otherwise be consumed by consuming high-sulfur coal. Such increased consumption of low-sulfur coal products increases the release of carbon dioxide gas and other pollutants into the atmosphere. In a non-limiting and illustrative example, a 500 MW coal-fired plant may have the following pollutant outputs (see Table 2 below) when fuel in the form of high-sulfur coal or in the form of low-sulfur coal is consumed:

Table 2

	High Sulfur Coal	Low Sulfur Coal
SO₂ output	about 302 tons/day	about 61 tons/day
NO_x output	about 36 tons/day	about 69 tons/day

CO ₂ output	about 10,850 tons/day	about 21,250 tons/day
------------------------	-----------------------	-----------------------

NO_x products in flue gas have traditionally been removed by conventional technologies including, but not limited to, boiler modifications and low-NO_x burners. However, industrial players are finding that conventional technologies do not have the ability to meet the increasingly stringent regulatory requirements regarding NO_x removal from flue gas. As such, some industrial players are turning to other technologies. For example, selective catalytic reduction (SCR) has been used to remove NO_x products from flue gas at an efficiency of about 90%. However, SCR processes require high temperatures and the injection of a reagent (e.g. ammonia) over a catalyst. Such a chemical environment may lead to undesirable events such as, but not limited to, catalyst poisoning or ammonia slip.

[0010] Nitric oxide (NO) is an example of a NO_x species. The reaction of NO in the gas phase with chlorine gas, bromine gas, or oxygen gas have been previously examined, and reported as being very slow, taking minutes to hours to equilibrate. On the other hand, oxidation of NO to nitrogen dioxide may occur rapidly in the presence of the appropriate species. For example, NO gas may be oxidized rapidly according to reactions 1, 2, and 3 below:

2. $\text{NO} + \text{O}_3 \rightarrow \text{NO}_2 + \text{O}_2$;
3. $\text{NO} + \text{ClO}_2 \rightarrow \text{NO}_2 + \text{ClO}$; and
4. $\text{NO} + \text{HNO}_3 \rightarrow \text{NO}_2 + \text{HNO}_2$.

Referring to reaction 2, NO has been shown to react completely with ozone in 0.6 seconds at 127°C [4]. Referring to reaction 3, and without being bound by theory, it is believed that the high endothermicity and instability of ClO₂ leads to the ready transfer of an oxygen atom to a molecule of NO. Referring to reaction 4, the reaction with HNO₃ has been used for NO removal from flue gas using HNO₃ vapour in the presence of chlorine gas, with 90% efficiency.

[0011] Heavy metal (e.g. mercury) removal from emission streams are conventionally done through activated carbon filter units. However, the activated carbon filter unit is an additional unit that would have to be incorporated into the flue gas treatment system and process design. In addition, heavy metals may also be inadvertently trapped in conventional limestone scrubbers, thereby contaminating the scrubbers and any downstream products (e.g. sludge or

gypsum) derived therefrom. It would be desirable to remove heavy metals like mercury within the same processes that remove SO_x and/or NO_x species, and to capture heavy metals with efficiency and low operating costs.

[0012] Examples of systems and methods for removing SO_x species, NO_x species, and heavy metals (e.g. mercury) from emission streams that are known in the art include, but are not limited to, examples provided in PCT App. No. PCT/CA1999/000403 and U.S. Pat. No. 4,619,608.

[0013] For example, mercury may be removed using a process that includes: scrubbing an oxidized flue gas stream (e.g. oxidized with chlorine gas) with water, or a water solution, of pH less than or equal to 7; and adding sufficient alkali metal halogen salt (e.g. alkali potassium iodide and the like) to precipitate mercury compounds (e.g. as mercuric iodide and the like) from the water or water solution of pH less than or equal to 7.

[0014] Four major gases contribute to the greenhouse effect in the troposphere:

Table 3

Greenhouse Gas	Percentage Contribution
Water Vapour	About 36-70% (depending on season)
Carbon dioxide gas	About 9-26%
Methane gas	About 4-9%
Ozone	About 3-7%

[0015] Water vapour has been identified as the most abundant greenhouse gas in the atmosphere, and yet is fairly poorly measured and understood [5]. Increases in atmospheric temperatures lead to increases in water evaporated from ground storage locations including, but not limited to, rivers, lakes, oceans, reservoirs, and soil. Warmer air temperatures also lead to higher absolute humidity (*i.e.* the warmer air has a greater capacity to “hold” more water than cooler air), thereby increasing the water content in the atmosphere. As a greenhouse gas, higher concentrations of water vapour means that more infrared energy radiating from the

Earth is absorbed and trapped in the atmosphere, thus further warming the atmosphere. It is desirable to remove water vapour from flue gas and to reuse or recycle the collected water vapour for other applications.

[0016] Flue gas generally contains a high water content. For example, the water content in flue gas generated from the combustion of high sulfur coal at a 500 MW coal-fired plant may be about 264,500 lb/hr, or about 8.8% by weight of the flue gas. By comparison, the water content in flue gas generated from the combustion of low sulfur coal at a 500 MW coal-fired plant may be about 1,106,390 lb/hr, or about 10.3% by weight of the flue gas. It is desirable to capture all or at least a portion of the water content in flue gas prior to emission.

[0017] Carbon dioxide is a greenhouse gas that is stable and does not burn or react readily with other compounds. Though essential for maintaining life on Earth, carbon dioxide is now concentrated in the Earth's atmosphere at unprecedented levels owing at least in part to anthropogenic emission sources such as, but not limited to, transportation, industrialization, fossil-fuel power production, deforestation, and plant destruction. Due to the growing concerns about climate change, carbon dioxide emissions have come under greater scrutiny by academic, industrial, and governmental players alike.

[0018] According to the EIA, in the United States alone, power generation is responsible for over 40% of the country's total CO₂ emissions. In 2008, that percentage of total CO₂ emission output amounted to about 2.5 billion metric tons. This number is continually growing [6].

[0019] Carbon dioxide gas may be converted into commercial products or removed from flue gas. For example, absorption and stripping processes involving aqueous solvents such as amines have been shown to remove carbon dioxide from emission streams such as, but not limited to, flue gas (see for example U.S. Pat. No. 4,477,419, U.S. Pat. No. 4,152,217, and U.S. Pat. No. 7,056,482). Carbon dioxide may also be removed by sodium and calcium based processes (see for example, U.S. App. No. 14/516,284, U.S. Pub. No. 2015/0231562, U.S. App. No. 14/491,015, U.S. Pub. No. 2013/0078159, and U.S. App. No. 14/383,320); however such designs likely add to the overall operating costs of an energy producing facility, if adopted. Carbon dioxide may also be converted to methane through hydrogenation (see for example, U.S. App. No. 14/302,594, U.S. Pat. No. 9,353,323, U.S. Pat. No. 9,267,211, U.S. Pat. No. 9,133,076, U.S. Pat. No. 9,090,978, US. App. No. 14/748,686, U.S. Pat. No. 8,754,269, and

U.S. App. No. 11/725,716). Carbon dioxide may also be removed from flue gas by burning an electropositive metal in the presence of carbon dioxide to reduce the carbon dioxide to carbon monoxide or elemental carbon (see for example U.S. Pat. No. 9,285,116). Carbon dioxide may also be removed from flue gas by cooling the flue gas by direct contact with a quench liquid (see for example U.S. App. No. 13/100,135). Mixed salt compositions may also be used as carbon dioxide sorbents for carbon dioxide removal from flue gas (see for example U.S. App. No. 14/415,283, U.S. App. No. 13/739,456, U.S. App. No. 13/869,405, and U.S. Pat. No. 9,101,876). Rare alkali earth metals may also be used for CO₂ capture processes such as carbonation of absorption processes; however, such processes are generally complicated, rely on chlor-alkali processes, and increase the operating costs of an energy producing facility. Carbon dioxide may also be removed by reaction with a suitable alkaline earth metal halide (e.g. MgCl₂ or CaCl₂) or suitable alkaline earth metal hydroxide halide (e.g. Mg(OH)Cl); however such processes require the addition of silicate minerals (e.g. calcium silicate, iron silicate, manganese silicate) as a separate step. The foregoing carbon dioxide conversion or removal processes require a carbon dioxide reactant that consists essentially of carbon dioxide. Pre-treatment of a carbon dioxide containing source (e.g. flue gas), and removing interfering species (e.g. SO_x, NO_x) therefrom, would be required.

[0020] Carbon dioxide gas may be converted into methane gas by the Sabatier process. The Sabatier process involves the hydrogenation of CO₂ in the presence of a catalyst (e.g. a nickel catalyst, ruthenium, or alumina) to produce methane, water, and energy. The reaction can be summarized as follows [7]:

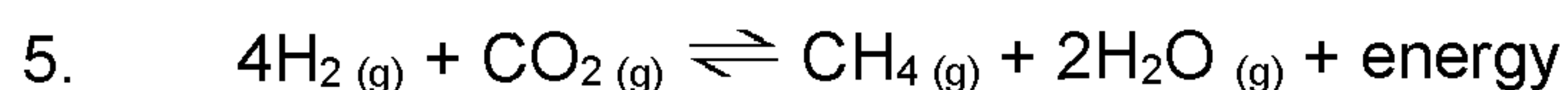

The produced methane from the Sabatier reaction may then be used as a source of fuel in downstream applications. The Sabatier reaction is recognized as a potential means of removing and utilizing carbon dioxide emissions from fossil fuel combustion. However, in order for the Sabatier process to be economically viable as an industrial method of removing and utilizing carbon dioxide emissions from fossil fuel combustion, large amounts of hydrogen gas would need to be produced and/or be available at relatively low cost. To date, the Sabatier reaction has not seen widespread application in industrial settings owing to these requirements/limitations.

[0021] Conversion of carbon dioxide into a useful hydrocarbon fuel (e.g. methane) may be desirable. Methane is important for electrical generation, and may be used as a fuel in gas turbines or steam generators. Compared to other hydrocarbon fuels, methane produces less carbon dioxide for each unit of heat released. For example, at about 891 kJ/mol, methane's heat of combustion is lower than any other hydrocarbon but the ratio of the heat combustion (891 kJ/mol) to the molecular mass (16.0 g/mol of which 12.0 g/mol is carbon) shows that methane, being the simplest hydrocarbon, produces more heat per mass unit (55.7 kJ/mol) than other complex hydrocarbons. Methane may be used in various chemical processes, or as a fuel for homes and automobiles in the form of compressed natural gas which may be more environmentally friendly than other fuel sources like gasoline/petrol and diesel.

[0022] Liquefied Natural Gas (LNG) is predominantly methane that has been converted to liquid form for ease of storage or transport. The methane is condensed into a liquid at about atmospheric pressure. LNG takes up about 1/600 the volume of natural gas in the gaseous state. It is odorless, colorless, non-toxic and non-corrosive. LNG achieves a higher reduction in volume than compressed natural gas (CNG). The energy density of LNG may be 2.4 times greater than that of CNG or may be about 60% that of diesel fuel. LNG is generally cost efficient to transport over long distances where pipelines do not exist. Specifically designed cryogenic sea vessels (LNG carriers) or cryogenic road tankers may be used for LNG transport.

[0023] No admission is necessarily intended, nor should it be construed, that any of the preceding information constitutes prior art against the present invention.

SUMMARY:

[0024] Various embodiments of this disclosure relate to a system comprising: (a) a reactor configured to receive a gas stream comprising NO_x species and carbon dioxide gas, the reactor further configured to oxidize the NO_x species in the gas stream to produce hydrochloric acid; (b) an electrolytic unit configured to receive the hydrochloric acid and configured to electrolyse the hydrochloric acid to produce hydrogen gas; and (c) a carbon dioxide absorber (e.g. a "Sabatier reactor") configured to receive the gas stream from the reactor and the hydrogen gas from the electrolytic unit, the hydrogen gas for hydrogenating the carbon dioxide gas in the gas stream into a hydrocarbon fuel.

[0025] The carbon dioxide gas may be converted to the hydrocarbon fuel by the Sabatier reaction.

[0026] The Sabatier reaction may use a catalyst selected from the group consisting of a nickel catalyst, a ruthenium catalyst, an alumina catalyst, and a copper catalyst.

[0027] Various embodiments of this disclosure relate to a system comprising: (a) a gas phase reactor configured to receive a gas stream comprising NO_x species, water vapour, and carbon dioxide gas, the gas phase reactor further configured to oxidize the NO_x species in the gas stream to produce hydrochloric acid; (b) a NO_x absorber configured to receive the gas stream from the gas phase reactor, the NO_x absorber further configured to oxidize the NO_x species in the gas stream, the NO_x absorber further configured to collect the hydrochloric acid produced from oxidizing the NO_x species in the gas stream in the NO_x absorber and oxidizing the NO_x species in the gas phase reactor; (c) an electrolytic unit configured to receive the hydrochloric acid collected at the NO_x absorber, and further configured to electrolyse the hydrochloric acid to produce hydrogen gas; (d) a water vapour remover configured to receive the gas stream from the NO_x absorber, and further configured to remove the water vapour from the gas stream; and (e) a carbon dioxide absorber configured to receive the gas stream from the water vapour removal apparatus and the hydrogen gas from the electrolytic unit, the hydrogen gas for hydrogenating the carbon dioxide gas in the gas stream into a hydrocarbon fuel.

[0028] Various embodiments of this disclosure relate to a method of treating a gas stream comprising NO_x species, water vapour, and carbon dioxide gas, the method comprising: (a) generating hydroxyl radicals and chlorine radicals; (b) oxidizing the NO_x species in the gas stream with the hydroxyl radicals and chlorine radicals to produce nitric acid and hydrochloric acid; (c) removing the water vapour from the gas stream; (d) reacting the carbon dioxide gas with hydrogen gas produced from electrolyzing the water vapour removed from the gas stream, the hydrochloric acid, or both, to produce a hydrocarbon fuel.

[0029] Various embodiments of this disclosure relate to a system comprising: (a) a gas phase oxidation (GPO) reactor configured to receive a flue gas stream comprising NO_x species and carbon dioxide gas, the GPO reactor further configured to receive chlorine gas, liquid or solution, and to oxidize the NO_x species in the flue gas stream to produce a gas stream comprising nitric acid and hydrochloric acid; (b) an electrolytic unit configured to receive the

hydrochloric acid and configured to electrolyse the hydrochloric acid to produce hydrogen gas and chlorine gas; and (c) a Sabatier reactor configured to receive both a gas stream, downstream from the GPO reactor, and at least a portion of the hydrogen gas from the electrolytic unit, the Sabatier reactor further configured to hydrogenate the carbon dioxide gas in the gas stream into a hydrocarbon fuel comprising methane.

[0030] Various embodiments of this disclosure relate to a method of producing a hydrocarbon fuel, comprising methane, from a flue gas stream comprising NO_x species, water vapour, and carbon dioxide gas, the method comprising: (a) generating hydroxyl radicals and chlorine radicals; (b) oxidizing the NO_x species in the gas stream with the hydroxyl radicals and chlorine radicals to produce a gas stream comprising nitric acid and hydrochloric acid, water vapour and carbon dioxide gas; (c) removing the water vapour from the gas stream to produce a dehydrated gas stream; (d) producing hydrogen gas from one or both of: (di) electrolyzing the water vapour removed from the gas stream in (c); and (dii) electrolyzing the hydrochloric acid produced in (b); (e) using a Sabatier reaction to hydrogenate the carbon dioxide gas in the dehydrated gas stream from (c) with the hydrogen gas produced in (d) to produce the hydrocarbon fuel.

[0031] According to another aspect of the disclosure, there is a use of the Sabatier reaction for converting carbon dioxide gas into a hydrocarbon fuel in an industrial-size flue gas treatment system.

[0032] This summary does not necessarily describe the entire scope of all aspects of the disclosure. Other aspects, features and advantages will be apparent to those of ordinary skill in the art upon review of the following description of specific embodiments.

BRIEF DESCRIPTION OF THE DRAWINGS:

[0033] In the accompanying drawings, which illustrate one or more exemplary embodiments:

[0034] FIGURE 1 is a flue gas treatment system for use in a coal-firing facility according to an embodiment, the treatment system comprising a gas phase reactor, a SO_x absorber, a NO_x absorber, a water vapour remover, and a carbon dioxide absorber.

[0035] FIGURE 2 is a schematic of a flue gas treatment system for use in a gas-burning facility

according to another embodiment, the treatment system comprising a gas phase reactor, a NO_x absorber, a water vapour remover, and a carbon dioxide absorber.

DETAILED DESCRIPTION:

[0036] Directional terms such as “top”, “bottom”, “upwards”, “downwards”, “vertically”, and “laterally” are used in the following description for the purpose of providing relative reference only, and are not intended to suggest any limitations on how any article is to be positioned during use, or to be mounted in an assembly or relative to an environment.

[0037] Any element expressed in the singular form also encompasses its plural form. Any element expressed in the plural form also encompasses its singular form. The use of the word “a” or “an” when used herein in conjunction with the term “comprising” may mean “one”, but it is also consistent with the meaning of “one or more”, “at least one”, and “one or more than one”.

[0038] As used herein, the terms “comprising”, “having”, “including”, and “containing”, and grammatical variations thereof, are inclusive or open-ended and do not exclude additional, unrecited elements and/or method steps. The term “consisting essentially of” when used herein in connection with a composition, use or method, denotes that additional elements, method steps or both additional elements and method steps may be present, but that these additions do not materially affect the manner in which the recited composition, method or use functions. The term “consisting of” when used herein in connection with a composition, use or method, excludes the presence of additional elements and/or method steps.

[0039] As used herein, the term “about” when followed by a recited value means plus or minus 10% of the recited value.

[0040] The present disclosure relates to a system and a method for removing greenhouse gases and other pollutants from an emission stream (e.g. flue gas). Greenhouse gases and other pollutants may include, without limitation, one or more of: SO_x (e.g. SO₂), NO_x (e.g. NO, NO₂), H₂S, water vapour, carbon dioxide, heavy metals (e.g. mercury), soot, smoke, dust, and trace elements.

[0041] The present disclosure also relates to systems and methods for removing water vapour and carbon dioxide gas from the emission stream (e.g. flue gas), and for converting the carbon

dioxide gas into a hydrocarbon fuel via the Sabatier process. It is contemplated that the system may be able to internally produce a large enough volume of hydrogen gas to drive the Sabatier process and remove carbon dioxide gas from the emission stream. It is also contemplated that the Sabatier process may be incorporated into an industrial scale setting and be economically competitive against conventional emission stream treatment methods.

[0042] Emission streams may be pre-cleaned through an electrostatic precipitator (an "ESP"), as known in the art, to remove fine particles such as, but not limited to, dust, soot, smoke, and trace elements. Trace elements include, but are not limited to, antimony, arsenic, cadmium, chromium, nickel, selenium, and zirconium, all of which have been identified as elements that have detrimental impacts on the environment and human health. However, even if the ESP operates at about 99% efficiency, a portion of these trace elements pass through the ESP. The remaining trace elements are captured in sulfuric acid produced by the oxidation of SO_x species (described below) where they may be removed by ion exchange.

[0043] NO_x species in the emission stream may be oxidized to produce hydrochloric acid and nitric acid. The produced nitric acid may be sold as is, and the produced hydrochloric acid may be electrolyzed to produce hydrogen gas and chlorine gas. The hydrogen gas may be used to hydrogenate the carbon dioxide gas present in the flue gas to a hydrocarbon fuel. The chlorine gas may be used to generate chlorine radicals required in the oxidation of SO_x species, NO_x species, and heavy metals (e.g. mercury) present in the emissions stream.

[0044] Water vapour in the emission stream may be removed from the emission stream and electrolyzed to form hydrogen gas and oxygen gas. The hydrogen gas may be used to hydrogenate the carbon dioxide gas present in the emission stream to a hydrocarbon fuel. The oxygen gas may be directed to a furnace of the system to aid in combustion or sold.

[0045] The hydrocarbon fuel produced from the hydrogenation of carbon dioxide via, for example, the Sabatier process may be condensed further to reduce gas volumes and to aid in storage and transport. In some instances, produced hydrocarbon fuel may be condensed up to about 600%.

[0046] Thus, various embodiments of the present disclosure relate to a system, e.g. a flue gas treatment system configured for use with a coal-firing facility or a gas-burning facility. The system includes, at a minimum: (a) a gas phase oxidation (GPO) reactor (referred elsewhere

herein as a "gas phase reactor"), (b) an electrolytic unit, and (c) a Sabatier reactor (also referred to herein as a "carbon dioxide absorber"). The flue gas may be from a coal-firing plant or a gas-burning plant, or from any other flue gas source. In some embodiments, the flue gas will have been pre-cleaned as described above (e.g. through an ESP). The flue gas comprises NO_x species (e.g. NO , NO_2), and carbon dioxide gas and may further comprise one or more of: water vapour, SO_x species (e.g. SO_2), mercury and/or heavy metal trace elements. In some embodiments, the flue gas comprises SO_x species, NO_x species, water vapour, mercury, carbon dioxide gas and may further comprise heavy metal trace elements.

[0047] In some embodiments, the system further includes water vapour remover. In some embodiments, the system further includes a NO_x absorber. In some embodiments, the system further includes a SO_x absorber. In some embodiments, the system includes: a GPO reactor, a SO_x absorber, a NO_x absorber, an electrolytic unit, a water vapour remover and a Sabatier reactor. Primary products of these systems are nitric acid and methane, the latter of which may be used on site, stored compressed or converted to liquefied natural gas (LNG). For any of the above embodiments, the system may thus further comprise a compressor for compressing the methane or a condenser for condensing the methane into LNG. Depending on the components of the flue gas, other products of these systems may include sulfuric acid and/or mercury. HCl and $\text{H}_2(\text{g})$ are also produced, and in certain embodiments may be recycled into the system. $\text{O}_2(\text{g})$ may also be produced, and in certain embodiments may be recycled into the system.

[0048] The GPO reactor is configured to receive a flue gas stream, and is further configured for oxidation of the NO_x species in the flue gas. In some embodiments, for example, the GPO reactor is configured to further receive chlorine (as gas, a liquid or in solution), which oxidizes the NO_x species in the flue gas to produce a gas stream (i.e. a product gas stream) which comprises, among other things, nitric acid and hydrochloric acid.

[0049] In some embodiments, the chlorine is a chlorine gas and the GPO reactor is configured to receive a chlorine gas stream. In such embodiments, chlorine gas and flue gas may be: (i) delivered into the GPO reactor operating at pre-set reaction conditions; and (ii) mixed in the GPO reactor. The GPO reactor may be a reactor that is known in the art, such as a commercially available gas phase reactor that can adequately mix the gases. Appropriate reaction conditions are also known in the art (see for example U.S. Pat. No. 4,619,608). For example, the GPO reactor may be set at a temperature between about 100°C and about

650°C. For example, the temperature of the GPO reactor may be set at about 100°C, 125°C, 150°C, 175°C, 200°C, 225°C, 250°C, 275°C, 300°C, 325°C, 350°C, 375°C, 400°C, 425°C, 450°C, 475°C, 500°C, 525°C, 550°C, 575°C, 600°C, 625°C, 650°C, or any temperature therebetween.

[0050] At elevated temperatures in the GPO reactor, it is believed that chlorine gas reacts with water vapour in the flue gas to generate chlorine radicals and hydroxyl radicals. The NO_x species or a portion thereof present in the flue gas is oxidized in the GPO reactor in the presence of the generated chlorine radicals and the generated hydroxyl radicals. Using nitric oxide (NO) as a non-limiting example of a NO_x species, and without wishing to be bound by theory, it is believed that nitric oxide (NO) in flue gas is oxidized to nitric acid (HNO₃) and hydrochloric acid in the GPO reactor according to the following chemical reactions:

6. $\text{NO} + \cdot\text{OH} \rightarrow \text{HNO}_2$;
7. $\text{NO} + \cdot\text{Cl} \rightarrow \text{NOCl}$;
8. $\text{NOCl} + \text{H}_2\text{O} \rightarrow \text{HNO}_2 + \text{HCl}$;
9. $\text{HNO}_2 + \cdot\text{Cl} \rightarrow \text{NO}_2 + \text{HCl}$;
10. $\text{NO}_2 + \cdot\text{OH} \rightarrow \text{HNO}_3$;
11. $\text{NO}_2 + \cdot\text{Cl} \rightarrow \text{NO}_2\text{Cl}$;
12. $\text{NO}_2\text{Cl} + \text{H}_2\text{O} \rightarrow \text{HNO}_3 + \text{HCl}$.

[0051] Without being bound by theory, it is also believed that the oxidized forms of polluting species are more readily removable from flue gas than the non-oxidized forms thereof. In addition, it is believed that the predominant final products of NO_x removal are nitric acid and hydrochloric acid. The gas stream exiting the GPO reactor (i.e. the product gas stream) thus comprises dissolved nitric acid and hydrochloric acid and other pollutants (e.g. CO₂ (g)), and in some cases one or more of water vapour, sulfuric acid, HgCl₂, trace heavy metals, and may further include remaining non-oxidized NO_x species, SO_x species, and/or non-chlorinated mercury.

[0052] The product gas stream may be substantially free of NO_x species or may benefit from further oxidation to yield a product gas stream that is substantially free of NO_x species. When present in the flue gas, SO_x species will also be oxidized in the GPO reactor, forming sulfuric acid. In such case, the product gas stream may be substantially free of SO_x species or may benefit from further oxidation to yield a product gas stream that is substantially free of SO_x species.

[0053] For example, in some embodiments (e.g. when the flue gas comprises SO_x species), the system may further comprise a SO_x absorber configured to receive the product gas stream from the GPO reactor or a further processed gas stream, downstream from the GPO reactor. Such systems may further include a NO_x absorber. For example, the SO_x absorber may be positioned in series between the NO_x absorber and the GPO reactor. In some embodiments, the system further includes a SO_x absorber and does not include a NO_x absorber. For example, the SO_x absorber may be positioned in series between the GPO reactor and the Sabatier reactor, or between the GPO reactor and a water vapour remover.

[0054] In embodiments that further comprise a SO_x absorber, SO_x absorber may be configured to receive the product gas stream from the GPO reactor or a further processed gas stream, downstream from GPO reactor, and may be further configured to collect from the gas stream the oxidized SO_x species converted in the GPO reactor.

[0055] The SO_x absorber may be any suitable absorber that is known in the art. For example, the SO_x absorber may be one that is substantially similar to the one described in U.S. Pat. No. 4,619,608 both in design and reaction conditions. The SO_x absorber may achieve SO₂ capture rates of above 99% without producing CO₂ as a by-product. Where CO₂ capture and storage by sequestration is desired, SO_x limits of 10 ppm or below may be required. Conventional limestone scrubbers may not remove SO₂ from flue gas with the same efficiency.

[0056] The SO_x absorber may be arranged horizontally or vertically, depending on spatial restrictions or requirements of the system. The SO_x absorber may also comprise packed towers or cross-flow vessels that condense and collect one or more resulting acid streams, e.g. one or more of sulfuric acid, nitric acid, hydrochloric acid, and/or other acid streams, and may further collect as mercury products and/or trace heavy metal products. The SO_x absorber may be a single integrated absorber or consist of a plurality of non-integrated components. The SO_x

absorber may be a single SO_x absorber unit, or may comprise a plurality of SO_x absorber units.

[0057] In addition to oxidizing NO_x species, the conditions in the GPO reactor also oxidize SO_x species. In the SO_x absorber, additional solution chemistry may occur to aid in oxidation and/or collection and to build up the strengths of the acids. For example, but without limitation, water may be circulated in the SO_x absorber or steam may be sprayed into the SO_x absorber. This oxidation process converts SO_x species to sulfuric acid so as to convert the remaining SO_x species to sulfuric acid. In the presence of steam, SO_x generally reacts in preferential order over NO_x. Using sulfur dioxide (SO₂) as a non-limiting example of a SO_x species, and without wishing to be bound by theory, it is believed that the sulfur dioxide is oxidized to sulfuric acid (H₂SO₄) in the SO_x absorber according to the following chemical reaction:



SO₂ removal rates of about 99% may be achieved at Cl₂ levels as low as 1.0 Cl₂/SO₂ molar ratio. An equilibrium concentration of about 70% or higher H₂SO₄ to H₂O may also be achieved. The collected mixture of H₂SO₄/H₂O may be further treated by a process to remove H₂O, thereby concentrating the remaining sulfuric acid to a purity of up to about 93-96% (commercial grade). The purified H₂SO₄ may then be collected and shipped to industry for sale. Accordingly, in certain embodiments, the system may further comprise means for removing water from the mixture of H₂SO₄/H₂O.

[0058] In some embodiments (e.g. when the flue gas further comprises mercury), the SO_x absorber may be further configured to remove the mercury. For example, but without limitation, the HgCl₂ produced by halogenation reaction in the GPO reactor, and/or produced in the SO_x absorber itself, may be captured in the condensed sulfuric acid that is collected by the SO_x absorber. The SO_x absorber may be further configured to convert metallic mercury remaining in the gas stream to HgCl₂ and to collect the produced HgCl₂. Mercuric halides (e.g. mercuric chloride) in the sulfuric acid (wherever produced) may be separated out using various methods, e.g. but not limited to, any described in PCT/CA1999/000403. In one non-limiting example, an alkali metal halogen (e.g. potassium iodide) salt is added to precipitate mercuric iodide (see PCT/CA1999/000403). In other embodiments, the system may not be configured for heavy metal removal. Yet in other embodiments, mercury recovery from the collected sulfuric acid may occur at an off-site location.

[0059] In some embodiments (e.g. when the flue gas further comprises at least one heavy metal trace element), the SO_x absorber or the system may be further configured to remove the at least one heavy metal trace element (e.g. one or more of antimony, arsenic, cadmium, chromium, nickel, selenium, and zirconium). For example, but without limitation, the trace elements may be captured in the sulfuric acid produced from oxidizing the SO_x species and condensed in the SO_x absorber. In some embodiments, the system further comprises means for removing the trace elements from the sulfuric acid by ion exchange. In other embodiments, trace element removal may not occur. Yet in other embodiments, trace element removal may occur at an off-site location.

[0060] As discussed, in some embodiments the system may further comprise a NO_x absorber configured to receive the product gas stream from the GPO reactor or a further processed gas stream, downstream from the GPO reactor (e.g. a gas stream exiting a SO_x absorber). As discussed, such systems may further include a SO_x absorber. For example, the NO_x absorber may be positioned in series between the SO_x absorber and the Sabatier reactor, or between the SO_x absorber and a water vapour remover. In some embodiments, the system further includes a NO_x absorber and does not include a SO_x absorber. For example, the NO_x absorber may be positioned in series between the GPO reactor and the Sabatier reactor, or between the GPO reactor and a water vapour remover.

[0061] The NO_x absorber is further configured to collect oxidized NO_x species converted in the GPO reactor. The NO_x absorber may be any absorber that is known in the art to be suitable for this purpose. For example, the NO_x absorber may be one that is substantially similar to the one described in U.S. Pat. No. 4,619,608 both in design and reaction conditions. NO_x removal efficiency of about 98% may be achieved by the combination of a GPO reactor and a NO_x absorber. When no ammonia is used in a NO_x absorber, there is no ammonia slip. The NO_x absorber may be arranged horizontally or vertically, depending on spatial restrictions or requirements of the system. The NO_x absorber may also comprise packed towers or cross-flow vessels that condense and collect nitric acid, hydrochloric acid, as well as heavy metal products (e.g. HgCl₂). In some embodiments, the NO_x absorber is a plurality of NO_x absorber units. In some embodiments, the NO_x absorber may be a single NO_x absorber unit.

[0062] In some embodiments, the NO_x absorber may be further configured to further oxidize NO_x species that may remain in the product gas stream (e.g. from the GPO reactor) or in the

further treated gas stream (e.g. from the SO_x reactor), so as to convert the remaining NO_x species to nitric acid and hydrochloric acid. For example, the gas stream entering the NO_x absorber may be sprayed with steam to further oxidize the NO_x species. The gas stream may be sprayed with steam at a non-zero angle (e.g. orthogonally). The gas stream may be sprayed with steam at a suitable spraying pressure. Without being bound by theory, it is believed that the following reactions are involved in the removal of NO_x species from gas stream in the NO_x absorber:

14. $\text{Cl}_2 + \text{H}_2\text{O} \rightarrow \text{HOCl} + \text{HCl}$
15. $\text{NOCl} + \text{H}_2\text{O} \rightarrow \text{HNO}_2 + \text{HCl}$
16. $\text{NOCl} + \text{HOCl} + \text{H}_2\text{O} \rightarrow \text{HNO}_3 + 2\text{HCl}$
17. $\text{NO}_2\text{Cl} + \text{H}_2\text{O} \rightarrow \text{HNO}_2 + \text{HOCl}$
18. $2\text{NO}_2 + \text{H}_2\text{O} \rightarrow \text{HNO}_2 + \text{HNO}_3$
19. $\text{HNO}_2 + \text{HOCl} \rightarrow \text{HNO}_3 + \text{HCl}$
20. $2\text{NO} + \text{H}_2\text{O} + \text{HNO}_3 \rightarrow 3\text{HNO}_2$

It is thus believed that the predominant final products of NO_x removal are nitric acid and hydrochloric acid.

[0063] The NO_x absorber may collect nitric acid having a purity of up to about 99% that may be directed to further processing and/or storage in preparation for commercial shipment and/or sale.

[0064] In certain embodiments, the NO_x absorber is configured to remove mercury and/or heavy metal trace elements, using equipment and process(es) known in the art, e.g. but not limited to those described in PCT/CA1999/000403 or described elsewhere herein.

[0065] In some embodiments, the NO_x absorber may be configured to collect the hydrochloric acid and to direct at least a portion of the hydrochloric acid from the NO_x absorber to the electrolytic unit. At the electrolytic unit, the HCl undergoes electrolysis to produce hydrogen gas and chlorine gas. Methods of electrolysing hydrochloric acid are known in the art, and any

suitable commercially available electrolytic unit may be used. In a non-limiting example, the electrolytic unit comprises high temperature electrolysis cells. The electrolytic unit is thus configured to receive the hydrochloric acid (e.g. from the NO_x absorber, or a portion of which is from the NO_x absorber) and is further configured to electrolyse the hydrochloric acid to produce both hydrogen gas and chlorine gas. In alternative embodiments, the system may be configured to direct HCl separated from the condensed products of the SO_x absorber to the electrolytic unit.

[0066] The hydrogen gas produced from the electrolysis of HCl at the electrolytic unit may be re-used in the system or elsewhere in the plant, or potentially stored, e.g. for sale/transport. In a non-limiting example, the produced hydrogen gas or a portion thereof is re-directed to the Sabatier reactor for use in converting carbon dioxide gas into a hydrocarbon fuel. The chlorine gas produced from the electrolysis of HCl at electrolytic unit (or a portion thereof) may be re-used in the system or elsewhere in the plant, or potentially stored, e.g. for sale/transport. In a non-limiting example, the system is further configured to direct the chlorine gas produced in the electrolytic unit to supply all or a portion of the chlorine gas stream for GPO reactor.

[0067] In some embodiments, the system may be configured such that the product gas stream leaving the GPO reactor is fed directly to the Sabatier reactor. In other embodiments, additional components (e.g. SO_x absorber(s), NO_x absorber(s) and/or water vapour remover(s)) to treat the product gas stream are included in series between the GPO reactor and the Sabatier reactor to treat (further process or clean) the gas stream for a more efficient Sabatier reaction.

[0068] For example, in some embodiments (e.g. when the flue gas further comprises water vapour), the system further comprises a water vapour remover configured to remove the water vapour from the gas stream before reaching the Sabatier reactor. The water vapour remover may be positioned in series in the system between the NO_x absorber and the Sabatier reactor. The water vapour remover may be positioned in series between the SO_x absorber and the Sabatier reactor. The water vapour remover may be positioned in series between the GPO reactor and the Sabatier reaction, e.g. immediately prior to receiving the treated gas stream at Sabatier reactor. The water vapour remover may be configured in parallel to the electrolytic unit.

[0069] Any suitable water vapour remover may be used, as is well known in the art. In a non-

limiting example, thermal energy generated from the system itself (e.g. heat from excess steam, or heat added specifically for the step of water vapour removal is used to heat the gas stream to evaporate any H₂O content remaining therein, the evaporated H₂O content being collectable downstream. In another non-limiting example, water vapour is removed from the gas stream by heat exchangers and the removed water vapour may be collected as steam. Without such treatment or removal step, the water vapour generally would otherwise be vented into the atmosphere. The system may be configured to use the collected steam or to condense the steam to liquid water (e.g. by cooling). Accordingly, in certain embodiments, the system may be further configured to recycle the collected water content (steam or liquid water) back into the system. For example, but without limitation, the system may be configured to: (i) return the H₂O content to a steam cycle of the system; (ii) re-use the H₂O content recovered from the gas stream as process water in the SO_x absorber (if present), the NO_x absorber (if present), or both the SO_x absorber and the NO_x absorber; (iii) use the H₂O content recovered from the gas stream to aid in the electrolysis of HCl in the electrolytic unit; and/or (iv) use the H₂O content recovered from the gas stream as a heat source to increase the temperature of the electrolytic reaction of HCl in the electrolytic unit, thereby improving the efficiency of electrolysis. Such recycling of evaporated H₂O content from flue gas may be desired, particularly for flue gas treatment systems that are situated in locations that experience or are prone to drought or drought-like conditions. It is estimated that, for a 500 MW plant, up to about 750,000 lbs/hr of H₂O content that would otherwise be vented into the atmosphere as steam may be recovered and re-used within the system herein.

[0070] In some embodiments, the system is configured to direct the H₂O content collected in the water vapour remover (or a portion thereof) to a separate water electrolytic unit configured to convert the water to hydrogen gas and oxygen gas. In these embodiments, the system may be configured to direct the hydrogen gas generated from the electrolysis of the collected H₂O content (or a portion thereof) to the Sabatier reactor. The system may be further configured to use the oxygen gas generated from the electrolysis as a fuel source within the system or elsewhere in the plant. In other embodiments, the collected water content removed from the gas stream in the water vapour remover does not undergo further hydrolysis.

[0071] The water vapour remover is configured to direct the resulting dehydrated gas stream (comprising CO₂ gas or consisting essentially of CO₂ gas) to the Sabatier reactor.

[0072] The Sabatier reactor is configured to receive a gas stream (i.e. the product gas stream of the GPO reactor or a further treated gas stream downstream from the GPO reactor) and is further configured to receive a hydrogen gas stream (e.g. from one or more electrolytic units electrolyzing HCl and/or water). For example, the Sabatier reactor may be configured to receive a gas stream from the SO_x absorber, the NO_x absorber or the water vapour remover. In certain embodiments, the Sabatier reactor is configured to receive a gas stream from the water vapour remover.

[0073] The Sabatier process is catalyzed in the Sabatier reactor by an appropriate catalyst such as, but not limited to, a nickel catalyst, ruthenium, alumina, or a copper catalyst. In certain embodiments, the catalyst is a copper catalyst. In certain embodiments, the Sabatier reactor is configured for the Sabatier reaction to occur at atmospheric pressure. In some embodiments, the molar feed ratio of H₂:CO₂ is greater than or equal to about 3.5:1, and the Sabatier process may be carried out at a temperature between about 400°F and about 700°F. In other embodiments, other suitable reaction parameters may be used. Any suitable Sabatier reactor and conditions may be used.

[0074] In the Sabatier reactor, the Sabatier reaction hydrogenates the carbon dioxide gas in the product gas stream into a hydrocarbon fuel. In some embodiments, the hydrocarbon fuel comprises methane. In some embodiments, the hydrocarbon fuel consists essentially of methane.

[0075] In some embodiments, the system may be further configured to direct the methane (or a portion thereof) to a boiler or combustion chamber configured to combust the methane to generate heat or power. For example, the methane (or a portion thereof) may be blended and co-fired with coal at the plant, or may be used as a fuel to power a separate turbine. In some embodiments, the system may further comprise a compressor or condenser configured to condense liquefied natural gas from the methane (or a portion thereof). In some embodiments, the system may further comprise a compressor configured to condense the volume of the hydrocarbon fuel, e.g. for transport from the plant.

[0076] In other non-limiting examples, the system may be further configured to convert the methane (or a portion thereof) to other products such as, but not limited to, a methyl halide. In a non-limiting example, methane (or a portion thereof) may be converted to chloromethane

through the following reaction, as known in the art:

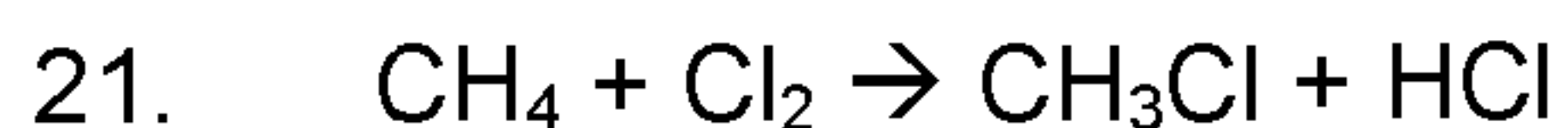

[0077] The resulting methyl chloride may be further processed into other organic polyhalides, such as dichloro-methane. The resulting methyl chloride may also be converted to other products like methyl alcohols, ethyl alcohols, ethers, aldehydes, ketones, organic acids, esters, amines, and fats and soaps.

[0078] In various embodiments, the system may comprise: (a) a GPO reactor configured to receive a gas stream comprising SO_x species, NO_x species, water vapour, heavy metals, and carbon dioxide gas, the GPO reactor further configured to oxidize the SO_x species and NO_x species; (b) a SO_x absorber configured to receive the gas stream from the GPO reactor, the SO_x absorber further configured to further oxidize and collect the SO_x species as H_2SO_4 ; (c) a NO_x absorber configured to receive the gas stream from the SO_x absorber, the NO_x absorber further configured to further oxidize the NO_x species in the gas stream, the NO_x absorber further configured to collect hydrochloric acid produced from oxidizing the NO_x species; (d) an electrolytic unit configured to receive the hydrochloric acid collected at the NO_x absorber, and further configured to electrolyse the hydrochloric acid to produce hydrogen gas; (e) a water vapour remover configured to receive the gas stream from the NO_x absorber, and further configured to remove water vapour from the gas stream; and (f) a Sabatier reactor configured to receive the gas stream from the water vapour remover and the hydrogen gas from the electrolytic unit, the hydrogen gas for hydrogenating the carbon dioxide gas in the gas stream into a hydrocarbon fuel comprising methane.

[0079] The present disclosure also relates to a method of producing a hydrocarbon fuel from a flue gas stream comprising NO_x species, water vapour, and carbon dioxide gas. Without limitation, the flue gas may be from a coal-firing facility or a gas-burning facility. As such, the flue gas may further comprise SO_x species, mercury, and/or heavy metal trace elements. In some embodiments, the flue gas will have been pre-cleaned as described above (e.g. through an ESP). In some embodiments, the hydrocarbon fuel comprises methane. In some embodiments, the hydrocarbon fuel consists essentially of methane.

[0080] The method comprises: (a) generating hydroxyl radicals and chlorine radicals; (b) oxidizing the NO_x species in the gas stream with the hydroxyl radicals and chlorine radicals to

produce a gas stream comprising nitric acid and hydrochloric acid, water vapour and carbon dioxide gas; (c) removing the water vapour from the gas stream to produce a dehydrated gas stream; (d) producing hydrogen gas from one or both of: (di) electrolyzing the water vapour removed from the gas stream in step (c) to produce hydrogen gas and oxygen gas; and (dii) electrolyzing the hydrochloric acid produced in step (b) to produce hydrogen gas and chlorine gas; (e) using a Sabatier reaction to hydrogenate the carbon dioxide gas in the dehydrated gas stream from (c) with the hydrogen gas produced in step (d) to produce the hydrocarbon fuel.

[0081] In embodiments where the flue gas stream further comprises SO_x species, the method may further comprise step (bi) oxidizing the SO_x species (e.g. using the hydroxyl radicals and and/or chlorine radicals from step (a), and/or by using steam or water) to produce sulfuric acid, and removing the sulfuric acid from the gas stream (e.g. using a SO_x absorber as described for the system above) to produce a gas stream that is substantially free of SO_x species. In embodiments where the flue gas stream further comprises heavy metal trace elements (e.g. but not limited to, one or more selected from a group consisting of antimony, arsenic, cadmium, chromium, nickel, selenium, zirconium, and/or any combination thereof), the method further may further comprise removing the trace elements from the gas stream by capturing the trace elements in the sulfuric acid (as described for the system above). In certain embodiments, but without limitation, the trace elements may be removed from the sulfuric acid by ion exchange. In embodiments where the flue gas stream further comprises mercury, the method may further comprise removing the mercury from the gas stream (as described for the system above). In certain embodiments, removing the mercury comprises converting the mercury to HgCl_2 and capturing the HgCl_2 in sulfuric acid (e.g. collected in a SO_x absorber). The method may further comprise recovering the mercury from the sulfuric acid (as described for the system above). For example, but without limitation, the mercury may be removed from the sulfuric acid by precipitating out mercury by adding an alkali metal halogen (e.g. potassium iodide to precipitate out mercuric iodide (see PCT/CA1999/000403)).

[0082] In certain embodiments, the method may further comprise step (bii) further oxidizing the NO_x species with steam or water to produce hydrochloric acid and a gas stream that is substantially free of NO_x species (e.g. by passing the gas stream through a NO_x absorber as described above). In certain embodiments of the method that comprise step (dii), i.e. electrolyzing the hydrochloric acid produced from step (a) and/or step (bii) to produce hydrogen

gas and chlorine gas, the method may further comprise using the chlorine gas from step (dii) to generate at least some of the chlorine radicals in step (a). In certain embodiments of the method that comprise step (di), i.e. electrolyzing the water vapour, the method further comprises directing the oxygen gas from step (di) to aid in combustion of a fuel to generate heat or power.

[0083] In certain embodiments of the method, the Sabatier reaction is catalysed by a catalyst selected from the group consisting of a nickel catalyst, a ruthenium catalyst, an alumina catalyst, and a copper catalyst. In certain embodiments, the catalyst is a copper catalyst.

[0084] In certain embodiments, the method further comprises compressing the methane (or the hydrocarbon fuel) to reduce the volume of the methane (or the hydrocarbon fuel). In certain embodiments, the method further comprises condensing the methane to produce liquefied natural gas. In certain embodiments, the method further comprises combusting the methane (or the hydrocarbon fuel) to generate heat or power. In certain embodiments, the method further comprises blending and co-firing the methane with a fuel (e.g. a fossil or hydrocarbon fuel, such as coal, gas, or any other fuel).

[0085] The present disclosure also relates to use of a Sabatier reaction for converting carbon dioxide gas into a hydrocarbon fuel in an industrial-size flue gas treatment system. In certain embodiments, but without limitation, the hydrocarbon fuel is methane. In certain embodiments, the hydrocarbon fuel is compressed to reduce its volume (e.g. to facilitate storage or transport). In certain embodiments, the hydrocarbon fuel is condensed to produce liquefied natural gas. In certain embodiments, the hydrocarbon fuel is blended and co-fired with coal.

[0086] The present disclosure also relates, without limitation, to the following enumerated embodiments:

[0087] Embodiment(s) 1: A system comprising: (a) a reactor configured to receive a gas stream comprising NO_x species and carbon dioxide gas, the reactor further configured to oxidize the NO_x species in the gas stream to produce hydrochloric acid; (b) an electrolytic unit configured to receive the hydrochloric acid and configured to electrolyse the hydrochloric acid to produce hydrogen gas; and (c) a carbon dioxide absorber configured to receive the gas stream from the reactor and the hydrogen gas from the electrolytic unit, the hydrogen gas for hydrogenating the carbon dioxide gas in the gas stream into a hydrocarbon fuel.

[0088] Embodiment(s) 2: The system according to embodiment(s) 1, wherein the reactor is a gas phase reactor.

[0089] Embodiment(s) 3: The system according to embodiment(s) 1 or 2, wherein the reactor is further configured to receive a chlorine gas stream.

[0090] Embodiment(s) 4: The system according to any one of embodiment(s) 1 to 3, further comprising a NO_x absorber.

[0091] Embodiment(s) 5: The system according to embodiment(s) 4, wherein the NO_x absorber is configured in series between the reactor and the carbon dioxide collector.

[0092] Embodiment(s) 6: The system according to any one of embodiment(s) 1 to 5, further comprising a SO_x absorber.

[0093] Embodiment(s) 7: The system according to any one of embodiment(s) 1 to 6, the gas stream further comprising water vapour, and the system further comprising a water vapour remover.

[0094] Embodiment(s) 8: The system according to embodiment(s) 7, wherein the water vapour remover is configured in series between the NO_x absorber and the carbon dioxide collector.

[0095] Embodiment(s) 9: The system according to embodiment(s) 8, wherein the water vapour remover is configured in parallel to the electrolytic unit.

[0096] Embodiment(s) 10: The system according to any one of embodiment(s) 1 to 9, wherein the carbon dioxide gas is converted to the hydrocarbon fuel by a Sabatier reaction.

[0097] Embodiment(s) 11: The system according to embodiment(s) 10, wherein the Sabatier reaction uses a catalyst selected from the group consisting of a nickel catalyst, a ruthenium catalyst, an alumina catalyst, and a copper catalyst.

[0098] Embodiment(s) 12: The system according to embodiment(s) 11, wherein the catalyst is the copper catalyst.

[0099] Embodiment(s) 13: A system comprising: (a) a gas phase reactor configured to receive a gas stream comprising NO_x species, water vapour, and carbon dioxide gas, the gas phase

reactor further configured to oxidize the NO_x species in the gas stream to produce hydrochloric acid; (b) a NO_x absorber configured to receive the gas stream from the gas phase reactor, the NO_x absorber further configured to oxidize the NO_x species in the gas stream, the NO_x absorber further configured to collect the hydrochloric acid produced from oxidizing the NO_x species in the gas stream in the NO_x absorber and oxidizing the NO_x species in the gas phase reactor; (c) an electrolytic unit configured to receive the hydrochloric acid collected at the NO_x absorber, and further configured to electrolyse the hydrochloric acid to produce hydrogen gas; (d) a water vapour remover configured to receive the gas stream from the NO_x absorber, and further configured to remove the water vapour from the gas stream; and (e) a carbon dioxide absorber configured to receive the gas stream from the water vapour remover and the hydrogen gas from the electrolytic unit, the hydrogen gas for hydrogenating the carbon dioxide gas in the gas stream into a hydrocarbon fuel.

[00100] Embodiment(s) 14: The system according to embodiment(s) 13, wherein the reactor is further configured to receive a chlorine gas stream.

[00101] Embodiment(s) 15: The system according to embodiment(s) 13 or 14, wherein the electrolytic unit is configured to electrolyse the hydrochloric acid to produce the hydrogen gas and chlorine gas.

[00102] Embodiment(s) 16: The system according to embodiment(s) 15, wherein the chlorine gas is recycled into the chlorine gas stream.

[00103] Embodiment(s) 17: The system according to any one of embodiment(s) 13 to 16, wherein the carbon dioxide gas is converted to the hydrocarbon fuel by a Sabatier reaction.

[00104] Embodiment(s) 18: The system according to embodiment(s) 17, wherein the Sabatier reaction uses a catalyst selected from the group consisting of a nickel catalyst, a ruthenium catalyst, an alumina catalyst, and a copper catalyst.

[00105] Embodiment(s) 19: A method of treating a gas stream comprising NO_x species, water vapour, and carbon dioxide gas, the method comprising: (a) generating hydroxyl radicals and chlorine radicals; (b) oxidizing the NO_x species in the gas stream with the hydroxyl radicals and chlorine radicals to produce nitric acid and hydrochloric acid; (c) removing the water vapour from the gas stream; (d) reacting the carbon dioxide gas with hydrogen gas produced

from electrolyzing the water vapour removed from the gas stream, the hydrochloric acid, or both, to produce a hydrocarbon fuel.

[00106] Embodiment(s) 20: The method according to embodiment(s) 19, the gas stream further comprising SO_x species, the method further comprising oxidizing the SO_x species.

[00107] Embodiment(s) 21: The method according to embodiment(s) 19 or 20, the gas stream further comprising a heavy metal, the method further comprising removing the heavy metal from the gas stream.

[00108] Embodiment(s) 22: The method according to embodiment(s) 21, wherein the heavy metal is mercury.

[00109] Embodiment(s) 23: The method according to any one of embodiment(s) 20 to 22, the gas stream further comprising trace elements selected from a group consisting of antimony, arsenic, cadmium, chromium, nickel, selenium, zirconium, and any combination thereof, the method further comprising removing the trace elements from the gas stream.

[00110] Embodiment(s) 24: The method according to embodiment(s) 23, further comprising capturing the trace elements in sulfuric acid produced from oxidizing the SO_x species, and removing the trace elements from the sulfuric acid by ion exchange.

[00111] Embodiment(s) 25: The method according to any one of embodiment(s) 19 to 24, further comprising electrolyzing the hydrochloric acid to produce chlorine gas.

[00112] Embodiment(s) 26: The method according to embodiment(s) 25, further comprising using the chlorine gas to generate at least some of the chlorine radicals.

[00113] Embodiment(s) 27: The method according to any one of embodiment(s) 19 to 26, further comprising electrolyzing the water vapour removed from the gas stream to produce oxygen gas.

[00114] Embodiment(s) 28: The method according to embodiment(s) 27, further comprising using the oxygen gas to aid in combustion.

[00115] Embodiment(s) 29: The method according to any one of embodiment(s) 19 to

28, wherein the carbon dioxide gas is converted into the hydrocarbon fuel by a Sabatier reaction.

[00116] Embodiment(s) 30: The method according to embodiment(s) 29, wherein the Sabatier reaction is catalysed by a catalyst selected from the group consisting of a nickel catalyst, a ruthenium catalyst, an alumina catalyst, and a copper catalyst.

[00117] Embodiment(s) 31: Use of a Sabatier reaction for converting carbon dioxide gas into a hydrocarbon fuel in an industrial-size flue gas treatment system.

[00118] Embodiment(s) 32: The use according to embodiment(s) 31, wherein the hydrocarbon fuel is methane.

[00119] The present invention will be further illustrated in the following non-limiting examples.

Example 1

[00120] Referring to Figure 1, and according to an embodiment of the present disclosure, there is a flue gas treatment system 100 configured for use within a coal-firing facility, the system 100 comprising a gas phase reactor 140, a SO_x absorber 150, a NO_x absorber 160, a water vapour remover 170, and a carbon dioxide absorber 180.

[00121] Flue gas 110 comprises SO_x species, NO_x species, water vapour, heavy metals (*e.g.* mercury), and carbon dioxide gas.

[00122] Chlorine gas 130 and flue gas 110 are: (i) delivered into the gas phase reactor 140 operating at pre-set reaction conditions; and (ii) mixed in the gas phase reactor 140. The gas phase reactor may be a reactor that is known in the art, such as a commercially available gas phase reactor. Appropriate reaction conditions are also known in the art (see for example U.S. Pat. No. 4,619,608). For example, the gas phase reactor 140 can be set at a temperature between about 100°C and about 650°C. For example, the temperature of the gas phase reactor 140 can be set at about 100°C, 125°C, 150°C, 175°C, 200°C, 225°C, 250°C, 275°C, 300°C, 325°C, 350°C, 375°C, 400°C, 425°C, 450°C, 475°C, 500°C, 525°C, 550°C, 575°C, 600°C, 625°C, 650°C, or any temperature therebetween.

[00123] At elevated temperatures in the gas phase reactor 140, it is believed that chlorine gas 130 reacts with the water vapour in the flue gas 110 to generate chlorine radicals and hydroxyl radicals. The NO_x species or a portion thereof present in the flue gas 110 is oxidized in the gas phase reactor 140 in the presence of the generated chlorine radicals and the generated hydroxyl radicals. Using nitric oxide (NO) as an example of a NO_x species, and without wishing to be bound by theory, it is believed that nitric oxide (NO) in flue gas 110 is oxidized to nitric acid (HNO₃) and hydrochloric acid in the gas phase reactor 140 according to the following chemical reactions:

6. $\text{NO} + \cdot\text{OH} \rightarrow \text{HNO}_2$;
7. $\text{NO} + \cdot\text{Cl} \rightarrow \text{NOCl}$;
8. $\text{NOCl} + \text{H}_2\text{O} \rightarrow \text{HNO}_2 + \text{HCl}$;
9. $\text{HNO}_2 + \cdot\text{Cl} \rightarrow \text{NO}_2 + \text{HCl}$;
10. $\text{NO}_2 + \cdot\text{OH} \rightarrow \text{HNO}_3$;
11. $\text{NO}_2 + \cdot\text{Cl} \rightarrow \text{NO}_2\text{Cl}$;
12. $\text{NO}_2\text{Cl} + \text{H}_2\text{O} \rightarrow \text{HNO}_3 + \text{HCl}$.

Without being bound by theory, it is also believed that the oxidized forms of polluting species are more readily removable from flue gas than the non-oxidized forms thereof. In addition, it is believed that the predominant final products of NO_x removal are nitric acid and hydrochloric acid. Gas stream 110a comprising dissolved nitric acid and hydrochloric acid and other pollutants exits the reactor 140 and is directed towards the SO_x absorber 150.

[00124] The SO_x absorber 150 may be any suitable absorber that is known in the art. For example, and as contemplated in this embodiment, the SO_x absorber 150 is one that is substantially similar to the one described in U.S. Pat. No. 4,619,608 both in design and reaction conditions. The SO_x absorber 150 may achieve SO₂ capture rates of above 99% without producing CO₂ as a by-product. Where CO₂ capture and storage by sequestration is desired, SO_x limits of 10 ppm or lower may be required. Conventional limestone scrubbers may not remove SO₂ from flue gas with the same efficiency.

[00125] The SO_x absorber 150 may be arranged horizontally or vertically, depending on spatial restrictions or requirements of the system 100. The SO_x absorber 150 may also comprise packed towers or cross-flow vessels that condense and collect resulting sulfuric acid, nitric acid, hydrochloric acid, or other acid streams, as well as heavy metal (e.g. mercury) products.

[00126] In the SO_x absorber 150, the gas stream 110a is sprayed with steam to facilitate SO_x oxidation; in the presence of the steam, SO_x generally reacts in preferential order over NO_x. Using sulfur dioxide (SO₂) as a non-limiting example of a SO_x species, and without wishing to be bound by theory, it is believed that the sulfur dioxide is oxidized to sulfuric acid (H₂SO₄) in the SO_x absorber 150 according to the following chemical reaction:



SO₂ removal rates of about 99% may be achieved at Cl₂ levels as low as 1.0 Cl₂/SO₂ molar ratio. An equilibrium concentration of about 70% or higher H₂SO₄ to H₂O may also be achieved. The collected mixture of H₂SO₄/H₂O may be further treated by a process 150' to remove H₂O therefrom, thereby concentrating the remaining sulfuric acid to a purity of up to about 93-96% (commercial grade). The purified H₂SO₄ may then be collected and shipped to industry for sale.

[00127] Although not shown in Figure 1, in certain embodiments the method may further comprise removing the heavy metals (or a portion thereof), e.g. mercury, in the SO_x absorber or in the gas stream exiting the SO_x absorber, e.g. by a process known in the art such as, but not limited to, the one described in PCT/CA1999/000403. For example, mercury may be converted into a mercury halide (e.g. mercury chloride) and collected from the sulfuric acid. In certain embodiments, heavy metal removal may or may further comprise capturing the trace elements (e.g. one or more of antimony, arsenic, cadmium, chromium, nickel, selenium, and zirconium) in the sulfuric acid produced from oxidizing the SO_x species, and removing the trace elements from the sulfuric acid by ion exchange. In other embodiments, heavy metal removal may not occur. Yet in other embodiments, heavy metal removal may occur at an off-site location.

[00128] After oxidation of the SO_x species in the SO_x absorber 150, gas stream 110b is produced and directed towards the NO_x absorber 160.

[00129] The NO_x absorber 160 may be any suitable NO_x absorber that is known in the art. For example, the NO_x absorber 160 may be one that is substantially similar to the one described in U.S. Pat. No. 4,619,608 both in design and reaction conditions. NO_x removal efficiency of about 98% may be achieved by the combination of a gas phase reactor and a NO_x absorber. Since no ammonia is used in the NO_x absorber 160, no ammonia slip occurs. The NO_x absorber 160 may be arranged horizontally or vertically, depending on spatial restrictions or requirements of the system 100. The NO_x absorber 160 may also comprise packed towers or cross-flow vessels that condense and collect nitric acid, hydrochloric acid, as well as heavy metal (e.g. mercury) products.

[00130] In the NO_x absorber 160, the gas stream 110b is sprayed with steam to further oxidize the NO_x species. The gas stream 110b may be sprayed with steam at a non-zero angle (e.g. orthogonally). The gas stream 110b may be sprayed with steam at a suitable spraying pressure. Without being bound by theory, it is believed that the following reactions are involved in the removal of NO_x species from gas stream 110b in the NO_x absorber 160:

14. $\text{Cl}_2 + \text{H}_2\text{O} \rightarrow \text{HOCl} + \text{HCl}$
15. $\text{NOCl} + \text{H}_2\text{O} \rightarrow \text{HNO}_2 + \text{HCl}$
16. $\text{NOCl} + \text{HOCl} + \text{H}_2\text{O} \rightarrow \text{HNO}_3 + 2\text{HCl}$
17. $\text{NO}_2\text{Cl} + \text{H}_2\text{O} \rightarrow \text{HNO}_2 + \text{HOCl}$
18. $2\text{NO}_2 + \text{H}_2\text{O} \rightarrow \text{HNO}_2 + \text{HNO}_3$
19. $\text{HNO}_2 + \text{HOCl} \rightarrow \text{HNO}_3 + \text{HCl}$
20. $2\text{NO} + \text{H}_2\text{O} + \text{HNO}_3 \rightarrow 3\text{HNO}_2$

It is believed that the predominant final products of NO_x removal are nitric acid and hydrochloric acid.

[00131] The NO_x absorber 160 collects nitric acid having a purity of up to about 99% that may be directed to further processing and/or storage 160'' in preparation for commercial shipment and/or sale.

[00132] The HCl produced from the oxidation of NO_x species in the gas reactor 140 and the NO_x absorber 160 is collected and directed to an electrolytic unit 160'. At the electrolytic unit 160', the HCl undergoes electrolysis to produce hydrogen gas and chlorine gas. Methods of electrolyzing hydrochloric acid are known in the art, and any commercially available electrolytic unit may be used. In a non-limiting example, the electrolytic unit comprises high temperature electrolysis cells.

[00133] The hydrogen gas produced from the electrolysis of HCl at electrolytic unit 160' may be re-used in the flue gas treatment system 100. In a non-limiting example, the produced hydrogen gas or a portion thereof is re-directed to the carbon dioxide absorber 180 for use in converting carbon dioxide gas into a hydrocarbon fuel.

[00134] The chlorine gas produced from the electrolysis of HCl at electrolytic unit 160' may be re-used in the flue gas treatment system 100. In a non-limiting example, the produced chlorine gas is re-directed towards the reactor 140 and forms the chlorine gas 130 or a part thereof.

[00135] Although not shown in Figure 1, in certain embodiments that gas stream 110b undergoes further heavy metal removal in the NO_x absorber 160 (*i.e.* removal of any heavy metals that were not removed in the SO_x absorber 150) by a process known in the art such as, but not limited to, the one described in PCT/CA1999/000403. For example, mercury may be converted into a mercury halide (*e.g.* mercury chloride) which may be collected, sold, or reused, for other downstream applications. In other embodiments, this further heavy metal removal process may not occur.

[00136] Gas stream 110c leaving the NO_x absorber 160 is generally removed of NO_x species and consists essentially of water vapour and carbon dioxide gas. Water vapour present in gas stream 110c is removed therefrom by the water vapour remover 170. Such removal may be done by methods known in the art. In a non-limiting example, thermal energy generated from the treatment system 100 (*e.g.* heat from excess steam, or heat generated specifically for the step of water vapour removal from gas stream 110c) is used to heat the gas stream 110c to evaporate the H₂O content remaining therein, the evaporated H₂O content being collectable downstream. In another non-limiting example, water vapour is removed from gas stream 110c by heat exchangers and the removed water vapour may be collected as

steam. Without such treatment or removal step, the water vapour generally would otherwise be vented into the atmosphere.

[00137] The collected evaporated H₂O content from gas stream 110c may be condensed into water, and the collected condensed water may be used for other purposes in the flue gas treatment system 100. Such other purposes include, but are not limited to: (i) returning the H₂O content recovered from gas stream 110c to a steam cycle of the flue gas treatment system 100; (ii) re-using the H₂O content recovered from gas stream 110c as process water in the SO_x absorber 150, the NO_x absorber 160, or both the SO_x absorber 150 and the NO_x absorber 160; (iii) using the H₂O content recovered from gas stream 110c to aid in the electrolysis 160' of HCl; and (iv) using the H₂O content recovered from gas stream 110c as a heat source to increase the temperature of the electrolytic reaction of HCl thereby improving the efficiency of said reaction at the electrolytic unit 160'. Such recycling of evaporated H₂O content from flue gas may be desired, particularly for flue gas treatment systems that are situated in locations that experience or are prone to drought or drought-like conditions. It is estimated that, for a 500 MW plant, up to about 750,000 lbs/hr of H₂O content that would otherwise be vented into the atmosphere as steam may be recovered and re-used within the treatment system 100.

[00138] Gas stream 110d, which is removed of water vapour, is directed to the carbon dioxide absorber 180 for further processing.

[00139] Gas stream 110d consists essentially of carbon dioxide gas. Hydrogen gas produced from the electrolysis of HCl at the electrolytic unit 160' is fed into the carbon dioxide absorber 180, and serves as a reactant required to hydrogenate the carbon dioxide gas in gas stream 110d into methane 112, at the carbon dioxide absorber 180, via the Sabatier process, at industrial scale and economically reasonable costs.

[00140] The Sabatier process is catalyzed in the carbon dioxide absorber 180 by an appropriate catalyst such as, but not limited to, a nickel catalyst, ruthenium, alumina, or a copper catalyst. As contemplated in this embodiment, the Sabatier process in the carbon dioxide collector 180 is catalyzed by a copper catalyst, and occurs under atmospheric pressure. As contemplated in this embodiment, the molar feed ratio of H₂:CO₂ is greater than or equal to about 3.5:1, and the Sabatier process is carried out at a temperature between

about 400°F and about 700°F. In other embodiments, other suitable reaction parameters may be used.

[00141] It is also contemplated in this embodiment (though not shown in Figure 1) that at least a portion of the water vapour removed from gas stream 110c and the H₂O content collected therefrom undergoes its own electrolytic reaction to generate hydrogen gas and oxygen gas. The hydrogen gas generated from the electrolysis of the collected H₂O content may be directed to the carbon dioxide absorber 180 for use in converting carbon dioxide gas into a hydrocarbon fuel and to further provide the volume of hydrogen gas that is required to hydrogenate the carbon dioxide gas in gas stream 110d into methane 112, at the carbon dioxide absorber 180, via the Sabatier process, at industrial scale and economically reasonable costs. The oxygen gas generated from said electrolysis may be used as a fuel source within the system 100. In other embodiments, the water vapour removed from gas stream 110c and the H₂O content collected therefrom does not undergo further hydrolysis.

[00142] Methane 112 produced in the carbon dioxide absorber 180 may be directed downstream for further processing 190. In certain embodiments, methane 112 (or a portion thereof) is compressed (condensed) by methods known in the art to form downstream fuel sources such as, but not limited to, liquefied natural gas (LNG), which may be used (or a portion thereof may be used) as a source of fuel in downstream applications, recycled for use as a fuel source within the system 100, or sold as a product (e.g. as a fuel or chemical feedstock). For example, but without limitation, LNG may be removed from the plant via cryogenic road tanker.

[00143] Since methane is combustible without requiring compression or other treatment, in certain embodiments (not shown in Figure 1) methane 112 (or a portion thereof) may be fed directly into the boiler of the plant, blended and co-fired with the coal, gas or another fossil or hydrocarbon fuel, or may be used as fuel to power a separate turbine, thereby eliminating or reducing the need to store, sequester, or sell the product of condensation (i.e. LNG), while increasing the power output of the plant.

[00144] In other non-limiting examples, the methane 112 (or a portion thereof) may be converted to other products such as, but not limited to, a methyl halide. In a non-limiting example, methane 212 (or a portion thereof) is converted to chloromethane through the

following reaction, as known in the art:

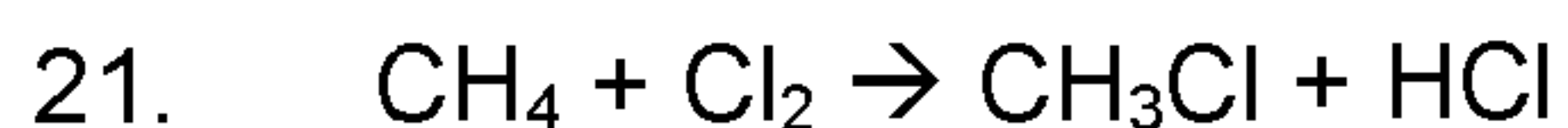

The resulting methyl chloride from Reaction 21 may be further processed into other organic polyhalides, such as dichloro-methane. The resulting methyl chloride may also be converted to other products like methyl alcohols, ethyl alcohols, ethers, aldehydes, ketones, organic acids, esters, amines, and fats and soaps.

Example 2

[00145] Referring to Figure 2, and according to another embodiment of the present disclosure, there is a flue gas treatment system 200 configured to serve a gas burning facility, the treatment system 200 comprising a gas phase reactor 140, a NO_x absorber 160, a water vapour remover 170, and a carbon dioxide absorber 180. As SO_x species are not generally produced in a gas burning facility, the presence of a SO_x absorber would be optional for a gas burning facility flue gas treatment system.

[00146] Flue gas 210 comprises NO_x species, water vapour, and carbon dioxide gas.

[00147] Chlorine gas 130 and flue gas 210 are: (i) delivered into the gas phase reactor 140 operating at pre-set reaction conditions such as the reaction conditions described in Example 1; and (ii) mixed in the gas phase reactor 140. For example, the gas phase reactor 140 can be set at a temperature between about 100°C and about 650°C. Flue gas 210 and chlorine gas 130 mix in the gas phase reactor 140, and the NO_x gas in the flue gas 210 is oxidized generally to nitric acid and hydrochloric acid (see for example Reactions 6 to 12). Gas stream 210a comprising dissolved nitric acid and hydrochloric acid and other pollutants exits the reactor 140 and is directed towards the NO_x absorber 160.

[00148] NO_x species that were not removed (e.g. converted) in the reactor 140 are removed from the gas stream 210a in the NO_x absorber 160. Without being bound by theory, it is believed that NO_x species that were not removed in the reactor 140 are removed from the gas stream 210a in the NO_x absorber 160 per reactions 14 to 20 described above in Example 1. It is believed that the predominant final products of NO_x removal are nitric acid and hydrochloric acid.

[00149] The NO_x absorber 160 collects nitric acid of a purity up to about 99% that may be directed to further processing and/or storage 160' in preparation for commercial shipment and/or sale.

[00150] Although not shown in Figure 2, in certain optional embodiments, gas stream 210a may undergo heavy metal removal in the NO_x absorber 160 by a process known in the art such as, but not limited to, the one described in PCT/CA1999/000403. In other embodiments, this heavy metal removal process may not occur. Heavy metals are generally not present in a gas plant.

[00151] The HCl produced from the oxidation of NO_x species in the gas reactor 140 and the NO_x absorber 160 is collected and directed to an electrolytic unit 160'. At the electrolytic unit 160', the HCl undergoes electrolysis to produce hydrogen gas and chlorine gas. Methods of electrolyzing hydrochloric acid are known in the art, and any commercially available electrolytic unit may be used. The hydrogen gas produced from the electrolysis of HCl at electrolytic unit 160' may be re-used in the flue gas treatment system 200. In a non-limiting example, the produced hydrogen gas or a portion thereof is re-directed to the carbon dioxide absorber 180 for use in converting carbon dioxide gas into a hydrocarbon fuel. The chlorine gas produced from the electrolysis of HCl at electrolytic unit 160' may be re-used in the flue gas treatment system 200. In a non-limiting example, the produced chlorine gas is re-directed towards the reactor 140 and forms the chlorine gas 130 or a part thereof.

[00152] Gas stream 210b leaving the NO_x absorber 160 is generally removed of NO_x species and consists essentially of water vapour and carbon dioxide gas. Water vapour present in gas stream 210b is removed therefrom by the water vapour remover 170. Such removal may be done by the non-limiting examples described in Example 1.

[00153] The collected evaporated H₂O content from gas stream 210b may be condensed into water, and the collected condensed water may be used for other purposes in the flue gas treatment system 200 such as, but not limited to, those described in Example 1. In addition, it is contemplated in this embodiment (though not shown in Figure 2) that at least a portion of the water vapour removed from gas stream 210b and the H₂O content collected therefrom undergoes its own electrolytic reaction to generate hydrogen gas and oxygen gas. The hydrogen gas generated from the electrolysis of the collected H₂O content may be directed

to the carbon dioxide absorber 180 for use in converting carbon dioxide gas into a hydrocarbon fuel. The oxygen gas generated from said electrolysis may be used as a fuel source within the system 200. In other embodiments, the water vapour removed from gas stream 210b and the H₂O content collected therefrom does not undergo further hydrolysis.

[00154] Gas stream 210c, which is removed of water vapour, is directed to the carbon dioxide absorber 180 for further processing. Gas stream 210c consists essentially of carbon dioxide gas. Hydrogen gas produced from the electrolysis of HCl at the electrolytic unit 160' is fed into the carbon dioxide absorber 180, and serves as a reactant that is required to hydrogenate the carbon dioxide gas in gas stream 210c into methane 212, at the carbon dioxide absorber 180, via the Sabatier process.

[00155] Methane 212 produced in the carbon dioxide absorber 180 may be directed downstream for further processing 290.

[00156] In certain embodiments, methane 112 (or a portion thereof) is condensed by methods known in the art to form downstream fuel sources such as, but not limited to, liquefied natural gas (LNG), which may be used (or a portion thereof may be used) as a source of fuel in downstream applications, recycled for use as a fuel source within the system 200, or sold as a product (e.g. as a fuel or chemical feedstock). For example, but without limitation, LNG may be removed from the plant via cryogenic road tanker.

[00157] Since methane is combustible without requiring further treatment, in certain embodiments (not shown in Figure 1) methane 112 or a portion thereof may be used as fuel to generate heat or power a turbine, thereby eliminating or reducing the need to store, sequester, or sell the product of condensation (i.e. LNG), while increasing the power output of the plant.

[00158] In addition to conversion to liquefied natural gas as described in Example 1, methane 212 (or a portion thereof) may be rendered into other products. In a non-limiting example, methane 212 (or a portion thereof) is converted to chloromethane using Reaction 21 (as described in Example 1). The resulting methyl chloride from Reaction 21 may be further processed into other organic polyhalides, such as dichloro-methane. The resulting methyl chloride may also be converted to other products like methyl alcohols, ethyl alcohols, ethers, aldehydes, ketones, organic acids, esters, amines, and fats and soaps.

[00159] While Examples 1 and 2 above describe the water vapour remover 170 and the carbon dioxide absorber 180 as separate units, in other embodiments and examples, the water vapour remover and the carbon dioxide absorber may be combined as one unit. In a non-limiting example, heat exchangers are placed around the carbon dioxide absorber to evaporate the water vapour from the gas stream prior to reacting the carbon dioxide gas remaining in the gas stream with hydrogen gas. In another non-limiting example, steam from the system is passed over the carbon dioxide absorber to evaporate the water vapour from the gas stream prior to reacting the carbon dioxide gas remaining in the gas stream with hydrogen gas.

[00160] It is understood that the embodiments presented in the disclosure are non-limiting examples of flue gas treatment systems contemplated in this disclosure. While in the embodiments only one clean-up unit (e.g. a SO_x absorber, a NO_x absorber, a carbon dioxide absorber, a Sabatier reactor, etc.) is described for each targeted flue gas pollutant, other embodiments may contemplate one or more clean-up units per targeted flue gas pollutant. For example, a treatment system may comprise one or more gas phase reactors connected in series, one or more SO_x absorbers connected in series, one or more NO_x absorbers connected in series, one or more water vapour removers connected in series, one or more H₂O electrolytic units connected in series, one or more HCl electrolytic units connected in series, and/or one or more carbon dioxide absorbers connected in series. Having one or more of the same clean-up units arranged in series may improve the collection and removal of certain flue gas pollutants. For example, since the volumes of carbon dioxide in the flue gas are much greater than the volumes of SO_x and NO_x species in the flue gas, additional carbon dioxide absorbers connected in series may be beneficial in order to adequately remove the carbon dioxide from the flue gas by converting it, for example by the Sabatier process, into, for example, a hydrocarbon fuel for use in downstream applications.

[00161] All citations herein, and all documents cited in the cited documents, are hereby incorporated by reference.

[00162] It is contemplated that any part of any aspect or embodiment discussed in this specification can be implemented or combined with any part of any other aspect or embodiment discussed in this specification. While particular embodiments have been described in the foregoing, it is to be understood that other embodiments are possible and are intended to be included herein. It will be clear to any person skilled in the art that modification

of and adjustment to the foregoing embodiments, not shown, is possible. Accordingly, the scope of the claims should not be limited by the preferred embodiments set forth in the examples, but should be given the broadest interpretation consistent with the description as a whole.

REFERENCES:

-
- [1] Patel, S., The Big Picture: Energy for Power, *Power*, April 2016, p. 12.
- [2] Patel, S., The Big Picture: Future Coal Fleet, *Power*, January 2016, p. 10.
- [3] Environmental Defense Fund, Coal-fired Power Plants are Big Contributors to Sooty Particle Pollution in Eastern States, 2008.
- [4] Bemand, P.P. *et al.*, *J. Chem. Soc. Faraday Trans. 1*, 1973, 69: 1356.
- [5] Water Vapor, NOAA National Centers for Environmental Information, <https://www.ncdc.noaa.gov/monitoring-references/faq/greenhouse-gases.php>, accessed December 14, 2016.
- [6] Ralston, J., The Sabatier Reaction, Possible Sources of CO₂ Emissions, March 4, 2010, <http://www.pennenergy.com/articles/pennenergy/2010/03/the-sabatier-reaction.html>, accessed December 14, 2016.
- [7] Lunde, P.J *et al.*, *Ind. Eng. Chem. Process Des. Dev.*, 1974, 13(1): 27-33.

WHAT IS CLAIMED IS:

1. A system comprising:
 - (a) a gas phase oxidation (GPO) reactor configured to receive a flue gas stream comprising NO_x species and carbon dioxide gas, the GPO reactor further configured to receive chlorine gas, liquid or solution, and to oxidize the NO_x species in the flue gas stream to produce a gas stream comprising nitric acid and hydrochloric acid;
 - (b) an electrolytic unit configured to receive the hydrochloric acid and configured to electrolyse the hydrochloric acid to produce hydrogen gas and chlorine gas; and
 - (c) a Sabatier reactor configured to receive both a gas stream, downstream from the GPO reactor, and at least a portion of the hydrogen gas from the electrolytic unit, the Sabatier reactor further configured to hydrogenate the carbon dioxide gas in the gas stream into a hydrocarbon fuel comprising methane.
2. The system according to claim 1, wherein the GPO reactor is configured to receive a chlorine gas stream.
3. The system according to claim 1 or 2, further comprising a NO_x absorber configured to receive a gas stream from (a) or downstream from (a), the NO_x absorber further configured to oxidize and collect the NO_x species remaining in the gas stream as hydrochloric acid, wherein the system is further configured to direct at least a portion of the hydrochloric acid from the NO_x absorber to the electrolytic unit.
4. The system according to claim 3, wherein the NO_x absorber is configured in series between the GPO reactor and the Sabatier reactor.
5. The system according to claim 1 or 2, wherein the flue gas further comprises SO_x species, and wherein the system further comprises a SO_x absorber configured to receive a gas stream from (a) or downstream from (a), and further configured to oxidize and collect the SO_x species in the gas stream as sulfuric acid.
6. The system according to claim 3 or 4, wherein the flue gas further comprises SO_x

- species, and wherein the system further comprises a SO_x absorber configured in series between the GPO reactor and the NO_x absorber, the SO_x absorber configured to receive a gas stream from (a) or downstream from (a), and further configured to oxidize and collect the SO_x species in the gas stream as sulfuric acid.
7. The system according to claim 5 or 6, wherein the flue gas further comprises mercury and/or at least one heavy metal trace element, and wherein the SO_x absorber is further configured to remove the mercury and/or the at least one heavy metal trace element.
 8. The system according to any one of claims 1 to 7, wherein the flue gas further comprises water vapour, and wherein the system further comprises a water vapour remover configured to remove the water vapour from the gas stream before (c).
 9. The system according to claim 3, 4 or 6, wherein the flue gas further comprises water vapour, and wherein the system further comprises a water vapour remover configured in series between the NO_x absorber and the Sabatier reactor.
 10. The system according to claim 8 or 9, wherein the water vapour remover is configured in parallel to the electrolytic unit.
 11. The system according to any one of claims 1 to 10, wherein the Sabatier reactor uses a catalyst selected from the group consisting of a nickel catalyst, a ruthenium catalyst, an alumina catalyst, and a copper catalyst.
 12. The system according to claim 11, wherein the catalyst is the copper catalyst.
 13. The system according to any one of claims 1 to 12, further configured to direct the methane to a boiler or combustion chamber for combustion of the methane to generate heat or power.
 14. The system according to any one of claims 1 to 12, further comprising a compressor configured to condense liquefied natural gas from the methane.
 15. The system according to any one of claims 1 to 14, wherein at least a portion of the chlorine gas produced in the electrolytic unit is recycled into the GPO reactor.
 16. A method of producing a hydrocarbon fuel, comprising methane, from a flue gas stream

- comprising NO_x species, water vapour, and carbon dioxide gas, the method comprising:
- (a) generating hydroxyl radicals and chlorine radicals;
 - (b) oxidizing the NO_x species in the gas stream with the hydroxyl radicals and chlorine radicals to produce a gas stream comprising nitric acid and hydrochloric acid, water vapour and carbon dioxide gas;
 - (c) removing the water vapour from the gas stream to produce a dehydrated gas stream;
 - (d) producing hydrogen gas from electrolyzing the hydrochloric acid produced in (b), and optionally from electrolyzing the water vapour removed from the gas stream in (c);
 - (e) using a Sabatier reaction to hydrogenate the carbon dioxide gas in the dehydrated gas stream from (c) with the hydrogen gas produced in (d) to produce the hydrocarbon fuel.
17. The method according to claim 16, wherein the flue gas stream further comprises SO_x species, and wherein the method further comprises:
- (bi) oxidizing the SO_x species to produce sulfuric acid, and removing the sulfuric acid from the gas stream to produce a gas stream that is substantially free of SO_x species.
18. The method according to claim 17, wherein the flue gas stream further comprises trace elements selected from a group consisting of antimony, arsenic, cadmium, chromium, nickel, selenium, zirconium, and any combination thereof, and wherein the method further comprises removing the trace elements from the gas stream by capturing the trace elements in the sulfuric acid.
19. The method according to claim 18, further comprising removing the trace elements from the sulfuric acid by ion exchange.
20. The method according to any one of claims 17 to 19, the flue gas stream further comprising mercury, and wherein the method further comprises removing the mercury

from the gas stream.

21. The method according to claim 20, wherein removing the mercury comprises converting the mercury to HgCl_2 and capturing the HgCl_2 in the sulfuric acid.
22. The method according to claim 21, further comprising recovering the mercury from the sulfuric acid.
23. The method according to any one of claims 16 to 22, further comprising:
 - (bii) further oxidizing the NO_x species with steam to produce hydrochloric acid and a gas stream that is substantially free of NO_x species.
24. The method according to claim 23, further comprising using chlorine gas produced from (d) to generate at least some of the chlorine radicals in (a).
25. The method according to any one of claims 16 to 24, wherein (d) comprises electrolyzing the water vapour removed from the gas stream in (c), the electrolyzing of the water vapour also producing oxygen gas.
26. The method according to claim 25, further comprising directing the oxygen gas from (d) to aid in combustion of a fuel to generate heat or power.
27. The method according to any one of claims 16 to 26, wherein the Sabatier reaction is catalysed by a catalyst selected from the group consisting of a nickel catalyst, a ruthenium catalyst, an alumina catalyst, and a copper catalyst.
28. The method according to any one of claims 16 to 27, further comprising compressing the methane to reduce the volume of the methane.
29. The method according to any one of claims 16 to 28, further comprising combusting the methane to generate heat or power.
30. The method according to claim 28 or 29, wherein the methane is blended and co-fired with another hydrocarbon fuel, optionally selected from coal or gas.
31. The method according to any one of claims 16 to 27, further comprising condensing the

methane to produce liquefied natural gas.

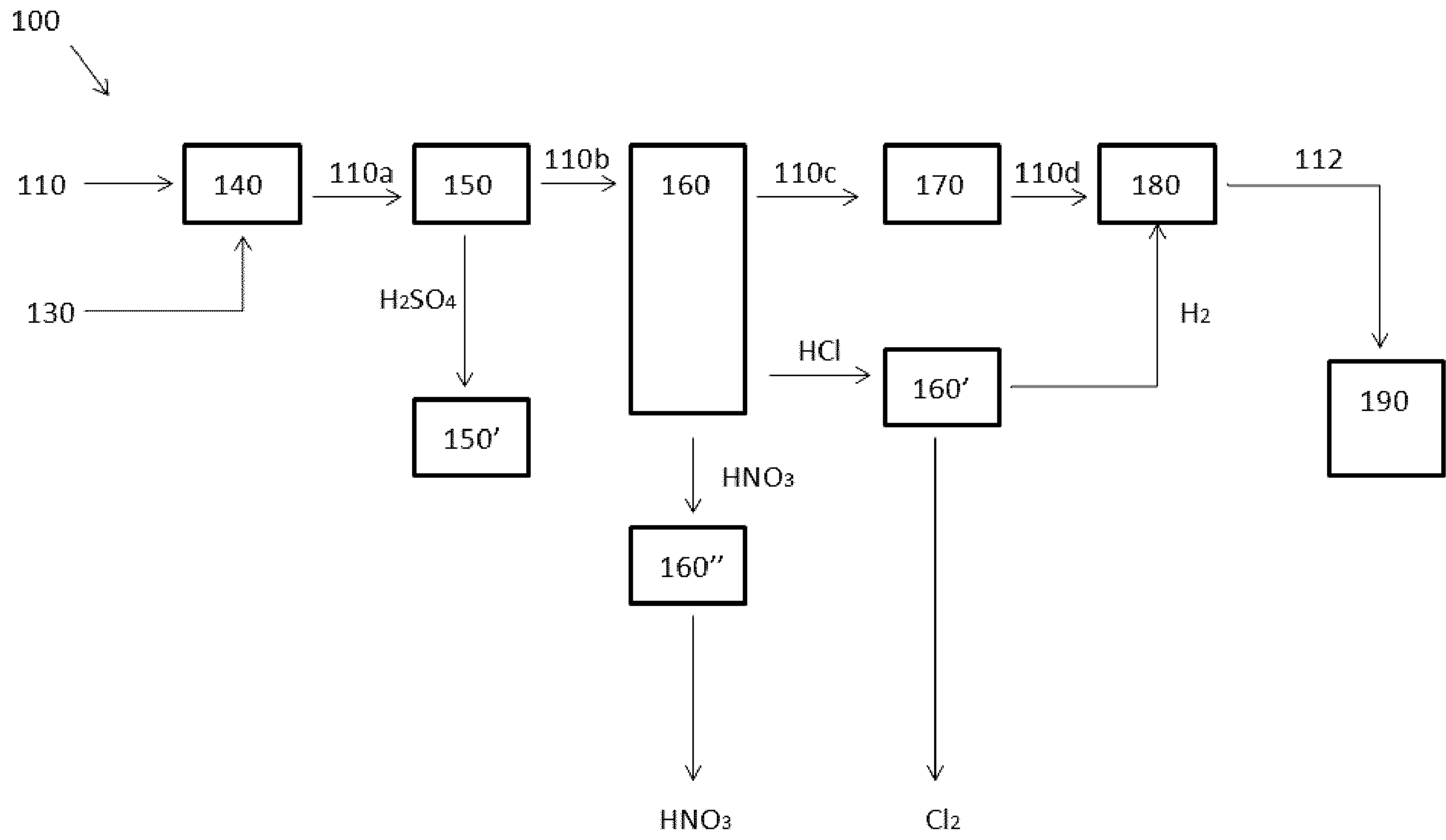

FIGURE 1

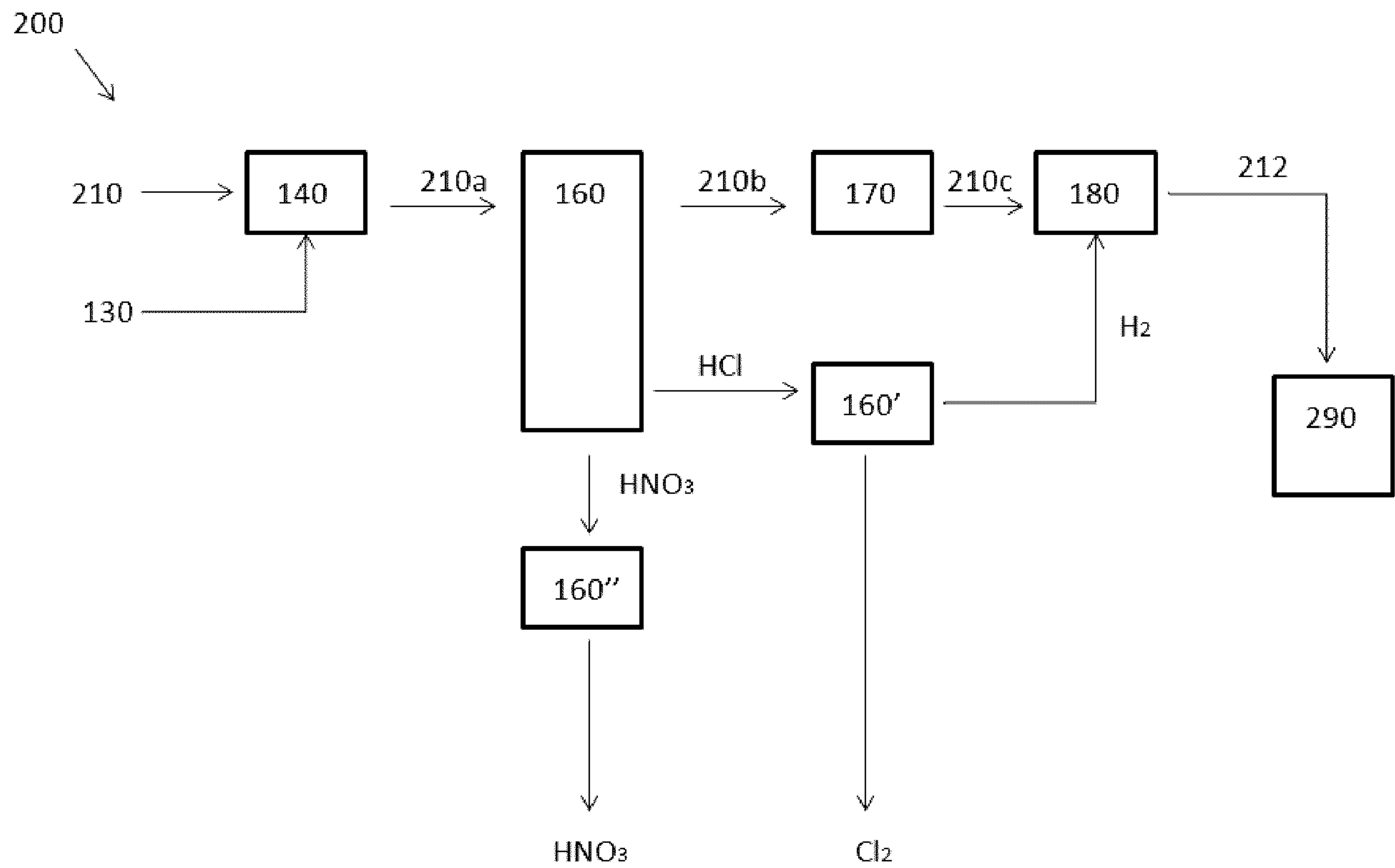

FIGURE 2

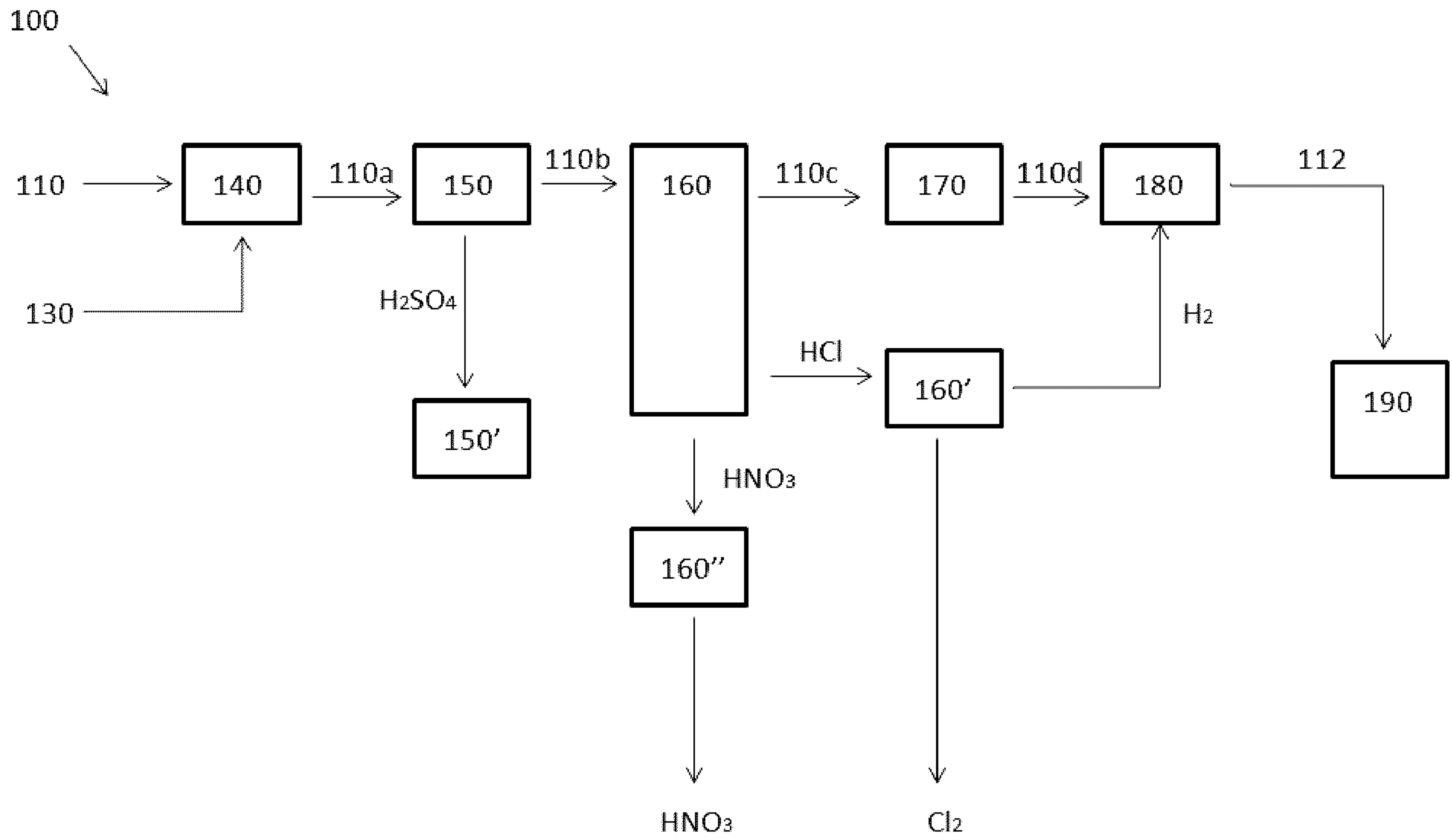

FIGURE 1