

(21) Application No: 0904362.1
(22) Date of Filing: 13.03.2009
(30) Priority Data:
(31) 61036701 (32) 14.03.2008 (33) US

(51) INT CL:
A47L 9/00 (2006.01)
(56) Documents Cited:
GB 2447355 A US 20080086831 A1
(58) Field of Search:
INT CL A47L
Other: ONLINE: WPI EPODOC

(71) Applicant(s):
Bissell Homecare, Inc.
(Incorporated in USA - Michigan)
2345 Walker N W, Grand Rapids,
MI 49544-2516, United States of America

(72) Inventor(s):
Joseph A Fester
James Minnema Jr
Gary A Kasper

(74) Agent and/or Address for Service:
Sanderson & Co
34 East Stockwell Street, COLCHESTER,
Essex, CO1 1ST, United Kingdom

(54) Abstract Title: Vacuum cleaner

(57) A vacuum cleaner has a hair collection assembly 308 moveable to, and latchable 400 in, a position in which it is in contact with a surface to be cleaned. Also disclosed is a vacuum cleaner with a cyclone, with an internal grill with apertures (120,fig.3) with leading edges at an acute angle to the air flow. Also disclosed is a vacuum cleaner with a dirt cut 160 latched to a cyclone 58.

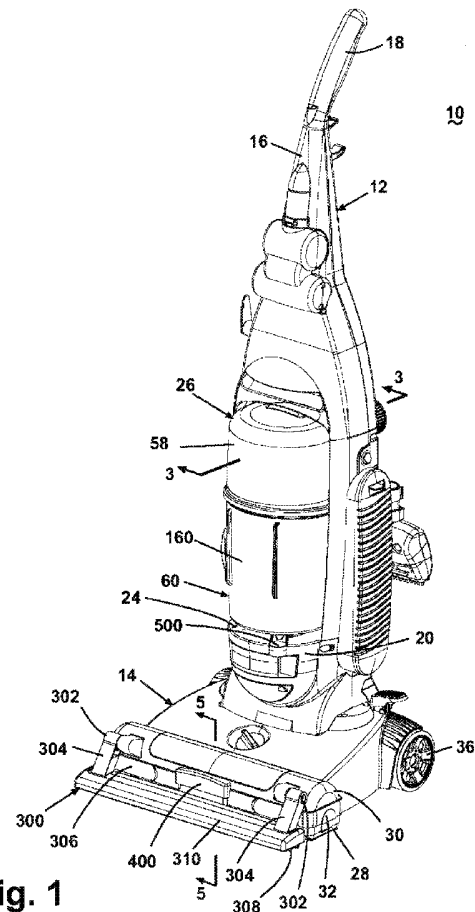

Fig. 1

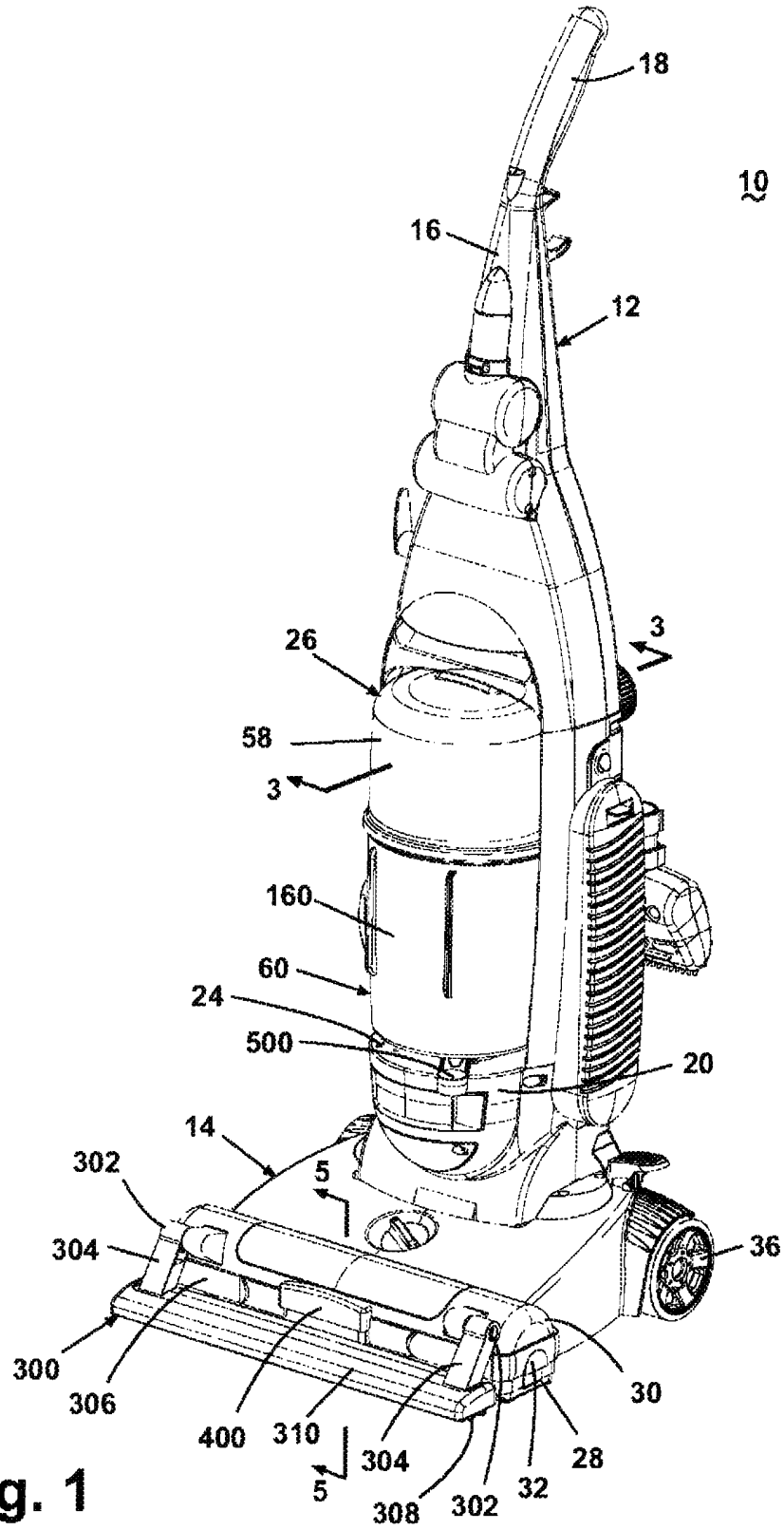

Fig. 1

1110

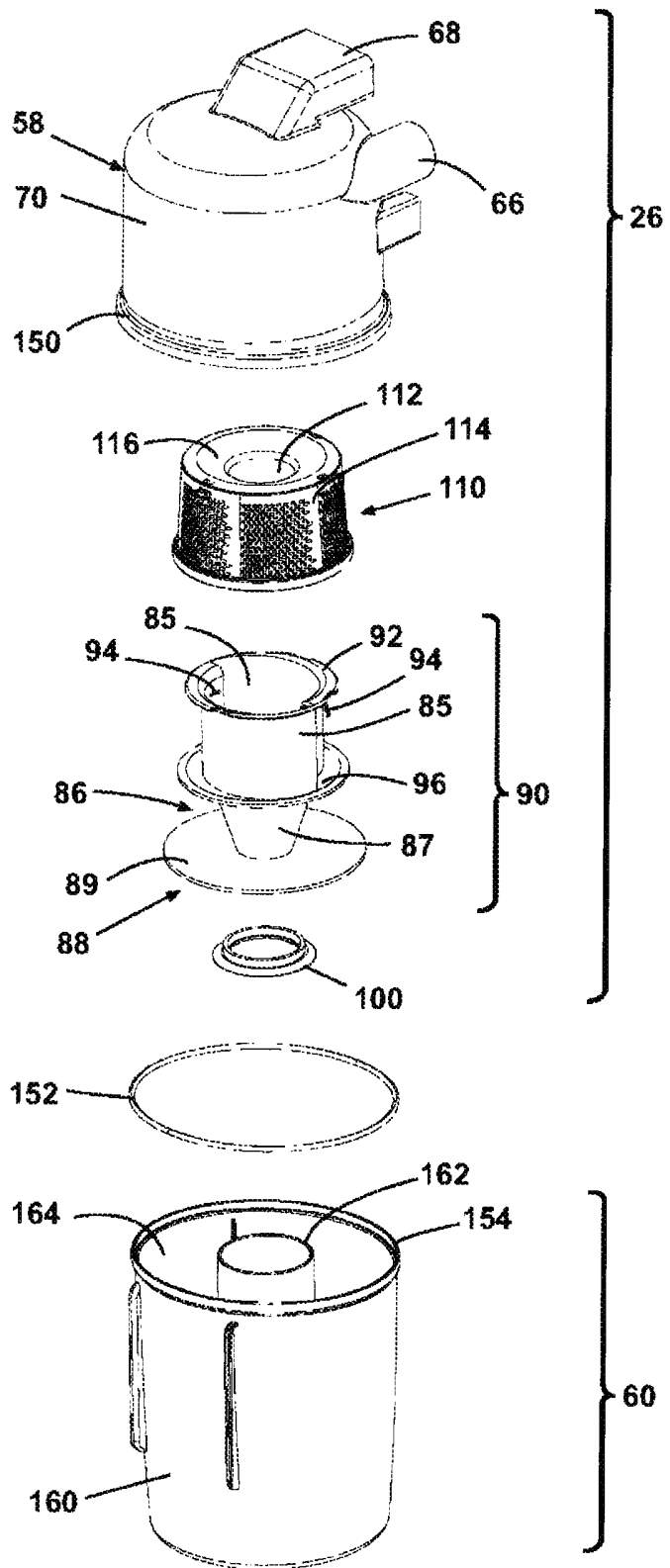

Fig. 2

2/10

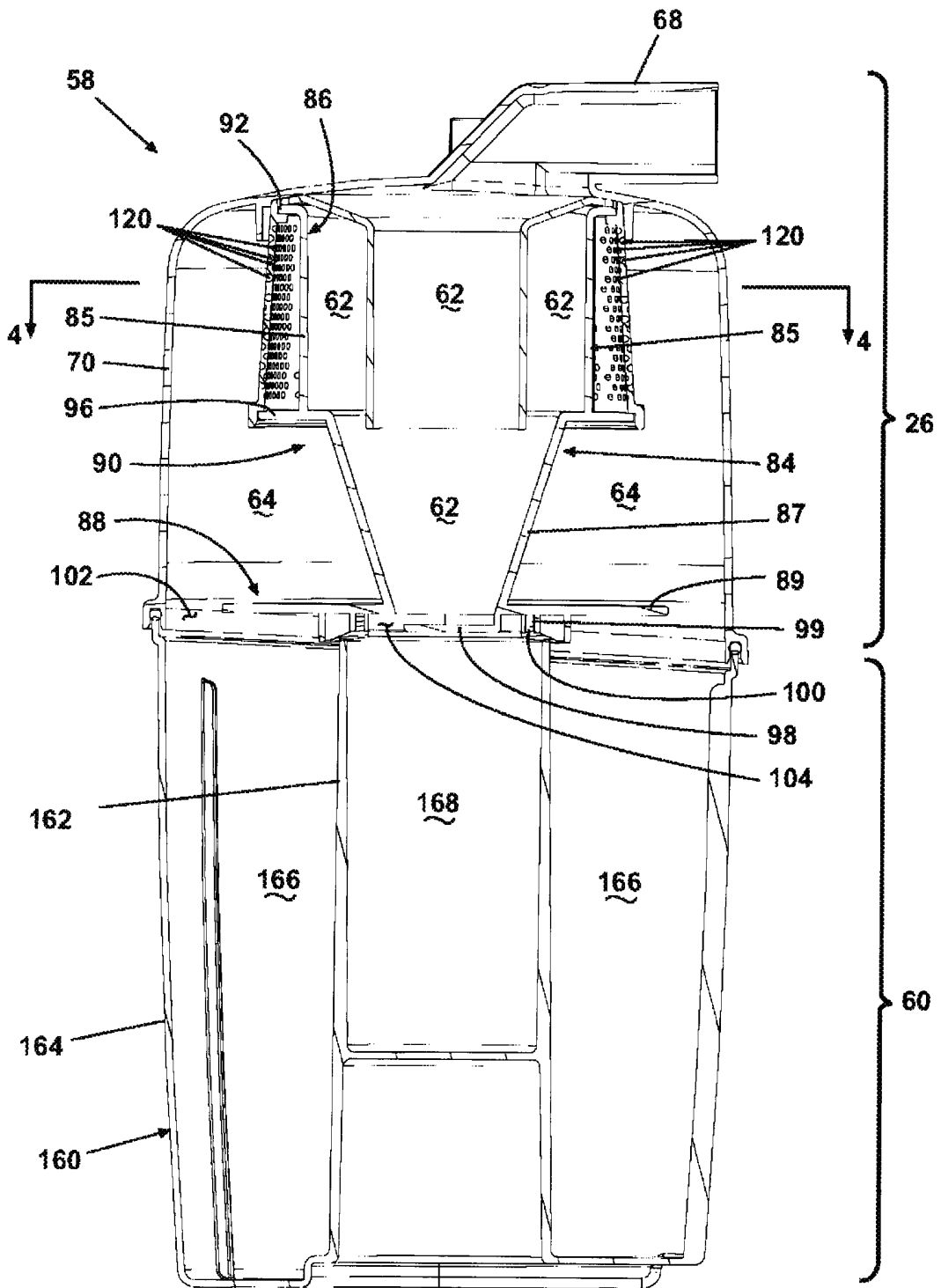

Fig. 3

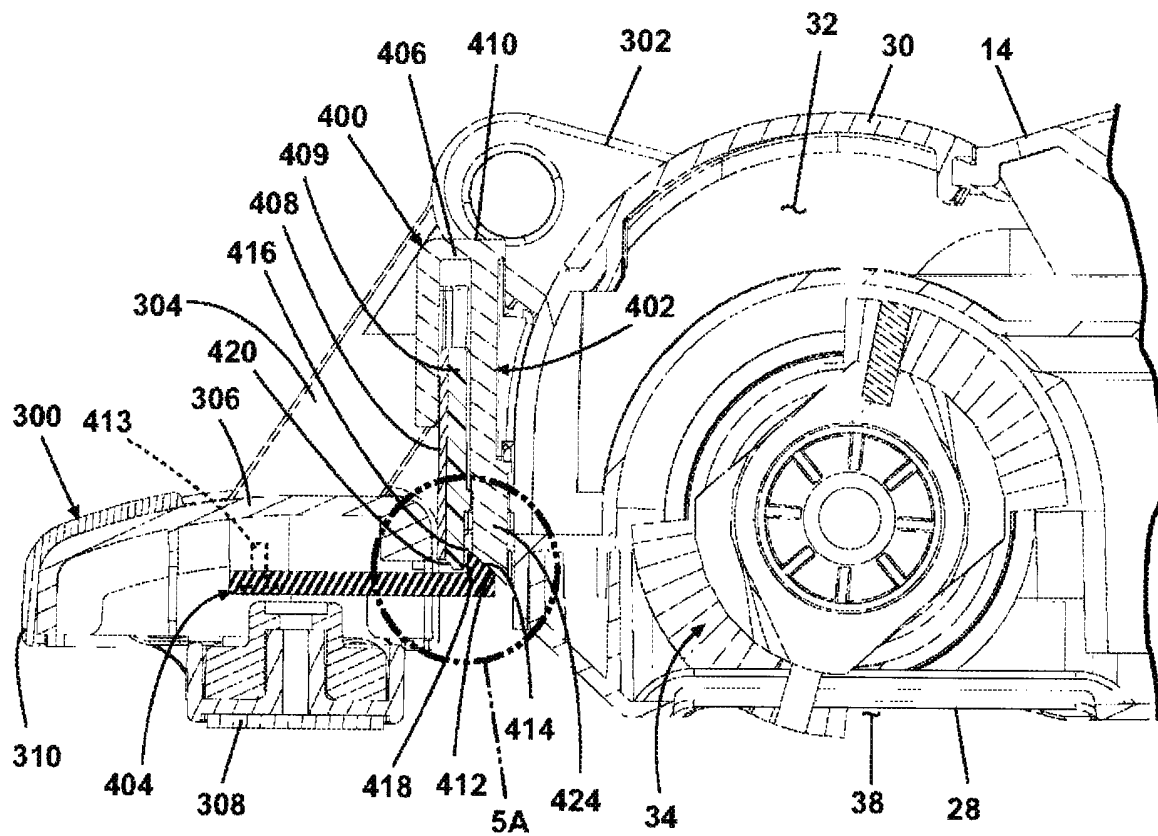

Fig. 5

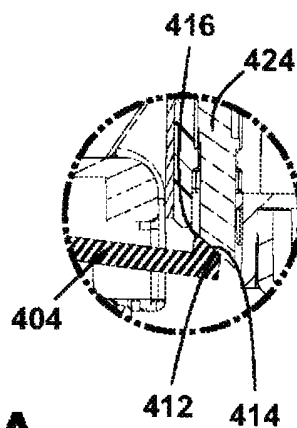

Fig. 5A

5/10

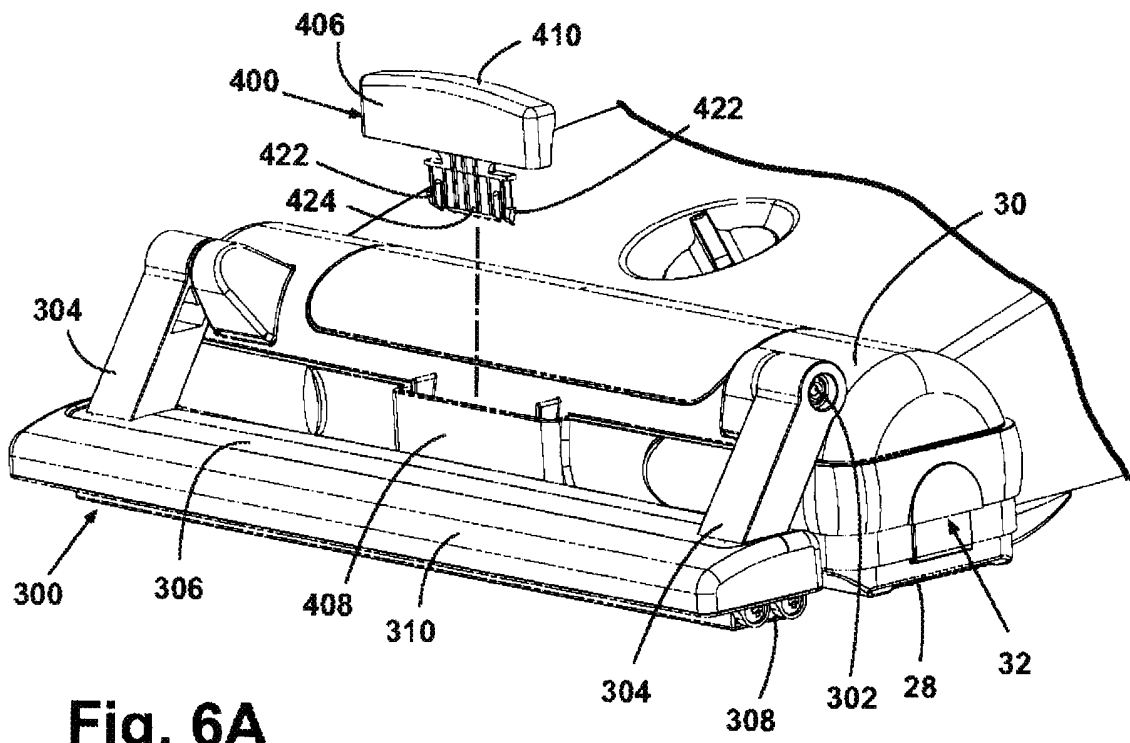

Fig. 6A

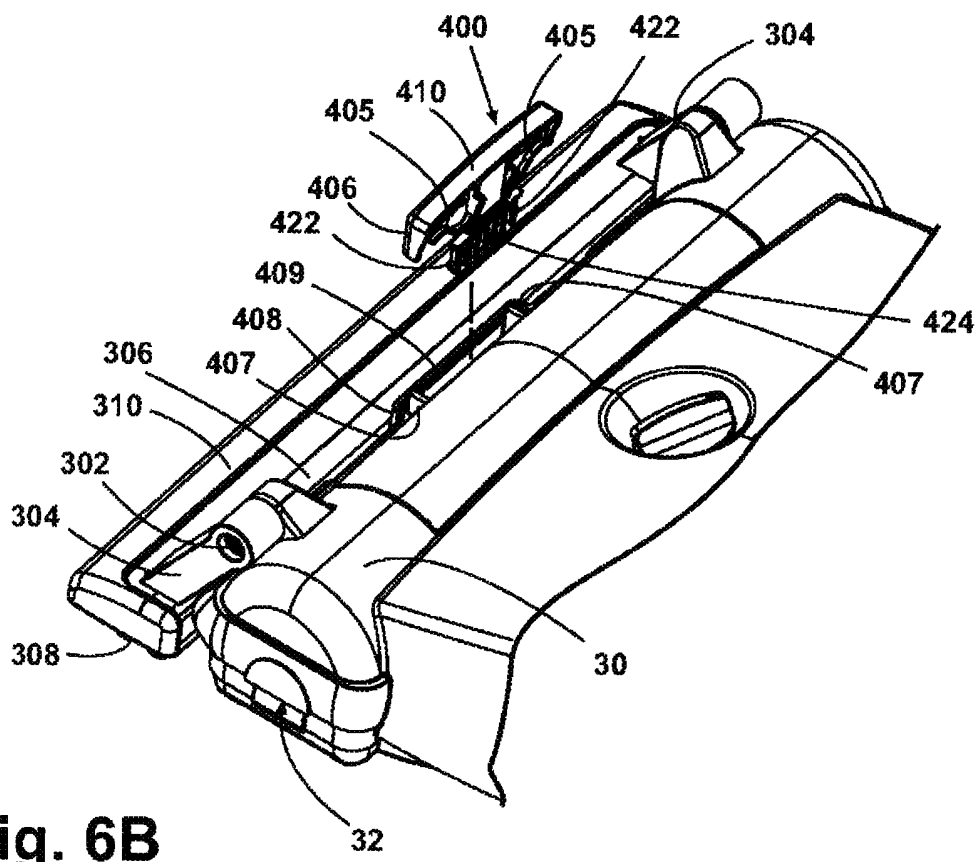

Fig. 6B

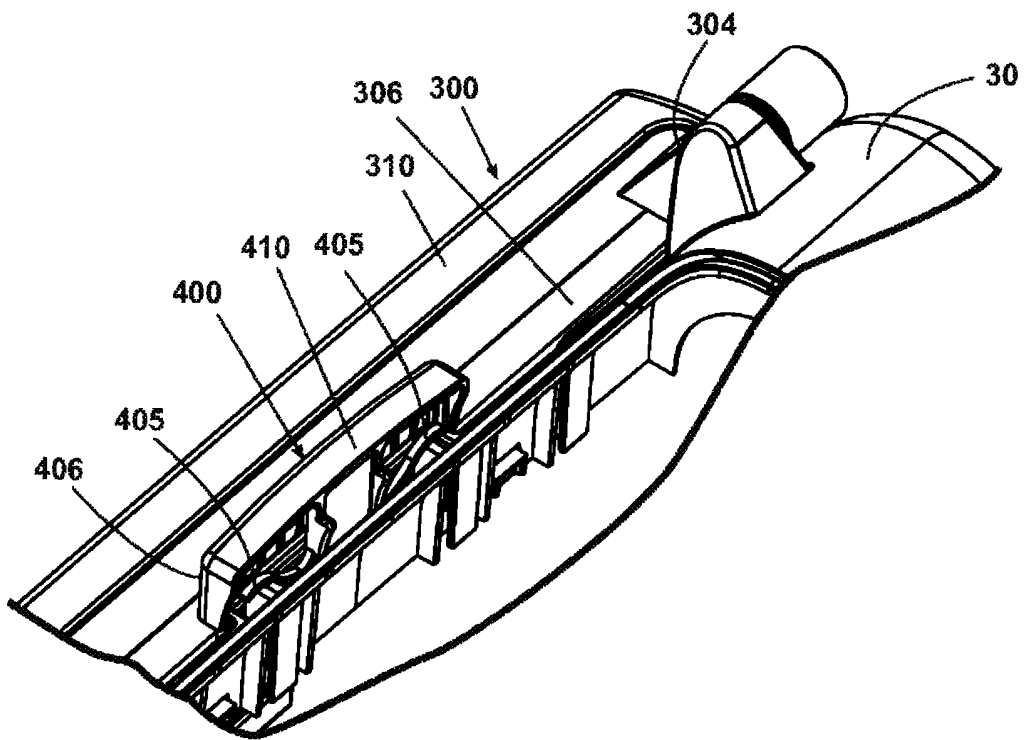

Fig. 6C

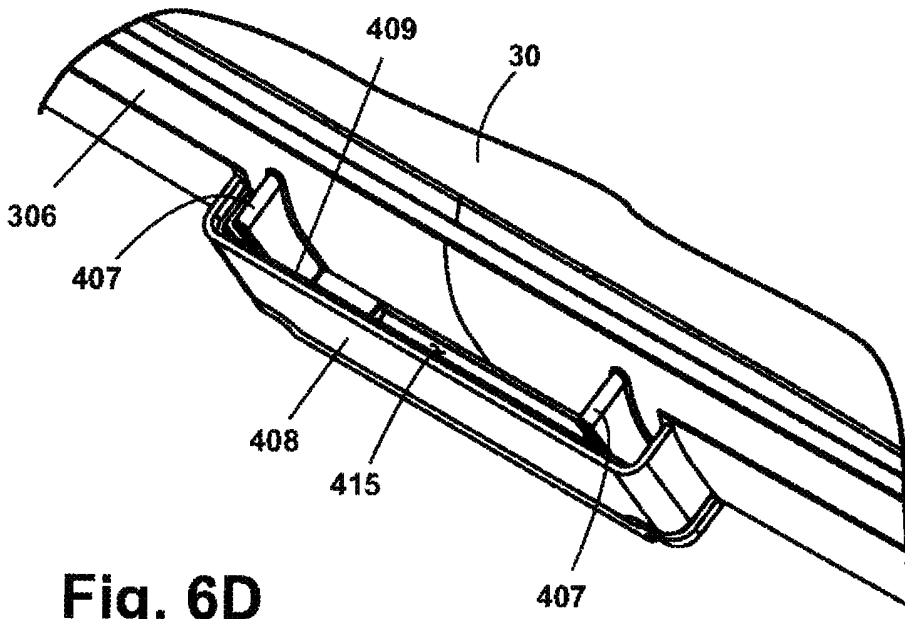

Fig. 6D

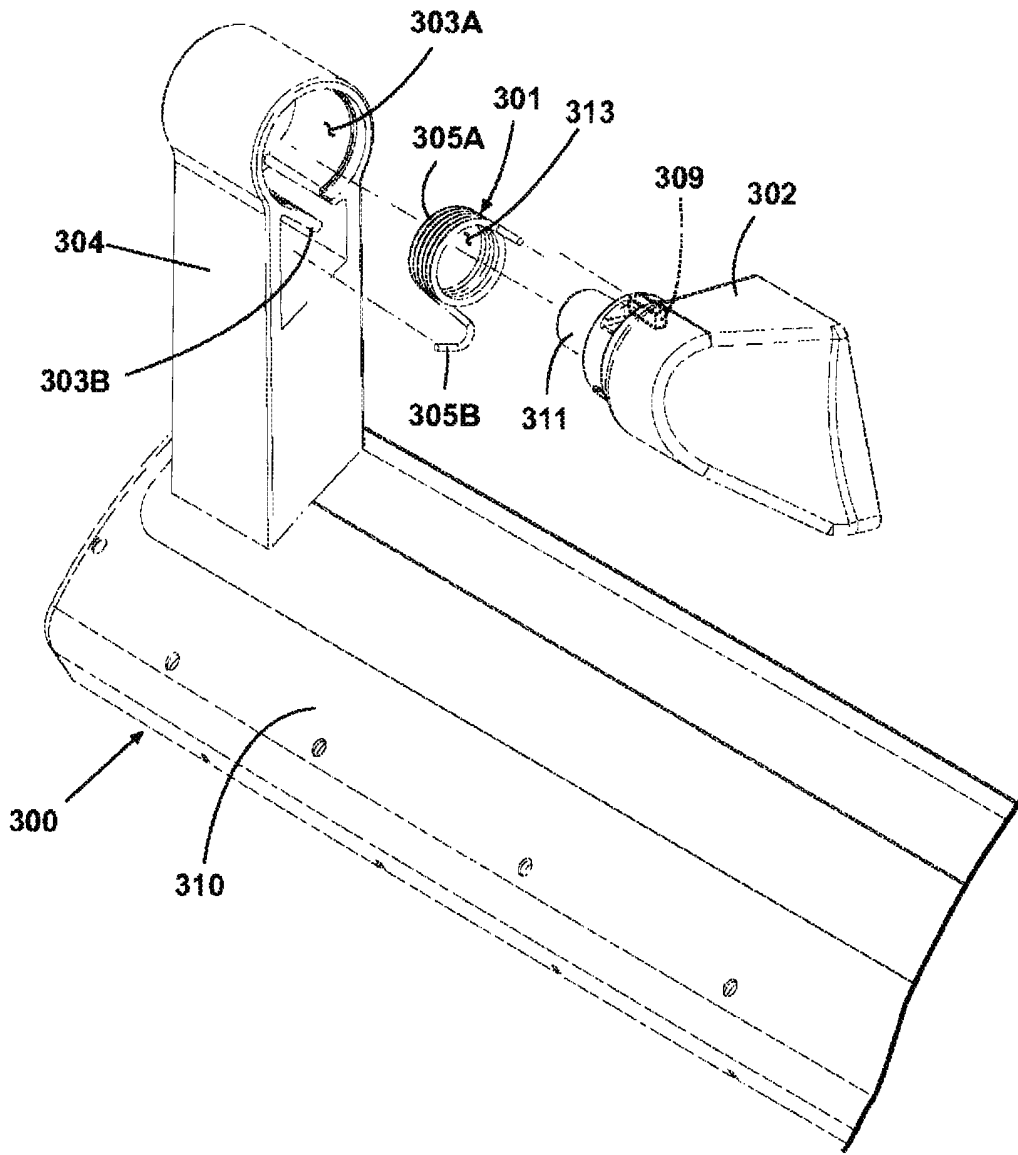

Fig. 7

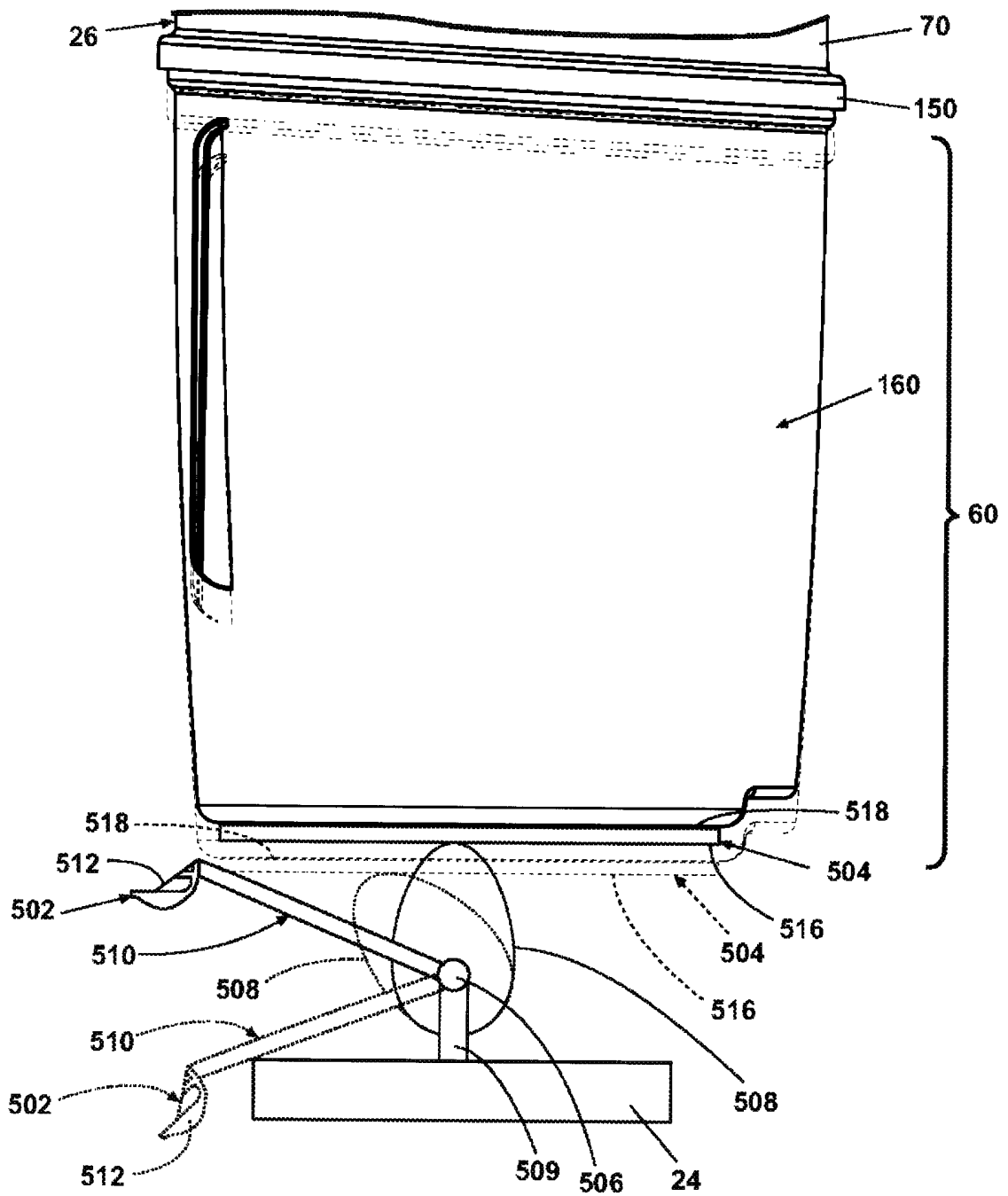

Fig. 8

9/10

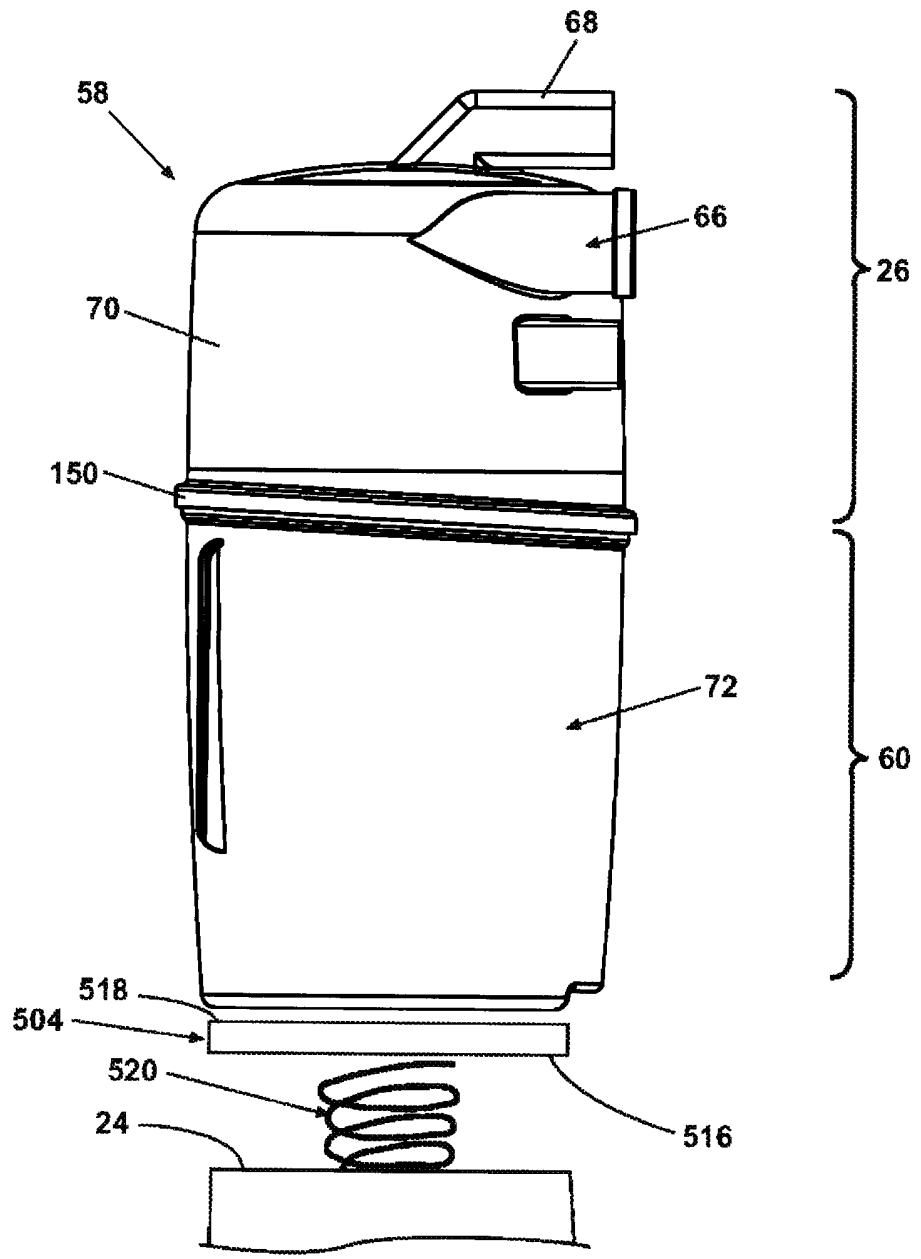

Fig. 9

10/10

**VACUUM CLEANER WITH CYCLONIC DIRT SEPARATION
AND PET HAIR REMOVER**

BACKGROUND OF THE INVENTION

Field of the Invention

The invention relates to suction cleaners. In one of its aspects, the invention relates to a suction cleaner having cyclonic dirt separation. In another of its aspects, the invention relates to a cyclone separator with an improved exhaust grill. In another of its aspects, the invention relates to a vacuum cleaner with a moveable pet hair removal device that is selectively retained in contact with a surface to be cleaned. In still another of its aspects, the invention relates to a dirt cup latching mechanism.

Description of the Related Art

Upright vacuum cleaners employing cyclone separators are well known. Many conventional cyclone separators use frusto-conical shape separators or high-speed rotational motion of the air/dirt to separate the dirt by centrifugal force. Typically, working air enters and exits at an upper portion of the cyclone separator while the bottom portion of the cyclone separator is used to collect debris. In an effort to reduce weight, the motor/fan assembly that creates the working air flow is typically placed at the bottom of the handle, below the cyclone separator.

BISSELL Homecare, Inc. presently manufactures and sells in the United States an upright vacuum cleaner that has a cyclone separator and a dirt cup. A horizontal plate separates the cyclone separator from the dirt cup. The air flowing through the cyclone separator passes through an annular cylindrical cage with baffles and through a cylindrical filter before exiting the cyclone separator at the upper end thereof. The dirt cup and the cyclone separator are disclosed in more detail in U.S. Patent No. 6,810,557, which is incorporated herein by reference in its entirety.

U.S. Patent No. 4,571,772 to Dyson discloses an upright vacuum cleaner employing a two stage cyclone separator. The first stage is a single separator having an outlet in series with an inlet to a second stage frusto-conical separator.

U.S. Patent Application Publication No. 2006/0130441 to Oh discloses an
5 exhaust grill for a cyclone separator. Air passages in the grill have a leading surface facing toward the direction of air flow around the grill. It is taught that the direct flow of air into the grill prevents stagnant vortices from forming in the grill air passages, thus preventing debris build-up.

U.S. Patent Application Publication No. 2007/0143954 to Graham discloses a
10 hair collection assembly mounted to the cleaning head of a vacuum cleaner for movement between a use position in which the hair collection element is in contact with the surface to be cleaned and a second position in which the hair collection element is spaced from the surface.

SUMMARY OF THE INVENTION

15 A vacuum cleaner according to the invention comprises a cleaning head assembly having a suction nozzle adapted to be moved along a surface to be cleaned, a hair collection assembly having a hair collection element adapted to collect hair from the surface to be cleaned, wherein the hair collection assembly is mounted to the cleaning head for movement of the hair collection element between a first position in
20 which the hair collection element is in contact with the surface to be cleaned, and a second position, in which the hair collection element is spaced from the surface to be cleaned, and a latch assembly to selective retain the hair collection assembly on the surface to be cleaned.

In one embodiment, the latch assembly further comprises a latch portion as a part of one of the cleaning head assembly and the hair collection assembly and a catch portion as a part of the other of the cleaning head assembly and the hair collection assembly.

5 In another embodiment, the catch portion is made of a resilient material. The latch portion can include a disengaging member that is adapted to selectively deform the catch portion to release the latch assembly when the disengaging member is actuated by a user.

In another embodiment, a spring biasing member biases the hair collection
10 assembly to the second position to move the hair collection assembly from the first position to the second position when the catch portion is released from the latch portion.

In another embodiment, a vacuum cleaner according to the invention comprises an exhaust grill in the cyclone separation chamber to filter out larger debris, the exhaust grill comprising a plurality of apertures whereby a leading edge of the aperture forms an
15 acute angle relative to the flow of working air.

Further according to the invention, a vacuum cleaner comprises a cleaning head assembly having a suction nozzle, a housing coupled to the cleaning head assembly, a suction source mounted in the housing for creating a flow of working air and a cyclone module assembly mounted in the housing in fluid communication with the suction
20 nozzle and the suction source. The cyclone module assembly comprises a cyclone separation chamber for separating dust and debris from air, the cyclone separation chamber having an inlet opening in fluid communication with the suction nozzle through the working air path, an outlet opening for discharging cleaned air and a particle discharge outlet for discharging dust and debris separated from air and a dirt

cup removably mounted to the cyclone separation chamber in fluid communication with the particle discharge outlet for collecting dust and debris that is separated from the air in the cyclone separation chamber. A dirt cup latch is mounted between the housing and the dirt cup to selectively bias the dirt cup into sealing engagement with the cyclone separation chamber.

In one embodiment, the dirt cup latch comprises a grip and a cam whereby the dirt cup is biased into sealing engagement with the cyclone separation chamber when the grip is placed in an upwardly vertical position and the dirt cup is disengaged from sealing engagement for removal from the cyclone separation chamber when the grip is placed in a downwardly vertical position.

In another embodiment, the dirt cup latch comprises a resilient biasing member. In a preferred embodiment, the biasing member is a compression coil spring.

BRIEF DESCRIPTION OF THE DRAWINGS

Embodiments of this invention will now be described though only by way of example. In the drawings:

FIG. 1 is a perspective view of an upright vacuum cleaner with a cyclone module assembly according to the invention.

FIG. 2 is an exploded right quarter perspective view of the cyclone module assembly of FIG. 1.

FIG. 3 is a cross-sectional view of the cyclone module assembly taken through line 3-3 of FIG. 1.

FIG. 4 is a cross-sectional view of the cyclone module taken through line 4-4 of FIG. 3.

FIG. 5 is a partial cross-sectional view of a portion of the vacuum cleaner of FIG. 1 taken through line 5-5 of FIG. 1 and illustrating a latch in an engaged position.

FIG. 5A is an enlarged view of the circled portion of FIG. 5 identified as FIG. 5A showing the latch in a disengaged position.

5 FIG. 6A is a front perspective view of the base of the vacuum cleaner of FIG. 1 with a portion of the latch exploded from a latch support of the latch mechanism of FIG. 5.

FIG. 6B is a right side rear perspective view of a portion of the base of the vacuum cleaner of FIG. 1 with a portion of the portion of the latch exploded from the
10 latch support as in FIG 6A.

FIG. 6C is a perspective view similar to FIG 6B with the latch portion assembled to the latch support.

FIG. 6D is an enlarged perspective view of a portion of the base of the vacuum cleaner of Fig. 1 showing the latch support without the latch portion therein.

15 FIG. 7 is an enlarged perspective view of a portion of the disassembled swing arm, hinge cap, and torsion spring of the foot assembly of the vacuum cleaner of FIG. 1.

FIG. 8 is a schematic view of one embodiment of a dirt cup latch according to the invention.

FIG. 9 is a schematic view of another embodiment of a dirt cup latch according
20 to the invention.

DESCRIPTION OF THE PREFERRED EMBODIMENT

Referring to the drawings, and particularly to FIG. 1, an upright vacuum cleaner 10 according to the invention comprises an upright handle assembly 12 pivotally mounted to a conventional foot assembly 14. The handle assembly 12 comprises a primary support section 16 with a grip 18 on one end to facilitate movement by the user. A motor cavity 20 is formed at an opposite end of the handle assembly 12 and contains a conventional fan/motor assembly (not shown) oriented transversely therein. The handle assembly 12 pivots relative to the foot assembly 14 through an axis formed relative to a shaft within the fan/motor assembly. A cyclone recess 24 provided by the primary support section 16 is configured to removably receive a cyclone module assembly 26 and dirt cup assembly 60.

The foot assembly 14 comprises a lower housing 28 that mates with an upper housing 30 to form a brush chamber 32 in a forward portion thereon. A rotating brush roll assembly 34 is positioned within the brush chamber 32. A pair of rear wheels 36 is secured to a rearward portion of the foot assembly 14, rearward being defined relative to the brush chamber 32. It is contemplated that a variety of foot assemblies 14 can be interchanged with the handle assembly 12 and other possible foot assembly configurations can be utilized.

A suction nozzle 38 (Fig. 5) is formed at a lower surface of the brush chamber 32 on the foot assembly 14 and is in fluid communication with the surface to be cleaned. An air conduit (not shown) provides an air path from the suction nozzle 38 through the foot assembly 14 and to the inlet aperture of the fan/motor assembly. A pet hair removal device 300 is included at a forward portion of the foot assembly.

The cyclone module assembly 26 separates and collects debris from a working air stream. After each cleaning operation is complete, or after a number of cleaning operations have been completed, the debris can be disposed of. As shown herein, the vacuum cleaner 10 is provided with a two stage cyclone module assembly 26, although
5 other cyclone module assemblies and other possible cyclone module configurations are contemplated.

Referring to FIGS. 2 and 3, the cyclone module assembly 26 comprises a cyclone separation housing 58 forming a second stage or second cyclone 62 that is substantially surrounded by a first stage or first cyclone 64. The cyclone separation
10 housing 58 comprises a first stage cyclone housing 70, first stage cyclone inlet 66, and a second stage cyclone outlet 68, which can be integrally molded. As illustrated, the first stage cyclone housing 70 is generally cylindrical and hollow in shape with a substantially closed top and an open bottom. Alternatively, the cyclone housing 70 can be tapered or formed having an inverted frusto-conical shape depending upon
15 manufacturing and aesthetic desires. The first stage cyclone inlet 66 comprises a generally cylindrical hollow conduit and can be formed integrally with the cyclone housing 70 at an upper portion thereof. In operation, first stage the cyclone inlet 66 is in fluid communication with the first cyclone. As illustrated, the second stage cyclone outlet 68 comprises a generally rectangular and hollow conduit formed integrally with
20 the cyclone housing 70 at an upper portion thereof. Alternatively, the second stage cyclone outlet 68 can have any shape suitable for the purposes described herein, such as a tubular shape. In operation, the second stage cyclone outlet 68 is in fluid communication with the second cyclone.

The cyclone module assembly 26 further comprises an upstream separator 84, a downstream separator 86, and a separator plate 88 that together form a cyclone separator 90. The upstream separator 84, downstream separator 86, and separator plate 88 can be integrally molded of a material suitable for the purposes described herein, such as plastic. Alternatively, the different parts of the cyclone separator 90 can be formed separately and attached to one another in any suitable manner, such as by gluing or welding.

The upstream separator 84 comprises two half-cylindrical members 85 positioned opposite each other and connected by an upstream flange 92 that depends horizontally outward from the uppermost edges of the cylindrical members 85. The half-cylindrical members 85 are equal in size and have open tops and bottoms. The half-cylindrical members 85 are positioned as if a cylinder was cut in half and one of the halves was moved slightly to one side relative to the other. This displacement creates two spaces between the ends of the half-cylindrical members 85 that form two second stage inlets 94 on radially opposite sides of the upstream separator 84.

The downstream separator 86 comprises a generally frusto-conical and hollow member 87 having an open bottom and top. The downstream separator 86 further comprises a downstream flange 96 depending generally horizontally outward from an uppermost edge of the frusto-conical member 87.

The separator plate 88 comprises a relatively thin, disc-like member 89 having a central opening sized to align with the bottom opening of the frusto-conical member 87. The disc-like member 89 is configured to fit coaxially within the cyclone housing 70. The disc-like member 89 is sized such that when assembled within the cyclone housing 70, a space exists radially between the circumference of the disc-like member 89 and

the cyclone housing 70. The separator plate 88 further comprises a lip 98 and a gasket-receiving member 99. The lip 98 comprises a thin wall positioned slightly below and vertically aligned with the central opening of the disc-like member 89. The lip 98 can have a substantially circular shape sized similarly to the central opening but having a slightly smaller area than the central opening such that debris and air can flow through the central opening and around the lip 98. The gasket-receiving member 99 is spaced from and surrounds a circumference of the lip 98 and is configured to receive a conventional gasket 100.

The cyclone separator 90 is formed such that the upstream separator 84 is coaxially aligned with the downstream separator 86. The cylindrical member 85 of the upstream separator 84 sits atop the downstream flange 96 such that the majority of the bottom opening of the cylindrical member 85 is in fluid communication with the top opening of the frusto-conical member 87. The separator plate 88 is aligned coaxially with the upstream separator 84 and downstream separator 86 such that a first stage debris outlet 102 is formed by the space existing between the circumference of the disc-like member 89 of the separator plate 88 and the cyclone housing 70. The central opening of the disc-like member 89 is also in fluid communication with the bottom opening of the frusto-conical member 87 such that the lip 98, gasket-receiving member 99, and gasket 100 together form a second stage debris outlet 104 enabling the passage therethrough of debris and air from the downstream separator 84 via the bottom opening of the frusto-conical member 87. The debris outlet 104 also functions as a vortex stabilizer.

The cyclone module assembly 26 further comprises a perforated grill 110. The perforated grill 110 comprises an inner grill cylinder 112, an outer grill cylinder 114,

and an upper wall 116 integrally formed with and connecting the top edges of the grill cylinders 112, 114. The inner and outer grill cylinders 112, 114 are concentric and have open bottoms. The outer grill cylinder 114 comprises a plurality of apertures 120 enabling the passage of air and debris therethrough. The apertures 120 are formed at an acute angle relative to the direction of flow of working air at an outer surface of the outer grill cylinder 114 during operation of the vacuum. The apertures 120 can be formed by injection molding using a tool with a plurality of slides and/or lifters having varying die-draw angles with respect to the vertical axes of the part. Each slide and/or lifter comprises a plurality of pins, that, when pulled during the ejection process, form the apertures 120 at varying angles with respect to the outer grill cylinder 114. The angular relationship between the longitudinal axis of the apertures 120 and the outer grill cylinder 114 preferably ranges from 10 degrees to 60 degrees.

When assembled, the upper wall 116 sits atop the upstream flange 92, and the outer grill cylinder 112 is configured and sized for placement around the upstream separator 84 such that the bottom edge of the outer grill cylinder 112 sits atop the downstream flange 96. The inner grill cylinder 114 is configured and sized for placement within the upstream separator 84 such that a bottom opening of the inner grill cylinder 114 is in fluid communication with the top opening of the downstream separator 86.

The dirt cup assembly 60 is positioned adjacent the cyclone separation housing 58 and is selectively sealingly mated to the cyclone housing 70 via a sealing lip 150 formed around the bottom edge of the cyclone housing 70 and a sealing ring 152. The sealing lip 150 is configured to receive the sealing ring 152 as well as an upper edge 154 of a dirt cup housing 160. The dirt cup housing 160 comprises an inner collection

cylinder 162 and an outer collection cylinder 164. The collection cylinders 162, 164 are concentric and substantially hollow. Both collection cylinders 162, 164 are open at their top ends but closed at their bottom ends. The inner collection cylinder 162 has a radius slightly smaller than that of the gasket 100 and also smaller than the outer
5 collection cylinder 164. The dirt cup housing 160 can include any number of additional features within one or both of the collection cylinders 162, 164.

When the cyclone module assembly 26 is assembled with the dirt cup assembly 60, a first stage collection area 166 is formed by the space between the outer circumference of the inner collection cylinder 162 and the dirt cup housing 160. A
10 second stage collection area 168, which is sealed off from the first stage collection area 166, is formed within the inner collection cylinder 162. The first stage collection area 166 is in fluid communication with the first stage cyclone 64, and debris can fall into the first stage collection area 166 from the first stage cyclone 64 via the first stage debris outlet 102. The separation plate 88 serves to reduce re-entrainment of debris
15 collected in the first stage collection area 166 into the first stage cyclone 64. The second stage collection area 168 is in fluid communication with the second stage cyclone 62 via the second stage debris outlet 104 to receive debris therethrough.

As indicated by the arrows shown in FIG. 3, in operation, the fan/motor assembly is positioned downstream of the second stage cyclone outlet 68. The
20 fan/motor assembly draws air from the first stage cyclone inlet 66 into the cyclone housing 70, causing the air to swirl around the inner wall of the cyclone housing 70 and the downstream separator 86 to form the first cyclone 64. The separation of larger debris occurs in the first cyclone 64 with the larger debris falling into the first stage collection area 166 of the dirt cup assembly 60 via the first stage debris outlet 102.

Referring also to FIG. 4, the air then travels passes through the perforated grill 110 and enters the cyclone separator 90 via the second stage inlets 94 of the upstream separator 84. The apertures 120 in the perforated grill 110 are formed at an acute angle relative to the working air flow, shown by the arrows labeled A, at the outer surface of the outer grill cylinder 114. In order for the air to pass through the apertures 120 in the perforated grill 110, the working air flow must change direction and reverse back as shown by the arrows labeled B. The change in the direction of working air flow propels debris out of the working air flow, which minimizes the debris passing through the apertures 120 and significantly reduces potential clogging.

Once through the perforated grill 110, the working air flows through the second stage inlets 94. The second stage inlets 94 direct the air tangentially and downwardly along an inside surface of the downstream separator 86. The airflow turns near the second stage debris outlet 104 and proceeds directly upward to the second stage outlet 68. The dirt removed by the frusto-conical downstream separator 86 falls into the second stage collection area 168.

The dirt cup assembly 60 can be detached from the cyclone housing 70 to provide a clear, unobstructed path for the debris captured in both the first stage collection area 166 and the second stage collection area 168 to be removed. Removal can be accomplished by inverting the dirt cup assembly 60.

Referring to FIGS. 1, 5 and 7, a pet hair removal device 300 is attached to a forward portion of the foot assembly 14. A pair of opposed hinge caps 302 are fixedly attached to an outer surface of the brush chamber 32. A pair of opposed swing arms 304 rotate within each hinge cap 302. A pair of torsion springs 301 (FIG. 7) are positioned between the hinge caps 302 and the swing arms 304 to bias the pet hair

removal device 300 in an upward position above the brush chamber 32 and away from the surface to be cleaned. Each of the torsion springs 301 can be received in a recess 303A in each swing arm 304. The recess 303A is configured to receive a coil 305A of the spring 301. A hook end 305B of the torsions spring 301 is retained by a flange 303B on the swing arm 304,. Each of the hinge caps 302 includes a spool 311 that
5 mounts the spring coil 305A and a securing recess 309 for receiving a second end 305C of each of the torsion springs 301. The spool 311 and spring 301 are received in the recess 303A.

A pet brush cover 306 is fixed to an end of the swing arms 304 opposite the
10 hinge caps 302. A pet hair remover 308 is attached to a lower portion of the pet brush cover 306 and comprises one of a number of commonly known hair removal materials. A pet brush bumper 310 comprising a relatively soft and/or resilient material can be affixed to a forward surface of the pet brush cover 306 to prevent damage to furnishings as is commonly known in the vacuum cleaner art. A more detailed description of a
15 suitable pet hair removal device is found in U.S. Patent Application Publication No. 2007/0143954 to Graham et al., which is incorporated herein by reference in its entirety.

As shown in FIGS. 5-6D, a latch mechanism 400 selectively secures the pet hair removal device 300 in an in-use position. The latch mechanism 400 comprises a latch portion 402 attached to or formed by the foot assembly 14 upper cover 30 and a catch
20 portion 404 attached to or formed with the pet hair removal device 300. The latch portion 402 further comprises a latch button 406 that slides vertically within a channel that is formed in a corresponding latch support 408 that is formed by or attached to the upper cover 30. A latch plate 409 is mounted to the inside of the channel formed by the latch support 408 and has a catching surface 418 and a chamfered surface 420 at a lower

portion thereof. An actuation surface 410 is formed on an upper surface of the latch button 406. The latch portion 402 is mounted to the latch support 408 through a pair of resilient fingers 422 that are slidably received in a slot 415 at a bottom of the latch support 408 as seen in FIG. 6D. The resilient fingers 422 have outwardly directed barbs on an outer end thereof for retaining the resilient fingers 422 in the slot 415 after the fingers have been mounted in the slot. The resilient fingers flex inwardly as the fingers are pushed into the slot 415 as the sides of the slot push against the barbs. The latch portion 402 further comprises a plurality of resilient latch fingers 424 that are positioned between the resilient fingers 422 and slide within the slot 415. Each of the latch fingers 424 has a disengaging portion 412 is formed on an opposite, lower surface. The disengaging surface 412 is preferably chamfered or angled relative to a vertical axis.

A pair of biasing members 405 in the form of resilient spring arms are integrally formed on a rear support of the latch portion 402 below the latch button 406. The biasing members 405 are cantilevered from the support and extend laterally outwardly and upwardly to rest on two support posts 407 that are formed on the latch support 408. The support posts 407 are spaced apart and extend upwardly from opposite sides of the latch support 408. When the latch portion 402 is assembled to the latch support 408, the biasing members 405 each press against a corresponding support post 407, which forces the latch portion 402 towards an uppermost position relative to the latch support 408. At the same time, the lower portion of the latch portion 402, including the disengaging surface 412, extends downward through an slot 415 at a bottom of the latch support 408.

The catch portion 404 is made of a resilient material and is fixed to the pet hair removal device 300 at one end by commonly know fastening mechanisms 413, such as screws, rivets, adhesives, ultrasonic welding, or the like. An end of the catch portion

404 opposite the fixed end comprises a releasing surface 414 that is chamfered or angled to mate with the disengaging portion 412 chamfered surface. A catch surface 416 is formed contiguous with the releasing surface 414. The latch support 408 further comprises a catching surface 418 and a chamfered surface 420 that corresponds to the releasing surface 414 of the catch portion 404.

In operation, the latch portion 402 is biased in the upward direction by the interaction between the biasing members 405 and the support posts 407. There is no force present between the disengaging portion 412 of the latch mechanism 400 and the releasing surface 414 of the catch portion 404. The pet hair removal device 300 maintains its position due to the interference of the catching surface 418 with the catch surface 416. This interference is created by the upward bias of the resilient catch portion 404.

To release the pet hair removal device 300, downward pressure is applied to the actuation surface 410, forcing the latch portion 402 down over the support posts 407 by overcoming the force provided by the biasing members 405 and moving the disengaging portion 412 into contact with the releasing surface 414. As the latch portion 402 moves further, the catch surface 416 deflects downwardly and moves below the chamfered surface 420 allowing the catch surface 416 to clear the catching surface 418. The torsion springs in the hinge caps 302 bias the pet hair removal device 300 to a position above the foot 14 and away from the surface to be cleaned.

To place the pet hair removal device 300 back into the in-use position, the user grasps the pet brush cover 306 and rotates the device about the hinge caps 302 until the releasing surface 414 contacts the chamfered surface 420. The catch portion 404 deflects in a downward direction, and the releasing surface 414 slides past the

chamfered surface 420. The catch portion 404 returns to its normal or straight position, and the catch surface 416 interfaces with the catching surface 418 to lock the pet hair removal device 300 into the in-use position.

Referring to FIGS 1 and 8, the vacuum cleaner 10 further includes a dirt cup
5 latch assembly 500 for use in mounting the dirt cup assembly 60 in the recess 24 and to
the cyclone module assembly 26. In the illustrated embodiment, the cyclone module
assembly 26 is mounted to the handle 12. However, it is possible in other embodiments
that the cyclone module assembly 26 is removably mounted within the recess 24 and
can be attached to the dirt cup assembly 60, which can in turn be used to mount both
10 itself and the attached cyclone module assembly 26 to the vacuum cleaner 10. The dirt
cup latch assembly 500 comprises a latch assembly 502 and a support platform 504.
The latch assembly 502 comprises a pivot bearing 506 in spaced relation to a cam
surface 508. The pivot bearing 506 is secured to a pivot support 509 that is anchored to
a floor of the recess 24. A lever 510 extends away from the pivot bearing 506 toward
15 the forward portion of the handle 12 and is accessible to the user via a grip 512. The
cam surface 508 contacts a lower surface 516 of the support platform 504 while a lower
portion of the dirt cup housing 160 removably contacts an upper surface 518 of the
support platform 514.

In operation, the lever 510 is placed in its lowermost position (shown in dotted
20 lines), moving the support platform 504 down and thus creating the maximum space
between the upper surface 518 of the support platform 504 and the lip 150 on the
cyclone separation housing 58. The dirt cup assembly 60 is placed on the upper surface
518 of the support platform 504 within the recess 24. The user lifts the lever 510 via the
grip 512, which rotates the latch assembly 502 about the pivot bearing 506. This action

moves the cam surface 508 relative to the lower surface 516 of the support platform 504. The extended length of the cam surface 508 moves the support platform 504 upwardly (shown in solid lines) and, with it, the dirt cup assembly 60, until the upper edge 154 of the dirt cup housing 150 sealingly engages with the lip 150 on the cyclone separation housing 58. An over-center design is implemented with the pivot bearing 506 relative to the cam surface 508 so that the latch assembly 502 remains in the upward or latched position.

Referring to FIGS 1 and 9I, an alternate dirt cup assembly latching mechanism comprises a biasing member 520 in place of the latch assembly 502 previously described. In this embodiment, the biasing member 520 is positioned between the recess 24 and the lower surface 516 of the support platform 504. In operation, the dirt cup assembly 60 is placed on the upper surface 518 of the support platform 504 and the user pushes down on the dirt cup housing 160, compressing the biasing member 520 until the upper surface of the dirt cup housing 160 clears the lip 150 in the cyclone module 26. Once the upper edge 154 of the dirt cup housing 160 is positioned within the lip 150, the user releases the dirt cup housing 160, the biasing member 520 expands vertically, and the dirt cup housing 160 seals at the lip 150.

While the invention has been specifically described in connection with certain specific embodiments thereof, it is to be understood that this is by way of illustration and not of limitation. It is anticipated that the cyclone separators described herein can be utilized for both dry and wet separation. Furthermore, the features described can be applied to any cyclone separation device utilizing a single cyclone, or two or more cyclones arranged in any combination of series or parallel airflows. In addition, whereas the invention has been described with respect to an upright vacuum cleaner, the

invention can also be used with other forms of vacuum cleaners, such as canister or central vacuum cleaners. Reasonable variation and modification are possible within the forgoing disclosure and drawings without departing from the scope of the invention as defined in the appended claims.

CLAIMS

1. A vacuum cleaner comprising:
 - a cleaning head assembly having a suction nozzle adapted to be moved along a surface to be cleaned;
 - a hair collection assembly having a hair collection element adapted to collect hair from the surface to be cleaned, wherein the hair collection assembly is mounted to the cleaning head for movement of the hair collection element between a first position in which the hair collection element is in contact with the surface to be cleaned, and a second position, in which the hair collection element is spaced from the surface to be cleaned; and
 - 10 a latch assembly mounted to the cleaning head and the hair collection assembly to selectively retain the hair collection assembly in contact with the surface to be cleaned.
2. The vacuum cleaner according to claim 1 wherein the latch assembly comprises a latch portion as a part of one of the cleaning head assembly and the hair collection assembly and a catch portion as a part of the other of the cleaning head assembly and the hair collection assembly.
- 15 3. The vacuum cleaner according to claim 2 wherein the latch portion is a part of the cleaning head assembly and the catch portion is part of the hair collection assembly.
- 20 4. The vacuum cleaner according to claim 3 wherein the catch portion is made of a resilient material.

5. The vacuum cleaner according to claim 4 wherein the latch portion includes a disengaging member that is adapted to selectively deform the catch portion to release the latch assembly when the disengaging member is actuated by a user.

6. The vacuum cleaner according to claim 2 and further comprising a spring
5 biasing member that biases the hair collection assembly to the second position to move the hair collection assembly from the first position to the second position when the catch portion is released from the latch portion.

7. The vacuum cleaner according to claim 1 and further comprising a spring
10 biasing member that biases the hair collection assembly to the second position to move the hair collection assembly from the first position to the second position when the latch assembly is released.

8. A vacuum cleaner comprising:
a cleaning head assembly having a suction nozzle;
a suction source to create a flow of working air;
15 a cyclone module assembly in fluid communication with the suction nozzle and the suction source, and comprising:

a cyclone separation chamber for separating dust and debris from
air, the cyclone separation chamber having an inlet opening in fluid communication
with the suction nozzle through the working air path, an outlet opening for discharging
20 cleaned air and a particle discharge outlet for discharging dust and debris separated
from air;

a dirt cup in fluid communication with the particle discharge
outlet for collecting dust and debris that is separated from the air in the cyclone
separation chamber; and

an exhaust grill in the cyclone separation chamber to filter out larger debris, the exhaust grill comprising a plurality of apertures whereby a leading edge of the aperture forms an acute angle relative to the flow of working air.

9. The vacuum cleaner according to claim 8 wherein the acute angle is
5 between 10 degrees and 60 degrees.

10. A vacuum cleaner comprising:
a cleaning head assembly having a suction nozzle;
a housing coupled to the cleaning head assembly;
a suction source mounted in the housing for creating a flow of working
10 air;

a cyclone module assembly mounted in the housing in fluid communication with the suction nozzle and the suction source, and comprising:
a cyclone separation chamber for separating dust and debris from air, the cyclone separation chamber having an inlet opening in fluid communication
15 with the suction nozzle through the working air path, an outlet opening for discharging cleaned air and a particle discharge outlet for discharging dust and debris separated from air; and

a dirt cup removably mounted to the cyclone separation chamber and in fluid communication with the particle discharge outlet for collecting dust and
20 debris that is separated from the air in the cyclone separation chamber; and

a dirt cup latch between the housing and the dirt cup to selectively bias the dirt cup into sealing engagement with the cyclone separation chamber.

11. The vacuum cleaner of claim 10 wherein the dirt cup latch comprises a grip and a cam whereby the dirt cup is biased into sealing engagement with the cyclone

separation chamber when the grip is placed in an upwardly vertical position and the dirt cup is disengaged from sealing engagement for removal from the cyclone separation chamber when the grip is placed in a downwardly vertical position.

12. The vacuum cleaner of claim 10 wherein the dirt cup latch comprises a
5 resilient biasing member.

13. The vacuum cleaner according to claim 9 wherein the biasing member is
a compression coil spring.

14. A vacuum cleaner as claimed in one of claims 1, 8 or 10 and
substantially as hereinbefore described with reference to and as illustrated in the
10 accompanying drawings.



Application No: GB0904362.1

Examiner: Mr Michael Young

Claims searched: 1-7

Date of search: 8 May 2009

Patents Act 1977: Search Report under Section 17

Documents considered to be relevant:

Category	Relevant to claims	Identity of document and passage or figure of particular relevance
X	1 at least	US 2008/0086831 A1 (YOO) See features 200,210,201,247 fig.1 & corresponding passages.
X	1 at least	GB 2447355 A (BISSELL) See feature 38 figs.9 & 10, and corresponding passages.

Categories:

X	Document indicating lack of novelty or inventive step	A	Document indicating technological background and/or state of the art
Y	Document indicating lack of inventive step if combined with one or more other documents of same category.	P	Document published on or after the declared priority date but before the filing date of this invention.
&	Member of the same patent family	E	Patent document published on or after, but with priority date earlier than, the filing date of this application

Field of Search:

Search of GB, EP, WO & US patent documents classified in the following areas of the UKC^X:

Worldwide search of patent documents classified in the following areas of the IPC

A47L

The following online and other databases have been used in the preparation of this search report

WPI EPODOC

International Classification:

Subclass	Subgroup	Valid From
A47L	0009/00	01/01/2006