

(No Model.)

J. BARKER.
FERRULE FOR HANDLES.

No. 277,404.

Patented May 8, 1883.

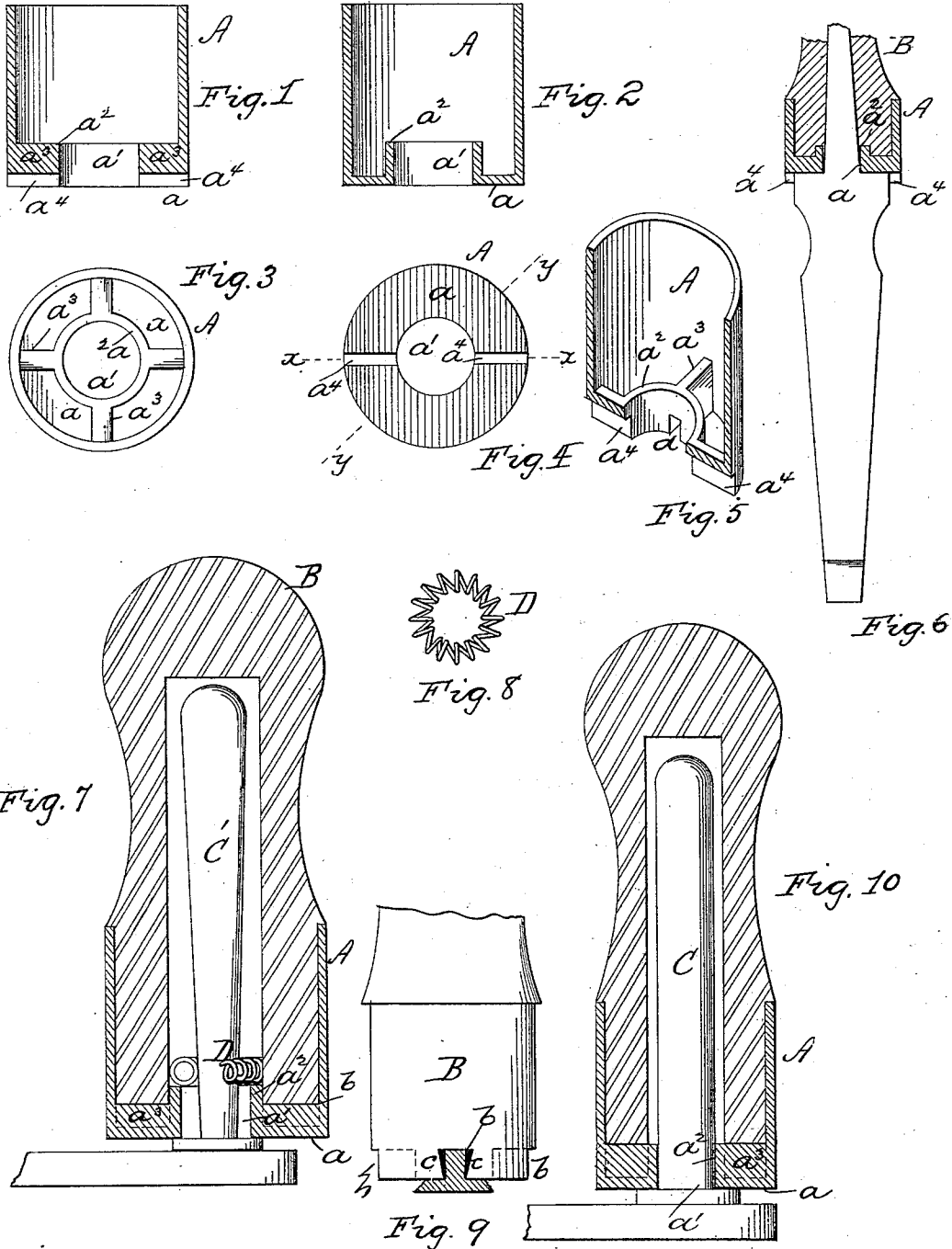

Witnesses:
J. Thompson
W. Ruppert

Inventor
John Barker
By S. J. Vanstaveoren
Attorney.

UNITED STATES PATENT OFFICE.

JOHN BARKER, OF PHILADELPHIA, PENNSYLVANIA, ASSIGNOR OF ONE-HALF TO ABRAM C. BROWN, OF SAME PLACE.

FERRULE FOR HANDLES.

SPECIFICATION forming part of Letters Patent No. 277,404, dated May 8, 1883.

Application filed July 1, 1882. (No model.)

To all whom it may concern:

Be it known that I, JOHN BARKER, a subject of the Queen of Great Britain, residing at Philadelphia, in the county of Philadelphia and State of Pennsylvania, have invented certain new and useful Improvements in Ferrules for Handles, of which the following is a specification, reference being had therein to the accompanying drawings, wherein—

Figure 1 is a vertical section of my improved ferrule on line *x x*, Fig. 4. Fig. 2 is a like view on line *y y*, Fig. 4. Fig. 3 is a top view or plan. Fig. 4 is a bottom view or inverted plan. Fig. 5 is a sectional perspective. Fig. 6 is an elevation of a screw-driver with my improved ferrule applied to the handle thereof, the latter being in section. Fig. 7 is a like view of said ferrule applied to tapering handles of car-brake-operating rods or cranks. Fig. 8 is a detail plan of spring used in conjunction with such handles. Fig. 9 is an elevation, partly sectional, illustrating the dovetail connection between the handle and the ferrule; and Fig. 10 is a section of handle and ferrule applied to a straight or cylindrical car-brake handle.

My invention has for its object to provide an improved ferrule for tool, car-brake, and other handles; and it consists in the novel construction and arrangement of the ferrule, as hereinafter described and claimed.

Referring to the accompanying drawings, A represents the body of the ferrule, having a bottom face, *a*, with central opening, *a'*. Surrounding the latter is a circumferential flange, *a²*, projecting into the body of the ferrule, as shown, and *a³ a³* are lugs or ribs connecting such flange and the sides of the ferrule.

a⁴ a⁴ represent aligning grooves or recesses in the face *a* of the ferrule. These grooves are provided for the reception of the end of a screw-driver or bit, as shown in Fig. 6, so that said driver or bit abuts against metal or the ferrule, and not against the wood of the handle B, as heretofore, the result whereof is that there is not so much wear between the screw-driver and its handle, thereby making the connection between such parts more durable than has heretofore been the case. The lugs or ribs *a³* are provided for preventing the handle B turning in the ferrule, and to obviate the with-

drawal of the handle from the ferrule the former is provided with dovetail slots *b b*, which are filled with shellac or other suitable varnish previous to inserting the handle into the ferrule. When such insertion is made, the entrance of the lugs or ribs *a³* into the slots *b b* causes the varnish therein to collect at the widest or upper parts of said slots, as shown at *c*, Fig. 9. Such varnish, when it dries, adheres to the ribs and to the sides of the slots *b b*, and firmly retains the ferrule upon the handle. The flange *a²* is provided to secure a metal bearing-surface for the handle to revolve upon, thereby preserving the wood of the handle from undue wear. Such advantage is especially noticeable when my improved ferrules are applied to the handles used upon the lever for operating street-car brakes, as shown in Figs. 7 and 10. The last-named figure shows a straight or cylindrical rod, C, thereon, upon which the handle B is placed. The flange *a²*, bearing against rod C, protects the wood of handle B from too rapid deterioration.

In Fig. 7 a tapering rod, C', is shown, and in such cases a spring, D, is placed between said rod and handle B, as illustrated, and serves to keep the latter in a perpendicular position. Such spring is more plainly shown in Fig. 8.

The ferrule may be made of any suitable material and of any desired size.

When applied to handles designed to be used upon car-brake levers, the slots or grooves *a⁴* may be dispensed with. So, too, if desired, the lugs or ribs *a³* may be dispensed with, and a screw passing through the body A into handle B may be substituted therefor.

What I claim as my invention is—

1. A ferrule having body A, bottom or face *a*, with central opening, *a'*, and circumferential flange *a²*, projecting into said body, substantially as shown and described.

2. A ferrule having body A, bottom or face *a*, with opening *a'*, flange *a²*, and lugs or ribs *a³*, substantially as shown and described.

3. A ferrule having body A, bottom or face *a*, with opening *a'*, flange *a²*, slots *a⁴ a⁴*, and lugs or ribs *a³*, substantially as shown and described.

4. The ferrule having body A, with face *a*, opening *a'*, flange *a*², lugs or ribs *a*³, and, in combination therewith, handle B, having dovetailed slots *b*, adapted and designed to be
5 connected to ribs *a*³ by shellac or other suitable varnish, substantially as shown and described.

5. The ferrule A, having face *a*, opening *a'*, flange *a*², and lugs or ribs *a*³, and, in combina-

tion therewith, the spring D, substantially as 10 and for the purpose set forth.

In testimony whereof I affix my signature in presence of two witnesses.

JOHN BARKER.

Witnesses:

S. J. VAN STAVOREN,
CHAS. F. VAN HORN.