



US00D954467S

(12) **United States Design Patent**
Chiquin

(10) **Patent No.:** **US D954,467 S**

(45) **Date of Patent:** **** Jun. 14, 2022**

(54) **SIDE CHANNEL**

D271,055 S 10/1983 Cascone et al.

4,452,294 A 6/1984 Fukuchi

D294,321 S 2/1988 Olofsson

(Continued)

(71) Applicant: **Edwin Chiquin**, Miami, FL (US)

(72) Inventor: **Edwin Chiquin**, Miami, FL (US)

(73) Assignee: **VERTILUX LIMITED**, Medley, FL (US)

FOREIGN PATENT DOCUMENTS

AU 2009203048 10/2015
BG 6230-0011 9/2006

(Continued)

(**) Term: **15 Years**

(21) Appl. No.: **29/710,244**

OTHER PUBLICATIONS

(22) Filed: **Oct. 22, 2019**

Bing Search; <http://www.quebanana.com/tienda/ver/herraiasmario/145224>; Aug. 22, 2013.

(Continued)

(51) **LOC (13) Cl.** **06-10**

(52) **U.S. Cl.**

USPC **D6/580**; D25/123

(58) **Field of Classification Search**

USPC D6/575-581; D25/119-125, 164; D26/138

CPC ... A47H 1/04; A47H 1/06; A47H 1/10; A47H 1/12; A47H 1/122; A47H 1/124; A47H 1/14; A47H 1/142; A47H 1/144; A47H 2001/047; E06B 2009/587; E06B 9/24; E06B 9/58

See application file for complete search history.

Primary Examiner — Llorellys Martinez

(74) *Attorney, Agent, or Firm* — Malloy & Malloy, PL; Peter A. Matos

(57) **CLAIM**

The ornamental design for a side channel, as shown and described.

DESCRIPTION

FIG. 1 is a front perspective view of a side channel showing my new design;

FIG. 2 is a right side view thereof;

FIG. 3 is a rear view thereof;

FIG. 4 is a front view thereof;

FIG. 5 is a top view thereof;

FIG. 6 is a rear bottom perspective view thereof;

FIG. 7 is a left side view thereof;

FIG. 8 is a rear perspective view thereof;

FIG. 9 is a bottom view thereof; and,

FIG. 10 is a bottom rear perspective view.

The broken lines in the drawings represent environmental subject matter only and form no part of the claimed design.

(56) **References Cited**

U.S. PATENT DOCUMENTS

1,909,109 A	5/1933	Kopfstein	
2,549,905 A	4/1951	Jablon	
3,297,075 A	1/1967	Howell et al.	
3,402,421 A	9/1968	Weber	
3,417,519 A	12/1968	Hitter	
3,454,073 A	7/1969	Man	
3,524,491 A	8/1970	Olson	
4,122,559 A	10/1978	Kelly	
4,197,896 A	4/1980	Reichstadt	
D259,810 S *	7/1981	Dallaire	D25/122
D260,183 S *	8/1981	Dallaire	D25/119
4,393,915 A	7/1983	Olson	

1 Claim, 10 Drawing Sheets

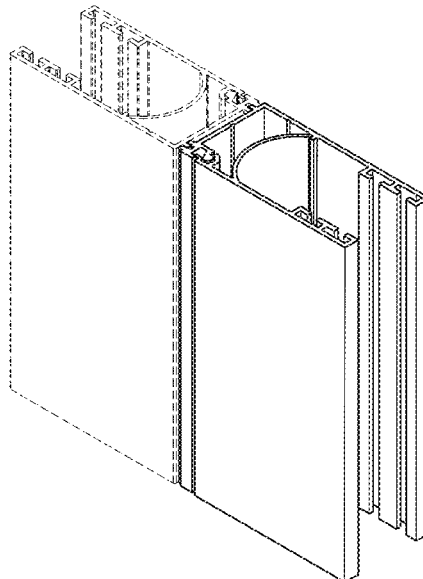

(56)

References Cited

U.S. PATENT DOCUMENTS

4,840,216	A	6/1989	John		D691,398	S	10/2013	Chou
4,935,988	A	6/1990	Ford et al.		D692,685	S	11/2013	Chou
4,987,943	A	1/1991	Charest		D694,039	S	11/2013	Licciardi Di Stefano
5,137,073	A	8/1992	Huang		D694,040	S	11/2013	Di Stefano
5,232,039	A	8/1993	Shapiro et al.		8,584,317	B2	11/2013	Liebscher et al.
5,259,687	A	11/1993	John		D695,042	S	12/2013	Licciardi Di Stefano
5,271,687	A	12/1993	Holka et al.		D697,335	S	1/2014	Dekker et al.
D345,498	S	3/1994	Fraser et al.		D699,976	S	2/2014	Chou
5,296,964	A	3/1994	Shopp		D710,128	S	8/2014	Garcia
5,330,821	A	7/1994	Lo		D715,629	S	10/2014	Grubb et al.
D353,209	S *	12/1994	Dallaire	D25/123	8,960,621	B2	2/2015	Wills
D355,094	S	2/1995	Josephson		D727,659	S	4/2015	Kao
D355,604	S	2/1995	De Baschmakoff		9,004,142	B2	4/2015	Marocco
5,647,421	A	7/1997	Hoffman et al.		9,038,696	B2	5/2015	Lava et al.
D382,651	S *	8/1997	Colitto	D25/122	9,060,636	B2	6/2015	Cannaverde
D382,652	S *	8/1997	Colitto	D25/122	D740,589	S	10/2015	Ng
5,803,144	A	9/1998	Ives		D742,138	S	11/2015	Chou
D405,194	S	2/1999	Kenkel		9,175,512	B2	11/2015	Lu et al.
5,924,255	A	7/1999	Vagedes		D753,933	S	4/2016	Ng
5,975,186	A	11/1999	Day		D759,400	S	6/2016	Watkins
5,983,972	A	11/1999	Chou		D762,398	S	8/2016	Ng
D429,588	S	8/2000	Smederod		9,498,079	B2	11/2016	Sanchuk
6,111,694	A	8/2000	Shopp		D775,939	S	1/2017	Ng
6,173,825	B1	1/2001	Liu		D780,945	S	3/2017	Guillemi
6,196,508	B1	3/2001	Nijs		D789,454	S	6/2017	Prisnie
6,202,967	B1	3/2001	Fraczek		D791,580	S	7/2017	Chou
D440,099	S	4/2001	Hortsen		D793,765	S	8/2017	Chou
6,230,782	B1	5/2001	Reichert		D798,133	S	9/2017	Ng
6,234,233	B1	5/2001	Biro		D808,684	S	1/2018	Santilli
6,269,909	B1	8/2001	Grimes et al.		D808,685	S *	1/2018	Raiti
6,408,922	B2	6/2002	Desrochers		D813,570	S	3/2018	Santilli
D468,453	S	1/2003	Schrader		9,976,346	B2	5/2018	Ng
6,532,109	B1	3/2003	Shopp		D822,228	S	7/2018	Wang et al.
D479,934	S	9/2003	Colson et al.		D828,052	S	9/2018	Bouroullec et al.
6,666,251	B2	12/2003	Ikle		D833,175	S	11/2018	Miroshnichenko et al.
D489,209	S	5/2004	Goldberg		D843,130	S	3/2019	Bacal
6,739,373	B1	5/2004	Liu et al.		D843,131	S	3/2019	Chou
D492,809	S	7/2004	Weitgasser		10,309,153	B2	6/2019	McPherson
D494,401	S	8/2004	Davies et al.		D854,192	S *	7/2019	Rokvic
6,817,399	B2	11/2004	Berman et al.		D854,855	S	7/2019	Garcia Garcia
6,817,402	B1	11/2004	Fraczek et al.		D854,856	S	7/2019	Garcia Garcia
6,978,821	B2	12/2005	Welfonder		10,407,905	B2	9/2019	Neal
7,048,028	B2	5/2006	Wolfe et al.		10,544,621	B2	1/2020	Mocanu et al.
D530,967	S	10/2006	Smith		D878,103	S	3/2020	Bacal
7,141,164	B2	11/2006	Slack et al.		10,619,412	B2	4/2020	Chen et al.
7,168,475	B2	1/2007	Colson et al.		D885,084	S	5/2020	Chiquin
D537,173	S *	2/2007	Westphal	D25/124	10,648,230	B2	5/2020	Holt et al.
7,195,052	B2	3/2007	Nien et al.		D911,064	S	2/2021	Holt et al.
D542,068	S	5/2007	Watkins		D920,004	S	5/2021	Chiquin
7,210,513	B2	5/2007	Goldenberg et al.		D940,477	S	1/2022	Chiquin
D557,116	S	12/2007	Zakowski		2003/0178276	A1	9/2003	Fraczek et al.
7,353,857	B2	4/2008	Koop		2004/0129391	A1	7/2004	Gottschall et al.
7,367,536	B1	5/2008	Anderson et al.		2004/0182522	A1	9/2004	Strand
7,380,582	B1	6/2008	Anderson et al.		2005/0247413	A1	11/2005	Nien et al.
D573,267	S	7/2008	Brinton et al.		2005/0269044	A1	12/2005	Nien
D577,138	S	9/2008	Kitagawa et al.		2006/0000559	A1	1/2006	Bohlen
D591,442	S	4/2009	Ford et al.		2006/0049325	A1	3/2006	Jung
D596,435	S	7/2009	Willis		2006/0113046	A1	6/2006	Prince et al.
D599,051	S	8/2009	Wu et al.		2006/0243402	A1	11/2006	Chang
D604,885	S	11/2009	Ford et al.		2007/0169900	A1	7/2007	Chen et al.
7,614,439	B2	11/2009	Lukos		2007/0221344	A1	9/2007	Beach et al.
D616,567	S *	5/2010	Desrosiers	D25/125	2007/0284051	A1	12/2007	Grimes et al.
D616,568	S *	5/2010	Desrosiers	D25/125	2008/0035281	A1	2/2008	Kirby
7,770,625	B2	8/2010	Lukos		2008/0245489	A1	10/2008	Chuang et al.
D628,715	S	12/2010	Gosling et al.		2009/0229767	A1	9/2009	Mullet et al.
D634,573	S	3/2011	Risher		2009/0250177	A1	10/2009	Byeon
7,921,602	B2	4/2011	Ohanesian		2009/0258752	A1	10/2009	Bohlen et al.
7,997,041	B2	8/2011	Slack et al.		2010/0101741	A1	4/2010	Koop
D652,568	S *	1/2012	Trzesniowski	D26/138	2010/0175838	A1	7/2010	Faller et al.
8,136,569	B2	3/2012	Bohlen et al.		2010/0300631	A1	12/2010	Sullivan
8,220,520	B2	7/2012	Lukos		2011/0006176	A1	1/2011	Krantz-Lilienthal
D675,050	S	1/2013	Garcia		2011/0049071	A1	3/2011	Hart et al.
D680,357	S	4/2013	Wills		2011/0114809	A1	5/2011	Ng
8,480,048	B2	7/2013	Krantz-Lilienthal		2012/0012262	A1	1/2012	Santoro
8,528,623	B2	9/2013	Roberts		2012/0031572	A1	2/2012	Ng et al.
					2012/0061034	A1	3/2012	Ng
					2012/0097346	A1	4/2012	Ng
					2012/0255686	A1	10/2012	Huang
					2013/0048229	A1	2/2013	Dwarka

(56)

References Cited

U.S. PATENT DOCUMENTS

2013/0068405	A1	3/2013	Lava et al.	
2013/0098563	A1	4/2013	Jang	
2013/0176743	A1	7/2013	Pfund et al.	
2014/0009519	A1	1/2014	Kumagai et al.	
2014/0048218	A1	2/2014	Ng	
2014/0251558	A1	9/2014	Chou	
2014/0262076	A1	9/2014	Mullet	
2014/0305602	A1	10/2014	Kirby et al.	
2014/0352897	A1	12/2014	Mullet	
2015/0027059	A1	1/2015	Lu	
2015/0047792	A1	2/2015	Lukosiunas et al.	
2015/0075726	A1	3/2015	Byun	
2015/0240851	A1*	8/2015	Giacometti	E04F 11/1812 403/374.3
2015/0275571	A1	10/2015	Guhl	
2015/0292261	A1	10/2015	Chou	
2015/0292262	A1	10/2015	Miller et al.	
2015/0297014	A1	10/2015	Cannaverde	
2015/0368970	A1	12/2015	Chambers et al.	
2016/0032646	A1	2/2016	Fleischman	
2016/0051074	A1	2/2016	Chou	
2016/0090779	A1	3/2016	Nurre et al.	
2016/0130869	A1	5/2016	Cheng	
2016/0298375	A1*	10/2016	Wagner	E04F 11/1812
2016/0326800	A1	11/2016	Marocco	
2016/0340972	A1	11/2016	Chou	
2017/0009519	A1	1/2017	Marocco	
2017/0079459	A1	3/2017	Filko	
2017/0114593	A1	4/2017	Hebeisen et al.	
2018/0087319	A1	3/2018	McPherson	
2018/0202157	A1	7/2018	Neal	
2019/0264499	A1	8/2019	McNeill et al.	
2019/0352963	A1	11/2019	Jang	
2020/0052515	A1	2/2020	Nien et al.	
2020/0095825	A1	3/2020	Chen et al.	
2020/0131846	A1	4/2020	Hebeisen et al.	

2020/0208464	A1	7/2020	Guest et al.
2020/0355026	A1	11/2020	Liu
2021/0310299	A1	10/2021	Chiquin

FOREIGN PATENT DOCUMENTS

BG	6230-0016	9/2006
BR	3020120013798	2/2013
BR	3020120056900	3/2016
CN	2012300548304	3/2013
CN	2012303568969	4/2013
CO	282	7/2012
CO	751520	10/2012
EM	000113899-0003	4/2003
EM	000275839-0002	12/2004
EM	000279633-0001	1/2005
EM	000518923-0001	4/2006
EM	000795752-0001	9/2007
EM	001084370-0013	2/2009
EM	001102875-0002	3/2009
EM	0013369940001	7/2012
EM	003342013-0012	8/2016
GB	2052622	12/1995
GB	2391577	2/2004
MX	38640	5/2013
PE	002031-2018	1/2019
WO	WO D068016-0004	6/2006
WO	WO D086931-0004	6/2015

OTHER PUBLICATIONS

Rollashade; Contract Series; <https://www.rollashade.com/contract.html>; Feb. 5, 2018.

Rolleaseacmeda; System—Quick Reference Guide; https://www.rolleacmeda.com/docs/default-source/default-document-library/edge-side-channels_qrg_us_v1-0.pdf?sfvrsn=0&sfvrm=0; Feb. 5, 2018.

* cited by examiner

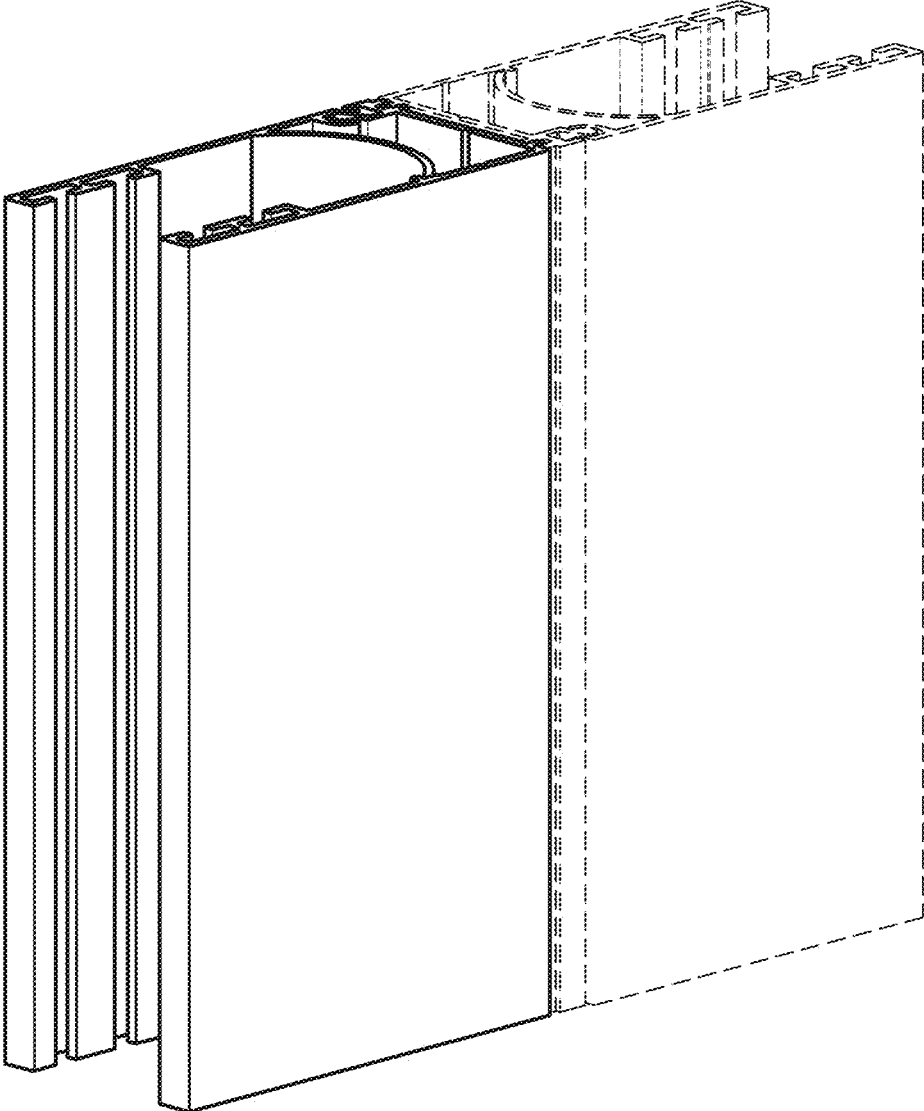

FIG. 1

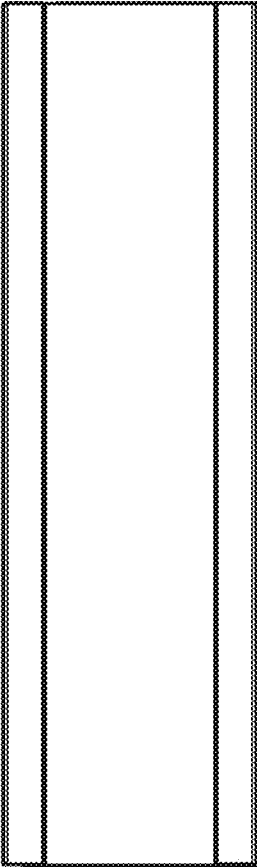

FIG.2

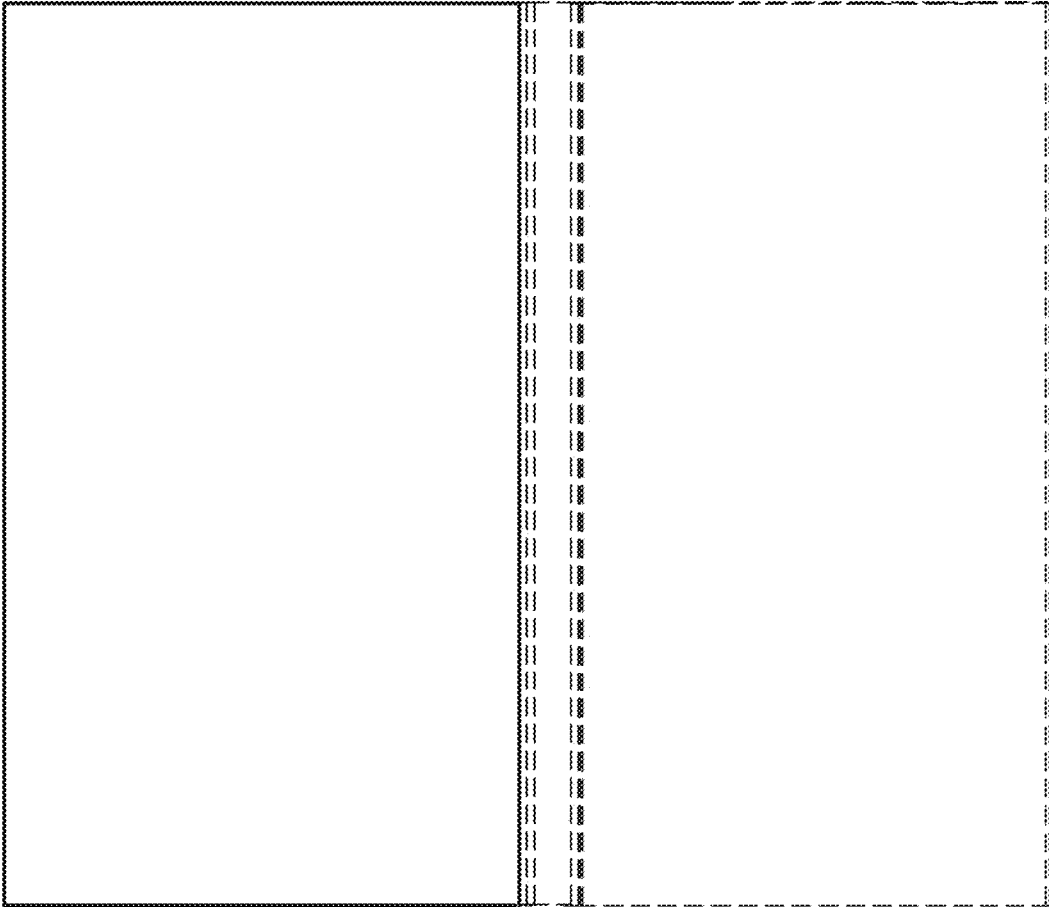

FIG.3

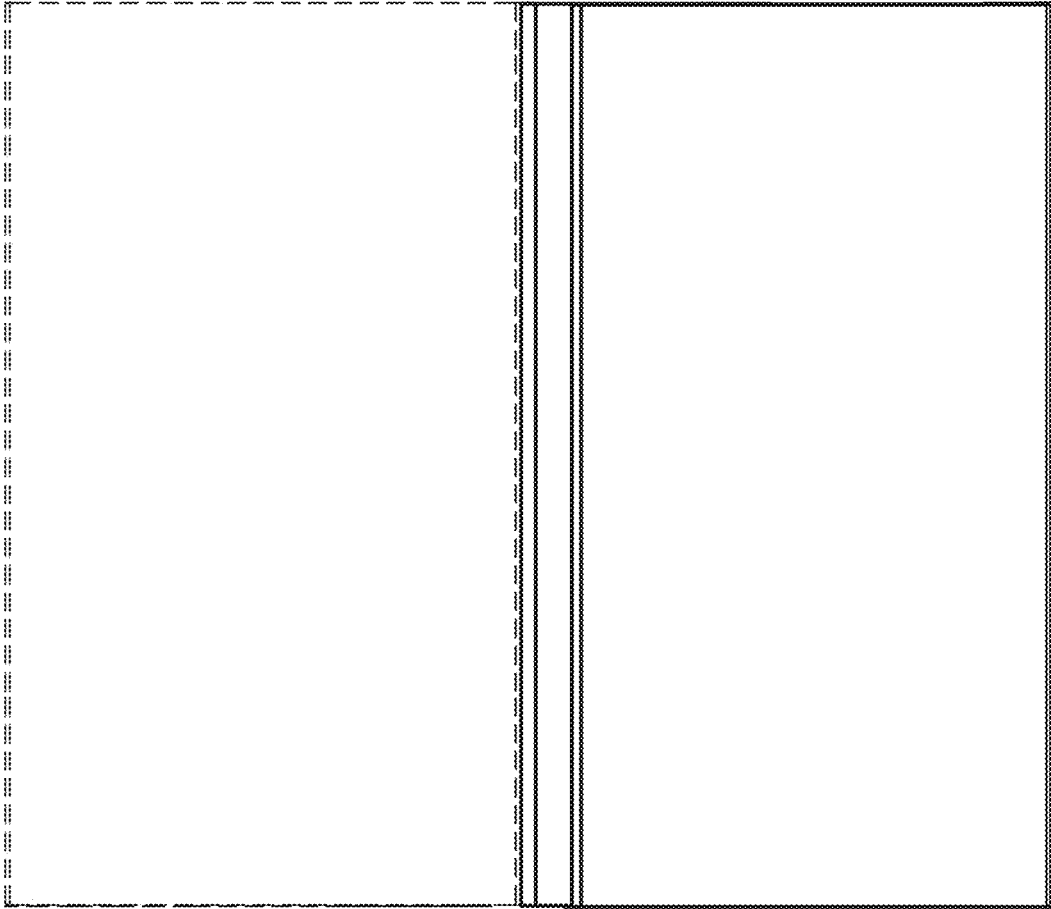

FIG.4

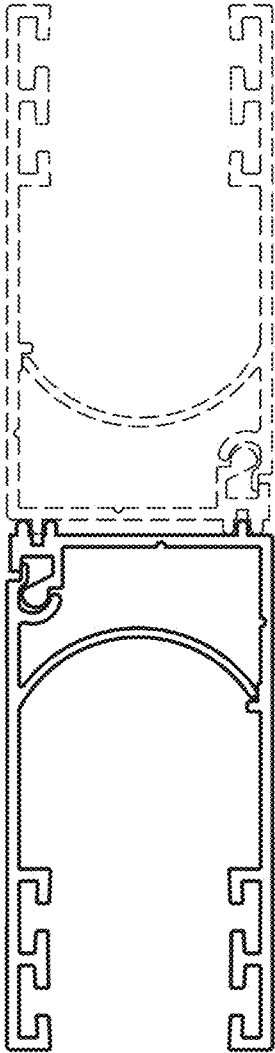

FIG.5

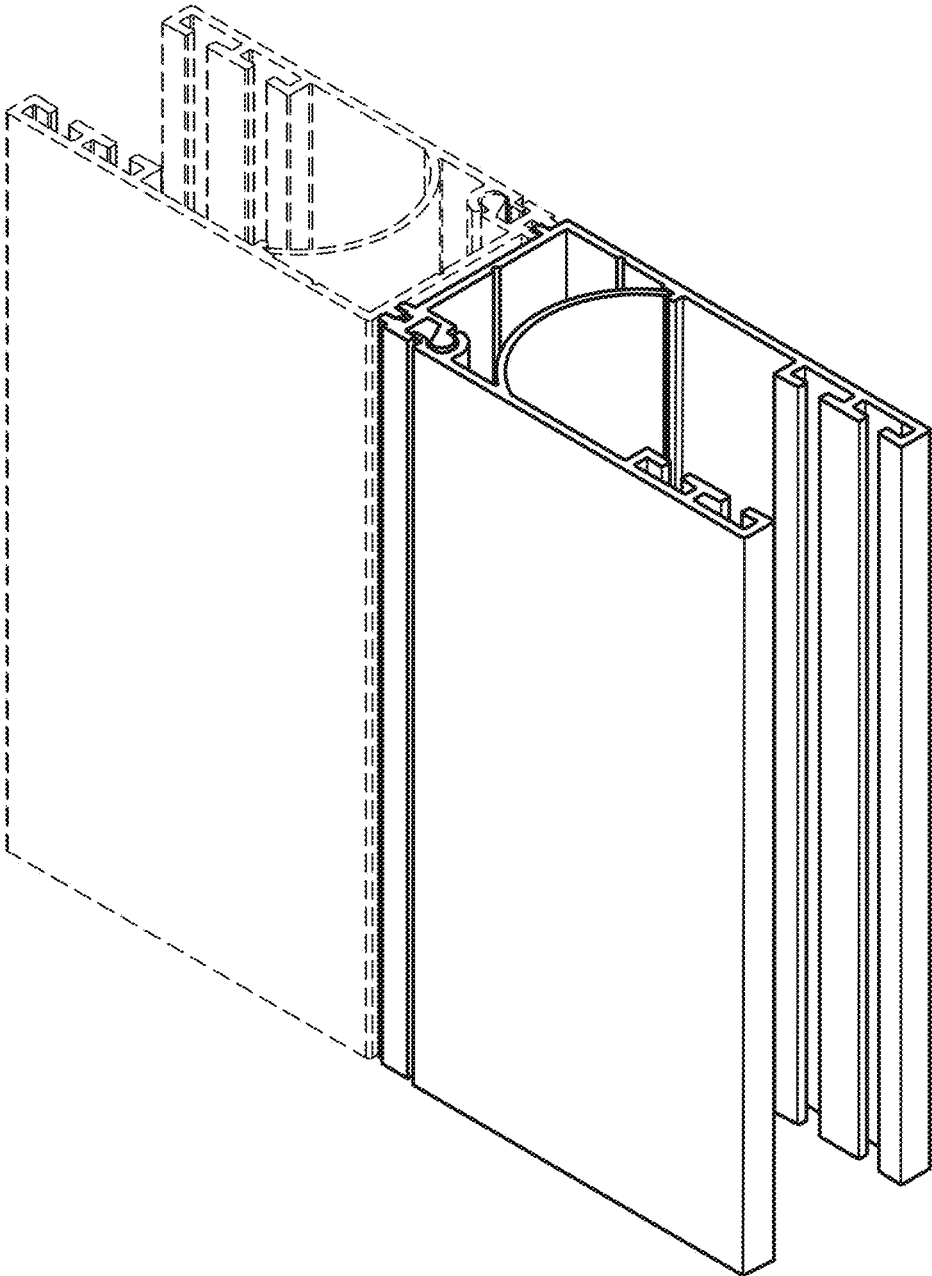

FIG.6

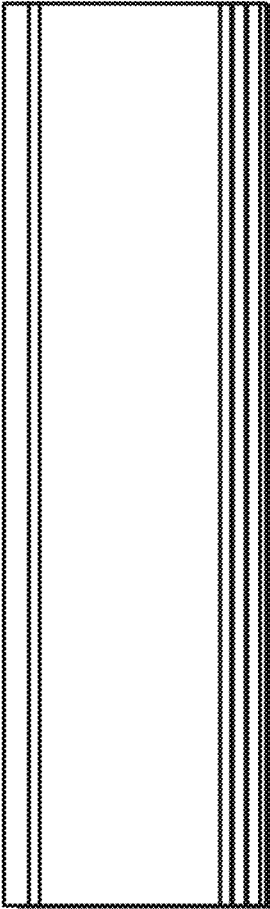

FIG.7

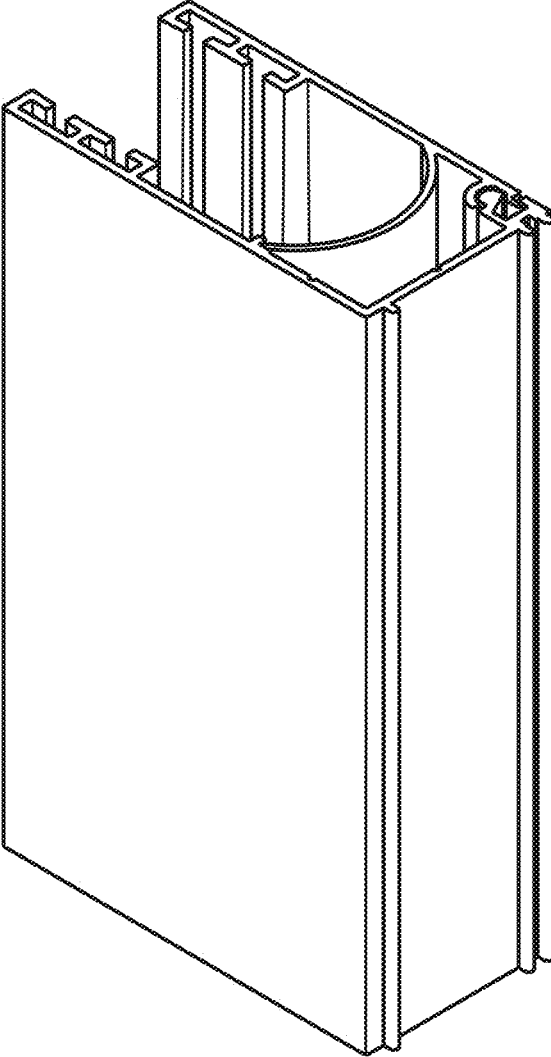

FIG.8

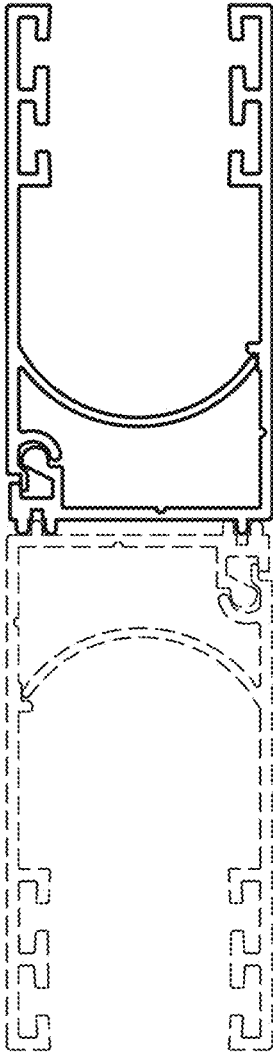

FIG.9

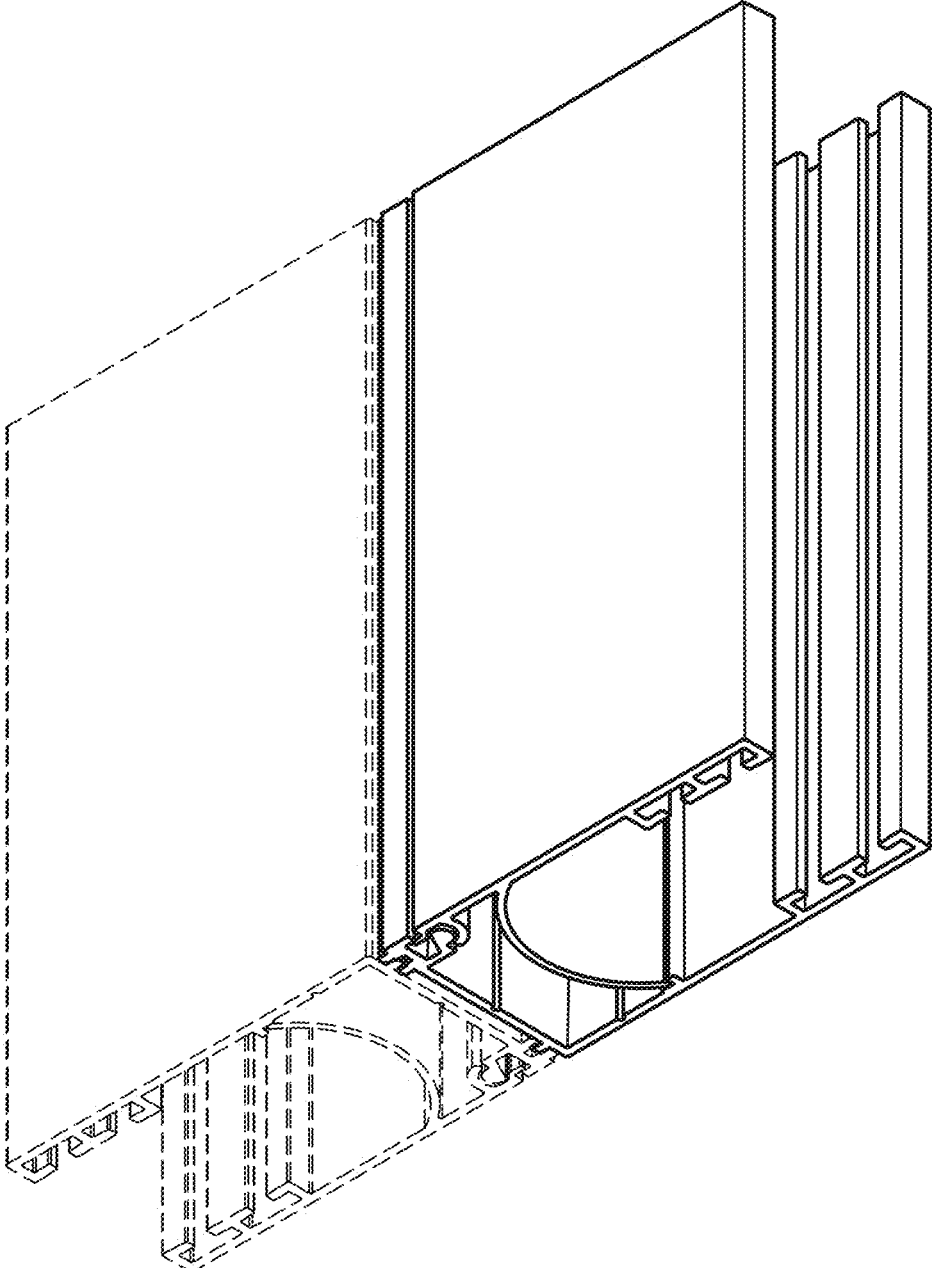

FIG. 10