



US 20080093255A1

(19) **United States**

(12) **Patent Application Publication**  
**Greaves et al.**

(10) **Pub. No.: US 2008/0093255 A1**

(43) **Pub. Date: Apr. 24, 2008**

(54) **GOLF ACCESSORY KIT**

**Publication Classification**

(76) Inventors: **Keiron W. Greaves**, Wayside, NJ (US);  
**Robert M. Stoute**, Ocean, NJ (US)

(51) **Int. Cl.**  
**A63B 57/00** (2006.01)

(52) **U.S. Cl.** ..... **206/579**; 473/406; 473/408

Correspondence Address:  
**RAYMOND R. MOSER JR., ESQ.**  
**MOSER IP LAW GROUP**  
**1030 BROAD STREET**  
**2ND FLOOR**  
**SHREWSBURY, NJ 07702 (US)**

(57) **ABSTRACT**

(21) Appl. No.: **11/975,824**

(22) Filed: **Oct. 22, 2007**

**Related U.S. Application Data**

(60) Provisional application No. 60/862,242, filed on Oct. 20, 2006.

A golf accessory kit comprises a base, a lid, and several compartments contained therein. The structure of the golf accessory kit may be rectangular, square, oval, or any other shape desirable for a golfer to use. The compartments within the golf accessory kit are capable of self-sealing, thereby keeping the golf accessory kit organized with separate golf accessories contained in separate compartments.

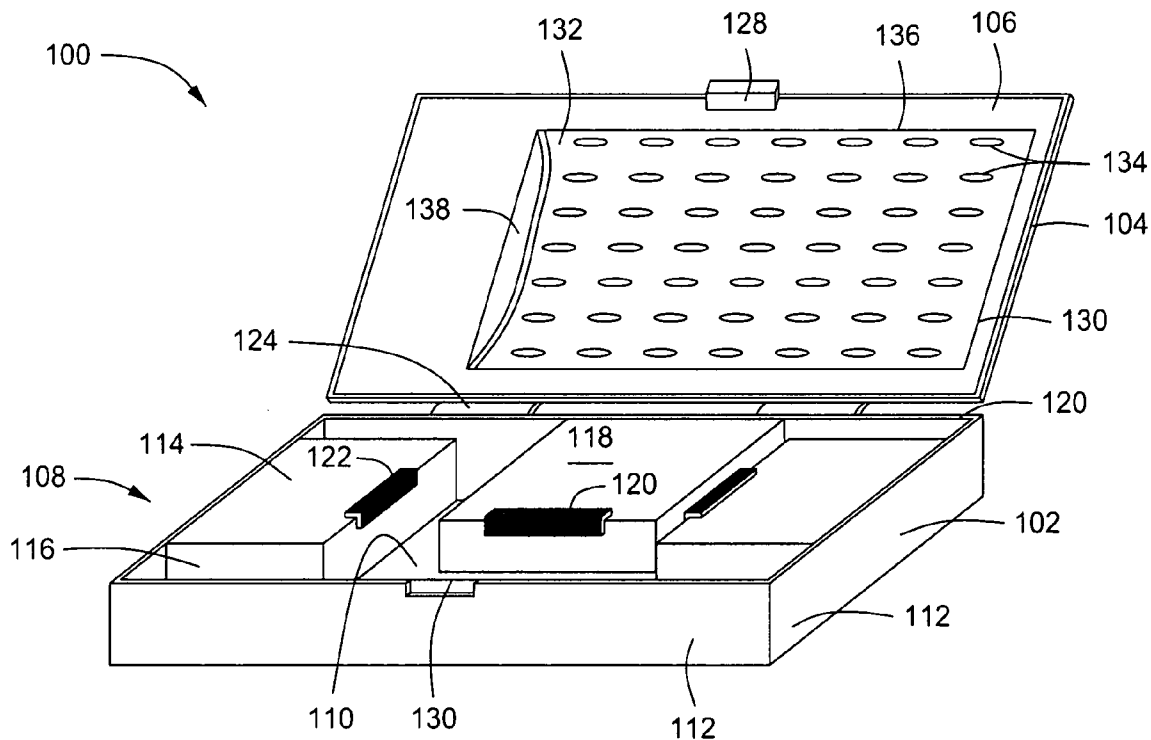

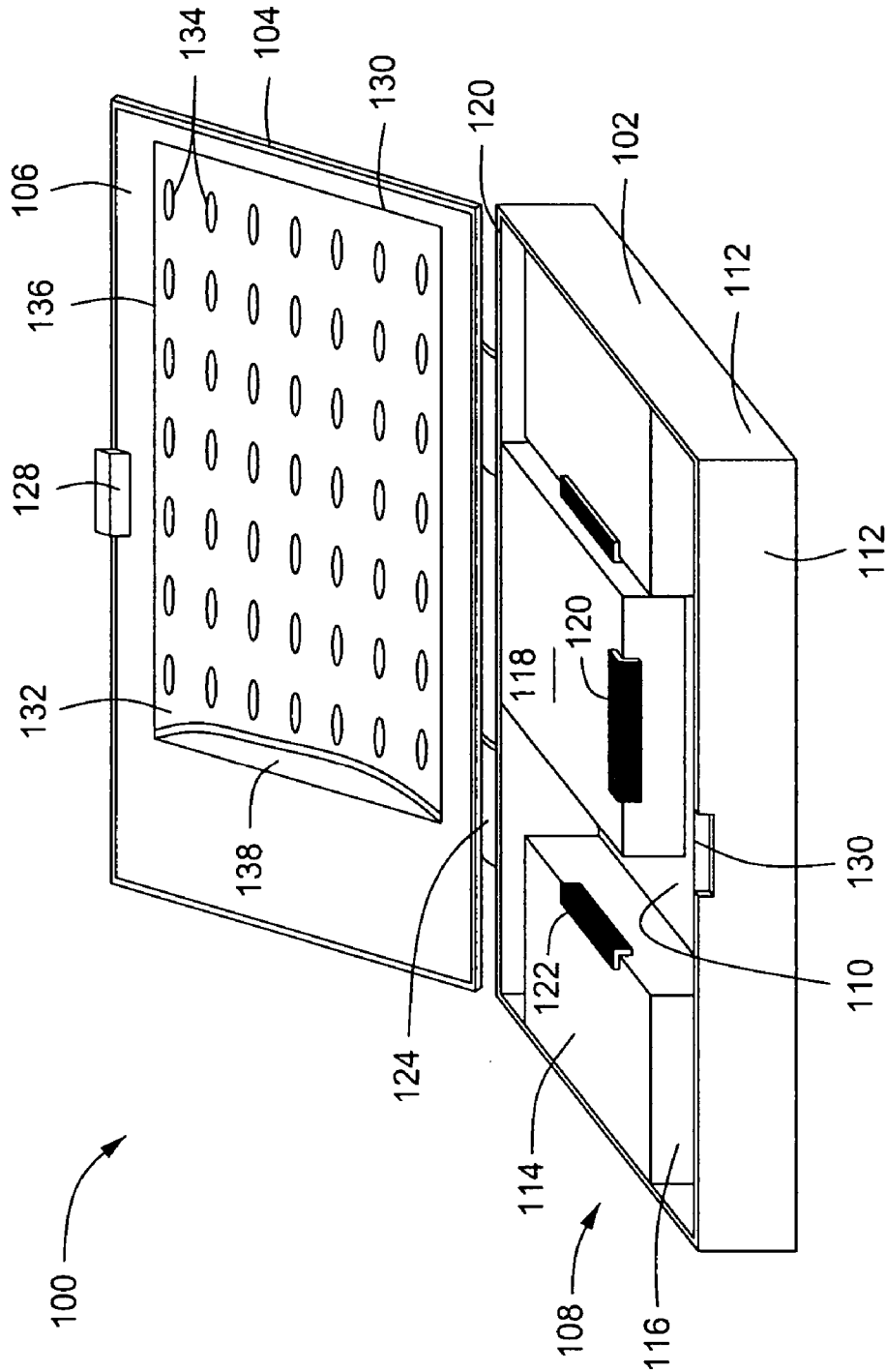

FIG. 1

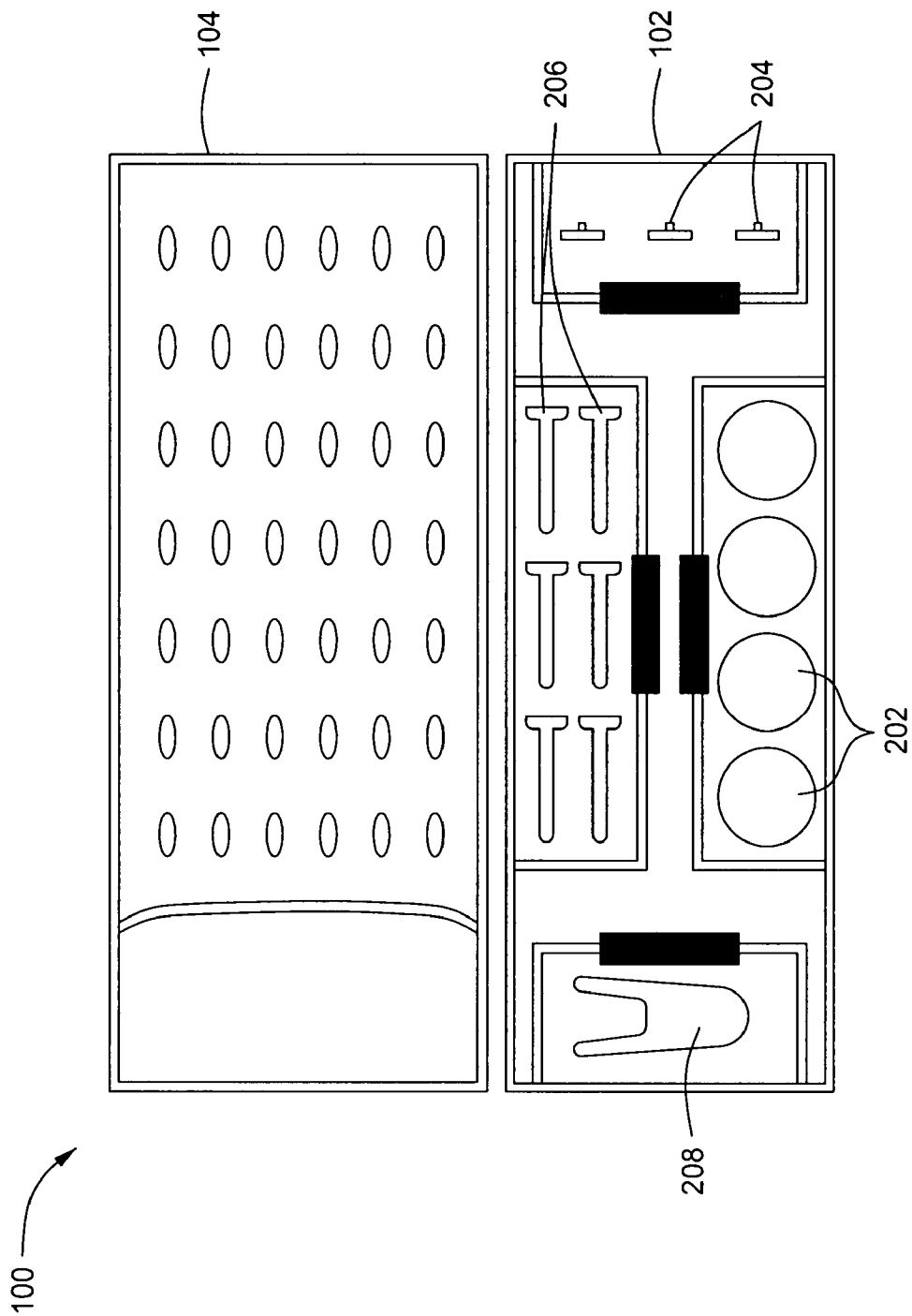

FIG. 2

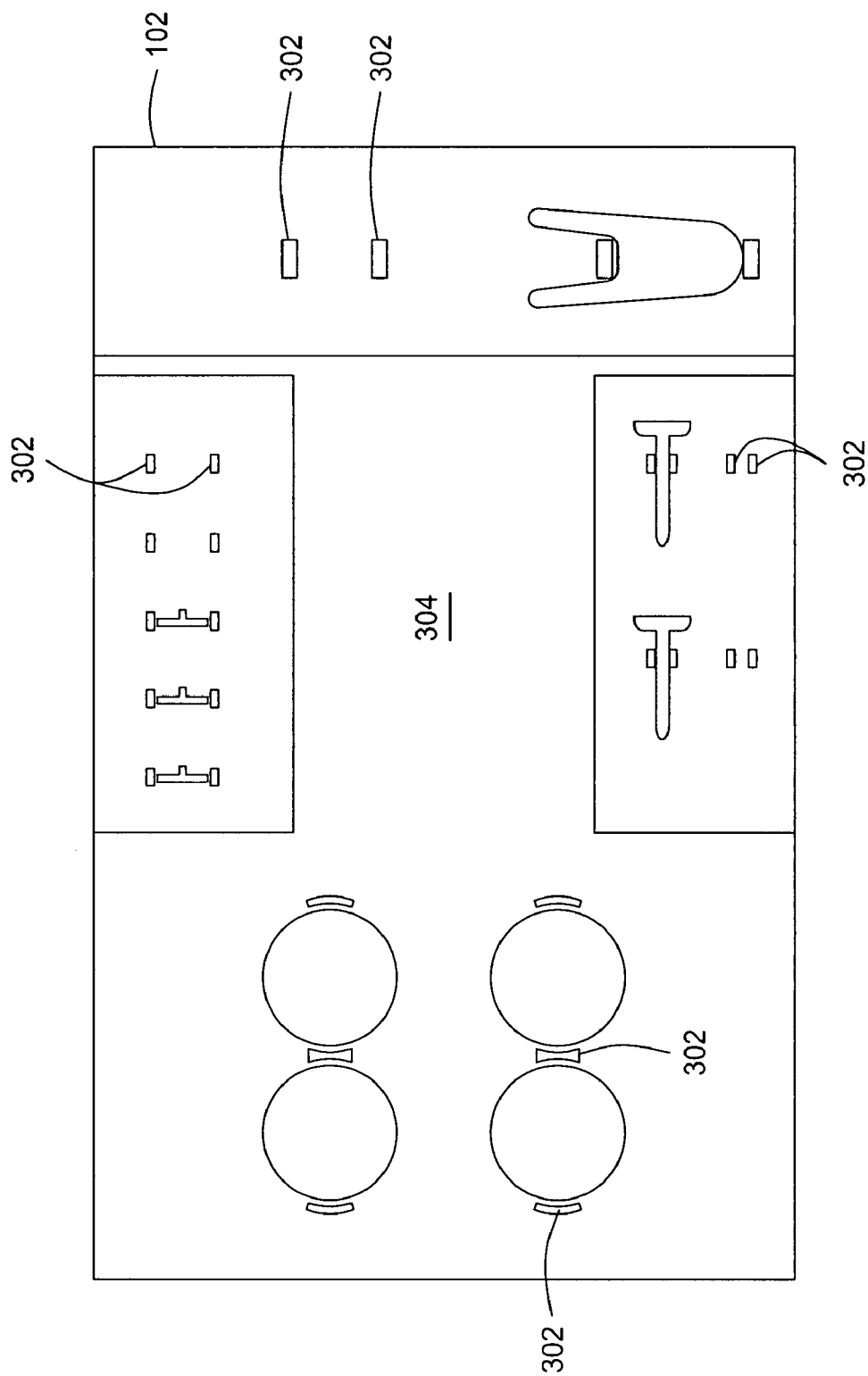

FIG. 3

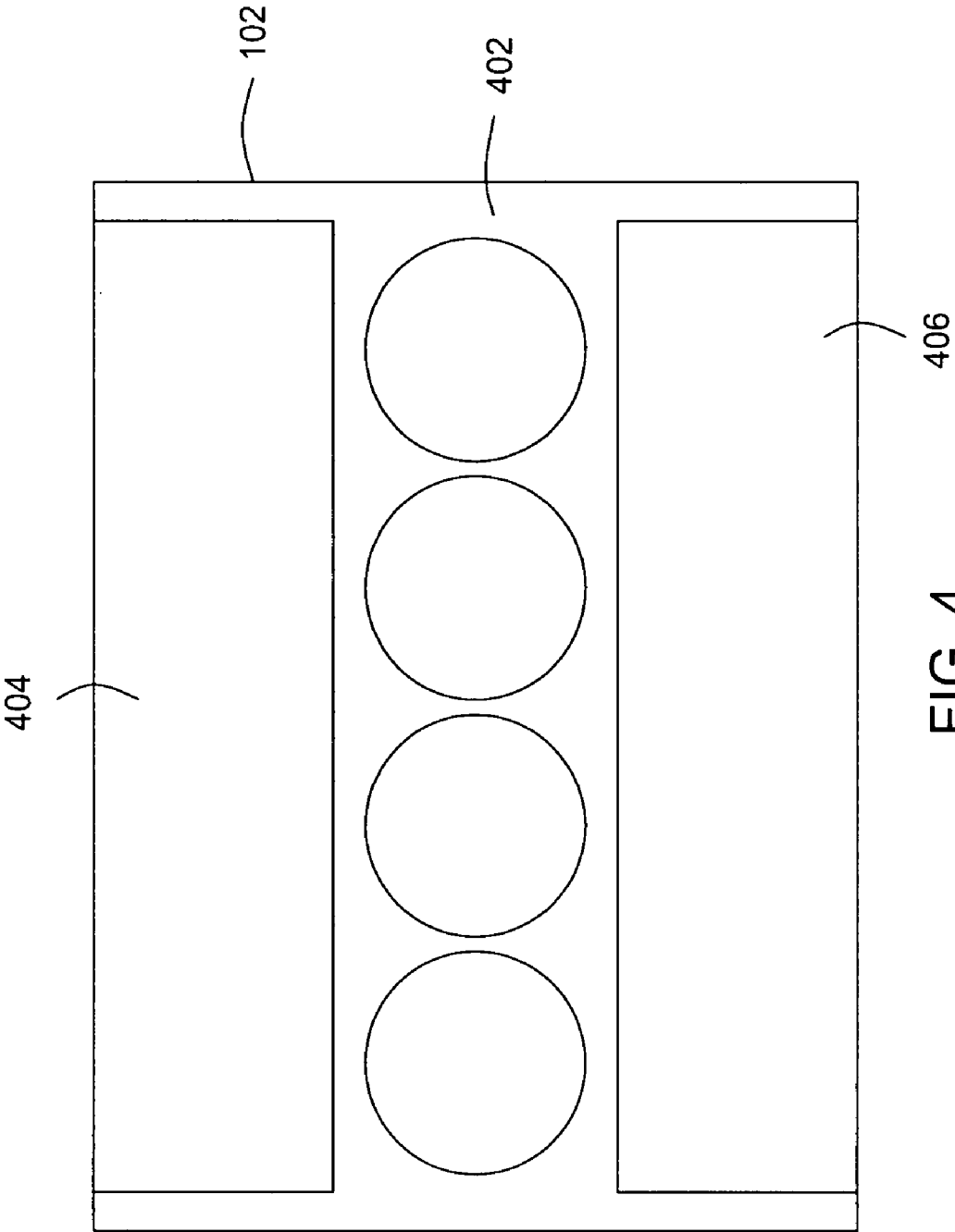

FIG. 4

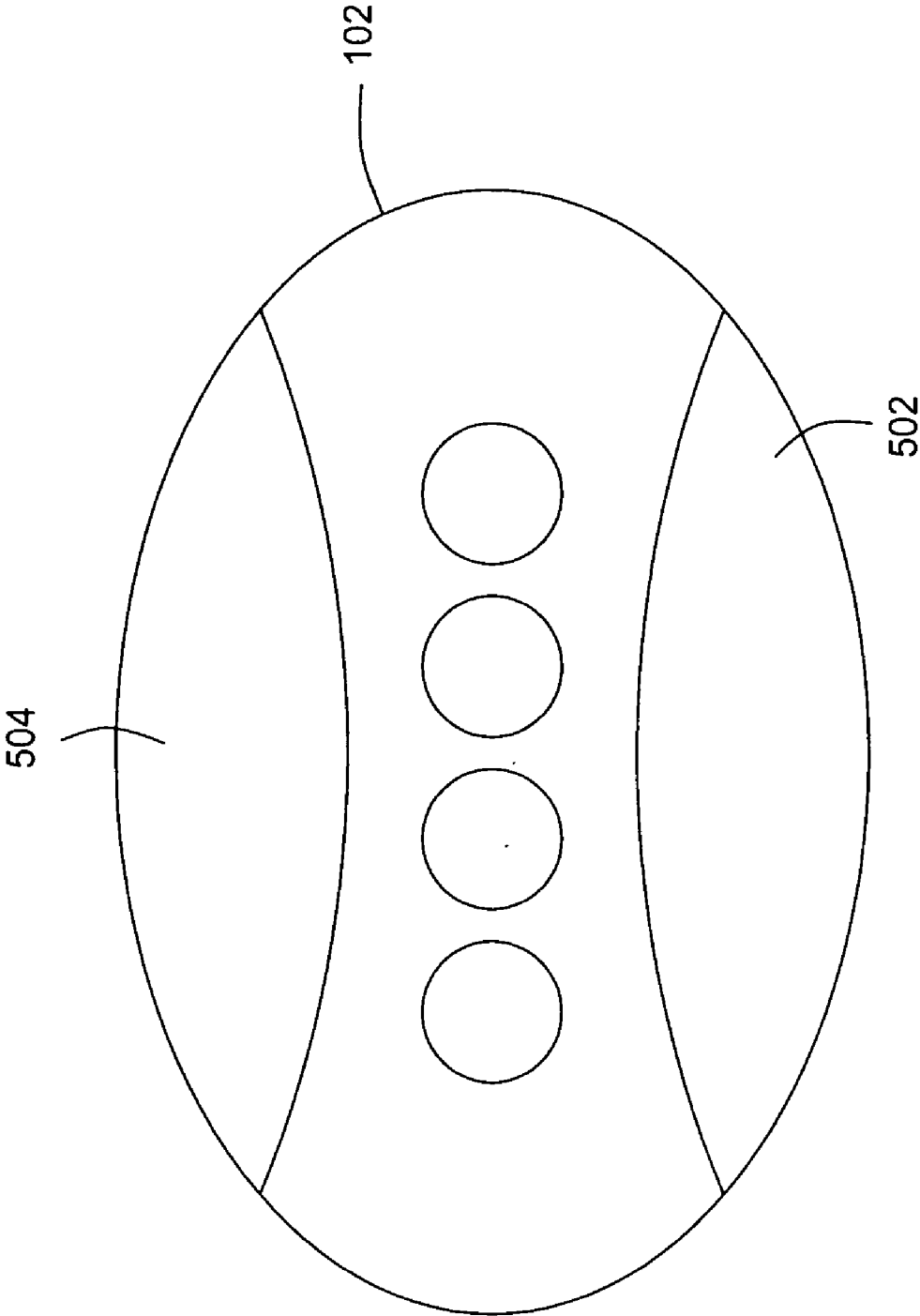

FIG. 5

## GOLF ACCESSORY KIT

### CROSS REFERENCES

[0001] This application claims the benefit of U.S. Provisional Application No. 60/862,242, filed on Oct. 20, 2006, which is herein incorporated by reference.

### BACKGROUND OF THE DISCLOSURE

[0002] 1. Field of the Invention

[0003] Embodiments of the present invention generally relate to a golf accessory kit for arranging a golfer's accessories, personal items, and the like.

[0004] 2. Description of the Related Art

[0005] The sport of golf has existed for hundreds of years. What originated as a game involving one stick and one ball has integrated with science and technology to yield the game known today. Modern advancements in the sport of golf include an expansive selection of golf clubs, use of golf cleats, varying golf tees, breathable golf gloves, a plethora of golf ball enhancements, among many others. Due to these advancements, the modern golfer usually stores and carries a range of golf accessories to accommodate any situation on the golf course.

[0006] Golf accessories generally include golf tees, golf balls, divot-repair tools, ball markers, golf pencils, and the like. Some accessories are stored at all times until needed, while others are stored between rounds of golf and are placed in the golfer's pocket or other readily-accessible locations while the golfer is on the golf course. Most golfers use a golf bag with its several pockets to store these accessories. However, this can often lead to lost and tangled accessories whereas the items within the pockets of the golf bag become disorderly as the golf bag is moved around.

[0007] Thus, there is a need for a golf accessory kit that structures and stores golf accessories.

### SUMMARY OF THE INVENTION

[0008] Embodiments of the present invention relate to a golf accessory kit. In one embodiment of the present invention, a golf accessory kit comprises a base, a lid, and several compartments contained therein. The structure of the golf accessory kit may be rectangular, square, oval, or any other shape desirable for a golfer to use. The compartments within the golf accessory kit are capable of self-sealing, thereby keeping the golf accessory kit organized with separate golf accessories contained in separate compartments.

### BRIEF DESCRIPTION OF THE DRAWINGS

[0009] Additional object and features of the invention will be more readily apparent from the following detailed description and appended claims when taken in conjunction with the drawings, in which;

[0010] FIG. 1 depicts a perspective view of a golf accessory kit in accordance with one embodiment of the present invention;

[0011] FIG. 2 depicts a top plan view of the golf accessory kit of FIG. 1;

[0012] FIG. 3 depicts a top plan view of a golf accessory kit in accordance with a second embodiment of the present invention;

[0013] FIG. 4 depicts a top plan view of a golf accessory kit in accordance with a third embodiment of the present invention; and

[0014] FIG. 5 depicts a top plan view of a golf accessory kit in accordance with a fourth embodiment of the present invention.

### DETAILED DESCRIPTION OF THE DRAWINGS

[0015] FIG. 1 depicts a perspective view of a golf accessory kit **100** in accordance with one embodiment of the present invention. A golf accessory kit **100** generally comprises a base **102**, a lid **104** having an inner surface **106**, an interior portion **108** of the base **102** defined by a bottom surface **110** and four sidewalls **112**, and at least a compartment **114** contained within the inner portion **108** of the base **102**. Each compartment **114** generally comprises compartment sidewalls **116** and an optional compartment lid **118**.

[0016] As depicted in FIG. 1, a golf accessory kit **100** may be substantially rectangular in shape. Other known configurations such as circular, oval, square, triangular, or other conceivable and practical shapes are contemplated. The shape may be determined by either the practical aspects of storing the golf accessory kit **100** in a golfer's golf bag (not shown) or may be selected by a golfer's preference and style. The material comprising the golf accessory kit **100** may be plastic, metal, wood, or any other malleable material. In one embodiment, the golf accessory kit **100** is made of molded plastic. In another embodiment, it is desirable to form a golf accessory kit **100** from a transparent or substantially transparent material, such as, for example, polycarbonate. The size of the golf accessory kit **100** may also vary. These variations will be determined by the practicality and necessity of storing a golfer's accessories or may be selected by the golfer's style and preference.

[0017] The interior portion **108** of the base of the golf accessory kit **100** comprises at least a compartment **114**. The compartment **114** is generally configured within the interior portion **108** to maximize the useful space therein. In one embodiment, three compartments **114** are provided within the interior portion **108** of the base **102** and may be used to store individual golf accessories. These accessories may include golf balls, golf tees, ball-repair markers, divot-repair tools, golf pencils, and the like.

[0018] The compartments **114** may optionally be provided with a compartment lid **118**. In one embodiment of the present invention, the compartment lids **118** are capable of sealing shut by using a snap-fit lock **120**. Snap-fit locks **120** include any sealing means that utilizes the natural elasticity of a locking piece **122** in combination with a protrusion or indentation in the base **102** or lid **104** of the golf accessory kit **100**. As depicted in FIG. 1, a locking piece **122** is located on the compartment lids **118** and a protrusion (not shown) extends from the compartment sidewalls **116** for the locking piece **122** to extend around and seal the compartment lid **118**. In other embodiments of the present invention, the compartment lids **118** may be sealed by using zippers, snaps, buttons, or the like.

[0019] In one embodiment of the present invention, the compartments **114** are transferable such that the golfer may

rearrange the compartments 114 to a design most desirable for that particular golfer. The golfer may add additional compartments 114, remove unnecessary compartments 114, or set up the compartments 114 in an order such that the golfer can structure his or her golf accessory kit 100 in accordance with his or her preference. In one embodiment, it is conceivable that the interior portion 108 of the base 102 is provided with an arrangement of small pinholes (not shown). The compartments 114 comprise pins (not shown) on their bottom surface (not shown) to line up accordingly with the pinholes in the base 102. In other embodiments of the present invention, means of making the compartments 114 transferable include utilizing Velcro, glue, magnets, or the like.

[0020] In one embodiment, the lid 104 of the golf accessory kit 100 is connected to the base 102 via a hinge 124 or several hinges such that it is freely rotatable along an edge 126. The lid 104 may be capable of sealing shut by providing a locking mechanism 128 which aligns to an indentation 130 in or a protrusion on the base 102. In one embodiment, the lid 104 may be sealed shut by using a snap-fit lock 120 or other means as discussed above with respect to the compartment lids 118. In another embodiment, the lid 104 may be freely separable from the base 102, i.e., no hinges. In this embodiment, the lid 104 may be sealed to the base 102 by providing a plurality of snap-fit locks 120 or other locking mechanism around the periphery of the lid 104.

[0021] The inner surface 106 of the lid 104 may comprise a lining 132 that may be used to store a golf glove (not shown) or other readily accessible golf accessory. In one embodiment, the lining 132 is mesh netting. In another embodiment, the lining 132 is provided with several aeration holes 134 such that a golfer can store his or her golf glove in the lining 132 and allow it ample aeration to dry. The lining 132 is generally secured to the inner surface 106 of the lid 104 along three edges 136 and remains elastically restricted on a fourth edge 138 such that the golfer may easily access the inside of the lining 132. The lining 132 may be secured to the inner surface 106 of the lid 104 by any ordinary sealing means, including glue, staples, stitching, or the like.

[0022] FIG. 2 depicts a golf accessory kit 100 in accordance with one embodiment of the present invention. In this embodiment, the compartments 114 contained in the base 102 may be set up to store individual golf accessories in a neat and structured manner. For example, in one compartment 114, a golfer may store one or more golf balls 202. Illustratively, four balls are shown; however, the compartment may be configured to store any number of balls for example six balls. In another compartment 114, a golfer may store one or more ball markers 204. In another compartment 114, a golfer may store one or more golf tees 206. In another compartment 114, a golfer may store one or more divot-repair tools 208. By utilizing the compartments 114 in this manner, a golfer can readily determine the quantity and quality of any or all of his or her golf accessories. This benefit may warn a golfer of either running out of an accessory or missing a particular accessory prior to playing.

[0023] FIG. 3 depicts a base 102 of a golf accessory kit 100 in accordance with a second embodiment of the present invention. In one embodiment, accessory clips 302 are placed within each of the compartments 114 and correspond

to a particular accessory within that compartment 114. The accessory clips 302 temporarily lock the golf accessories in place within each compartment 114. By doing this, the golfer does not need to be concerned that his or her accessories will move around as the golf bag is being moved around. In one embodiment, the golf accessory clips 302 are made from molded plastic and use elastic and friction forces to hold an accessory in place. In other embodiments of the present invention, accessory clips 302 are made from metal, wood, or the like.

[0024] Also depicted in FIG. 3, is one embodiment of the present invention providing an open area 304 within the inner portion 108 of the base 102 that allows a golfer to store other personal items, not only golf accessories. These items may include a golfer's keys, wallet, watch, or anything else the golfer may have on his or her person which he or she does not want to carry around during the course of play. It is also conceivable to provide an additional compartment 114 or other enclosure means for these non-golf accessory items.

[0025] FIG. 4 depicts a smaller version of a golf accessory kit 100 in accordance with a third embodiment of the present invention. A smaller version of a golf accessory kit 100 may be provided such that the golfer may keep the golf accessory kit 100 in his or her pocket. In one embodiment, the golf accessory kit 100 is designed to transport a golf accessory, such as a golf ball, in a center section 402 and provides two side compartments 404, 406 for any other golf accessories, as discussed above. This may be advantageous when a golfer may need to leave his or her golf bag, e.g. on a golf cart when the golfer must walk across a fairway on a particular hole to his or her golf ball during a round of play. This situation is common during the early months of the golf season, as well as on rainy days, when most golf courses do not allow a golfer to drive the golf cart onto the fairways. It is contemplated that the variations as discussed relative to FIGS. 1-3 above may be incorporated into a smaller version of a golf accessory kit 100 as depicted in FIG. 4.

[0026] FIG. 5 depicts a golf accessory kit 100 in accordance with a fourth embodiment of the present invention. In this embodiment, an oval golf accessory kit 100 is provided. The golf accessory kit 100 may have odd-shaped compartments 502, 504 making an aesthetically pleasing golf accessory kit 100. It is also conceivable that such uniquely-shaped compartments 502, 504 provide functional benefits whereas they may be accommodating to odd-shaped or odd-sized golf accessories.

[0027] It is conceivable that one embodiment of the present invention is designed to fit on the exterior of a golf bag. To fit on the exterior of a golf bag, a golf accessory kit 100 may include a hook (not shown) on an exterior surface (not shown) of the base 102, such that it is capable of hooking around an edge of the top of a golf bag. Other means of connecting the golf accessory kit 100 to the golf bag include providing a strap (not shown) that extends around the golf bag while passing through a slot (not shown), or slotted fins (not shown), of the golf accessory kit 100.

[0028] Other conceivable embodiments of the present invention include providing clips (not shown) or other attachment features on an exterior surface (not shown) of the lid 104 such that when the golf accessory kit 100 is closed,



a golfer may readily access one or more golf accessories without having to open the golf accessory kit 100. In one embodiment, providing exterior attachments in conjunction with the novel concept of attaching the golf accessory kit 100 to the outside of a golf bag is advantageous. This embodiment serves multiple purposes by not only storing golf accessories prior to and after a round of golf, but also storing easily accessible golf accessories on the exterior of a golf bag, that the golfer may or may not need on a particular hole or in preparation for a particular swing.

[0029] While the foregoing is directed to the illustrated embodiments of the present invention, other and further embodiments of the invention may be devised without departing from the basic scope thereof, and the scope thereof is determined by the claims that follow.

We claim:

1. A golf accessory kit for structuring and storing golf accessories, comprising:

- a base;
- a lid, connected to the said base with a hinge; and
- at least one transferable compartment positioned within an interior portion of the base.

2. The golf accessory kit of claim 1 wherein the at least one transferable compartment comprises a lid.

3. The golf accessory kit of claim 2 wherein the at least one transferable compartment comprises a latch to close the lid.

4. The golf accessory kit of claim 3 wherein the latch is a snap fit lock.

5. The golf accessory kit of claim 1 wherein the at least one transferable compartment can be added or removed from the base.

6. The golf accessory kit of claim 1 wherein at least one transferable compartment is retained within the base using at least one of Velcro, glue, or magnets, or snap fit structures.

7. The golf accessory kit of claim 1 wherein the lid has an inner surface comprising a lining that is used to store a golf glove.

8. The golf accessory kit of claim 1 wherein the at least one transferable compartment is configured to retain at least one golf accessory.

9. The golf accessory kit of claim 8 wherein the at least one transferable compartment is configured to retain at least one of a golf ball, ball marker, golf tee or divot-repair tool.

10. The golf accessory kit of claim 1 wherein the at least one transferable compartment comprises a plurality of transferable compartments where each transferable compartment is designed for different type of golf accessory.

11. A golf accessory kit for structuring and storing golfer's items, comprising:

- a base;
- a lid, removeably attached to the base; and
- at least one transferable compartment positioned within an interior portion of the base.

12. The golf accessory kit of claim 11 wherein the at least one transferable compartment comprises a lid.

13. The golf accessory kit of claim 12 wherein the at least one transferable compartment comprises a latch to close the lid.

14. The golf accessory kit of claim 13 wherein the latch is a snap fit lock.

15. The golf accessory kit of claim 11 wherein the at least one transferable compartment can be added or removed from the base.

16. The golf accessory kit of claim 11 wherein at least one transferable compartment is retained within the base using at least one of Velcro, glue, or magnets, or snap fit structures.

17. The golf accessory kit of claim 11 wherein the lid has an inner surface comprising a lining that is used to store a golf glove.

18. The golf accessory kit of claim 11 wherein the at least one transferable compartment is configured to store at least one golf accessory.

19. The golf accessory kit of claim 18 wherein the at least one transferable compartment is configured to retain at least one of a golf ball, ball marker, golf tee or divot-repair tool.

20. The golf accessory kit of claim 11 wherein the at least one transferable compartment comprises a plurality of transferable compartments where each transferable compartment is designed for different type of golf accessory.

\* \* \* \* \*