

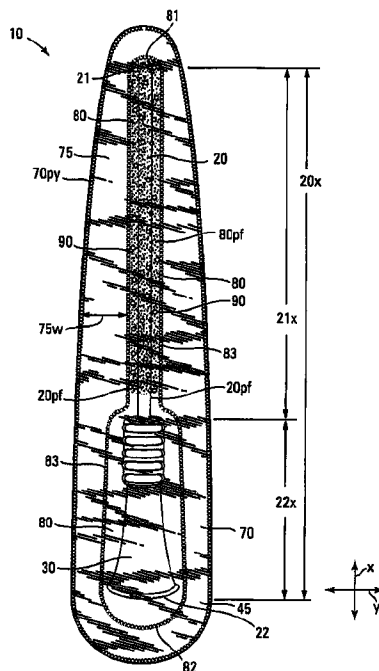

(22) Date de dépôt/Filing Date: 2020/01/08
(41) Mise à la disp. pub./Open to Public Insp.: 2020/10/16
(45) Date de délivrance/Issue Date: 2021/06/22
(30) Priorité/Priority: 2019/04/16 (US16385440)

(51) Cl.Int./Int.Cl. *A61B 50/30* (2016.01),
A61F 5/44 (2006.01), *A61J 1/00* (2006.01),
A61M 25/00 (2006.01), *B65B 31/02* (2006.01),
B65B 5/04 (2006.01)
(72) Inventeur/Inventor:
PALMER, TIMOTHY, US
(73) Propriétaire/Owner:
CURE MEDICAL, LLC, US
(74) Agent: ADE & COMPANY INC.

(54) Titre : CATHETER VESICAL INTERMITTENT PRET A UTILISER, LUBRIFIE AVEC PRECISION ET EMBALLE
(54) Title: PACKAGED PRECISION-LUBRICATED READY-TO-USE INTERMITTENT URINARY CATHETER



(57) **Abrégé/Abstract:**

A method of packaging a ready to use intermittent urinary catheter by (i) placing lubricant within a pocket formed in a base film proximate a first end of the pocket, (ii) placing a catheter within the pocket with the insertion end of the catheter proximate the first end of the pocket, (iii) partially sealing the catheter within the pocket between the base film and a cover film, (iv) pulling a vacuum within the pocket to effect controlled circumferential flow of lubricant around the insertion end portion of the catheter, and then (v) fully sealing the pocket.

ABSTRACT

A method of packaging a ready to use intermittent urinary catheter by (i) placing lubricant within a pocket formed in a base film proximate a first end of the pocket, (ii) placing a catheter within the pocket with the insertion end of the catheter proximate the first end of the pocket, (iii) partially sealing the catheter within the pocket between the base film and a cover film, (iv) pulling a vacuum within the pocket to effect controlled circumferential flow of lubricant around the insertion end portion of the catheter, and then (v) fully sealing the pocket.

PACKAGED PRECISION-LUBRICATED READY-TO-USE INTERMITTENT URINARY CATHETER

BACKGROUND

[0001] Intermittent catheters are typically used by patients suffering from urinary incontinence or by individuals unable to enjoy voluntary urination. In our highly mobile culture, the ability to have the freedom to leave home for the day or longer is an important part of life. To accommodate this need single use, pre-lubricated catheters have been developed to allow patients to perform self catheterization. An individual requiring catheterization will typically utilize several catheters each and every day. This results in the usage of a large number of catheters over time, driving a demand for inexpensive catheters without sacrificing safety and comfort.

[0002] The high daily utilization rate for intermittent urinary catheters also results in the need for individuals requiring catheterization to transport several catheters with them whenever they leave the house for any extended period of time. Packaged catheters tend to be large and bulky, rendering it difficult to discretely transport a supply of catheters.

[0003] Accordingly, a need exists for an inexpensive and efficiently packaged intermittent urinary catheter, particularly one that is self-contained and ready for use immediately upon removal from the packaging.

[0004] A particular complication encountered with the production and transport of inexpensive, single use, pre-lubricated, ready for use catheters for self-catheterization is constraining the lubricant to the insertion portion of the packaged catheter so as to prevent lubrication of the fixture end portion of the catheter which must be gripped during insertion and removal of the catheter.

[0005] Accordingly, a particular need exists for an inexpensive method for packaging a single use, pre-lubricated, ready for use catheter for self-catheterization that constrains the lubricant to contact with the insertion portion of the packaged catheter during packaging, and results in a packaged catheter that restrains migration of the lubricant within the package into contact with the fixture end of the catheter under normal storage and transport conditions.

SUMMARY OF THE INVENTION

[0006] A first aspect of the invention is an efficiently packaged, ready to use intermittent urinary catheter. The packaged catheter includes, and except for appropriate labeling and marking preferably only includes, (i) an intermittent urinary catheter, (ii) packaging formed from first and second layers of film, and (iii) a lubricant. The catheter has a longitudinal axial length, an insertion end, a funnel end and a top view profile, and is hermetically packaged between the first and second layers of film within a retention chamber formed from the films. The retention chamber has a top view profile conforming to the top view profile of the catheter and retains a supply of lubricant. In an alternative embodiment, the lubricant is predominately retained within an enlarged lubricant retaining compartment formed in the retention chamber intermediate the insertion and funnel ends of the catheter.

[0007] A second aspect of the invention is a method of efficiently packaging a precision lubricated ready to use intermittent urinary catheter having an insertion end, an insertion end length, a fixture end, and a fixture end length. The method includes the steps of (a) obtaining a base film having a pocket with a first end and a second end, wherein the pocket is configured to retain the intermittent urinary catheter with the insertion end proximate the first end and the fixture end proximate the second end, (b) injecting a limited amount of lubricant into the pocket proximate the first end of the pocket so as to form a lubricant containing pocket, (c) placing the intermittent urinary catheter into the lubricant containing pocket so as to form a catheter containing pocket, with the insertion end of the intermittent urinary catheter proximate the first end and the fixture end of the intermittent urinary catheter proximate the second end, (d) sealing a cover film to the base film with an unsealed opening proximate the second end of the pocket so as to form an enclosed catheter containing retention chamber accessible through the opening, (e) drawing a vacuum on the enclosed catheter containing retention chamber through the opening sufficient to compress the retention chamber and cause lubricant to circumferentially flow around and coat a portion of the exterior surface area of the insertion end length of the catheter within the retention chamber without reaching and coating the fixture end length of the catheter within the retention chamber, and thereafter (f) sealing the opening so as to form a hermetically packaged intermittent urinary catheter having a circumferentially lubricated insertion end length and a lubricant-free fixture end length.

According to another aspect of the invention, there is provided a method of hermetically packaging an intermittent urinary catheter having an insertion end, an insertion end length defining an exterior surface area, a fixture end, and a fixture end length, comprising the steps of:

- (a) obtaining a base film having a pocket with a first end and a second end, wherein the pocket is configured to retain the intermittent urinary catheter with the insertion end proximate the first end and the fixture end proximate the second end,
- (b) injecting a limited amount of lubricant into the pocket proximate the first end of the pocket so as to form a lubricant containing pocket,
- (c) placing the intermittent urinary catheter into the lubricant containing pocket so as to form a catheter containing pocket, with the insertion end of the intermittent urinary catheter proximate the first end and the fixture end of the intermittent urinary catheter proximate the second end,
- (d) sealing a cover film to the base film with an unsealed opening proximate the second end of the pocket so as to form an enclosed catheter containing retention chamber accessible through the opening,
- (e) drawing a vacuum on the enclosed catheter containing retention chamber through the opening sufficient to compress the retention chamber and cause lubricant to circumferentially flow around and coat a portion of the exterior surface area of the insertion end length of the catheter within the retention chamber without reaching and coating the fixture end length of the catheter within the retention chamber, and thereafter
- (f) sealing the opening so as to form a hermetically packaged intermittent urinary catheter having a circumferentially lubricated insertion end length and a lubricant-free fixture end length.

BRIEF DESCRIPTION OF THE DRAWINGS

[0008] Figure 1 is a top view of one embodiment of the invention.

[0009] Figure 2 is a top view of another embodiment of the invention

- [0010]** Figure 3 is a side view of the invention depicted in Figure 2.
- [0011]** Figure 4 is an enlarged cross-sectional side view of a portion of the invention depicted in Figures 2 and 3 taken along line 4-4.
- [0012]** Figure 5 is a perspective view of one embodiment of a base layer and a cover layer suitable for use in hermetically packaging an intermittent urinary catheter in accordance with the invention.
- [0013]** Figure 6 is a perspective view of the base layer depicted in Figure 5 after injection of lubricant into the pocket of the base layer in accordance with the invention.
- [0014]** Figure 7 is a side view of the base layer depicted in Figure 6 after placement of a catheter into the lubricant containing pocket of the base layer and heat sealing of the cover layer to the base layer, but prior to pulling of a vacuum in accordance with the invention.
- [0015]** Figure 8 is a side view of the invention depicted in Figure 7 after pulling of a vacuum and complete sealing of the catheter within the packaging in accordance with the invention.

DETAILED DESCRIPTION OF A PREFERRED EMBODIMENT

Nomenclature

- 10** Packaged Intermittent Urinary Catheter
- 20** Catheter
- 20Pr** Top View Profile of Catheter
- 20x** Axial Length of Catheter
- 21** Insertion End of Catheter
- 21x** Axial Length of Insertion End Portion of Catheter
- 22** Fixture End or Funnel End of Catheter
- 22x** Axial Length of Fixture End Portion of Catheter
- 25x** Pre-vacuum Axial Length of Catheter In Contact with Lubricant Within the Pocket
(Alpha Length)
- 30** Fixture or Funnel
- 40** Base Layer of Packaging

- 50** Pocket in Base Layer of Packaging
- 50Pr** Top View Profile of Pocket
- 51** First End of Pocket
- 52** Second End of Pocket
- 60** Cover Layer of Packaging
- 70** Packaging
- 70Py** Peripheral Edge of Packaging
- 75** Margins of Packaging
- 75w** Width of Margins
- 80** Retention Chamber
- 80Pr** Top View Profile of Retention Chamber
- 80Py** Periphery of Retention Chamber
- 80Lube** Lubricant Containing Compartment
- 80Neck** Metering Neck Area of Retention Chamber
- 81** First End of Retention Chamber
- 82** Second End of Retention Chamber
- 83** Sides of Retention Chamber
- 90** Lubricant
- x** Longitudinal or Axial Direction
- y** Lateral (Radial) Direction
- z** Transverse (Radial) Direction

Definitions

[0016] As utilized herein, including the claims, the term “*fixture*” means and refers to the well known commercially available components commonly attached to the proximal non-insertion end of urinary catheters, including specifically but not exclusively funnels, luer locks, clamps, valves, etc.

[0017] As utilized herein, including the claims, the term “*predominant*” means at least 80%.

Description

PACKAGED CATHETER

[0018] The invention is an efficiently packaged, ready to use intermittent urinary catheter **10**. Referring to Figures 1-3, the packaged catheter **10** includes, and in a preferred embodiment only includes the functional components of, (i) an intermittent urinary catheter **20** equipped with a fixture **30** at one end, (ii) packaging **70** formed from a base layer **40** and cover layer **60** of film, and (iii) a lubricant **90**.

[0019] The catheter **20** has an axial length **20x** with an insertion end **21**, an insertion end axial length portion **21x**, a fixture end **22**, and a fixture end axial length portion **22x**. The catheter **20** defines a top view profile **20Pr**. The packaging **70** may be used with substantially any commercially available catheter **20**, but is particularly suited for use with shorter female urinary catheters.

[0020] The catheter **20** is hermetically packaged within a retention chamber **80** formed between base layer **40** and cover layer **60** films sealed together, preferably by heat seal, within a peripheral margin **75** of the packaging **70**. The films **40** and **60** may have originated from separate and independent rolls or sheets of film, or they may have been formed by simply folding a single length of film back upon itself. The packaging **70** formed by the base layer **40** and cover layer **60** films defines an outer peripheral edge **70Py**. The retention chamber **80** has a periphery **80Py** defining a top view profile **80Pr** that generally conforms to the top view profile **20Pr** of the catheter **20**, except for an optional enlarged compartment **80Lube** intermediate the insertion **21** and funnel **22** ends of the catheter **20** in which lubricant **90** can be stored for coating the catheter **20** when it is withdrawn from the packaging **70** for use. The optional enlarged compartment **80Lube** is preferably axially aligned with the balance of the retention chamber **80** such that the catheter **20** passes through the enlarged compartment **80Lube**.

[0021] Referring to Figures 1 and 2, the margins **75** have a preferred width **75w** of between 0.2 and 5 cm, most preferred between about 0.3 and 2 cm, around the entire periphery of the retention chamber **80**.

[0022] The packaging layers **40** and **60** may be constructed from the same or different films, with the films selected from materials that are impervious to the lubricant **90**, and suitable

for hermetically sealing the catheter 20 within a retention chamber 80 formed from the films 40 and 60. Suitable materials include specifically but not exclusively, films of polyester, polyethylene, polypropylene, Surlyn®, Tyvek®, aluminum, Mylar®, etc.

[0023] Referring to Figures 1 and 2, the retention chamber 80 has a top view profile 80_{pr} that tightly matches the top view profile 20_{pr} of the catheter 20 along a predominant portion of the axial length 20_x of the catheter 20 for purposes of maintaining lubricant 90 retained within the retention chamber 80 in close proximity to the catheter 20 so that the lubricant 90 will adhere to and coat the insertion end portion 21_x of the catheter 20 as the catheter 20 is withdrawn from the packaging 70. The profiles are preferably matched such that the axial cross-sectional area of the retention chamber 80 (*i.e.*, the cross-sectional area of the retention chamber 80 in a plane extending in the lateral y and transverse z directions and perpendicular to the longitudinal x axis of the catheter 20) is between 1.2 and 1.8 times the corresponding axial cross-sectional area of the catheter 20 along at least 50%, preferably along at least 80% and preferably along at least 90% of the axial length of the insertion end portion 21_x of the catheter 20.

[0024] Referring to Figure 2, when the retention chamber 80 includes an expanded lubricant containing compartment 80_{Lube}, the axial cross-sectional area of the lubricant containing compartment 80_{Lube} is between 2 and 4 times the largest axial cross-sectional area of the catheter 20 lying within the compartment 80_{Lube} as packaged. The lubricant containing compartment 80_{Lube} necks down at the longitudinal x end of the compartment 80_{Lube} proximate the fixture end 22 of the catheter 20, preferably necking down at both longitudinal x ends, to an axial cross-sectional area that is between 1.2 and 1.8 times the largest axial cross-sectional area of the catheter 20 lying within the compartment 80_{Lube} as packaged. This necked down area 80_{Neck} formed from the packaging films 40 and 60, serves to meter the coating of lubricant 90 on the catheter 20 as the catheter 20 is withdrawn from the packaging 70 for use.

METHOD OF PACKAGING READY TO USE CATHETER

[0025] A preferred method of packaging the ready to use intermittent urinary catheter 10 employs a novel lubricant placement and spreading technique.

[0026] Referring to Figure 5, the method employs a base film 40, a cover film 60 and lubricant 90.

[0027] The base film **40** has a blister or pocket **50** with a first end **51** and a second end **52**. The pocket **50** preferably has a top view profile **50_{Pr}** conforming to the top view profile **20_{Pr}** of the intermittent urinary catheter **20**, and is configured to retain at least a portion and preferably the entire urinary catheter **20** within the pocket **50**, with the insertion end **21** of the catheter **20** proximate the first end **51** of the pocket **50** and the fixture end **22** of the catheter **20** proximate the second end **52** of the pocket.

[0028] The cover film **60** is preferably a planar sheet.

[0029] Referring to Figure 6, an amount of lubricant **90** is inserted into the pocket **50** in the base film **40** along a substantial axial length **x** of the insertion end portion **21x** of the pocket **50** so as to form a lubricant containing pocket **50**. The lubricant **90** is preferably applied so as to extend along at least about 30% of the axial length of the insertion end portion **21x** of catheter **20**, with a preference for a continuously applied axial **x** length of at least 50% of the axial length of the insertion end portion **21x**, more preferably at least 70% and most preferably at least 80%.

[0030] Referring to Figure 7, a urinary catheter **20** is then placed into the lubricant containing pocket **50** with an alpha axial length **25x** of the insertion end portion **21x** resting atop and in fluid communication with the lubricant **90** so as to form a catheter containing pocket **50**, with the insertion end **21** of the urinary catheter **20** proximate the first end **51** of the pocket **50** and the fixture end **22** of the urinary catheter **20** proximate the second end **52** of the pocket **50**. The alpha axial length **25x** of the insertion end portion **21x** resting atop and in fluid communication with the lubricant **90** is preferably between 30% and 90% of the insertion end length of the catheter, more preferably between 50% and 80% and most preferably 40% and 60%.

[0031] The cover film **60** is placed over the base film **40** and sealed, such as by heat sealing, to the base film **40** around the profile of the pocket **50_{Pr}** except along a length proximate the second end **52** of the pocket **50** so as to form a catheter containing retention chamber **80** between the base film **40** and the cover film **60** which is sealed except for an opening proximate the second end **82**.

[0032] Referring to Figure 8, a vacuum is drawn on the catheter containing retention chamber **80** through the opening sufficient to compress the retention chamber **80** and thereby cause lubricant **90** to circumferentially flow around and coat a substantial percentage of the

surface area of the alpha axial length 25x of the insertion end portion 21x resting atop and in fluid communication with the lubricant 90, with a preference for coating at least 70% of the surface area of the alpha axial length 25x and most preferably 90%.

[0033] Pulling of a vacuum with resultant compression of the retention chamber 80 will also tend to draw lubricant 90 an axial distance x towards the second end 52 of the pocket 50. The vacuum should be applied at a pressure and for a duration sufficient to effect substantially complete circumferential coating of that portion of the insertion end portion 21x of the catheter 20 placed atop the lubricant 90, but without causing the lubricant 90 to travel an axial distance x that results in coating any portion of the fixture end 22 of the catheter 20.

[0034] The lubricant 90 preferably has a viscosity of between about 15,000 and about 500,000 centipoise at 72°F. When the viscosity is less than about 15,000 cp it is difficult to control the axial x length of the insertion end portion 21x of catheter 20 which is coated with lubricant 90 when pulling the vacuum, along with an increased likelihood that lubricant 90 will migrate into contact with the fixture end portion 22x of the catheter 20 under normal storage and transport conditions. Generally, when a high lubricity embodiment is desired the lubricant 90 preferably has a viscosity of between 15,000 and 50,000 centipoise at 72°F, and when superior control over lubricant 90 coverage during packaging and lubricant 90 migration during normal storage and handling is desired the lubricant 90 preferably has a viscosity of between 100,000 and 400,000 centipoise at 72°F.

[0035] The opening into the retention chamber 80 is then sealed, such as by heat sealing, to form a hermetically packaged intermittent urinary catheter 10 having a lubricated insertion end portion 21x and a lubricant-free fixture end portion 22x. The vacuum may be and preferably is at least partially released and more preferably is fully released prior to sealing of the opening.

I claim:

- 1. A method of hermetically packaging an intermittent urinary catheter having an insertion end, an insertion end length defining an exterior surface area, a fixture end, and a fixture end length, comprising the steps of:**
 - (a) obtaining a base film having a pocket with a first end and a second end, wherein the pocket is configured to retain the intermittent urinary catheter with the insertion end proximate the first end and the fixture end proximate the second end,**
 - (b) injecting a limited amount of lubricant into the pocket proximate the first end of the pocket so as to form a lubricant containing pocket,**
 - (c) placing the intermittent urinary catheter into the lubricant containing pocket so as to form a catheter containing pocket, with the insertion end of the intermittent urinary catheter proximate the first end and the fixture end of the intermittent urinary catheter proximate the second end,**
 - (d) sealing a cover film to the base film with an unsealed opening proximate the second end of the pocket so as to form an enclosed catheter containing retention chamber accessible through the opening,**
 - (e) drawing a vacuum on the enclosed catheter containing retention chamber through the opening sufficient to compress the retention chamber and cause lubricant to circumferentially flow around and coat a portion of the exterior surface area of the insertion end length of the catheter within the retention chamber without reaching and coating the fixture end length of the catheter within the retention chamber, and thereafter**
 - (f) sealing the opening so as to form a hermetically packaged intermittent urinary catheter having a circumferentially lubricated insertion end length and a lubricant-free fixture end length.**

- 2. The method of claim 1 wherein the intermittent urinary catheter has a profile and the pocket has a profile conforming to the profile of the intermittent urinary catheter.**

- 3. The method of claim 1 wherein an alpha length of the intermittent urinary catheter is placed atop and into fluid contact with the lubricant within the pocket in step (c) and the vacuum is sufficient to effect a circumferential flow of lubricant around the alpha length so as to coat at least 70% of the external surface area of the alpha length of the catheter.**
- 4. The method of claim 3 wherein the vacuum is sufficient to effect a circumferential flow of lubricant around the alpha length so as to coat at least 90% of the external surface area of the alpha length of the catheter.**
- 5. The method of claim 3 wherein the alpha length is between 30% and 90% of the insertion end length of the catheter.**
- 6. The method of claim 3 wherein the alpha length is between 50% and 80% of the insertion end length of the catheter.**
- 7. The method of claim 3 wherein the alpha length is between 40% and 60% of the insertion end length of the catheter.**
- 8. The method of claim 1 wherein the lubricant has a viscosity of between 15,000 and 500,000 centipoise at 72°F.**
- 9. The method of claim 1 wherein the lubricant has a viscosity of between 15,000 and 50,000 centipoise at 72°F.**
- 10. The method of claim 1 wherein the lubricant has a viscosity of between 100,000 and 400,000 centipoise at 72°F.**
- 11. The method of claim 1 wherein the cover film is heat sealed to the base film in step (d).**
- 12. The method of claim 1 wherein the opening is heat sealed.**

13. The method of claim 1 wherein the cover film is a planar sheet.

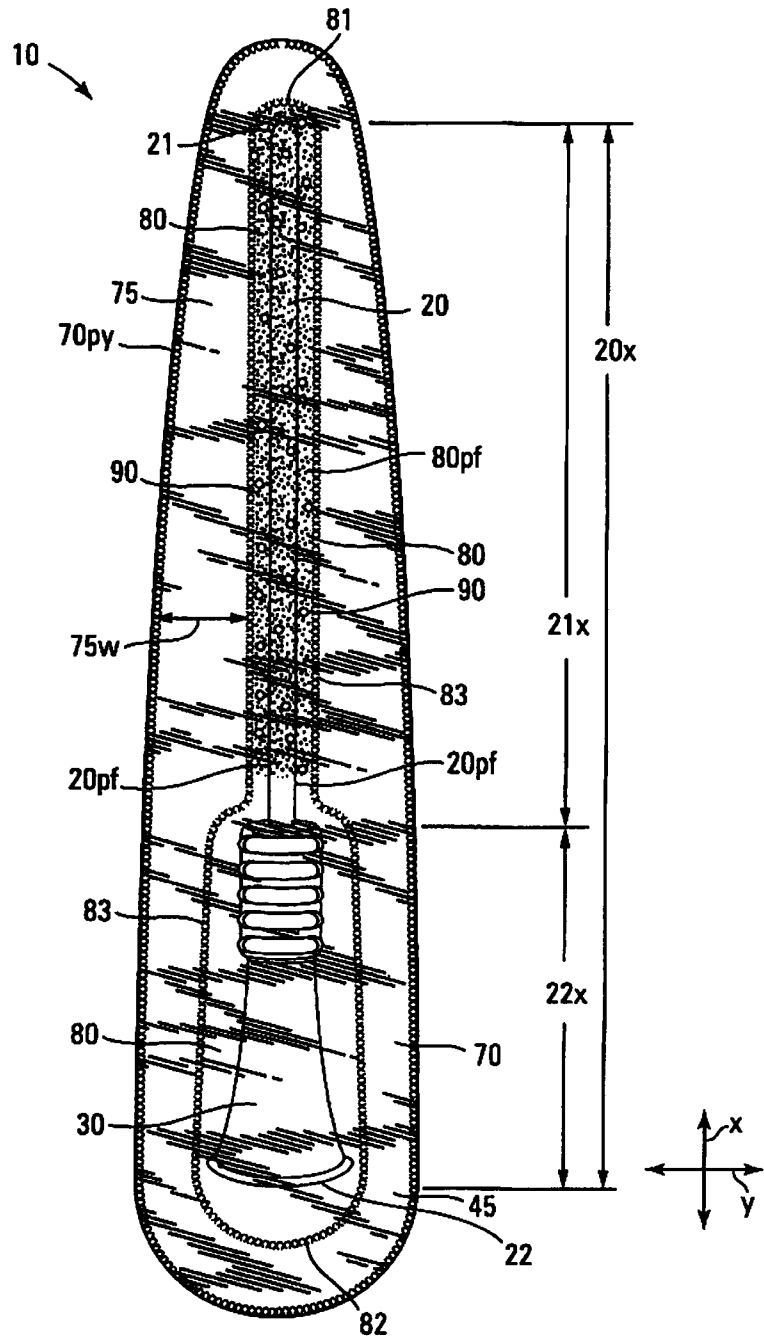

FIG. 1

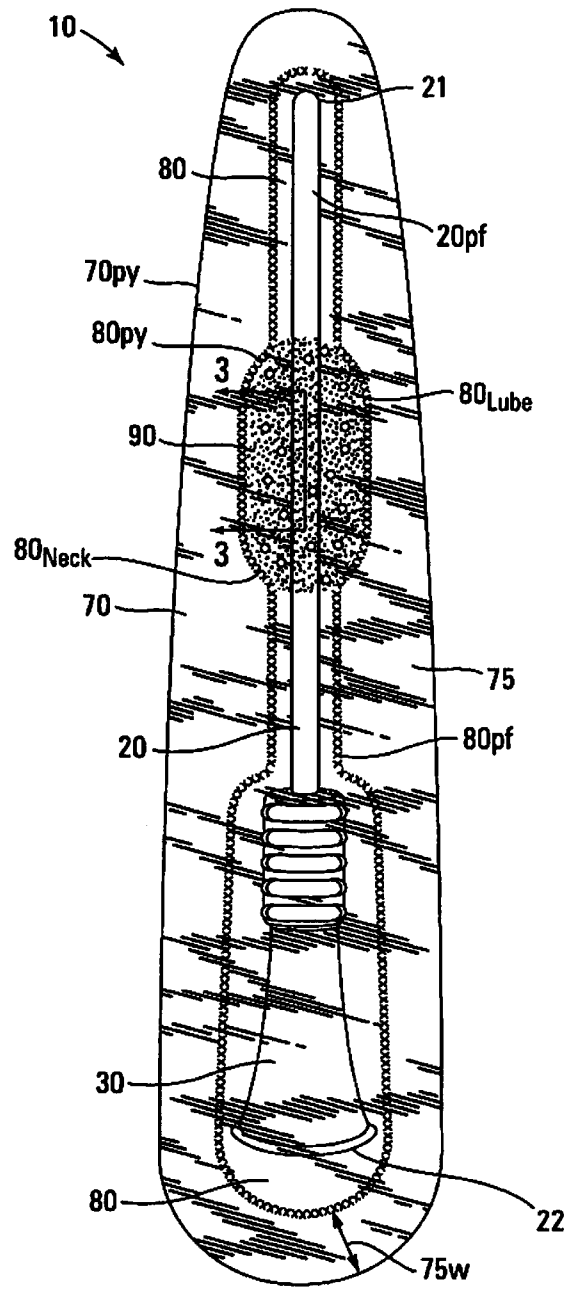

FIG. 2

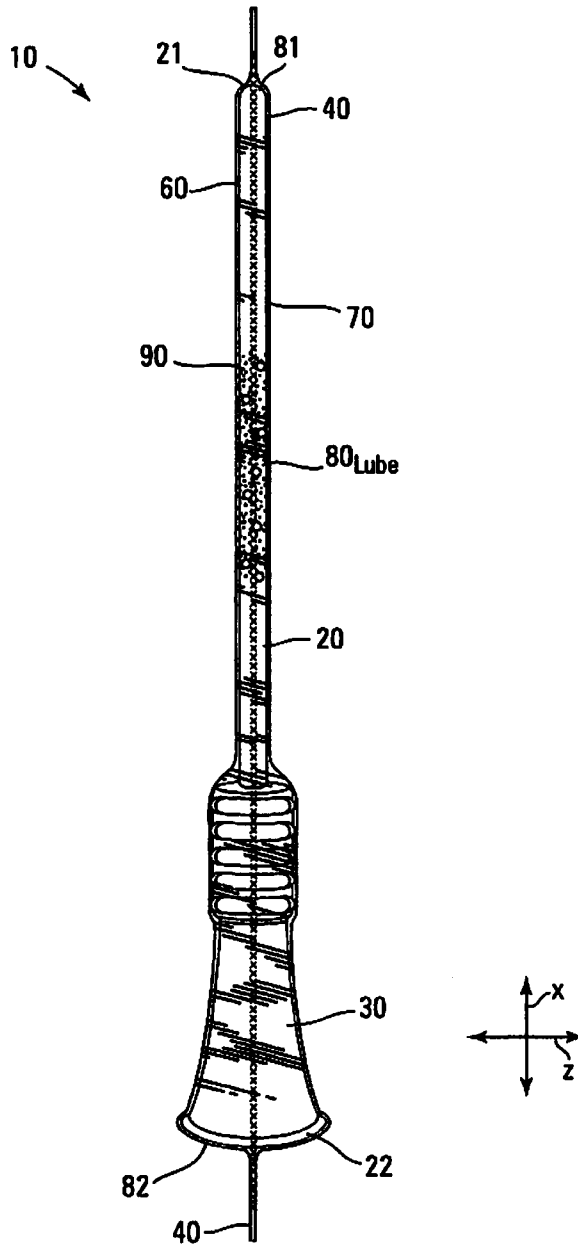

FIG. 3

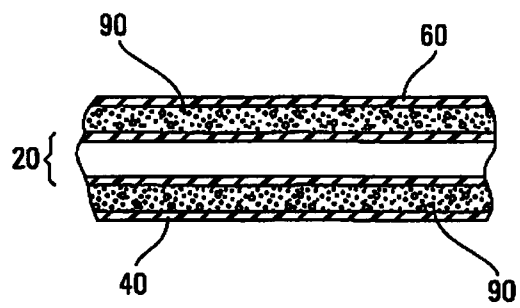

FIG. 4

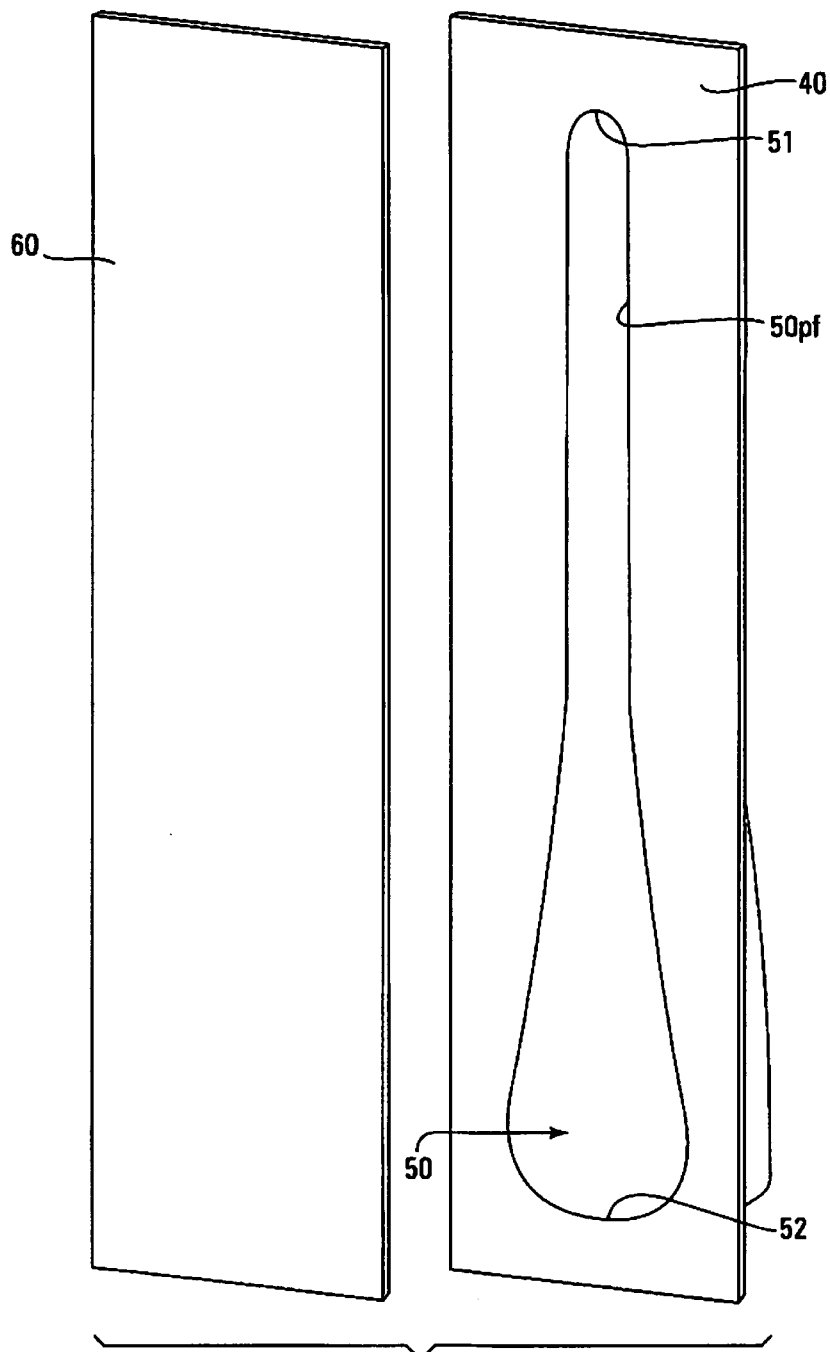

FIG. 5

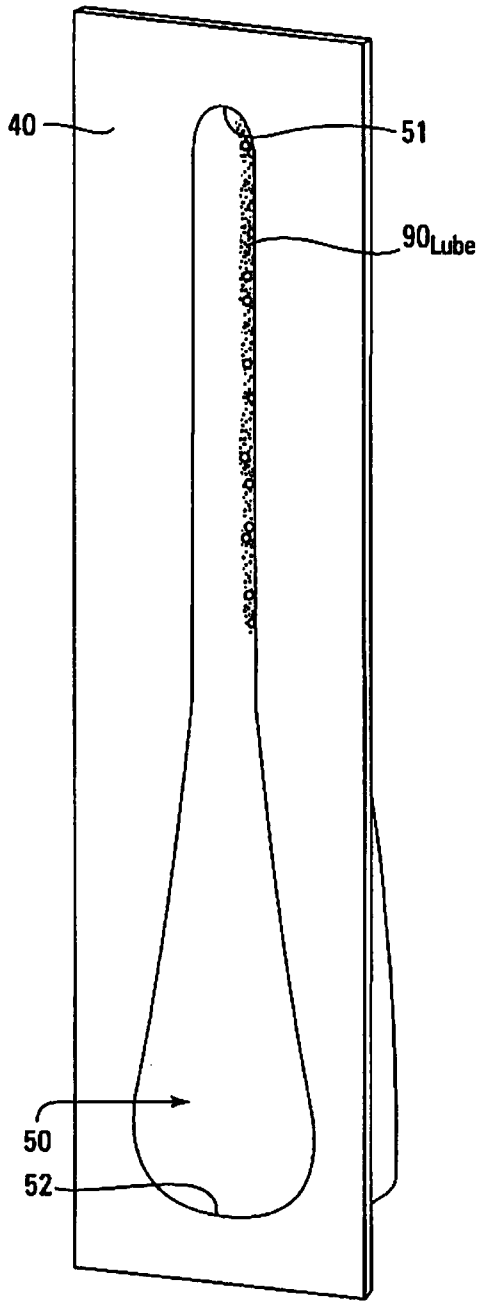

FIG. 6

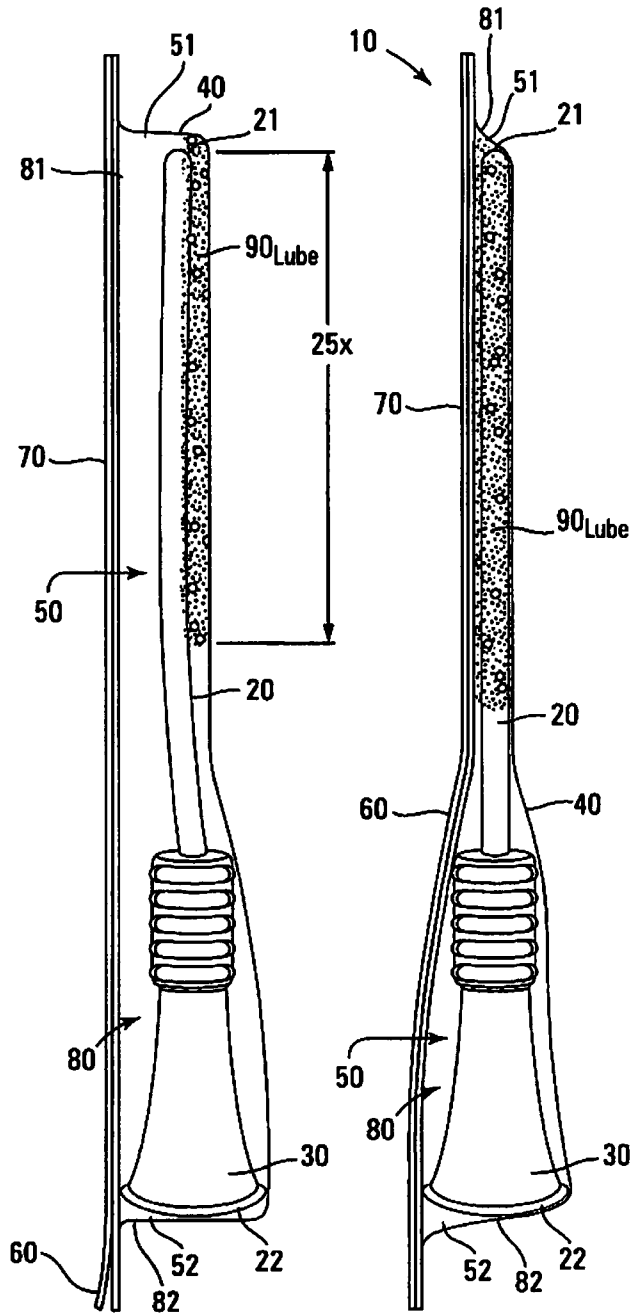

FIG. 7

FIG. 8

