

(12) **UK Patent Application** (19) **GB** (11) **2462039** (13) **A**

(43) Date of A Publication

27.01.2010

(21) Application No: **0920375.3**
(22) Date of Filing: **24.10.2008**
Date Lodged: **20.11.2009**
(30) Priority Data:
(31) **0721269** (32) **30.10.2007** (33) **GB**
(31) **0722645** (32) **19.11.2007** (33) **GB**
(31) **0722728** (32) **20.11.2007** (33) **GB**
(62) Divided from Application No **0819581.0** under Section 15(9) of the Patents Act 1977

(51) INT CL:
H03M 13/27 (2006.01) **H04L 27/26** (2006.01)
G06F 7/58 (2006.01) **H04N 7/24** (2006.01)
(56) Documents Cited:
EP 1463256 A1 **EP 1463255 A1**
(58) Field of Search:
INT CL **G06F, H03M, H04N**
Other: **EPODOC, WPI**

(71) Applicant(s):
Sony Corporation
(Incorporated in Japan)
1-7-1 Konan, Minato-ku, Tokyo 108-0075, Japan
(72) Inventor(s):
Matthew Paul Athol Taylor
Samuel Asangbeng Atungsiri
John Nicholas Wilson
(74) Agent and/or Address for Service:
D Young & Co
120 Holborn, LONDON, EC1N 2DY, United Kingdom

(54) Abstract Title: **Symbol to sub-carrier interleaver for DVB-T2 using odd interleaving**

(57) DVB-T and DVB-H interleave symbols to sub-carriers using a pseudo random sequence generated using an LFSR (linear feedback shift register) 200 whose bits are fed through a permutation matrix 210 to generate the read address for a partitioned interleaver memory. The invention provides improved separation between symbols by using an odd interleaving process only (fig 9) for successive sets of data symbols, when the number of data symbols which can be carried per OFDM symbol is less than half the maximum that can be carried. Data symbols to be transmitted are sequentially written into the memory and read out using generated address. Applying a cyclic offset to the address that changes from symbol to symbol reduces the likelihood that successive data bits which are close in order are mapped onto the same sub-carrier of an OFDM symbol.

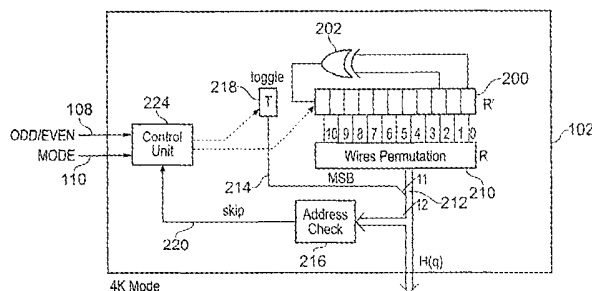

FIG. 5

GB 2462039 A

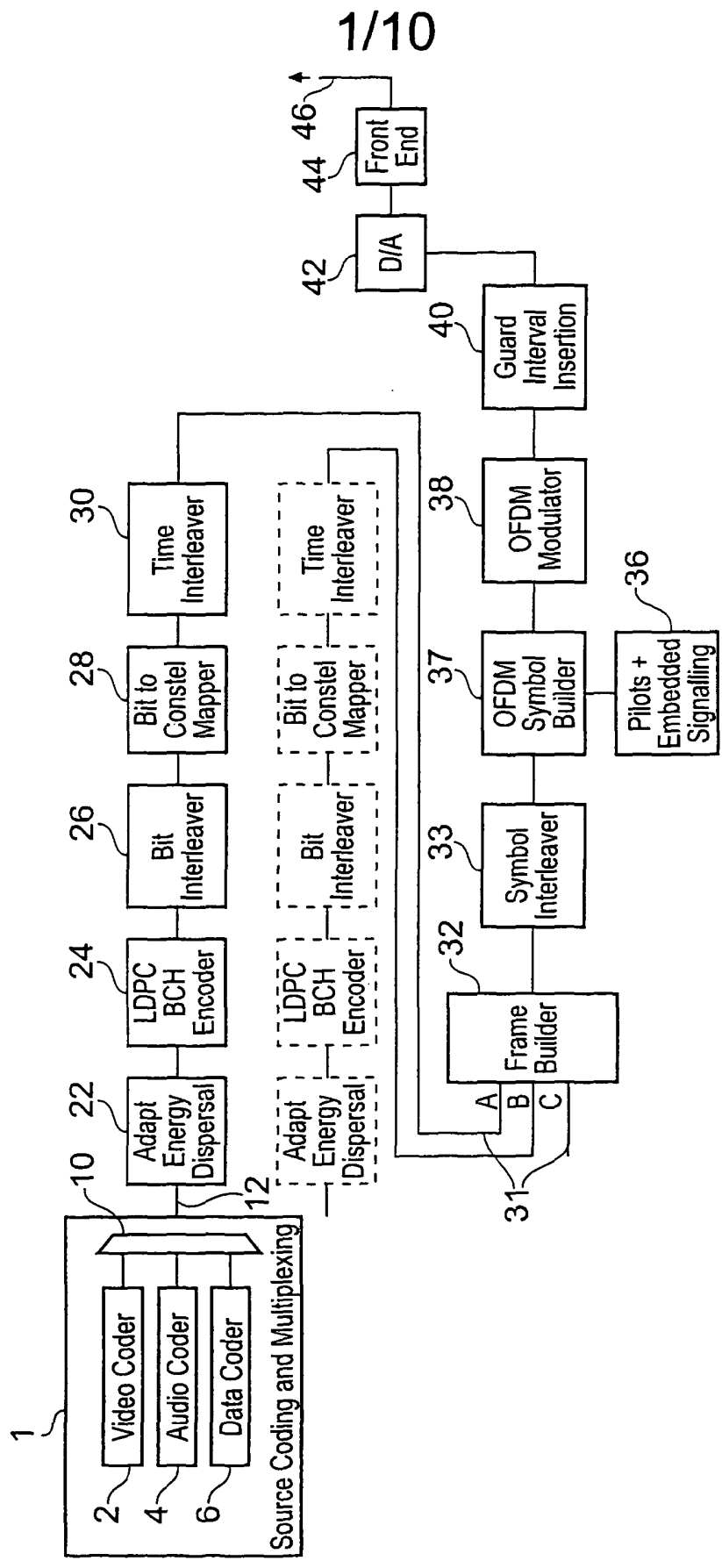

FIG. 1

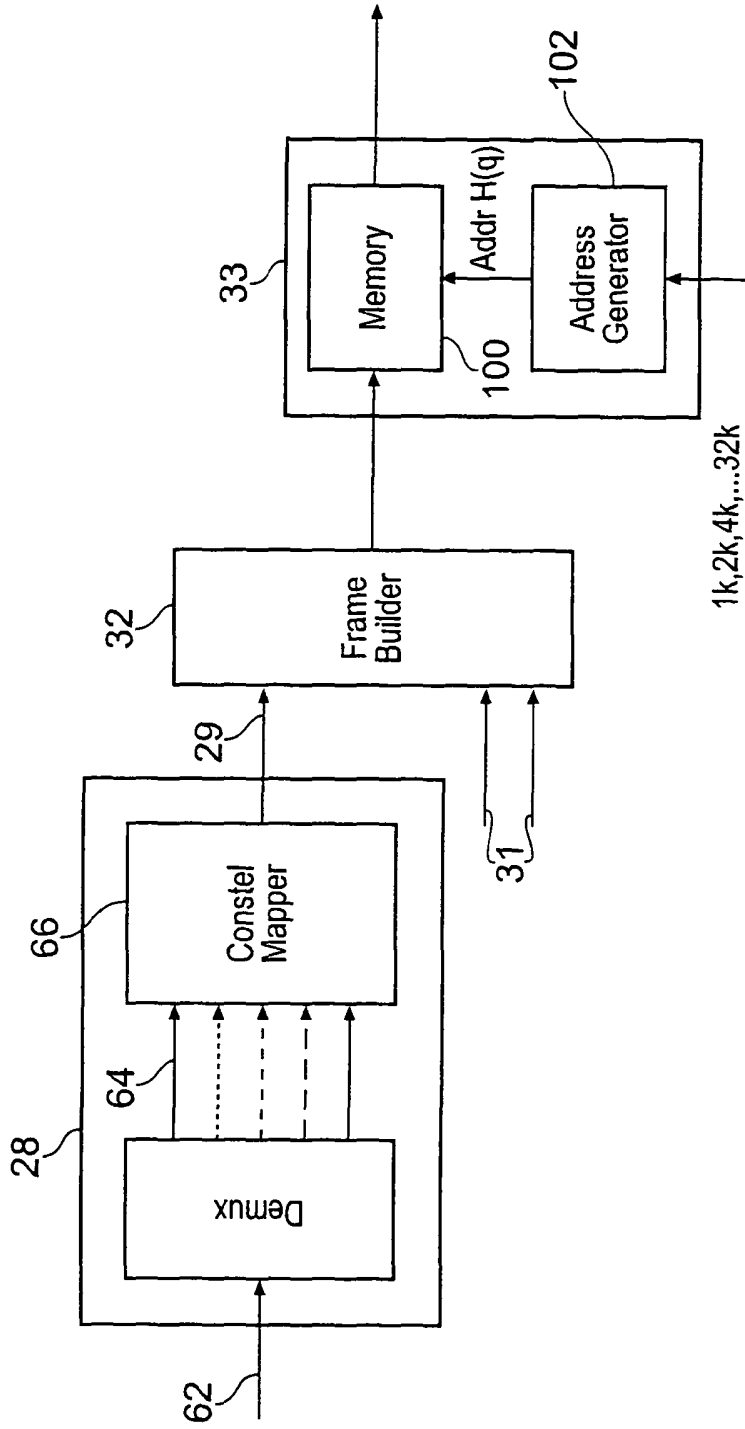

FIG. 2

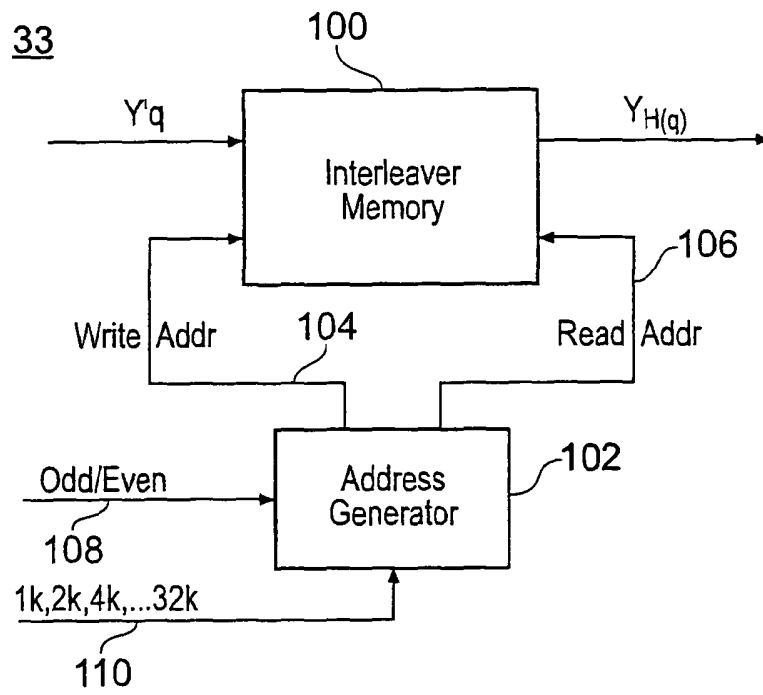

FIG. 3

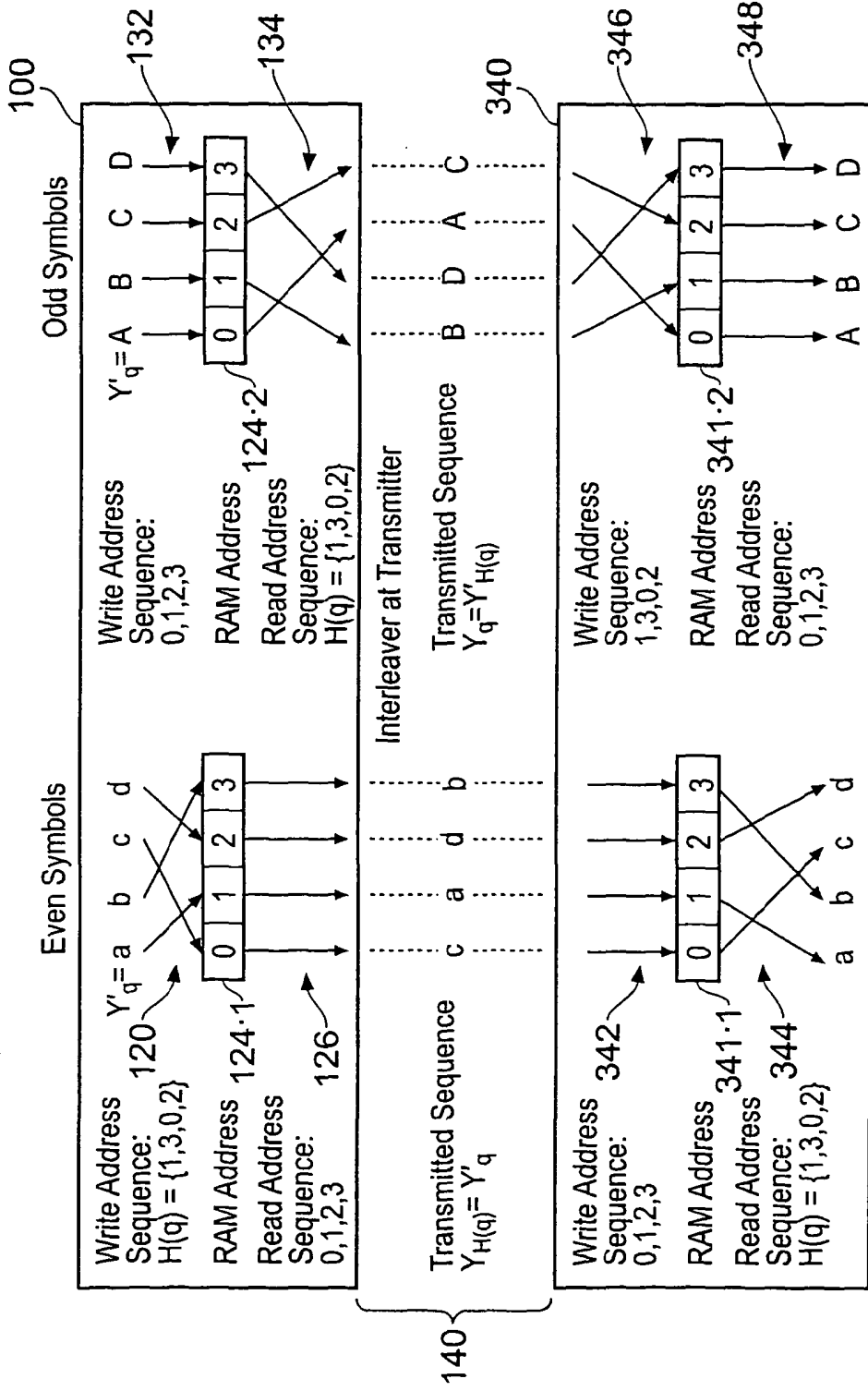

FIG. 4

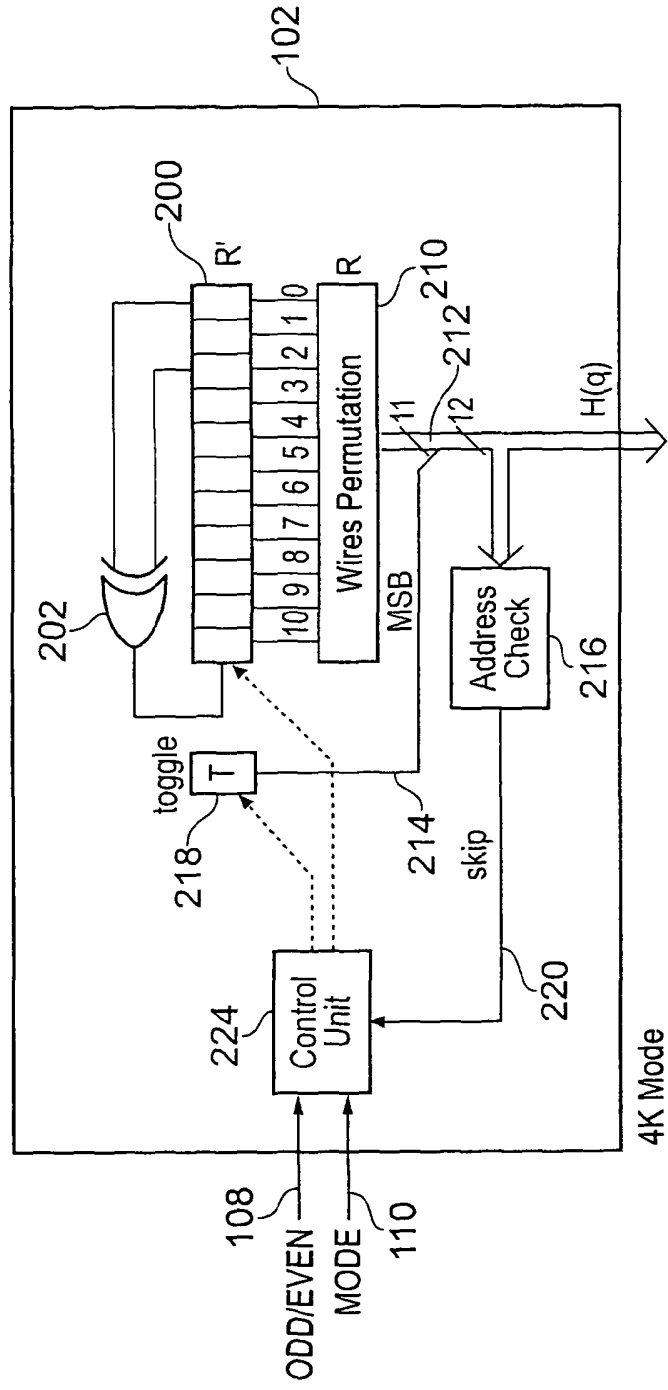

FIG. 5

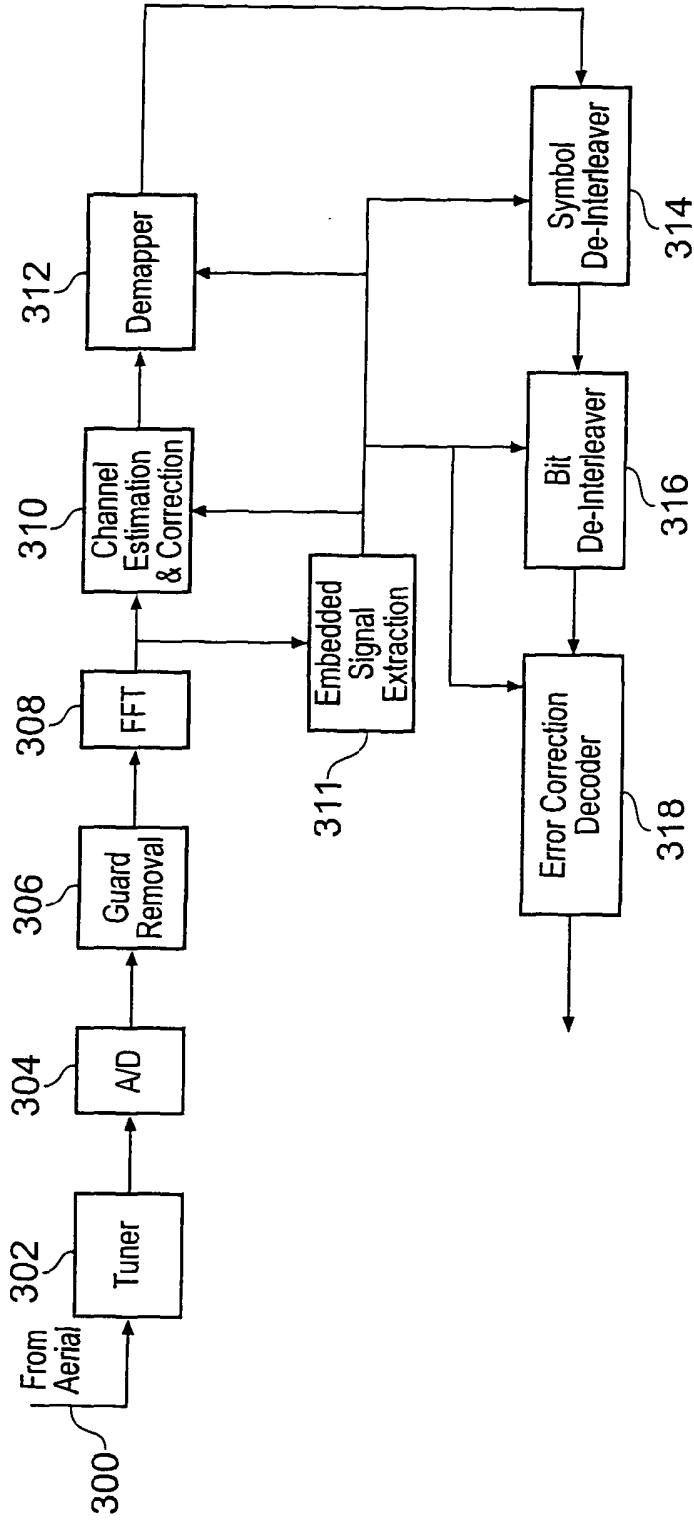

FIG. 6

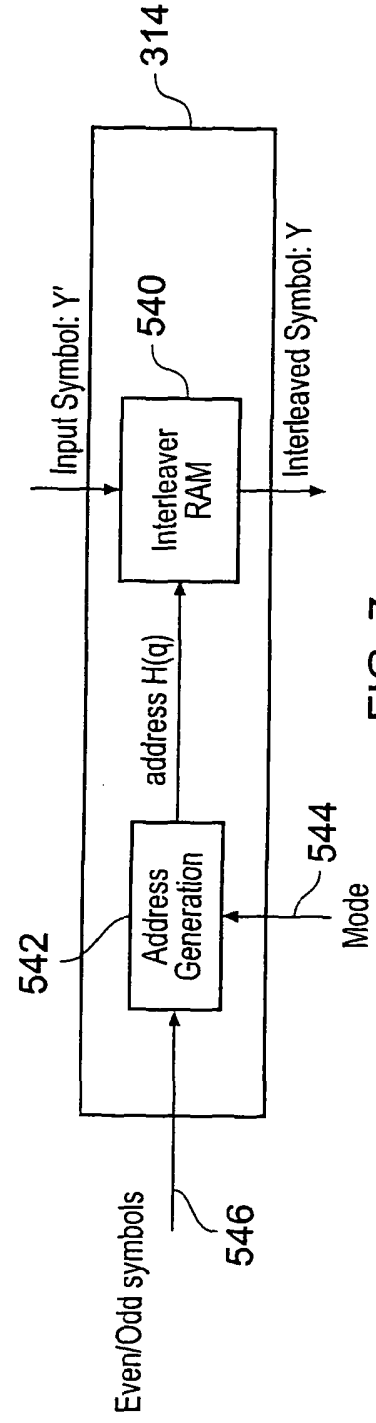

FIG. 7

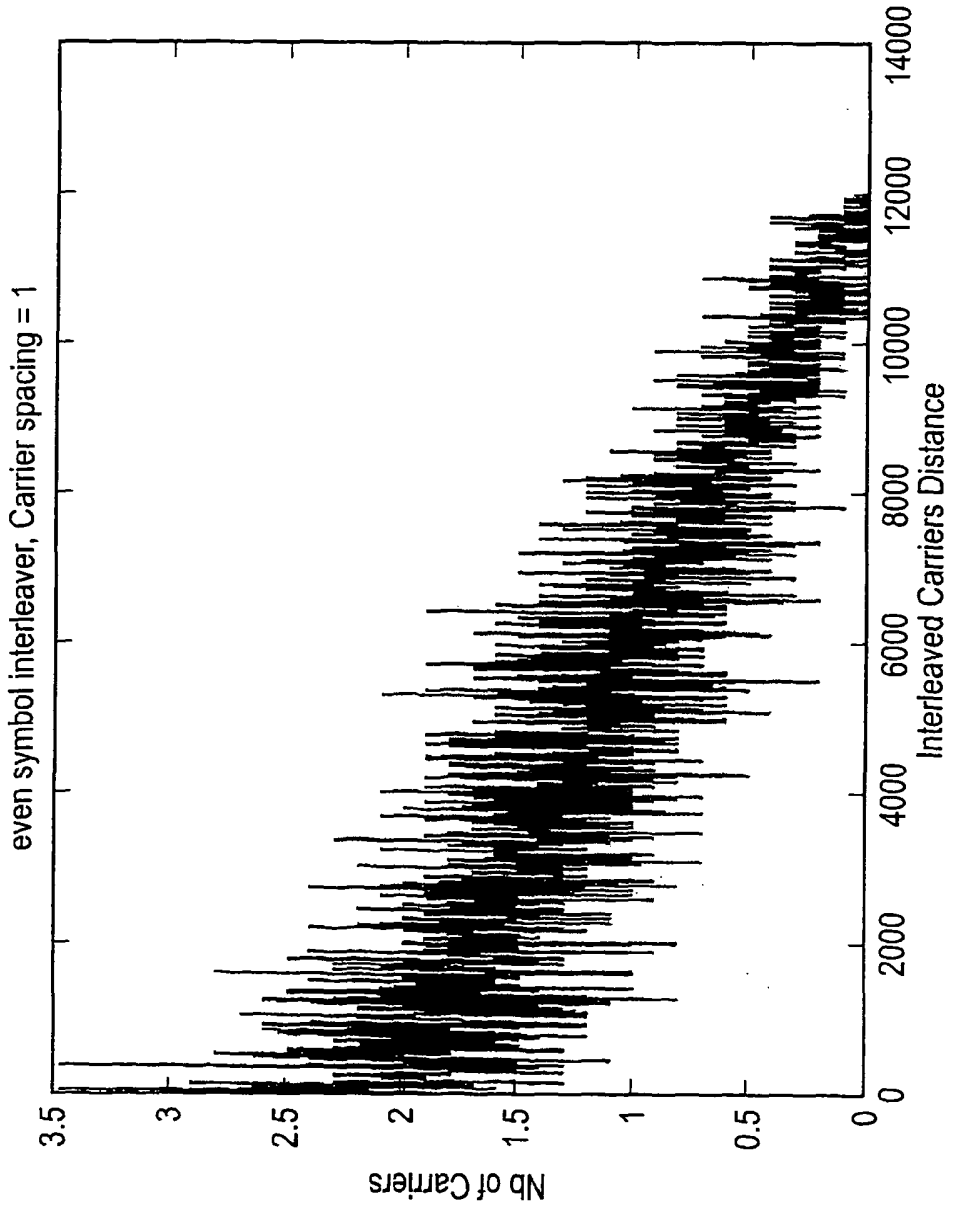

FIG. 8(a)

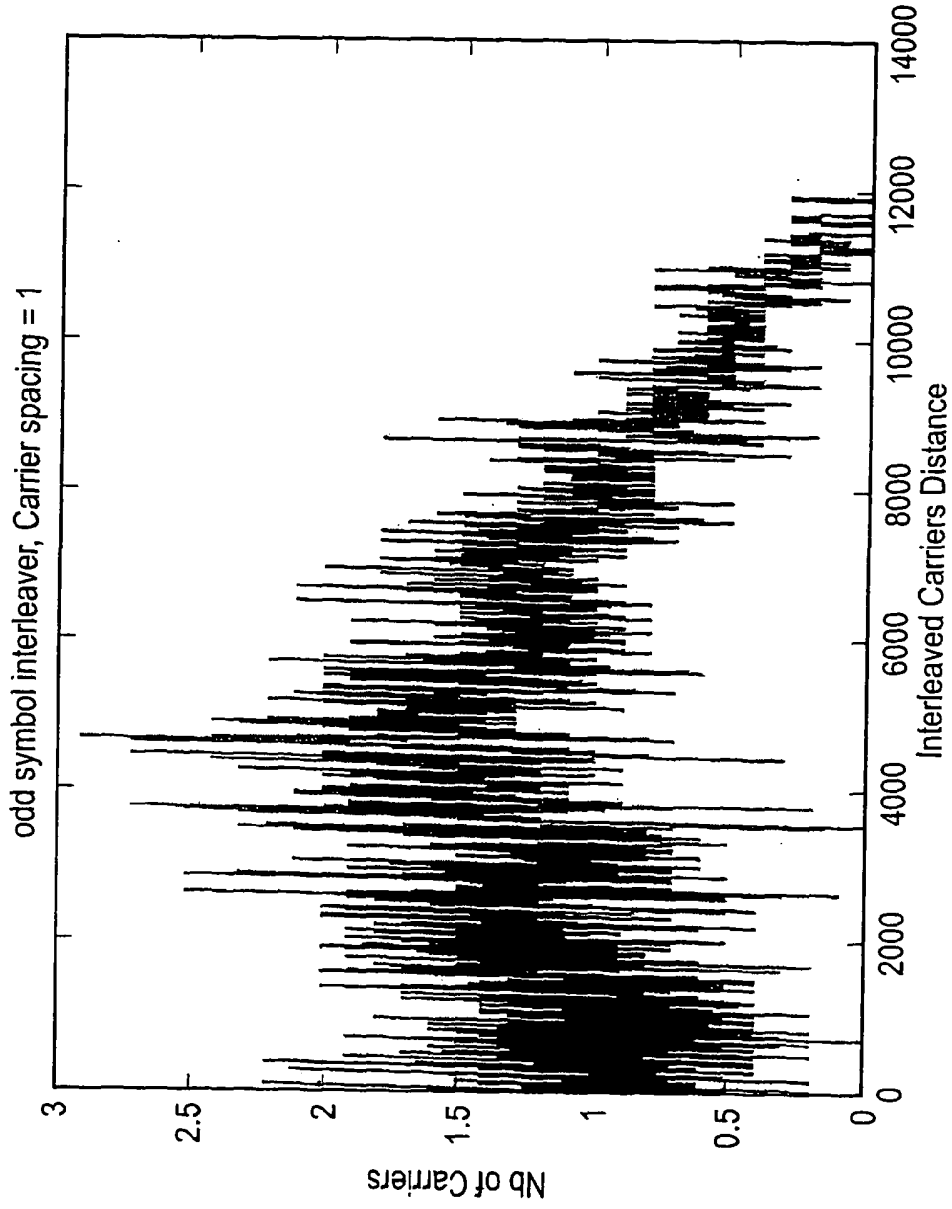

FIG. 8(b)

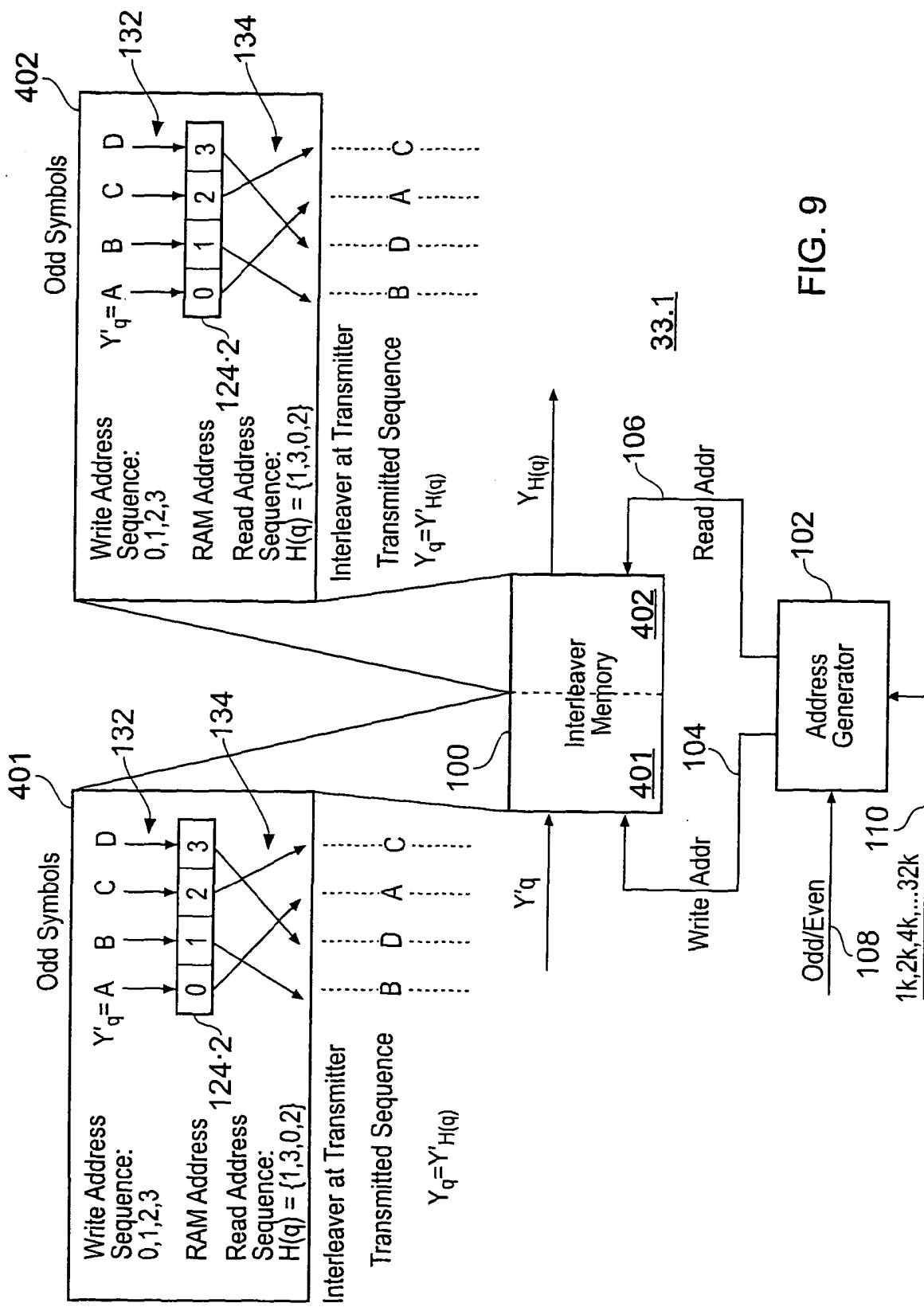

FIG. 9

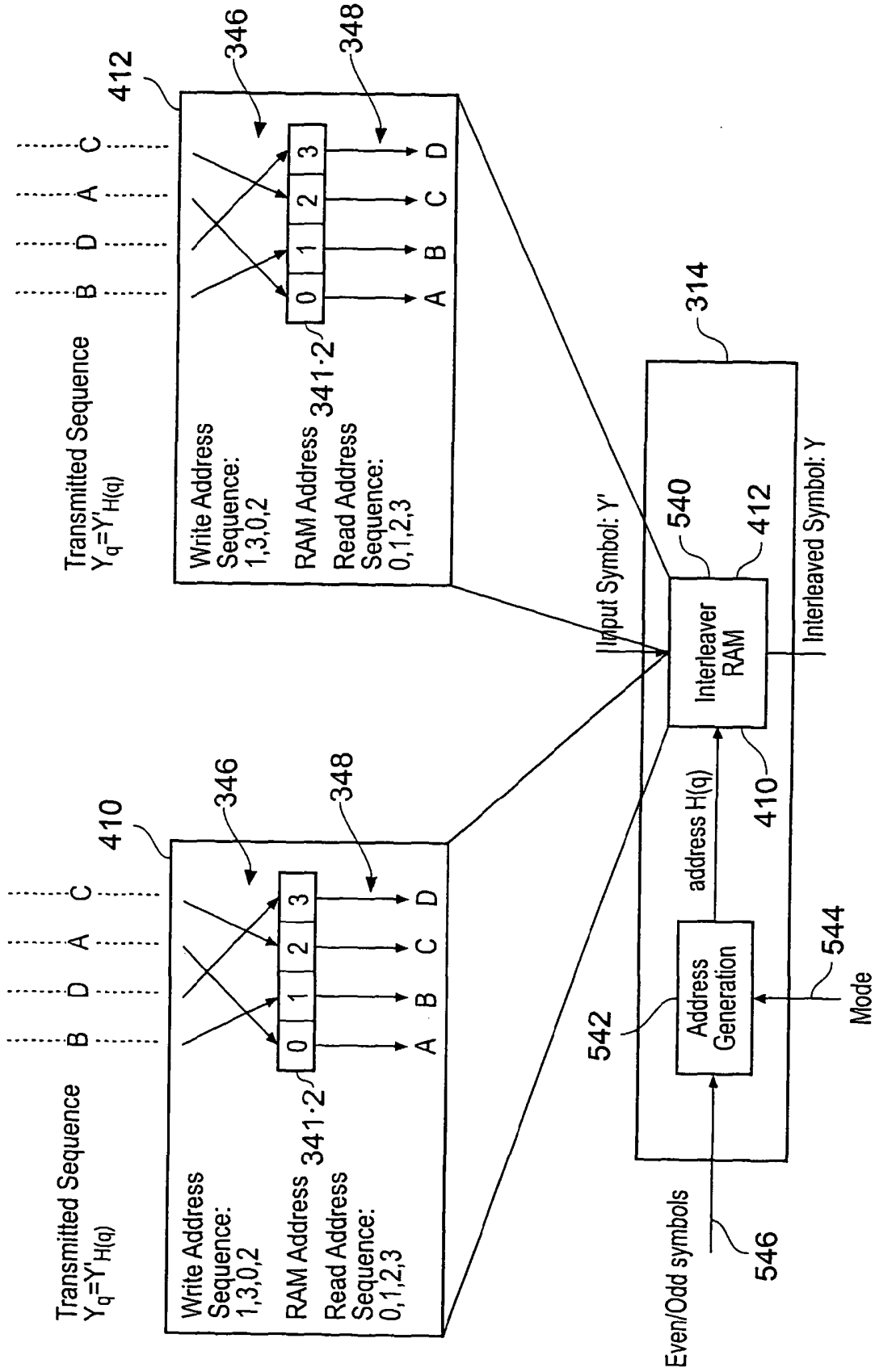

FIG. 10

DATA PROCESSING APPARATUS AND METHOD

Field of Invention

The present invention relates to data processing apparatus operable to map input symbols onto sub-carrier signals of Orthogonal Frequency Division Multiplexed (OFDM) symbols.

Embodiments of the present invention can provide an OFDM transmitter.

Background of the Invention

The Digital Video Broadcasting-Terrestrial standard (DVB-T) utilises Orthogonal Frequency Division Multiplexing (OFDM) to communicate data representing video images and sound to receivers via a broadcast radio communications signal. There are known to be two modes for the DVB-T standard which are known as the 2k and the 8k mode. The 2k mode provides 2048 sub-carriers whereas the 8k mode provides 8192 sub-carriers. Similarly for the Digital Video Broadcasting-Handheld standard (DVB-H) a 4k mode has been provided, in which the number of sub-carriers is 4096.

Error correction coding schemes such as LDPC/BCH coding, which have been proposed for DVB-T2 perform better when noise and degradation of the symbol values resulting from communication is un-correlated. Terrestrial broadcast channels may suffer from correlated fading in both the time and the frequency domains. As such, by separating encoded symbols on to different sub-carrier signals of the OFDM symbol by as much as possible, the performance of error correction coding schemes can be increased. Accordingly, in order to improve the integrity of data communicated using DVB-T or DVB-H, a symbol interleaver is provided in order to interleave input data symbols as these symbols are mapped onto the sub-carrier signals of an OFDM symbol. Such a symbol interleaver comprises an interleaver memory and an address generator. The interleaver is arranged to read-into the interleaver memory the data symbols for mapping onto the OFDM sub-carrier signals, and to read-out of the memory the data symbols for the OFDM sub-carriers, the read-out being in a different order than the read-in, the order being determined from a set of addresses, which are generated by the address generator. For the 2k mode and the 8k mode an arrangement

- has been disclosed in the DVB-T standard for generating the addresses to effect the mapping. Likewise for the 4k mode of DVB-H standard, an arrangement for generating addresses for the mapping has been provided and an address generator for implementing this mapping is disclosed in European Patent application 04251667.4.
- 5 The address generator comprises a linear feed back shift register which is operable to generate a pseudo random bit sequence and a permutation circuit. The permutation circuit permutes the order of the content of the linear feed back shift register in order to generate an address. The address provides an indication of a memory location of the interleaver memory for writing the input data symbol into or reading the input data
- 10 symbol out from the interleaver memory for mapping onto one of the sub-carrier signal of the OFDM symbol. Similarly, an address generator in the receiver is arranged to generate addresses of the interleaver memory for writing the received data symbols into or reading the data symbols out from the interleaver memory to form an output data stream.
- 15 In accordance with a further development of the Digital Video Broadcasting-Terrestrial standard, known as DVB-T2, there is a desire to improve the communication of data, and more particularly to provide an improved arrangement for interleaving the data symbols onto the sub-carrier signals of OFDM symbols.

Summary of Invention

According to an aspect of the present invention there is provided a data processing apparatus operable to map input data symbols to be communicated onto a predetermined number of sub-carrier signals of an Orthogonal Frequency Division Multiplexed (OFDM) symbols. The data processing apparatus comprises an interleaver operable to read-into a memory the predetermined number of data symbols for mapping onto the OFDM sub-carrier signals, and to read-out of the memory the data symbols for the OFDM sub-carriers to effect the mapping, the read-out being in a different order than the read-in, the order being determined from a set of addresses, with the effect that the data symbols are interleaved on the sub-carrier signals. The data processing apparatus includes an address generator operable to generate the set of addresses, an address being generated for each of the input data symbols for mapping the input data symbols onto the sub-carrier signals. The address generator comprises a linear feedback shift register including a predetermined number of register stages, which are operable to generate a pseudo-random bit sequence in accordance with a generator polynomial, a permutation circuit arranged to receive the content of the shift register stages and to permute the order of the bits present in the register stages in accordance with a permutation code to form an address of one of the OFDM sub-carriers, and a control unit operable in combination with an address check circuit to regenerate an address when a generated address exceeds a predetermined maximum valid address. The predetermined maximum valid address is approximately four thousand, the linear feedback shift register has eleven register stages with a generator polynomial for the linear feedback shift register of $R'_i[10] = R'_{i-1}[0] \oplus R'_{i-1}[2]$, and the permutation order forms, with an additional bit, a twelve bit address. The data processing apparatus is characterised in that the permutation circuit is arranged to change the permutation code, which permutes the order of the bits of the register stages to form the set of addresses from one OFDM symbol to another.

Embodiments of the present invention can provide a data processing apparatus operable as a symbol interleaver for mapping data symbols to be communicated on an OFDM symbol, having substantially four thousand sub-carrier signals, which can provide an improvement in the integrity of the communicated data. The improvement

is provided as a result of a change of the permutation code, which is used to change the order of the bits in the feed back shift register, from one OFDM symbol to another. For example, the permutation code used may be one of a sequence of different permutation codes which is cycled through, for each of a plurality of OFDM symbols.

5 As a result, an improvement is provided in reducing a possibility that successive or data bits which are close in order in an input data stream are mapped onto the same sub-carrier of an OFDM symbol, so that the error correction encoding can work more efficiently.

10 In one embodiment the number of sub-carrier signals maybe a value substantially between two thousand and four thousand and ninety six. Furthermore, the OFDM symbol may include pilot sub-carriers, which are arranged to carry known symbols, and the predetermined maximum valid address may depend on a number of the pilot sub-carrier symbols present in the OFDM symbol. As such the 4k mode can be provided with an efficient symbol interleaver, for example for a DVB standard,
15 such as DVB-T2, DVB-T or DVB-H.

In one example the sequence of different permutation codes forms the twelve bit address $R_i[n]$ for the i-th data symbol from the bit present in the n-th register stage $R_i[n]$ in accordance with the permutation code defined by the table:

| | | | | | | | | | | | |
|------------------|----|----|---|---|---|---|---|---|---|---|---|
| $R_i[n]$ for n = | 10 | 9 | 8 | 7 | 6 | 5 | 4 | 3 | 2 | 1 | 0 |
| $R_i[n]$ for n = | 7 | 10 | 5 | 8 | 1 | 2 | 4 | 9 | 0 | 3 | 6 |

20 Although the sequence of permutation codes can include any number of permutation codes, in one example there are two permutation codes. In one example, the two permutation codes are:

:

| | | | | | | | | | | | |
|------------------|----|----|---|---|---|---|---|---|---|---|---|
| $R_i[n]$ for n = | 10 | 9 | 8 | 7 | 6 | 5 | 4 | 3 | 2 | 1 | 0 |
| $R_i[n]$ for n = | 7 | 10 | 5 | 8 | 1 | 2 | 4 | 9 | 0 | 3 | 6 |

and

| | | | | | | | | | | | |
|------------------|----|---|---|----|---|---|---|---|---|---|---|
| $R_i[n]$ for n = | 10 | 9 | 8 | 7 | 6 | 5 | 4 | 3 | 2 | 1 | 0 |
| $R_i[n]$ for n = | 6 | 2 | 7 | 10 | 8 | 0 | 3 | 4 | 1 | 9 | 5 |

25

For example, the approximately four thousand sub-carriers may be provided as one of a plurality of operating modes, the approximately four thousand sub-carriers providing half or less than half a maximum number of sub-carriers in the OFDM symbols of any of the operating modes. The input data symbols may be formed into or regarded as first sets of input data symbols for mapping onto first OFDM symbols and second sets of input data symbols for mapping onto second OFDM symbols. The data processing apparatus may be operable to interleave the input data symbols from both first and second sets in accordance with an odd interleaving process. The odd interleaving process includes writing the first sets of input data symbols into a first part of the interleaver memory in accordance with a sequential order of the first sets of input data symbols, reading out the first sets of input data symbols from the first part of the interleaver memory on to the sub-carrier signals of the first OFDM symbols in accordance with an order defined by one of the permutation codes of the sequence, writing the second set of input data symbols into a second part of the interleaver memory in accordance with a sequential order of the second sets of input data symbols, and reading out the second sets of input data symbols from the second part of the interleaver memory on to the sub-carrier signals of the second OFDM symbols in accordance with an order defined by another of the permutation codes of the sequence.

The first OFDM symbols may be odd OFDM symbols, and the second OFDM symbols may be even OFDM symbols.

In some conventional OFDM transmitters and receivers, which operate in accordance with the 2k or 8k modes for DVB-T and the 4k mode for DVB-H, two symbol interleaving processes are used in the transmitter and the receiver; one for even OFDM symbols and one for odd OFDM symbols. However, analysis has shown that the interleaving schemes designed for the 2k and 8k symbol interleavers for DVB-T and the 4k symbol interleaver for DVB-H work better for odd symbols than for even symbols. Embodiments of the present invention are arranged so that only the odd symbol interleaving process is used unless the transmitter/receiver is in the mode with the maximum number of sub-carriers. Therefore, when the number data symbols which can be carried by the sub-carriers of an OFDM symbol in one of the plurality of operating modes is less than half of the number of data symbols, which can be carried in an operating mode which provides the most number of data bearing sub-carrier signals

per OFDM symbol, then an interleaver of the transmitter and the receiver of the OFDM symbols is arranged to interleaver the data symbols of both the first and second sets using the odd interleaving process. Since the interleaver is interleaving the data symbols of both the first and second sets of data symbols onto the OFDM symbols using the odd interleaving process, the interleaver uses different parts of the interleaver memory to write in and read out the data symbols. Thus, compared with the example in which the interleaver is using the odd interleaving process and the even interleaving process to interleave the first and second sets of data symbols onto successive first and second OFDM symbols, which utilises the available memory, the amount of memory capacity used is twice the number of data symbols which can be carried by an OFDM symbol for the odd only interleaving. This is compared with a memory requirement of one times the number of data symbols, which can be carried in an OFDM symbol in the mode with the most number of data symbols per OFDM symbol using both the odd and even interleaving processes. However, the number of sub-carriers per OFDM symbol for this maximum operating mode is twice the capacity of the next largest number of sub-carriers per OFDM symbol for any other operating mode with the next largest number of sub-carriers per OFDM symbol.

According to some examples therefore, a minimum size of the interleaver memory can be provided in accordance with the maximum number of input data symbols which can be carried on the sub-carriers of the OFDM symbols which are available to carry the input data symbols in any of the operating modes.

In some embodiments the operating mode which provides the maximum number of sub-carriers per OFDM symbol is a 32K mode. The other modes may include one or more of 1K, 2K, 4K, 8K and 16K modes. Thus, as will be appreciated from the above explanation, in the 32K mode the odd and even interleaving processes are used to interleave the data symbols, so that the size of the interleaver memory can be just enough to account for 32K data symbols. However, for the 16K mode and any of the other modes, then the odd interleaving process only is used, so that with the 16K mode an equivalent memory size of 32K symbols is required, with the 4K mode an equivalent memory size of 8K symbols is required, and with the 2K mode an equivalent memory size of 4K symbols is required.

Various aspects and features of the present invention are defined in the appended claims. Further aspects of the present invention include a method of mapping input symbols to be communicated onto a predetermined number of sub-carrier signals of an Orthogonal Frequency Division Multiplexed (OFDM) symbol, as
5 well as a transmitter.

Brief Description of Drawings

Embodiments of the present invention will now be described by way of example only with reference to the accompanying drawings, wherein like parts are provided with corresponding reference numerals, and in which:

5 Figure 1 is a schematic block diagram of a Coded OFDM transmitter which may be used, for example, with the DVB-T2 standard;

 Figure 2 is a schematic block diagram of parts of the transmitter shown in Figure 1 in which a symbol mapper and a frame builder illustrate the operation of an interleaver;

10 Figure 3 is a schematic block diagram of the symbol interleaver shown in Figure 2;

 Figure 4 is a schematic block diagram of an interleaver memory shown in Figure 3 and the corresponding symbol de-interleaver in the receiver;

 Figure 5 is a schematic block diagram of an address generator shown in Figure 15 3 for the 4k mode;

 Figure 6 is a schematic block diagram of a Coded OFDM receiver which may be used, for example, with the DVB-T2 standard;

 Figure 7 is a schematic block diagram of a symbol de-interleaver which appears in Figure 6;

20 Figure 8(a) is diagram illustrating results for an interleaver for even OFDM symbols and Figure 8(b) is a diagram illustrating results for odd OFDM symbols; Figures 8(a) and 8(b) show plots of the distance at the interleaver output of sub-carriers that were adjacent at the interleaver input;

 Figure 9 provides a schematic block diagram of the symbol interleaver shown 25 in Figure 3, illustrating an operating mode in which interleaving is performed in accordance with an odd interleaving mode only; and

 Figure 10 provides a schematic block diagram of the symbol de-interleaver shown in Figure 7, illustrating the operating mode in which interleaving is performed in accordance with the odd interleaving mode only.

Description of Preferred Embodiments

The following description is provided to illustrate the operation of a symbol interleaver in accordance with the present technique, although it will be appreciated that the symbol interleaver can be used with other modes, other DVB standards and other OFDM systems.

Figure 1 provides an example block diagram of a Coded OFDM transmitter which may be used for example to transmit video images and audio signals in accordance with the DVB-T2 standard. In Figure 1 a program source generates data to be transmitted by the COFDM transmitter. A video coder 2, and audio coder 4 and a data coder 6 generate video, audio and other data to be transmitted which are fed to a program multiplexer 10. The output of the program multiplexer 10 forms a multiplexed stream with other information required to communicate the video, audio and other data. The multiplexer 10 provides a stream on a connecting channel 12. There may be many such multiplexed streams which are fed into different branches A, B etc. For simplicity, only branch A will be described.

As shown in Figure 1 a COFDM transmitter 20 receives the stream at a multiplexer adaptation and energy dispersal block 22. The multiplexer adaptation and energy dispersal block 22 randomises the data and feeds the appropriate data to a forward error correction encoder 24 which performs error correction encoding of the stream. A bit interleaver 26 is provided to interleave the encoded data bits which for the example of DVB-T2 is the LDPC/BCH encoder output. The output from the bit interleaver 26 is fed to a bit into constellation mapper 28, which maps groups of bits onto a constellation point, which is to be used for conveying the encoded data bits. The outputs from the bit into constellation mapper 28 are constellation point labels that represent real and imaginary components. The constellation point labels represent data symbols formed from two or more bits depending on the modulation scheme used. These will be referred to as data cells. These data cells are passed through a time-interleaver 30 whose effect is to interleave data cells resulting from multiple LDPC code words.

The data cells are received by a frame builder 32, with data cells produced by branch B etc in Figure 1, via other channels 31. The frame builder 32 then forms many

data cells into sequences to be conveyed on COFDM symbols, where a COFDM symbol comprises a number of data cells, each data cell being mapped onto one of the sub-carriers. The number of sub-carriers will depend on the mode of operation of the system, which may include one of 1k, 2k, 4k, 8k, 16k or 32k, each of which provides a
 5 different number of sub-carriers according, for example to the following table:

| Mode | Sub-carriers |
|------|--------------|
| 1K | 756 |
| 2K | 1512 |
| 4K | 3024 |
| 8K | 6048 |
| 16K | 12096 |
| 32K | 24192 |

Number of Sub-carriers Adapted from DVB-T/H

Thus in one example, the number of sub-carriers for the 4k mode is three
 10 thousand and twenty four. For the DVB-T2 system, the number of sub-carriers per OFDM symbol can vary depending upon the number of pilot and other reserved carriers. Thus, in DVB-T2, unlike in DVB-T, the number of sub-carriers for carrying data is not fixed. Broadcasters can select one of the operating modes from 1k, 2k, 4k, 8k, 16k, 32k each providing a range of sub-carriers for data per OFDM symbol, the
 15 maximum available for each of these modes being 1024, 2048, 4096, 8192, 16384, 32768 respectively. In DVB-T2 a physical layer frame is composed of many OFDM symbols. Typically the frame starts with one or more preamble or P2 OFDM symbols, which are then followed by a number payload carrying OFDM symbols. The end of the physical layer frame is marked by a frame closing symbols. For each operating
 20 mode, the number of sub-carriers may be different for each type of symbol. Furthermore, this may vary for each according to whether bandwidth extension is selected, whether tone reservation is enabled and according to which pilot sub-carrier pattern has been selected. As such a generalisation to a specific number of sub-carriers per OFDM symbol is difficult. However, the frequency interleaver for each mode can
 25 interleave any symbol whose number of sub-carriers is smaller than or the same as the maximum available number of sub-carriers for the given mode. For example, in the 1k mode, the interleaver would work for symbols with the number of sub-carriers being

less than or equal to 1024 and for 16k mode, with the number of sub-carriers being less than or equal to 16384.

The sequence of data cells to be carried in each COFDM symbol is then passed to the symbol interleaver 33. The COFDM symbol is then generated by a COFDM symbol builder block 37 which introduces pilot and synchronising signals fed from a pilot and embedded signal former 36. An OFDM modulator 38 then forms the OFDM symbol in the time domain which is fed to a guard insertion processor 40 for generating a guard interval between symbols, and then to a digital to analogue convertor 42 and finally to an RF amplifier within an RF front end 44 for eventual broadcast by the COFDM transmitter from an antenna 46.

As explained above, the present invention provides a facility for providing a quasi-optimal mapping of the data symbols onto the OFDM sub-carrier signals. According to the example technique the symbol interleaver is provided to effect the optimal mapping of input data symbols onto COFDM sub-carrier signals in accordance with a permutation code and generator polynomial, which has been verified by simulation analysis.

As shown in Figure 2 a more detailed example illustration of the bit to symbol constellation mapper 28 and the frame builder 32 is provided to illustrate an example embodiment of the present technique. Data bits received from the bit interleaver 26 via a channel 62 are grouped into sets of bits to be mapped onto a data cell, in accordance with a number of bits per symbol provided by the modulation scheme. The groups of bits, which forms a data word, are fed in parallel via data channels 64 to a mapping processor 66. The mapping processor 66 then selects one of the data symbols, in accordance with a pre-assigned mapping. The constellation point, is represented by a real and an imaginary component that is provided to the output channel 29 as one of a set of inputs to the frame builder 32.

The frame builder 32 receives the data cells from the bit to constellation mapper 28 through channel 29, together with data cells from the other channels 31. After building a frame of many COFDM cell sequences, the cells of each COFDM symbol are then written into an interleaver memory 100 and read out of the interleaver memory 100 in accordance with write addresses and read addresses generated by an address generator 102. According to the write-in and read-out order, interleaving of

the data cells is achieved, by generating appropriate addresses. The operation of the address generator 102 and the interleaver memory 100 will be described in more detail shortly with reference to Figures 3, 4 and 5. The interleaved data cells are then combined with pilot and synchronisation symbols received from the pilot and embedded signalling former 36 into an OFDM symbol builder 37, to form the COFDM symbol, which is fed to the OFDM modulator 38 as explained above.

Interleaver

Figure 3 provides an example of parts of the symbol interleaver 33, which illustrates the present technique for interleaving symbols. In Figure 3 the input data cells from the frame builder 32 are written into the interleaver memory 100. The data cells are written into the interleaver memory 100 according to a write address fed from the address generator 102 on channel 104, and read out from the interleaver memory 100 according to a read address fed from the address generator 102 on a channel 106. The address generator 102 generates the write address and the read address as explained below, depending on whether the COFDM symbol is odd or even, which is identified from a signal fed from a channel 108, and depending on a selected mode, which is identified from a signal fed from a channel 110. As explained, the mode can be one of a 1k mode, 2k mode, 4k mode, 8k mode, 16k mode or a 32k mode. As explained below, the write address and the read address are generated differently for odd and even symbols as explained with reference to Figure 4, which provides an example implementation of the interleaver memory 100.

In the example shown in Figure 4, the interleaver memory is shown to comprise an upper part 100 illustrating the operation of the interleaver memory in the transmitter and a lower part 340, which illustrates the operation of the de-interleaver memory in the receiver. The interleaver 100 and the de-interleaver 340 are shown together in Figure 4 in order to facilitate understanding of their operation. As shown in Figure 4 a representation of the communication between the interleaver 100 and the de-interleaver 340 via other devices and via a transmission channel has been simplified and represented as a section 140 between the interleaver 100 and the de-interleaver 340. The operation of the interleaver 100 is described in the following paragraphs:

Although Figure 4 provides an illustration of only four input data cells onto an example of four sub-carrier signals of a COFDM symbol, it will be appreciated that the technique illustrated in Figure 4 can be extended to a larger number of sub-carriers such as 756 for the 1k mode 1512 for the 2k mode, 3024 for the 4k mode and 6048 for the 8k mode, 12096 for the 16k mode and 24192 for the 32k mode.

The input and output addressing of the interleaver memory 100 shown in Figure 4 is shown for odd and even symbols. For an even COFDM symbol the data cells are taken from the input channel 77 and written into the interleaver memory 124.1 in accordance with a sequence of addresses 120 generated for each COFDM symbol by the address generator 102. The write addresses are applied for the even symbol so that as illustrated interleaving is effected by the shuffling of the write-in addresses. Therefore, for each interleaved symbol $y(h(q)) = y'(q)$.

For odd symbols the same interleaver memory 124.2 is used. However, as shown in Figure 4 for the odd symbol the write-in order 132 is in the same address sequence used to read out the previous even symbol 126. This feature allows the odd and even symbol interleaver implementations to only use one interleaver memory 100 provided the read-out operation for a given address is performed before the write-in operation. The data cells written into the interleaver memory 124 during odd symbols are then read out in a sequence 134 generated by the address generator 102 for the next even COFDM symbol and so on. Thus only one address is generated per symbol, with the read-in and write-out for the odd/even COFDM symbol being performed contemporaneously.

In summary, as represented in Figure 4, once the set of addresses $H(q)$ has been calculated for all active sub-carriers, the input vector $Y' = (y_0', y_1', y_2', \dots, y_{N_{\max}-1}')$ is processed to produce the interleaved vector $Y = (y_0, y_1, y_2, \dots, y_{N_{\max}-1})$ defined by:

$$y_{H(q)} = y'_q \text{ for even symbols for } q = 0, \dots, N_{\max}-1$$

$$y_q = y'_{H(q)} \text{ for odd symbols for } q = 0, \dots, N_{\max}-1$$

In other words, for even OFDM symbols the input words are written in a permuted way into a memory and read back in a sequential way, whereas for odd

symbols, they are written sequentially and read back permuted. In the above case, the permutation $H(q)$ is defined by the following table:

| q | 0 | 1 | 2 | 3 |
|------|---|---|---|---|
| H(q) | 1 | 3 | 0 | 2 |

Table 1: permutation for simple case where $N_{max} = 4$

5 As shown in Figure 4, the de-interleaver 340 operates to reverse the interleaving applied by the interleaver 100, by applying the same set of addresses as generated by an equivalent address generator, but applying the write-in and read-out addresses in reverse. As such, for even symbols, the write-in addresses 342 are in sequential order, whereas the read out address 344 are provided by the address
10 generator. Correspondingly, for the odd symbols, the write-in order 346 is determined from the set of addresses generated by the address generator, whereas read out 348 is in sequential order.

Address Generation for the 4k Mode

A schematic block diagram of the algorithm used to generate the permutation
15 function $H(q)$ is represented in Figure 5 for the 4K mode. In Figure 5 a linear feed back shift register is formed by eleven shift register stages 200, in order to generate an address between 0 and four thousand and ninety five, and an xor-gate 202 which is connected to the stages of the shift register 200 in accordance with a generator polynomial. Therefore, in accordance with the content of the shift register 200 a next
20 bit of the shift register is provided from the output of the xor-gate 202 by xoring the content of shift register $R[0]$ and register stage $R[2]$. According to the generator polynomial a pseudo random bit sequence is generated from the content of the shift register 200. However, in order to generate an address for the 4k mode as illustrated, a permutation circuit 210 is provided which effectively permutes the order of the bits
25 within the shift register 200 from an order $R'_i[n]$ to an order $R_i[n]$ at the output of the permutation circuit 210. Eleven bits from the output of the permutation circuit 210 are then fed on a connecting channel 212 to which is added a most significant bit via a channel 214 which is provided by a toggle circuit 218. A twelve bit address is therefore generated on channel 212. However, in order to ensure the authenticity of an
30 address, an address check circuit 216 analyses the generated address to determine

whether it exceeds the maximum number of sub-carrier signals. If it does then a control signal is generated and fed via a connecting channel 220 to a control unit 224. If the generated address exceeds the maximum number of carrier signals then this address is rejected and a new address regenerated for the particular symbol.

- 5 In summary an $(N_r - 1)$ bit word R'_i is defined, with $N_r = \log_2 M_{\max}$, where $M_{\max} = 4096$ in the 4K mode, using a LFSR (Linear Feedback Shift Register).

The polynomials used to generate this sequence are as follows:

$$4K \text{ mode: } R'_i[10] = R'_{i-1}[0] \oplus R'_{i-1}[2]$$

where i varies from 0 to $M_{\max} - 1$

- 10 Once one R'_i word has been generated, it goes through a permutation to produce another $(N_r - 1)$ bit word called R_i . R_i is derived from R'_i by the bit permutations given in the table below:

| | | | | | | | | | | | |
|---------------------|----|----|---|---|---|---|---|---|---|---|---|
| $R'_i[n]$ for $n =$ | 10 | 9 | 8 | 7 | 6 | 5 | 4 | 3 | 2 | 1 | 0 |
| $R_i[n]$ for $n =$ | 7 | 10 | 5 | 8 | 1 | 2 | 4 | 9 | 0 | 3 | 6 |

Table: Bit permutation for the 4K mode

- 15 As an example, for the permutation code above this means that for mode 4K, the bit number 10 of R'_i is sent in bit position number 7 of R_i .

The address $H(q)$ is then derived from R_i through the following equation:

$$H(q) = (i \bmod 2) \cdot 2^{N_r-1} + \sum_{j=0}^{N_r-2} R_i(j) \cdot 2^j$$

- 20 The $(i \bmod 2) \cdot 2^{N_r-1}$ part of the above equation is represented in Figure 5 by the toggle block T 218.

- An address check is then performed on $H(q)$ to verify that the generated address is within the range of acceptable addresses: if $(H(q) < N_{\max})$, where, in one example $N_{\max} = 3024$ in the 4K mode, then the address is valid. If the address is not valid, the control unit is informed and it will try to generate a new $H(q)$ by
25 incrementing the index i .

The role of the toggle block is to make sure that we do not generate an address exceeding N_{\max} twice in a row. In effect, if an exceeding value was generated, this

means that the MSB (i.e. the toggle bit) of the address $H(q)$ was one. So the next value generated will have a MSB set to zero, insuring to produce a valid address.

The following equations sum up the overall behaviour and help to understand the loop structure of this algorithm:

```

5      q = 0;
      for (i = 0; i < Mmax; i = i + 1)
        { H(q) = (i mod 2) · 2Nr-1 + ∑j=0Nr-2 Ri(j) · 2j;
          if (H(q) < Nmax) q = q + 1; }

```

As will be explained shortly, in one example of the address generator, the above mentioned permutation code is used for generating addresses for all OFDM symbols. In another example, the permutation codes may be changed between successive OFDM symbols, with the effect that a set of permutation codes are cycled through for successive OFDM symbols. To this end, the control lines 108, 110 providing an indication as to whether the OFDM symbol is odd or even and the current mode are used to select the permutation code. This example mode in which a plurality of permutation codes are cycled through is particularly appropriate for the example in which the odd interleaver only is used, which will be explained later. A signal indicating that a different permutation code should be used is provided via a control channel 111. In one example the possible permutation codes are pre-stored in the permutation code circuit 210. In another example, the control unit 224 supplies the new permutation code to be used for an OFDM symbol.

Receiver

Figure 6 provides an example illustration of a receiver which may be used with the present technique. As shown in Figure 6, a COFDM signal is received by an antenna 300 and detected by a tuner 302 and converted into a digital form by an analogue-to-digital converter 304. A guard interval removal processor 306 removes the guard interval from a received COFDM symbol, before the data is recovered from the COFDM symbol using a Fast Fourier Transform (FFT) processor 308 in combination with a channel estimator and correction 310 in co-operation with an embedded-signalling decoding unit 311, in accordance with known techniques. The

demodulated data is recovered from a mapper 312 and fed to a symbol de-interleaver 314, which operates to effect the reverse mapping of the received data symbol to regenerate an output data stream with the data de-interleaved.

The symbol de-interleaver 314 is formed from a data processing apparatus as shown in Figure 6 with an interleaver memory 540 and an address generator 542. The interleaver memory is as shown in Figure 4 and operates as already explained above to effect de-interleaving by utilising sets of addresses generated by the address generator 542. The address generator 542 is formed as shown in Figure 7 and is arranged to generate corresponding addresses to map the data symbols recovered from each COFDM sub-carrier signals into an output data stream.

The remaining parts of the COFDM receiver shown in Figure 6 are provided to effect error correction decoding 318 to correct errors and recover an estimate of the source data.

One advantage provided by the present technique for both the receiver and the transmitter is that a symbol interleaver and a symbol de-interleaver operating in the receivers and transmitters can be switched between the 1k, 2k, 4k, 8k, 16k and the 32k mode by changing the generator polynomials and the permutation order. Hence the address generator 542 shown in Figure 7 includes an input 544, providing an indication of the mode as well as an input 546 indicating whether there are odd/even COFDM symbols. A flexible implementation is thereby provided because a symbol interleaver and de-interleaver can be formed as shown in Figures 3 and 7, with an address generator as illustrated in Figure 5. The address generator can therefore be adapted to the different modes by changing to the generator polynomials and the permutation orders indicated for each of the modes. For example, this can be effected using a software change. Alternatively, in other embodiments, an embedded signal indicating the mode of the DVB-T2 transmission can be detected in the receiver in the embedded-signalling processing unit 311 and used to configure automatically the symbol de-interleaver in accordance with the detected mode.

Optimal Use of Odd Interleavers

As shown in Figure 4, two symbol interleaving processes, one for even COFDM symbols and one for odd COFDM symbols allows the amount of memory used during interleaving to be reduced. In the example shown in Figure 4, the write in

order for the odd symbol is the same as the read out order for the even symbol therefore, while an odd symbol is being read from the memory, an even symbol can be written to the location just read from; subsequently, when that even symbol is read from the memory, the following odd symbol can be written to the location just read from.

The selection of the polynomial generator and the permutation codes explained above have been identified following simulation analysis of the relative performance of the interleaver. The relative performance of the interleaver has been evaluated using a relative ability of the interleaver to separate successive symbols or an “interleaving quality”. The relative measure of the interleaver quality is determined by defining a distance D (in number of sub-carriers). A criterion C is chosen to identify a number of sub-carriers that are at distance $\leq D$ at the output of the interleaver that were at distance $\leq D$ at the input of the interleaver, the number of sub-carriers for each distance D then being weighted with respect to the relative distance. The criterion C is evaluated for both odd and even COFDM symbols. Minimising C produces a superior quality interleaver.

$$C = \sum_1^{d=D} N_{\text{even}}(d) / d + \sum_1^{d=D} N_{\text{odd}}(d) / d$$

where: $N_{\text{even}}(d)$ and $N_{\text{odd}}(d)$ are number of sub-carriers in an even and odd symbol respectively at the output of the interleaver that remain within d sub-carrier spacing of each other.

As mentioned above, during an experimental analysis of the performance of the interleavers (using criterion C as defined above) and for example shown in Figure 8(a) and Figure 8(b) it has been discovered that the interleaving schemes designed for the 2k and 8k symbol interleavers for DVB-T and the 4k symbol interleaver for DVB-H work better for odd symbols than even symbols. Thus from performance evaluation results of the interleavers, for example for the 16K, as illustrated by Figures 8(a) and 8(b) it has been revealed that the odd interleavers work better than the even interleavers. This can be seen by comparing Figure 8(a) which shows results for an interleaver for even symbols and Figure 8(b) illustrating results for odd symbols: it can be seen that the average distance at the interleaver output of sub-carriers that were

adjacent at the interleaver input is greater for an interleaver for odd symbols than an interleaver for even symbols.

As will be understood, the amount of interleaver memory required to implement a symbol interleaver is dependent on the number of data symbols to be mapped onto the COFDM carrier symbols. Thus a 16k mode symbol interleaver requires half the memory required to implement a 32k mode symbol interleaver and similarly, the amount of memory required to implement an 8k symbol interleaver is half that required to implement a 16k interleaver. Therefore a transmitter or receiver which is arranged to implement a symbol interleaver of a mode, which sets the maximum number of data symbols which can be carried per OFDM symbol, then that receiver or transmitter will include sufficient memory to implement two odd interleaving processes for any other mode, which provides half or smaller than half the number of sub-carriers per OFDM symbol in that given maximum mode. For example a receiver or transmitter including a 32K interleaver will have enough memory to accommodate two 16K odd interleaving processes each with their own 16K memory.

Therefore, in order to exploit the better performance of the odd interleaving process, a symbol interleaver capable of accommodating multiple modulation modes can be arranged so that only an odd symbol interleaving process is used if in a mode which comprises half or less than half of the number of sub-carriers in a maximum mode, which represents the maximum number of sub-carriers per OFDM symbol. This maximum mode therefore sets the maximum memory size. For example, in a transmitter/receiver capable of the 32K mode, when operating in a mode with fewer carriers (i.e. 16K, 8K, 4K or 1K) then rather than employing separate odd and even symbol interleaving processes, two odd interleavers could be used.

An illustration is shown in Figure 9 of an adaptation of the symbol interleaver 33, which is shown in Figure 3 when interleaving input data symbols onto the sub-carriers of OFDM symbols in the odd interleaving mode only. The symbol interleaver 33.1 corresponds exactly to the symbol interleaver 33 as shown in Figure 3, except that the address generator 102.1 is adapted to perform the odd interleaving process only. For the example shown in Figure 9, the symbol interleaver 33.1 is operating in a mode where the number of data symbols which can be carried per OFDM symbol is less than half of the maximum number which can be carried by an OFDM symbol in an

operating mode with the largest number of sub-carriers per OFDM symbol. As such, the symbol interleaver 33.1 has been arranged to partition the interleaver memory 100. For the present illustration shown in Figure 9 the interleaver memory then 100 is divided into two parts 401, 402. As an illustration of the symbol interleaver 33.1
5 operating in a mode in which data symbols are mapped onto the OFDM symbols using the odd interleaving process, Figure 9 provides an expanded view of each half of the interleaver memory 401, 402. The expanded view provides an illustration of the odd interleaving mode as represented for the transmitter side for four symbols A, B, C, D reproduced from Figure 4. Thus as shown in Figure 9, for successive sets of first and
10 second data symbols, the data symbols are written into the interleaver memory 401, 402 in a sequential order and read out in a permuted order in accordance with the addresses generated by the address generator 102 as previously explained. Thus as illustrated in Figure 9, since an odd interleaving process is being performed for successive sets of first and second sets of data symbols, the interleaver memory must
15 be partitioned into two parts. Symbols from a first set of data symbols are written into a first half of the interleaver memory 401, and symbols from a second set of data symbols are written into a second part of the interleaver memory 402. This is because the symbol interleaver is no longer able to reuse the same parts of the symbol interleaver memory as can be accommodated when operating in an odd and even mode
20 of interleaving.

A corresponding example of the interleaver in the receiver, which appears in Figure 7 but adapted to operate with an odd interleaving process only, is shown in Figure 10. As shown in Figure 10 the interleaver memory 540 is divided into two halves 410, 412 and the address generator 542 is adapted to write data symbols into the
25 interleaver memory and read data symbols from the interleaver memory into respective parts of the memory 410, 402 for successive sets of data symbols to implement an odd interleaving process only. Therefore, in correspondence with representation shown in Figure 9, Figure 10 shows the mapping of the interleaving process which is performed at the receiver and illustrated in Figure 4 as an expanded view operating for both the
30 first and second halves of the interleaving memory 410, 412. Thus a first set of data symbols are written into a first part of the interleaver memory 410 in a permuted order defined in accordance with the addresses generated by the address generator 542 as

illustrated by the order of writing in the data symbols which provides a write sequence of 1, 3, 0, 2. As illustrated the data symbols are then read out of the first part of the interleaver memory 410 in a sequential order thus recovering the original sequence A, B, C, D.

5 Correspondingly, a second subsequent set of data symbols which are recovered from a successive OFDM symbol are written into the second half of the interleaver memory 412 in accordance with the addresses generated by the address generator 542 in a permuted order and read out into the output data stream in a sequential order.

10 In one example the addresses generated for a first set of data symbols to write into the first half of the interleaver memory 410 can be reused to write a second subsequent set of data symbols into the interleaver memory 412. Correspondingly, the transmitter may also reuse addresses generated for one half of the interleaver for a first set of data symbols for reading out a second set of data symbols which have been written into the second half of the memory in sequential order.

15 **Odd Interleaver with Offset**

The performance of an interleaver, which uses two odd interleavers could be further improved by using a sequence of odd only interleavers rather than a single odd only interleaver, so that any bit of data input to the interleave does not always modulate the same carrier in the OFDM symbol.

20 A sequence of odd only interleavers could be realised by either:

- adding an offset to the interleaver address modulo the number of data carriers, or
- using a sequence of permutations in the interleaver

Adding an Offset

25 Adding an offset to the interleaver address modulo the number of data carriers effectively shifts and wraps-round the OFDM symbol so that any bit of data input to the interleaver does not always modulate the same carrier in the OFDM symbol. Thus the address generator, could optionally include an offset generator, which generates an offset in an address generated by the address generator on the output channel $H(q)$.

The offset would change each symbol. For example, this offset could provide be a cyclic sequence. This cyclic sequence could be, for example, of length 4 and could consist of, for example, prime numbers. For example, such a sequence could be:

0, 41, 97, 157

5 Furthermore, the offset may be a random sequence, which may be generated by another address generator from a similar OFDM symbol interleaver or may be generated by some other means.

Using a Sequence of Permutations

10 As shown in Figures 5, a control line 111 extends from the control unit of the address generator to the permutation circuit. As mentioned above, in one example the address generator can apply a different permutation code from a set of permutation codes for successive OFDM symbols. Using a sequence of permutations in the interleaver address generator reduces a likelihood that any bit of data input to the interleaver does not always modulate the same sub-carrier in the OFDM symbol.

15 For example, this could be a cyclic sequence, so that a different permutation code in a set of permutation codes in a sequence is used for successive OFDM symbols and then repeated. This cyclic sequence could be, for example, of length two or four. For the example of the 4K symbol interleaver a sequence of two permutation codes which are cycled through per OFDM symbol could be for example:

20 7 10 5 8 1 2 4 9 0 3 6 **

6 2 7 10 8 0 3 4 1 9 5

Whereas a sequence of four permutation codes could be:

7 10 5 8 1 2 4 9 0 3 6 **

6 2 7 10 8 0 3 4 1 9 5

25 9 5 4 2 3 10 1 0 6 8 7

1 4 10 3 9 7 2 6 5 0 8

30 The switching of one permutation code to another could be effected in response to a change in the Odd/Even signal indicated on the control channel 108. In response the control unit 224 changes the permutation code in the permutation code circuit 210 via the control line 111.

For the example of a 1k symbol interleaver, two permutation codes could be:

4 3 2 1 0 5 6 7 8

3 2 5 0 1 4 7 8 6

whereas four permutation codes could be:

4 3 2 1 0 5 6 7 8

5 3 2 5 0 1 4 7 8 6

7 5 3 8 2 6 1 4 0

1 6 8 2 5 3 4 0 7

Other combinations of sequences may be possible for 2k, 4k and 16k carrier modes or indeed 0.5k carrier mode. For example, the following permutation codes for each of the 0.5k, 2k, 4k and 16k provide good de-correlation of symbols and can be used cyclically to generate the offset to the address generated by an address generator for each of the respective modes:

2k Mode:

0 7 5 1 8 2 6 9 3 4 *

15 4 8 3 2 9 0 1 5 6 7

8 3 9 0 2 1 5 7 4 6

7 0 4 8 3 6 9 1 5 2

8k Mode:

20 5 11 3 0 10 8 6 9 2 4 1 7 *

8 10 7 6 0 5 2 1 3 9 4 11

11 3 6 9 2 7 4 10 5 1 0 8

10 8 1 7 5 6 0 11 4 2 9 3

25 16k Mode:

8 4 3 2 0 11 1 5 12 10 6 7 9

7 9 5 3 11 1 4 0 2 12 10 8 6

6 11 7 5 2 3 0 1 10 8 12 9 4

5 12 9 0 3 10 2 4 6 7 8 11 1

30

For the permutation codes indicated above, the first two could be used in a two sequence cycle, whereas all four could be used for a four sequence cycle. In addition,

some further sequences of four permutation codes, which are cycled through to provide the offset in an address generator to produce a good de-correlation in the interleaved symbols (some are common to the above) are provided below:

0.5k Mode:

5 3 7 4 6 1 2 0 5
 4 2 5 7 3 0 1 6
 5 3 6 0 4 1 2 7
 6 1 0 5 2 7 4 3

10 2k Mode:

 0 7 5 1 8 2 6 9 3 4 *
 3 2 7 0 1 5 8 4 9 6
 4 8 3 2 9 0 1 5 6 7
 7 3 9 5 2 1 0 6 4 8

15

 4k Mode:

 7 10 5 8 1 2 4 9 0 3 6 **
 6 2 7 10 8 0 3 4 1 9 5
 10 3 4 1 2 7 0 6 8 5 9

20 0 8 9 5 10 4 6 3 2 1 7

 8k Mode:

 5 11 3 0 10 8 6 9 2 4 1 7 *
 10 8 5 4 2 9 1 0 6 7 3 11

25 11 6 9 8 4 7 2 1 0 10 5 3
 8 3 11 7 9 1 5 6 4 0 2 10

*these are the permutations in the DVB-T standard

**these are the permutations in the DVB-H standard

30 Examples of address generators, and corresponding interleavers, for the 2k, 4k and 8k modes are disclosed in European patent EP1463256, the contents of which are incorporated herein by reference. An address generator for the 0.5k mode are

disclosed in our co-pending UK patent application number 0722553.5. Various modifications may be made to the embodiments described above without departing from the scope of the present invention. In particular, the example representation of the generator polynomial and the permutation order which have been used to represent aspects of the invention are not intended to be limiting and extend to equivalent forms of the generator polynomial and the permutation order.

As will be appreciated the transmitter and receiver shown in Figures 1 and 6 respectively are provided as illustrations only and are not intended to be limiting. For example, it will be appreciated that the position of the symbol interleaver and the de-interleaver with respect, for example to the bit interleaver and the mapper can be changed. As will be appreciated the effect of the interleaver and de-interleaver is unchanged by its relative position, although the interleaver may be interleaving I/Q symbols instead of v-bit vectors. A corresponding change may be made in the receiver. Accordingly the interleaver and de-interleaver may be operating on different data types, and may be positioned differently to the position described in the example embodiments.

Aspects and features of a transmitter according to the present technique are defined in the appended claims. An example of a receiver for use in receiving data transmitted by a transmitter embodying the present invention may include a data processing apparatus operable to map symbols received from a predetermined number of sub-carrier signals of an Orthogonal Frequency Division Multiplexed (OFDM) symbol into an output symbol stream.

As explained above the permutation codes and generator polynomial of the interleaver, which has been described with reference to an implementation of a particular mode, can equally be applied to other modes, by changing the predetermined maximum allowed address in accordance with the number of sub-carriers for that mode.

As mentioned above, embodiments of the present invention find application with DVB standards such as DVB-T, DVB-T2 and DVB-H, which are incorporated herein by reference. For example embodiments of the present invention may be used in a transmitter or receiver operating in accordance with the DVB-H standard, in hand-held mobile terminals. The mobile terminals may be integrated with mobile telephones

(whether second, third or higher generation) or Personal Digital Assistants or Tablet PCs for example. Such mobile terminals may be capable of receiving DVB-H or DVB-T/T2 compatible signals inside buildings or on the move in for example cars or trains, even at high speeds. The mobile terminals may be, for example, powered by batteries, mains electricity or low voltage DC supply or powered from a car battery. Services that may be provided by DVB-H may include voice, messaging, internet browsing, radio, still and/or moving video images, television services, interactive services, video or near-video on demand and option. The services might operate in combination with one another. In other examples embodiments of the present invention finds application with the DVB-T2 standard as specified in accordance with ETSI standard EN 302 755. In other examples embodiments of the present invention find application with the cable transmission standard known as DVB-C2. However, it will be appreciated that the present invention is not limited to application with DVB and may be extended to other standards for transmission or reception, both fixed and mobile.

The following numbered clauses provide further example implementations of a transmitter, a method of transmission and an address generator:

1. A data processing apparatus operable to map input symbols to be communicated onto a predetermined number of sub-carrier signals of Orthogonal Frequency Division Multiplexed (OFDM) symbols, the data processing apparatus comprising

an interleaver operable to read-into a memory the predetermined number of data symbols for mapping onto the OFDM sub-carrier signals, and to read-out of the memory the data symbols for the OFDM sub-carriers to effect the mapping, the read-out being in a different order than the read-in, the order being determined from a set of addresses, with the effect that the data symbols are interleaved on the sub-carrier signals,

an address generator operable to generate the set of addresses, an address being generated for each of the input symbols for mapping the input data symbol on to one of the sub-carrier signals, the address generator comprising

a linear feedback shift register including a predetermined number of register stages and being operable to generate a pseudo-random bit sequence in accordance with a generator polynomial,

a permutation circuit operable to receive the content of the shift register stages and to permute the order of the bits present in the register stages in accordance with a permutation code to form an address, and

5 a control unit operable in combination with an address check circuit to regenerate an address when a generated address exceeds a predetermined maximum valid address, wherein

the predetermined maximum valid address is approximately four thousand,

the linear feedback shift register has eleven register stages with a generator polynomial for the linear feedback shift register of $R_i'[10] = R_{i-1}'[0] \oplus R_{i-1}'[2]$, and the
10 permutation code forms, with an additional bit, a twelve bit address, characterised in that

the permutation circuit is arranged to change the permutation code, which permutes the order of the bits of the register stages to form the addresses from one OFDM symbol to another.

15 2. A data processing apparatus according to clause 1, wherein the permutation circuit is operable to cycle through a sequence of different permutation codes for successive OFDM symbols.

3. A data processing apparatus according to clause 2, wherein one of the sequence of different permutation codes forms the twelve bit address $R_i[n]$ for the i-th
20 data symbol from the bit present in the n-th register stage $R_i'[n]$ in accordance with the permutation code defined by the table:

| | | | | | | | | | | | |
|-------------------|----|----|---|---|---|---|---|---|---|---|---|
| $R_i'[n]$ for n = | 10 | 9 | 8 | 7 | 6 | 5 | 4 | 3 | 2 | 1 | 0 |
| $R_i[n]$ for n = | 7 | 10 | 5 | 8 | 1 | 2 | 4 | 9 | 0 | 3 | 6 |

4. A data processing apparatus according to clause 2 or 3, wherein the sequence of permutation codes comprises two permutation codes, which are:

| | | | | | | | | | | | |
|-------------------|----|----|---|---|---|---|---|---|---|---|---|
| $R_i'[n]$ for n = | 10 | 9 | 8 | 7 | 6 | 5 | 4 | 3 | 2 | 1 | 0 |
| $R_i[n]$ for n = | 7 | 10 | 5 | 8 | 1 | 2 | 4 | 9 | 0 | 3 | 6 |

25 and

| | | | | | | | | | | | |
|--------------------|----|---|---|----|---|---|---|---|---|---|---|
| $R_i[n]$ for $n =$ | 10 | 9 | 8 | 7 | 6 | 5 | 4 | 3 | 2 | 1 | 0 |
| $R_i[n]$ for $n =$ | 6 | 2 | 7 | 10 | 8 | 0 | 3 | 4 | 1 | 9 | 5 |

5. A data processing apparatus according to any of clauses 1 to 4, wherein the predetermined maximum valid address is a value substantially between two thousand and four thousand and ninety six.
- 5 6. A data processing apparatus according to clause 5, wherein the OFDM symbol includes pilot sub-carriers, which are arranged to carry known symbols, and the predetermined maximum valid address depends on a number of the pilot sub-carrier symbols present in the OFDM symbol.
7. A data processing apparatus according to any of clauses 1 to 6, wherein
10 the approximately four thousand sub-carriers is provided by one of a plurality of operating modes in which the approximately four thousand sub-carriers provides half or less than half a maximum number of sub-carriers in the OFDM symbols of any of the operating modes, and the input data symbols include first sets of input data symbols for mapping onto first OFDM symbols and second sets of input data symbols
15 for mapping onto second OFDM symbols, and the data processing apparatus is operable to interleave the input data symbols from both first and second sets in accordance with an odd interleaving process,
the odd interleaving process including
writing the first sets of input data symbols into a first part of the interleaver
20 memory in accordance with a sequential order of the first sets of input data symbols,
reading out the first sets of input data symbols from the first part of the interleaver memory on to the sub-carrier signals of the first OFDM symbols in accordance with an order defined by the set of addresses generated with one of the permutation codes of the sequence,
25 writing the second set of input data symbols into a second part of the interleaver memory in accordance with a sequential order of the second sets of input data symbols, and
reading out the second sets of input data symbols from the second part of the interleaver memory on to the sub-carrier signals of the second OFDM symbols in

accordance with an order defined by the set of addresses generated with another of the permutation codes of the sequence.

8. A transmitter for transmitting input data symbols using Orthogonal Frequency Division Multiplexing (OFDM), the transmitter including a data processing apparatus for mapping the input data symbols on a predetermined number of sub-carrier signals of OFDM symbols, the data processing apparatus comprising
- 5 an interleaver operable to read-into a memory the predetermined number of data symbols for mapping onto the OFDM sub-carrier signals, and to read-out of the memory the data symbols for the OFDM sub-carriers to effect the mapping, the read-out being in a different order than the read-in, the order being determined from a set of addresses, with the effect that the data symbols are interleaved on the sub-carrier signals,
- 10 an address generator operable to generate the set of addresses, an address being generated for each of the input symbols for mapping on to one of the sub-carrier signals, the address generator comprising
- 15 a linear feedback shift register including a predetermined number of register stages and being operable to generate a pseudo-random bit sequence in accordance with a generator polynomial,
- a permutation circuit operable to receive the content of the shift register stages and to permute the order of the bits present in the register stages in accordance with a permutation code to form an address, and
- 20 a control unit operable in combination with an address check circuit to regenerate an address when a generated address exceeds a predetermined maximum valid address, wherein
- 25 the predetermined maximum valid address is approximately four thousand,
- the linear feedback shift register has eleven register stages with a generator polynomial for the linear feedback shift register of $R'_i[10] = R'_{i-1}[0] \oplus R'_{i-1}[2]$, and the permutation code forms, with an additional bit, a twelve bit address, characterised in that
- 30 the permutation circuit is arranged to change the permutation code, which permutes the order of the bits of the register stages to form the addresses from one OFDM symbol to another.

9. A transmitter according to clause 8, wherein the transmitter is operable to transmit data in accordance with a Digital Video Broadcasting standard such as the Digital Video Broadcasting-Terrestrial, Digital Video Broadcasting-Handheld standard or the Digital Video Broadcasting-Terrestrial2 standard.

- 5 10. A method of mapping input symbols to be communicated onto a predetermined number of sub-carrier signals of an Orthogonal Frequency Division Multiplexed (OFDM) symbols, the method comprising
- reading-into a memory the predetermined number of data symbols for mapping onto the OFDM sub-carrier signals,
- 10 reading-out of the memory the data symbols for the OFDM sub-carriers to effect the mapping, the read-out being in a different order than the read-in, the order being determined from a set of addresses, with the effect that the data symbols are interleaved on the sub-carrier signals,
- generating the set of addresses, an address being generated for each of the input
- 15 symbols for mapping the input data symbol on to one of the sub-carrier signals, the generating the set of addresses comprising
- using a linear feedback shift register including a predetermined number of register stages to generate a pseudo-random bit sequence in accordance with a generator polynomial,
- 20 using a permutation circuit operable to receive the content of the shift register stages to permute the order of the bits present in the register stages in accordance with a permutation code to form an address, and
- re-generating an address when a generated address exceeds a predetermined maximum valid address, wherein
- 25 the predetermined maximum valid address is approximately four thousand,
- the linear feedback shift register has eleven register stages with a generator polynomial for the linear feedback shift register of $R'_i[10] = R'_{i-1}[0] \oplus R'_{i-1}[2]$, and the permutation code forms, with an additional bit, a twelve bit address, characterised by
- changing the permutation code, which permutes the order of the bits of the
- 30 register stages to form the set of addresses from one OFDM symbol to another.

11. A method according to clause 10, wherein the changing the permutation code includes cycling through a sequence of different permutation codes for successive OFDM symbols.

5 12. A method according to clause 11, wherein one of the sequence of different permutation codes forms the twelve bit address $R_i[n]$ for the i-th data symbol from the bit present in the n-th register stage $R'_i[n]$ in accordance with the permutation code is defined by the table:

| | | | | | | | | | | | |
|-------------------|----|----|---|---|---|---|---|---|---|---|---|
| $R'_i[n]$ for n = | 10 | 9 | 8 | 7 | 6 | 5 | 4 | 3 | 2 | 1 | 0 |
| $R_i[n]$ for n = | 7 | 10 | 5 | 8 | 1 | 2 | 4 | 9 | 0 | 3 | 6 |

10 13. A method according to clause 11 or 12, wherein the sequence of permutation codes comprises two permutation codes, which are:

| | | | | | | | | | | | |
|-------------------|----|----|---|---|---|---|---|---|---|---|---|
| $R'_i[n]$ for n = | 10 | 9 | 8 | 7 | 6 | 5 | 4 | 3 | 2 | 1 | 0 |
| $R_i[n]$ for n = | 7 | 10 | 5 | 8 | 1 | 2 | 4 | 9 | 0 | 3 | 6 |

and

| | | | | | | | | | | | |
|-------------------|----|---|---|----|---|---|---|---|---|---|---|
| $R'_i[n]$ for n = | 10 | 9 | 8 | 7 | 6 | 5 | 4 | 3 | 2 | 1 | 0 |
| $R_i[n]$ for n = | 6 | 2 | 7 | 10 | 8 | 0 | 3 | 4 | 1 | 9 | 5 |

15 14. A method according to any of clauses 10 to 13, wherein the predetermined maximum valid address is a value substantially between two thousand and four thousand and ninety six.

15 15. A method according to clause 14, wherein the OFDM symbol includes pilot sub-carriers, which are arranged to carry known symbols, and the predetermined maximum valid address depends on a number of the pilot sub-carrier symbols present in the OFDM symbol.

20 16. A method according to any of clauses 10 to 15, wherein the approximately four thousand sub-carriers is provided by one of a plurality of operating modes in which the approximately four thousand sub-carriers provide half or less than half a maximum number of sub-carriers in the OFDM symbols of any of the operating modes, the method comprising

dividing the input data symbols include first sets of input data symbols for mapping onto first OFDM symbols and second sets of input data symbols for mapping onto second OFDM symbols, and

5 interleaving the input data symbols from both first and second sets in accordance with an odd interleaving process comprising

writing the first sets of input data symbols into a first part of the interleaver memory in accordance with a sequential order of the first sets of input data symbols,

10 reading out the first sets of input data symbols from the first part of the interleaver memory on to the sub-carrier signals of the first OFDM symbols in accordance with an order defined by the set of addresses generated with one of the permutation codes of the sequence,

writing the second set of input data symbols into a second part of the interleaver memory in accordance with a sequential order of the second sets of input data symbols, and

15 reading out the second sets of input data symbols from the second part of the interleaver memory on to the sub-carrier signals of the second OFDM symbols in accordance with an order defined by the set of addresses generated with another of the permutation codes of the sequence.

17. A method of transmitting data symbols via a predetermined number of sub-carrier signals of an Orthogonal Frequency Division Multiplexed (OFDM) symbol, the method comprising

reading-into a memory the predetermined number of data symbols for mapping onto the OFDM sub-carrier signals,

25 reading-out of the memory the data symbols for transmission on the OFDM sub-carriers to effect the mapping, the read-out being in a different order than the read-in, the order being determined from a set of addresses, with the effect that the data symbols are interleaved on the sub-carrier signals,

30 generating the set of addresses, an address being generated for each of the input symbols for mapping on to one of the sub-carrier signals, the generating the set of addresses comprising

using a linear feedback shift register including a predetermined number of register stages to generate a pseudo-random bit sequence in accordance with a generator polynomial,

5 using a permutation circuit operable to receive the content of the shift register stages to permute the order of the bits present in the register stages in accordance with a permutation code to form an address, and

re-generating an address when a generated address exceeds a predetermined maximum valid address, wherein

the predetermined maximum valid address is approximately four thousand,

10 the linear feedback shift register has eleven register stages with a generator polynomial for the linear feedback shift register of $R'_i[10] = R'_{i-1}[0] \oplus R'_{i-1}[2]$, and the permutation code forms, with an additional bit, a twelve bit address, characterised by

changing the permutation code, which permutes the order of the bits of the register stages to form the set of addresses from one OFDM symbol to another.

15 18. A method of transmitting according to clause 17, wherein the transmitting includes transmitting in accordance with a Digital Video Broadcasting standard such as the Digital Video Broadcasting-Terrestrial, Digital Video Broadcasting-Handheld standard or the Digital Video Broadcasting-Terrestrial2 standard.

20 19. An address generator for use with transmission of data symbols interleaved onto sub-carriers of an Orthogonal Frequency Division Multiplexed symbol, the address generator being operable to generate a set of addresses, each address being generated for each of the data symbols for mapping the data symbols on to one of the sub-carrier signals, the address generator comprising

25 a linear feedback shift register including a predetermined number of register stages and being operable to generate a pseudo-random bit sequence in accordance with a generator polynomial,

a permutation circuit operable to receive the content of the shift register stages and to permute the order of the bits present in the register stages in accordance with a permutation code to form an address, and

30

a control unit operable in combination with an address check circuit to regenerate an address when a generated address exceeds a predetermined maximum valid address, wherein

the predetermined maximum valid address is approximately four thousand,

- 5 the linear feedback shift register has eleven register stages with a generator polynomial for the linear feedback shift register of $R_i'[10] = R_{i-1}'[0] \oplus R_{i-1}'[2]$, and the permutation order forms, with an additional bit, a twelve bit address, characterised in that

10 the permutation circuit is arranged to change the permutation code, which permutes the order of the bits of the register stages to form the set of addresses from one OFDM symbol to another.

20. An address generator according to clause 19, wherein the permutation circuit is operable to cycle through a sequence of different permutation codes for successive OFDM symbols.

- 15 21. An address generator according to clause 20, wherein one of the sequence of different permutation codes forms the twelve bit address $R_i[n]$ for the i-th data symbol from the bit present in the n-th register stage $R_i'[n]$ in accordance with the permutation code is defined by the table:

| | | | | | | | | | | | |
|-------------------|----|----|---|---|---|---|---|---|---|---|---|
| $R_i'[n]$ for n = | 10 | 9 | 8 | 7 | 6 | 5 | 4 | 3 | 2 | 1 | 0 |
| $R_i[n]$ for n = | 7 | 10 | 5 | 8 | 1 | 2 | 4 | 9 | 0 | 3 | 6 |

- 20 22. An address generator according to clause 20 or 21, wherein the sequence of permutation codes comprises two permutation codes, which are:

| | | | | | | | | | | | |
|-------------------|----|----|---|---|---|---|---|---|---|---|---|
| $R_i'[n]$ for n = | 10 | 9 | 8 | 7 | 6 | 5 | 4 | 3 | 2 | 1 | 0 |
| $R_i[n]$ for n = | 7 | 10 | 5 | 8 | 1 | 2 | 4 | 9 | 0 | 3 | 6 |

and

| | | | | | | | | | | | |
|-------------------|----|---|---|----|---|---|---|---|---|---|---|
| $R_i'[n]$ for n = | 10 | 9 | 8 | 7 | 6 | 5 | 4 | 3 | 2 | 1 | 0 |
| $R_i[n]$ for n = | 6 | 2 | 7 | 10 | 8 | 0 | 3 | 4 | 1 | 9 | 5 |

CLAIMS

1. A data processing apparatus operable to map input data symbols to be communicated onto a predetermined number of sub-carrier signals of Orthogonal Frequency Division Multiplexed OFDM symbols, the predetermined number of sub-carrier signals being determined in accordance with one of a plurality of operating modes and the input data symbols including first sets of input data symbols for mapping onto first OFDM symbols and second sets of input data symbols for mapping onto second OFDM symbols, the data processing apparatus comprising
- 5 an interleaver operable to read-into a memory the predetermined number of data symbols for mapping onto the OFDM sub-carrier signals, and to read-out of the memory the data symbols for the OFDM sub-carriers to effect the mapping, the read-out being in a different order than the read-in, the order being determined from a set of addresses, with the effect that the data symbols are interleaved on the sub-carrier signals,
- 10 an address generator operable to generate the set of addresses, an address being generated for each of the input symbols for mapping the input data symbols onto one of the sub-carrier signals, the address generator comprising
- a linear feedback shift register including a predetermined number of register stages and being operable to generate a pseudo-random bit sequence in accordance with a generator polynomial,
- 20 a permutation circuit operable to receive the content of the shift register stages and to permute the order of the bits present in the register stages in accordance with a permutation code to form an address of one of the OFDM sub-carriers, and
- a control unit operable in combination with an address check circuit to regenerate an address when a generated address exceeds a predetermined maximum valid address, wherein one of a plurality of operating modes provides approximately four thousand sub-carriers per OFDM symbol, the approximately four thousand sub-carriers providing half or less than half a maximum number of sub-carriers in the OFDM symbols of any of the operating modes,
- 25 the predetermined maximum valid address is approximately four thousand,
- 30

the linear feedback shift register has eleven register stages with a generator polynomial for the linear feedback shift register of $R_i[10] = R_{i-1}[0] \oplus R_{i-1}[2]$, and the permutation code forms, with an additional bit, a twelve bit address, and the data processing apparatus is adapted to interleave the input data symbols from both first and second sets in accordance with an odd interleaving process,

the odd interleaving process including

writing the first sets of input data symbols into a first part of the interleaver memory in accordance with a sequential order of the first sets of input data symbols,

reading out the first sets of input data symbols from the first part of the interleaver memory on to the sub-carrier signals of the first OFDM symbols in accordance with an order defined by the set of addresses,

writing the second set of input data symbols into a second part of the interleaver memory in accordance with a sequential order of the second sets of input data symbols, and

reading out the second sets of input data symbols from the second part of the interleaver memory on to the sub-carrier signals of the second OFDM symbols in accordance with an order defined by the set of addresses.

2. A data processing apparatus as claimed in Claim 1, wherein the permutation code forms the twelve bit address $R_i[n]$ for the i-th data symbol from the bit present in the n-th register stage $R_i[n]$ in accordance with the permutation code defined by the table:

| | | | | | | | | | | | |
|------------------|----|----|---|---|---|---|---|---|---|---|---|
| $R_i[n]$ for n = | 10 | 9 | 8 | 7 | 6 | 5 | 4 | 3 | 2 | 1 | 0 |
| $R_i[n]$ for n = | 7 | 10 | 5 | 8 | 1 | 2 | 4 | 9 | 0 | 3 | 6 |

3. A method of mapping input data symbols to be communicated onto a predetermined number of sub-carrier signals of Orthogonal Frequency Division Multiplexed OFDM symbols, the predetermined number of sub-carrier signals being determined in accordance with one of a plurality of operating modes and the input data symbols including first sets of input data symbols for mapping onto first OFDM

symbols and second sets of input data symbols for second OFDM symbols, the method comprising

reading-into a memory the predetermined number of data symbols for mapping onto the OFDM sub-carrier signals,

5 reading-out of the memory the data symbols for the OFDM sub-carriers to effect the mapping, the read-out being in a different order than the read-in, the order being determined from a set of addresses, with the effect that the data symbols are interleaved on the sub-carrier signals,

generating the set of addresses, an address being generated for each of the input
10 symbols for mapping the input data symbol onto one of the sub-carrier signals, the generating the set of addresses comprising

using a linear feedback shift register including a predetermined number of register stages to generate a pseudo-random bit sequence in accordance with a generator polynomial,

15 using a permutation circuit operable to receive the content of the shift register stages to permute the order of the bits present in the register stages in accordance with a permutation code to form an address, and

re-generating an address when a generated address exceeds a predetermined maximum valid address, wherein one of a plurality of operating modes provide
20 approximately four thousand sub-carriers, the approximately four thousand sub-carriers providing half or less than half a maximum number of sub-carriers in the OFDM symbols of any of the operating modes,

the predetermined maximum valid address is approximately four thousand,

the linear feedback shift register has eleven register stages with a generator
25 polynomial for the linear feedback shift register of $R'_i[10] = R'_{i-1}[0] \oplus R'_{i-1}[2]$, and the permutation code forms, with an additional bit, a twelve bit address, and

interleaving the input data symbols from both first and second sets in accordance with an odd interleaving process comprising

30 writing the first sets of input data symbols into a first part of the interleaver memory in accordance with a sequential order of the first sets of input data symbols,

reading out the first sets of input data symbols from the first part of the interleaver memory on to the sub-carrier signals of the first OFDM symbols in accordance with an order defined by the set of addresses,

5 writing the second set of input data symbols into a second part of the interleaver memory in accordance with a sequential order of the second sets of input data symbols, and

reading out the second sets of input data symbols from the second part of the interleaver memory on to the sub-carrier signals of the second OFDM symbols in accordance with an order defined by the set of addresses.

10

4. A method as claimed in Claim 3, wherein the permutation code forms the twelve bit address $R_i[n]$ for the i -th data symbol from the bit present in the n -th register stage $R_i'[n]$ in accordance with the permutation code is defined by the table:

| | | | | | | | | | | | |
|---------------------|----|----|---|---|---|---|---|---|---|---|---|
| $R_i'[n]$ for $n =$ | 10 | 9 | 8 | 7 | 6 | 5 | 4 | 3 | 2 | 1 | 0 |
| $R_i[n]$ for $n =$ | 7 | 10 | 5 | 8 | 1 | 2 | 4 | 9 | 0 | 3 | 6 |

15

5. An address generator configured to generate addresses for reading data symbols into or out of an interleaver memory so that the data symbols are interleaved for transmission onto sub-carriers of Orthogonal Frequency Division Multiplexed symbols, the address generator being operable to generate a set of addresses, each address being generated for each of the data symbols for mapping the data symbols on to a predetermined number of sub-carrier signals of the OFDM symbols, the number of sub-carriers being determined in accordance with one of a plurality of operating modes and the input data symbols including first sets of input data symbols for mapping onto first OFDM symbols and second sets of input data symbols for second OFDM symbols, the address generator comprising

20

25 a linear feedback shift register including a predetermined number of register stages and being operable to generate a pseudo-random bit sequence in accordance with a generator polynomial,

a permutation circuit operable to receive the content of the shift register stages and to permute the order of the bits present in the register stages in accordance with a permutation code to form an address, and

5 a control unit operable in combination with an address check circuit to regenerate an address when a generated address exceeds a predetermined maximum valid address, wherein

one of a plurality of operating modes provides approximately four thousand sub-carriers per OFDM symbol, the approximately four thousand sub-carriers providing half or less than half a maximum number of sub-carriers in the OFDM symbols of any of the operating modes,

10 the predetermined maximum valid address is approximately four thousand,

the linear feedback shift register has eleven register stages with a generator polynomial for the linear feedback shift register of $R_i'[10] = R_{i-1}'[0] \oplus R_{i-1}'[2]$, and the permutation code forms, with an additional bit, a twelve bit address, and the address generator is arranged in use to generate addresses to interleave first and second sets of the input data symbols onto the OFDM symbols in accordance with an odd interleaving process,

the odd interleaving process including

15 writing the first sets of input data symbols into a first part of the interleaver memory in accordance with a sequential order of the first sets of input data symbols,

reading out the first sets of input data symbols from the first part of the interleaver memory on to the sub-carrier signals of the first OFDM symbols in accordance with an order defined by the set of addresses,

25 writing the second set of input data symbols into a second part of the interleaver memory in accordance with a sequential order of the second sets of input data symbols, and

reading out the second sets of input data symbols from the second part of the interleaver memory on to the sub-carrier signals of the second OFDM symbols in accordance with an order defined by the set of addresses.

6. An address generator as claimed in Claim 5, wherein the permutation code forms the twelve bit address $R_i[n]$ for the i -th data symbol from the bit present in the n -th register stage $R_i[n]$ in accordance with the permutation code defined by the table:

| | | | | | | | | | | | |
|--------------------|----|----|---|---|---|---|---|---|---|---|---|
| $R_i[n]$ for $n =$ | 10 | 9 | 8 | 7 | 6 | 5 | 4 | 3 | 2 | 1 | 0 |
| $R_i[n]$ for $n =$ | 7 | 10 | 5 | 8 | 1 | 2 | 4 | 9 | 0 | 3 | 6 |

5

7. A transmitter for transmitting input data symbols using Orthogonal Frequency Division Multiplexing (OFDM), the transmitter including a data processing apparatus for mapping the input data symbols on a predetermined number of sub-carrier signals of OFDM symbols, the data processing apparatus comprising

10 an interleaver operable to read-into a memory the predetermined number of data symbols for mapping onto the OFDM sub-carrier signals, and to read-out of the memory the data symbols for the OFDM sub-carriers to effect the mapping, the read-out being in a different order than the read-in, the order being determined from a set of addresses, with the effect that the data symbols are interleaved on the sub-carrier signals,

15

an address generator operable to generate the set of addresses, an address being generated for each of the input symbols for mapping on to one of the sub-carrier signals, the address generator comprising

20 a linear feedback shift register including a predetermined number of register stages and being operable to generate a pseudo-random bit sequence in accordance with a generator polynomial,

a permutation circuit operable to receive the content of the shift register stages and to permute the order of the bits present in the register stages in accordance with a permutation code to form an address, and

25 a control unit operable in combination with an address check circuit to regenerate an address when a generated address exceeds a predetermined maximum valid address, wherein

one of a plurality of operating modes provides approximately four thousand sub-carriers per OFDM symbol, the approximately four thousand sub-carriers

providing half or less than half a maximum number of sub-carriers in the OFDM symbols of any of the operating modes,

the predetermined maximum valid address is approximately four thousand,

the linear feedback shift register has eleven register stages with a generator polynomial for the linear feedback shift register of $R_i[10] = R_{i-1}[0] \oplus R_{i-1}[2]$, and the permutation code forms, with an additional bit, a twelve bit address, and the data processing apparatus is adapted to interleave the input data symbols from both first and second sets in accordance with an odd interleaving process,

the odd interleaving process including

10 writing the first sets of input data symbols into a first part of the interleaver memory in accordance with a sequential order of the first sets of input data symbols,

reading out the first sets of input data symbols from the first part of the interleaver memory on to the sub-carrier signals of the first OFDM symbols in accordance with an order defined by the set of addresses,

15 writing the second set of input data symbols into a second part of the interleaver memory in accordance with a sequential order of the second sets of input data symbols, and

reading out the second sets of input data symbols from the second part of the interleaver memory on to the sub-carrier signals of the second OFDM symbols in accordance with an order defined by the set of addresses.

8. A transmitter as claimed in Claim 7, wherein the permutation code forms the twelve bit address $R_i[n]$ for the i-th data symbol from the bit present in the n-th register stage $R_i[n]$ in accordance with the permutation code defined by the table:

| | | | | | | | | | | | |
|------------------|----|----|---|---|---|---|---|---|---|---|---|
| $R_i[n]$ for n = | 10 | 9 | 8 | 7 | 6 | 5 | 4 | 3 | 2 | 1 | 0 |
| $R_i[n]$ for n = | 7 | 10 | 5 | 8 | 1 | 2 | 4 | 9 | 0 | 3 | 6 |

25

9. A transmitter as claimed in Claim 7 or 8, wherein the transmitter is operable to transmit data in accordance with a Digital Video Broadcasting standard

such as the Digital Video Broadcasting-Terrestrial, Digital Video Broadcasting-Handheld standard or the Digital Video Broadcasting-Terrestrial2 standard.

10. A method of transmitting data symbols via a predetermined number of
 5 sub-carrier signals of an Orthogonal Frequency Division Multiplexed (OFDM)
 symbol, the method comprising
- reading-into a memory the predetermined number of data symbols for mapping
 onto the OFDM sub-carrier signals,
 - reading-out of the memory the data symbols for transmission on the OFDM
 10 sub-carriers to effect the mapping, the read-out being in a different order than the read-
 in, the order being determined from a set of addresses, with the effect that the data
 symbols are interleaved on the sub-carrier signals,
 - generating the set of addresses, an address being generated for each of the input
 symbols for mapping on to one of the sub-carrier signals, the generating the set of
 15 addresses comprising
 - using a linear feedback shift register including a predetermined number of
 register stages to generate a pseudo-random bit sequence in accordance with a
 generator polynomial,
 - using a permutation circuit operable to receive the content of the shift register
 20 stages to permute the order of the bits present in the register stages in accordance with
 a permutation code to form an address, and
 - re-generating an address when a generated address exceeds a predetermined
 maximum valid address, wherein
 - wherein one of a plurality of operating modes provide approximately four
 25 thousand sub-carriers, the approximately four thousand sub-carriers providing half or
 less than half a maximum number of sub-carriers in the OFDM symbols of any of the
 operating modes,
 - the predetermined maximum valid address is approximately four thousand,
 - the linear feedback shift register has eleven register stages with a generator
 30 polynomial for the linear feedback shift register of $R_i[10] = R_{i-1}[0] \oplus R_{i-1}[2]$, and the
 permutation code forms, with an additional bit, a twelve bit address, and

interleaving the input data symbols from both first and second sets in accordance with an odd interleaving process comprising

writing the first sets of input data symbols into a first part of the interleaver memory in accordance with a sequential order of the first sets of input data symbols,

5 reading out the first sets of input data symbols from the first part of the interleaver memory on to the sub-carrier signals of the first OFDM symbols in accordance with an order defined by the set of addresses,

writing the second set of input data symbols into a second part of the interleaver memory in accordance with a sequential order of the second sets of input data symbols, and

10 reading out the second sets of input data symbols from the second part of the interleaver memory on to the sub-carrier signals of the second OFDM symbols in accordance with an order defined by the set of addresses.

15 11. A method as claimed in Claim 10, wherein the permutation code forms the twelve bit address $R_i[n]$ for the i -th data symbol from the bit present in the n -th register stage $R_i[n]$ in accordance with the permutation code is defined by the table:

| | | | | | | | | | | | |
|--------------------|----|----|---|---|---|---|---|---|---|---|---|
| $R_i[n]$ for $n =$ | 10 | 9 | 8 | 7 | 6 | 5 | 4 | 3 | 2 | 1 | 0 |
| $R_i[n]$ for $n =$ | 7 | 10 | 5 | 8 | 1 | 2 | 4 | 9 | 0 | 3 | 6 |

20 12. A method of transmitting as claimed in Claim 10 or 11, wherein the transmitting includes transmitting in accordance with a Digital Video Broadcasting standard such as the Digital Video Broadcasting-Terrestrial, Digital Video Broadcasting-Handheld standard or the Digital Video Broadcasting-Terrestrial2 standard.

25

13. A data processing apparatus and a transmitter substantially as herein before described with reference to the accompanying drawings.

14. A method of mapping input symbols to be communicated onto a predetermined number of sub-carrier signals of an Orthogonal Frequency Division Multiplexed OFDM symbol and a method of transmitting substantially as herein before described with reference to the accompanying drawings.

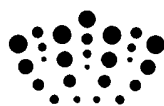

Application No: GB0920375.3

Examiner: Robert Barrell

Claims searched: 1-14

Date of search: 15 December 2009

Patents Act 1977: Search Report under Section 17

Documents considered to be relevant:

| Category | Relevant to claims | Identity of document and passage or figure of particular relevance |
|----------|--------------------|--|
| A | - | EP1463255 A1 (SONY) See: the whole document |
| A | - | EP1463256 A1 (SONY) See: the whole document |

Categories:

| | | | |
|---|---|---|--|
| X | Document indicating lack of novelty or inventive step | A | Document indicating technological background and/or state of the art. |
| Y | Document indicating lack of inventive step if combined with one or more other documents of same category. | P | Document published on or after the declared priority date but before the filing date of this invention. |
| & | Member of the same patent family | E | Patent document published on or after, but with priority date earlier than, the filing date of this application. |

Field of Search:

Search of GB, EP, WO & US patent documents classified in the following areas of the UKC^X:

| |
|--|
| |
|--|

Worldwide search of patent documents classified in the following areas of the IPC

| |
|------------------|
| G06F; H03M; H04N |
|------------------|

The following online and other databases have been used in the preparation of this search report

| |
|-------------|
| EPODOC, WPI |
|-------------|

International Classification:

| Subclass | Subgroup | Valid From |
|----------|----------|------------|
| H03M | 0013/27 | 01/01/2006 |
| H04L | 0027/26 | 01/01/2006 |
| G06F | 0007/58 | 01/01/2006 |
| H04N | 0007/24 | 01/01/2006 |