



INTERNATIONAL APPLICATION PUBLISHED UNDER THE PATENT COOPERATION TREATY (PCT)

(51) International Patent Classification ⁷ : H04Q 7/22	A2	(11) International Publication Number: WO 00/21316 (43) International Publication Date: 13 April 2000 (13.04.00)
(21) International Application Number: PCT/US99/23215 (22) International Filing Date: 6 October 1999 (06.10.99) (30) Priority Data: 09/166,793 6 October 1998 (06.10.98) US (71) Applicant: ERICSSON INC. [US/US]; 7001 Development Drive, P.O. Box 13969, Research Triangle Park, CA 27709 (US). (72) Inventors: CHENNAKESHU, Sandeep; 311 Glen Abbey Drive, Cary, NC 27513 (US). RYDBECK, Nils; 207 Queensferry Road, Cary, NC 27511 (US). HASSAN, Amer, A.; 12623 N.E. 107th Place, Kirkland, WA 98033 (US). DENT, Paul, W.; 637 Eagle Point Road, Pittsboro, NC 27312 (US). (74) Agents: GRUDZIECKI, Ronald, L. et al.; Burns, Doane, Swecker & Mathis LLP, P.O. Box 1404, Alexandria, VA 22313-1404 (US).	(81) Designated States: AE, AL, AM, AT, AU, AZ, BA, BB, BG, BR, BY, CA, CH, CN, CR, CU, CZ, DE, DK, DM, EE, ES, FI, GB, GD, GE, GH, GM, HR, HU, ID, IL, IN, IS, JP, KE, KG, KP, KR, KZ, LC, LK, LR, LS, LT, LU, LV, MD, MG, MK, MN, MW, MX, NO, NZ, PL, PT, RO, RU, SD, SE, SG, SI, SK, SL, TJ, TM, TR, TT, TZ, UA, UG, UZ, VN, YU, ZA, ZW, ARIPO patent (GH, GM, KE, LS, MW, SD, SL, SZ, TZ, UG, ZW), Eurasian patent (AM, AZ, BY, KG, KZ, MD, RU, TJ, TM), European patent (AT, BE, CH, CY, DE, DK, ES, FI, FR, GB, GR, IE, IT, LU, MC, NL, PT, SE), OAPI patent (BF, BJ, CF, CG, CI, CM, GA, GN, GW, ML, MR, NE, SN, TD, TG). Published <i>Without international search report and to be republished upon receipt of that report.</i>	
(54) Title: HIGH POWER SHORT MESSAGE SERVICE USING TDMA FRAMES AND/OR BROADCAST CONTROL CHANNEL		
(57) Abstract A method and system for transmitting short data messages in a control station-based TDMA radiocommunication system. Selected TDMA frames are assigned as message frames, and one or more data slots from each message frame are assigned to transmitter/receivers. Data messages can be encoded and transmitted multiple times, at an increased power level, from a control station to a transmitter/receiver over the appropriate data slots in each message frame. The selected TDMA frames are preferably slow associated control channel frames. Also, short alphanumeric messages can be transmitted over the broadcast control channel of a digital radiocommunication link, or another communication channel consisting of one or more slots from successive frames in a TDMA communication link. An increase in transmission power is used in combination with repetition to increase effective signal margin without complications in the mobile unit design, significant delay, or co-channel interference. Where a more significant increase in signal margin is desired, when a longer message is required, or for voice messages, the message may be stored and the mobile unit alerted of the messages.		

FOR THE PURPOSES OF INFORMATION ONLY

Codes used to identify States party to the PCT on the front pages of pamphlets publishing international applications under the PCT.

AL	Albania	ES	Spain	LS	Lesotho	SI	Slovenia
AM	Armenia	FI	Finland	LT	Lithuania	SK	Slovakia
AT	Austria	FR	France	LU	Luxembourg	SN	Senegal
AU	Australia	GA	Gabon	LV	Latvia	SZ	Swaziland
AZ	Azerbaijan	GB	United Kingdom	MC	Monaco	TD	Chad
BA	Bosnia and Herzegovina	GE	Georgia	MD	Republic of Moldova	TG	Togo
BB	Barbados	GH	Ghana	MG	Madagascar	TJ	Tajikistan
BE	Belgium	GN	Guinea	MK	The former Yugoslav Republic of Macedonia	TM	Turkmenistan
BF	Burkina Faso	GR	Greece	ML	Mali	TR	Turkey
BG	Bulgaria	HU	Hungary	MN	Mongolia	TT	Trinidad and Tobago
BJ	Benin	IE	Ireland	MR	Mauritania	UA	Ukraine
BR	Brazil	IL	Israel	MW	Malawi	UG	Uganda
BY	Belarus	IS	Iceland	MX	Mexico	US	United States of America
CA	Canada	IT	Italy	NE	Niger	UZ	Uzbekistan
CF	Central African Republic	JP	Japan	NL	Netherlands	VN	Viet Nam
CG	Congo	KE	Kenya	NO	Norway	YU	Yugoslavia
CH	Switzerland	KG	Kyrgyzstan	NZ	New Zealand	ZW	Zimbabwe
CI	Côte d'Ivoire	KP	Democratic People's Republic of Korea	PL	Poland		
CM	Cameroon	KR	Republic of Korea	PT	Portugal		
CN	China	KZ	Kazakstan	RO	Romania		
CU	Cuba	LC	Saint Lucia	RU	Russian Federation		
CZ	Czech Republic	LI	Liechtenstein	SD	Sudan		
DE	Germany	LK	Sri Lanka	SE	Sweden		
DK	Denmark	LR	Liberia	SG	Singapore		
EE	Estonia						

**HIGH POWER SHORT MESSAGE SERVICE USING TDMA FRAMES
AND/OR BROADCAST CONTROL CHANNEL**

5

Technical Field

The present invention generally relates to radiocommunication systems and more particularly relates to a system and method for reliably transmitting
10 alphanumeric messages via radiocommunication signals under non-ideal conditions.

Background

Referring to FIG. 1, a typical cellular mobile radiocommunication system is shown. The typical system includes a number of base stations similar to base station 110 and a number of mobile units or stations similar to mobile 120. Voice and/or
15 data communication can be performed using these devices or their equivalents. The base station includes a control and processing unit 130 which is connected to the MSC (mobile switching center) 140 which in turn is connected to the public switched telephone network (not shown).

The base station 110 serves a cell and includes a plurality of voice channels
20 handled by voice channel transceiver 150 which is controlled by the control and processing unit 130. Also, each base station includes a control channel transceiver 160 which may be capable of handling more than one control channel. The control channel transceiver 160 is controlled by the control and processing unit 130. The control channel transceiver 160 broadcasts control information over the control
25 channel of the base station or cell to mobiles locked to that control channel. The

-2-

voice channel transceiver broadcasts the traffic or voice channels which can include digital control channel location information.

When the mobile 120 first enters an idle mode, it periodically scans the control channels of base stations like base station 110 for the presence of a paging burst addressed to the mobile 120. The paging burst informs mobile 120 which cell to lock on or camp to. The mobile 120 receives the absolute and relative information broadcast on a control channel at its voice and control channel transceiver 170. Then, the processing unit 180 evaluates the received control channel information which includes the characteristics of the candidate cells and determines which cell the mobile should lock to. The received control channel information not only includes absolute information concerning the cell with which it is associated, but also contains relative information concerning other cells proximate to the cell with which the control channel is associated. These adjacent cells are periodically scanned while monitoring the primary control channel to determine if there is a more suitable candidate. Additional information relating to specifics of mobile and base station implementations can be found in U.S. Patent Application Serial No. 07/967,027 entitled "Multi-Mode Signal Processing" filed on October 27, 1992 to P. Dent and B. Ekelund, the entirety of which is incorporated herein by reference. It will be appreciated that the base station may be replaced by one or more satellites in a satellite-based mobile radiocommunication system.

To increase radiocommunication system capacity, digital communication and multiple access techniques such as Frequency Division Multiple Access (FDMA), Time Division Multiple Access (TDMA), and Code Division Multiple Access (CDMA) may be used. The objective of each of these multiple access techniques is to combine signals from different sources onto a common transmission medium in such a way that, at their destinations, the different channels can be separated without mutual interference. In a FDMA system, users share the radio spectrum in the frequency domain. Each user is allocated a part of the frequency band which is used

-3-

throughout a conversation. In a TDMA system, users share the radio spectrum in the time domain. Each radio channel or carrier frequency is divided into a series of time slots, and individual users are allocated a time slot during which the user has access to the entire frequency band allocated for the system (wideband TDMA) or only a part of the band (narrowband TDMA). Each time slot contains a "burst" of information from a data source, e.g., a digitally encoded portion of a voice conversation. The time slots are grouped into successive TDMA frames having a predetermined duration. The number of time slots in each TDMA frame is related to the number of different users that can simultaneously share the radio channel. If each slot in a TDMA frame is assigned to a different user, the duration of a TDMA frame is the minimum amount of time between successive time slots assigned to the same user. In a CDMA system, each user is assigned a unique pseudorandom user code to uniquely access the frequency time domain. Examples of CDMA techniques include spread spectrum and frequency hopping.

In a TDMA system, the successive time slots assigned to the same user, which are usually not consecutive time slots on the radio carrier, constitute the user's digital traffic channel, which is considered to be a logical channel assigned to the user. The organization of TDMA channels, using the GSM standard as an example, is shown in FIG. 2. The TDMA channels include traffic channels TCH and signalling channels SC. The TCH channels include full-rate and half-rate channels for transmitting voice and/or data signals. The signalling channels SC transfer signalling information between the mobile unit and the satellite (or base station). The signalling channels SC include three types of control channels: broadcast control channels (BCCHs), common control channels (CCCHs) shared between multiple subscribers, and dedicated control channels (DCCHs) assigned to a single subscriber. A BCCH typically includes a frequency correction channel (FCH) and a synchronization channel (SCH), both of which are downlink channels. The common control channels (CCCHs) include downlink paging (PCH) and access grant (AGCH) channels, as well

as the uplink random access channel (RACH). The dedicated control channels DCCH include a fast associated control channel (FACCH), a slow associated control channel (SACCH), and a standalone dedicated control channel (SDCCH). The slow associated control channel is assigned to a traffic (voice or data) channel or to a standalone dedicated control channel (SDCCH). The SACCH channel provides power and frame adjustment and control information to the mobile unit.

The frequency correction channel FCH of the broadcast control channel carries information which allows the mobile unit to accurately tune to the base station. The synchronization channel SCH of the broadcast control channel provides frame synchronization data to the mobile unit.

Using a GSM-type system as an example, the slow associated control channel SACCH can be formed by dedicating every 26th TDMA frame to carrying SACCH information. Each SACCH frame includes 8 time slots (1 SACCH slot for each traffic slot in the frame), allowing one unique SACCH channel for each mobile communication link. The base station or satellite sends commands over the SACCH channel to advance or retard the transmission timing of the mobile unit to achieve time alignment between different mobile bursts received at the base station or satellite.

The random access channel RACH is used by the mobiles to request access to the system. The RACH logical channel is a unidirectional uplink channel (from the mobile to the base station or satellite), and is shared by separate mobile units (one RACH per cell is sufficient in typical systems, even during periods of heavy use). Mobile units continuously monitor the status of the RACH channel to determine if the channel is busy or idle. If the RACH channel is idle, a mobile unit desiring access sends its mobile identification number, along with the desired telephone number, on the RACH to the base station or satellite. The MSC receives this information from the base station or satellite and assigns an idle voice channel to the mobile station, and transmits the channel identification to the mobile through the base station or

-5-

satellite so that the mobile station can tune itself to the new channel. All time slots on the RACH uplink channel are used for mobile access requests, either on a contention basis or on a reserved basis. Reserved-basis access is described in U.S. Patent Application No. 08/140,467, entitled "Method of Effecting Random Access in a Mobile Radio System", which was filed on October 25, 1993, and which is incorporated in this application by reference. One important feature of RACH operation is that reception of some downlink information is required, whereby mobile stations receive real-time feedback for every burst they send on the uplink. This is known as Layer 2 ARQ, or automatic repeat request, on the RACH. The downlink information preferably comprises twenty-two bits that may be thought of as another downlink sub-channel dedicated to carrying, in the downlink, Layer 2 information specific to the uplink. This flow of information, which can be called shared channel feedback, enhances the throughput capacity of the RACH so that a mobile station can quickly determine whether any burst of any access attempt has been successfully received. As shown in FIG. 2, this downlink information is transmitted on channel AGCH.

Transmission of signals in a TDMA system occurs in a buffer-and-burst, or discontinuous-transmission, mode: each mobile unit transmits or receives only during its assigned time slots in the TDMA frames on the mobile unit's assigned frequency. At full rate, for example, a mobile station might transmit during slot 1, receive during slot 2, idle during slot 3, transmit during slot 4, receive during slot 5, and idle during slot 6, and then repeat the cycle during succeeding TDMA frames. The mobile unit, which may be battery-powered, can be switched off (or "sleep") to save power during the time slots when it is neither transmitting nor receiving.

To increase mobility and portability, radiocommunication subscribers tend to prefer mobile units having a relatively small, omnidirectional (and accordingly, less powerful) antenna over mobile units having a large or directional antenna. Because of this preference, it is sometimes difficult to provide sufficient signal strength for the

exchange of communication signals between typical mobile units having a small, omnidirectional antenna and a mobile switching center (MSC) or satellite. This problem is particularly serious in satellite-based mobile radiocommunications.

5 A satellite-based mobile radiocommunication system provides radiocommunication services to particular geographical areas of the earth using one or more partially overlapping satellite beams. Each satellite beam has a radius of up to about 1000 KM. Due to the power limitations of a satellite, it is not practical to provide a high link margin in every beam simultaneously.

10 Because mobile satellite links are severely power limited, communication is typically limited to line-of-sight channels with Ricean fading. Ricean fading occurs from a combination of a strong line-of-sight path and a ground-reflected wave, along with weak building-reflected waves. These channels require a communications link margin of approximately 10 dB or more to achieve voice communication in ideal or near-ideal conditions, such as when the mobile radiotelephone unit antenna is properly deployed and the unit is in an unobstructed location. In these near-ideal channels, the mobile unit can successfully monitor the paging channel to detect incoming calls. In non-ideal conditions, such as when the mobile unit antenna is not 15 properly deployed or the mobile unit is in an obstructed location (e.g., inside a building) reflected waves, including ground-reflected and building-reflected waves, become dominant. The channels in these non-ideal conditions are characterized by flat Rayleigh fading (the most severe type of fading) with severe attenuation. In such channels, a link margin of as much as 30 dB or more is required to achieve reliable voice or data communication, and the mobile unit in this case cannot monitor the 20 paging channel to detect incoming calls. In these non-ideal conditions, a short message service (SMS) is desirable. Due to the power limitations of the satellite, SMS is particularly effective when used in non-ideal conditions to alert a mobile station user of an incoming call. The mobile station user may then change locations to receive or return the call. The term "link margin" or "signal margin" refers to the 25

-7-

additional power required to offer adequate service over and above the power required under ideal conditions- that is, a channel having no impairments other than additive white Gaussian noise (AWGN). "Impairments" include fading of signal amplitude, doppler shifts, phase variations, signal shadowing or blockage, implementation losses, and anomalies in the antenna radiation pattern.

Whether transmitting voice or data, it is frequently desirable to increase the signal margin to ensure reliable radiocommunication performance, particularly in power-limited satellite applications. Known methods of increasing the link margin of a signal include expanding the channel bandwidth to achieve frequency selectivity or to use forward error correction coding (such as convolutional coding), increasing signal power, and bit repetition (which may be viewed as a form of forward error correction coding). Each of these methods has significant limitations. Bandwidth expansion is typically achieved by known methods such as signal spreading and low bit rate error correction coding, and results in a signal which is less sensitive to fading. Bandwidth expansion reduces spectrum allocation efficiency. Further, in a SMS application, if the expanded bandwidth of the voice channel is different from (e.g., larger than) the bandwidth of the message channel, two separate and complete radios (one for each service) will be required in the mobile unit, thereby complicating its design. Also, a coherent Rake receiver or equalizer is also typically required to reduce delay spread, further complicating the design of the mobile unit. Bandwidth expansion may also be implemented by repeated transmissions of the entire voice or data message. However, under the non-ideal conditions of interest, this method is not effective because each repetition is typically below the noise floor (that is, does not have a sufficient margin), resulting in a high error rate and preventing the coherent integration of the repetitions.

Increasing signal power may also be used to provide a higher margin. Due to the power limitations of the satellite, this is typically not a practical approach. In addition to increasing the cost of the system, increased transmission power also

5 makes it more difficult to control co-channel interference, particularly in TDMA systems with narrow re-use margins. Accordingly, large power increases from the satellite to the mobile unit may be provided only during periods of relatively light use. Further, because the mobile unit is even more power limited than the satellite, this technique is typically practical only in one direction, from the satellite to the mobile unit.

Bit repetition may also be used to increase the margin. Bit repetition results in a lower error rate than message repetition, particularly in non-ideal conditions. Bit repetition causes transmission delay, which is not desirable for voice signals, for obvious reasons. However, transmission delay may be acceptable for data communications, such as a SMS feature, provided that the delay is kept to a reasonable minimum. Bit repetition is achieved by transmitting individual bits or modulation symbols, or packets of bits or modulation symbols, a plurality of times such that all repetitions are contiguous or contained within the same time slot or slots of successive TDMA frames. The receiver integrates the energy from each repetition to create a signal having a higher margin. As noted above, bit repetition can cause significant delay, depending upon the length of the message. To achieve a 30 dB signal margin, each bit will have to be repeated 1000 times. A typical short message has between 32 and 64 characters in the GSM system, the European digital standard, up to 245 characters in the DAMPS (Digital Advanced Mobile Phone Service, IS-136) system currently used in the United States, and up to 160 characters in the DECT (Digital European Cordless Telephone) system. Assuming a GSM system having TDMA frames of 18.64 ms, with 16 slots per frame and 114 data bits/slot, the minimum delay for receiving a 64 character message, not including propagation time, is as follows:

$$64 \text{ bits} \times 8 \text{ bits/character} \times 1000 \text{ repetitions/bit} \times 18.64 \text{ ms/slot} \times 1/114 \text{ slot/data bit} = 84 \text{ seconds.}$$

Such a delay is highly undesirable, even for data transmission. Accordingly,

it would be desirable for a radiocommunication system to allow for transmission of signals at an increased signal margin without significant delay and without a significant increase in power.

5 It would be further desirable for a communication system to allow for transmission of signals with an increased signal margin without requiring expansion of the channel bandwidth.

It would also be desirable for a TDMA communication system to allow for transmission of signals with an increased signal margin without requiring a change in the structure or organization of TDMA frames.

10 It would be further desirable for a mobile radiocommunication system to allow for transmission of data messages originating from either a mobile unit or from a satellite or base station with an increased signal margin.

15 It would be further desirable for a communication system to selectively increase the signal margin of a communication link for the transmission of data messages.

Summary of the Invention

The above-noted and other limitations of conventional communication systems and methods are overcome by the present invention, which provides for a high-penetration transmission method for transmitting short alphanumeric messages in which signal margin is increased by a combination of bit repetition and a relatively small increase in power. According to exemplary embodiments, the combination of bit or message repetition and a relatively small increase in power avoids the unacceptable delays characteristic of systems which rely solely on repetition to increase the signal margin. Likewise, the combination of repetition and a relatively small increase in power avoids the co-channel interference problems of systems which rely solely on increased power to increase the signal margin.

20
25

According to one exemplary embodiment of the present invention, a

-10-

radiocommunication system is provided with a short message service feature for transmitting alphanumeric messages between a control station, such as a satellite, and a transmitter/receiver, such as a mobile unit. Selected ones of the TDMA frames are assigned as message frames, and each message frame includes a number of data slots
5 for transmitting data messages. In order to ensure reliable transmission over channels having severe attenuation, the data message is encoded; the encoded message is divided into packets or groups of one or more bits each; each packet is transmitted, at a power level greater than the power level for voice transmission, multiple times
10 over the data slots of the message frames, using the same time slot or slots for each transmission to a particular subscriber; and the transmissions are integrated and checked for errors at the receiver to form a signal having an increased margin.

According to another exemplary embodiment of the present invention, a radiocommunication system is provided with a short message service feature for transmitting alphanumeric messages to and from a mobile unit. In order to ensure
15 reliable transmission over channels having severe attenuation, the short message is encoded with error detection coding to form one or more data codewords; each codeword is transmitted multiple times over a message channel having message frames. Each message frame is made up of time slots from each TDMA frame or each set of TDMA frames. The message channel is transmitted at a power level
20 greater than the power level for voice transmission and greater than the power level for control information transmission. The message channel may be formed by slots taken from the broadcast control channel or other suitable channel. The multiple transmissions are integrated and checked for errors at the receiver.

Brief Description of the Drawings

25 The foregoing objects, features and advantages of the present invention will be more readily understood upon reading the following detailed description in conjunction with the drawings in which:

FIG. 1 is a block diagram of an exemplary mobile radiocommunication system;

FIG. 2 is a diagram showing the organization of channels in a typical GSM digital radiocommunication system;

5 FIG. 3 is a diagram of a satellite-based mobile radiocommunication system in which the signal transmission method of the present invention may be implemented;

FIG. 4 is a flow chart describing the transmission of a short message according to an embodiment of the present invention;

10 FIG. 5A is a diagram showing the format of an SMS frame according to an embodiment of the present invention;

FIG. 5B is a diagram showing a burst format of an SMS slot according to an embodiment of the present invention; and

FIG. 6 is a diagram showing a frame format of an SMS service according to an embodiment of the present invention.

15 Detailed Description of the Preferred Embodiments

While the following description is directed toward a short message service implemented in a satellite-based radiocommunication system incorporating satellites and mobile radiocommunication units, it will be appreciated that the present invention may also be applied to other types of communication systems which include suitable
20 transmitter/receiver units.

In a satellite-based mobile radiocommunication system, a communication link for transmitting voice or data may be established between a mobile station and either a standard telephone or a second mobile station through one satellite, multiple satellites, or a combination of one or more satellites and the PSTN (public switched
25 telephone network). Such a system, as shown in FIG. 3, may be desirable to achieve a broad geographical coverage in which few or no base stations are present, and additional base stations are not practical, such as in rural areas. Due to the inherent

-12-

power limitations of satellites, voice communications links between the satellite and the mobile station require ideal or near-ideal conditions; that is, conditions such as line-of-sight communication with the mobile station's antenna properly deployed. In non-ideal conditions, such as when the mobile station is shadowed (e.g., inside a building, etc.) or when the mobile antenna is not properly deployed, the power or signal margin requirements for communication increases significantly due to the increased attenuation in the channel. In such situations (shown as MUz in FIG. 3), Rayleigh fading often prevents satisfactory communication, and it is therefore desirable to send a short alphanumeric message to the mobile station. The message may be used, for example, to inform the subscriber of an incoming call. The present invention ensures reliable transmission of the message by providing for an efficient technique for increasing signal margin without significant delay, power increase, or co-channel interference.

For purposes of illustration only, and without limiting the scope of the invention, a satellite-based GSM radiocommunication system using TDMA channels may be assumed to exhibit the following conditions. The communication channel has no line of sight component and is subject to flat Rayleigh fading with severe attenuation. As will be appreciated by those of skill in the art, Rayleigh (or multipath) fading is a phenomenon which occurs when multipath waves form standing-wave pairs due to reflection from the physical structures in a service area. The standing-wave pairs summed together form an irregular wave fading structure. When the mobile unit is stationary, it receives a constant signal. However, when the mobile unit is moving, the fading structure causes fading to occur which increases as the mobile unit moves faster. The mean signal level of the non-ideal Rayleigh channel is approximately 20-30 dB below the signal level of a near-ideal line-of-sight channel.

In order to ensure reliable transmission of a short message to the mobile unit in non-ideal conditions, the signal margin must be increased. According to the

-13-

present invention, bit repetition and power increase can be combined to provide an increased signal margin without significant delay.

It will be appreciated that decibels (dB) are units used to express ratios of power, current, or voltage. Specifically, a power ratio ($P2/P1$) may be expressed in
5 decibels by the formula $\text{dB} = 10 \log (P2/P1)$. A signal margin of 30 dB requires a power ratio of 1000, since $10 \log 1000 = 30$. Thus, to achieve this signal margin solely by bit repetition, each bit must be repeated 1000 times and the signal margin from each repetition must be integrated at the receiver, resulting in the 82 second delay calculated above. However, to achieve a 15 dB margin, the required power
10 ratio is only 31.623, since $10 \log 31.623 = 15$. Thus, a 30 dB signal margin may be provided by increasing the power by 15 dB and repeating each bit approximately 31 times. Using this technique, the bit-repetition delay for a 64 character message is (64 characters X 8 bits/character X 31 repeats/bit X 18.64 ms/slot X 1/114 slot/bits) approximately 2.5 seconds. As a result, the bit repetition delay is
15 maintained at a reasonable level, and the power increase is also maintained at a reasonable level, thereby avoiding co-channel interference. It will be appreciated that many different combinations of repetitions and power increases are possible to achieve successful communication in Rayleigh fading environments without significant delay. Further, rather than repeating individual bits of a digital signal,
20 groups of bits may be repeated.

To implement the technique of the present invention, the power increase from the satellite to the mobile station may be provided by averaging a power load across multiple users. That is, communication channels used by mobile units in near-ideal conditions might have their power reduced to increase the power supply to a mobile
25 unit or units in the non-ideal conditions. Power increase may also be provided by time averaging, in which individual slots in consecutive TDMA frames are transmitted at an increased power level. It will be appreciated that the power increase from the satellite to the mobile station may also be achieved by other techniques

known in the art.

The power limitations of the mobile unit are even more severe than the power limitations of the satellite. Thus, it is even more difficult to increase power for communication from the mobile to the satellite. Such communication is (or may be) necessary to send a message or acknowledge receipt of a message. According to one embodiment of the present invention, the power increase from the mobile unit to the satellite may be achieved by allowing the mobile unit to transmit on all time slots of the random access channel RACH. Bit or message repetition may also be implemented by the mobile unit to further effectively increase the margin of the signal transmitted to the satellite. Since acknowledgement by the mobile unit over the RACH channel may be accomplished by a signal having a low information rate, a higher number of sync bits and a higher number of bit and message repetitions relative to the forward channel can be used to compensate for the lower transmission power of the mobile unit. Preferably, the mobile unit transmits consecutive repetitions on separate carrier frequencies to decorrelate the repetitions. Because the message is short, the transmission time will be short and the average transmitted power will be acceptable using this system.

Referring now to FIG. 4, a flow chart describing the transmission of a short message using the transmission method of the present invention is shown. In step 100, a sending party inputs a message to be transmitted to a receiving subscriber. The message may be input into the communication system directly by the sending party through a mobile unit, a standard telephone, a computer terminal, or equivalent device, or the message may be input indirectly by calling an operator at a service center who inputs the message into the system. In step 102, the information bits comprising the short message are encoded by an encoder located at the transmitter with an error detection code, such as CRC. The encoded message constitutes one or more codewords, each containing codeword bits or symbols. It should be recognized that the transmitter may be the satellite, a base station, or a mobile unit. In step 104,

-15-

bit repetition can be employed, such that each of the codeword bits or symbols output by the encoding means are repeated N times to form a packet containing N bits. It will be apparent that, instead of repeating individual bits or symbols, groups of two or more bits or symbols, or the entire codeword or codewords could also be repeated.

5 Packets are then transmitted such that each slot within a TDMA frame includes one or more packets of repeated bits, error detection coding bits, and a sync burst to enable the receiver to estimate the channel quality. All bits comprising the encoded short message are transmitted in this fashion. If bit repetition and message repetition are employed, once the entire encoded message has been transmitted, the transmission

10 of the message (in the form of packets of N codeword bits) can be repeated M times to achieve the desired signal margin. It will be appreciated that, since the short message may be transmitted from a satellite, base station, or mobile station, encoding and transmitting functions are provided in each of these devices. It will also be appreciated that, in order to implement the technique of the present invention, means

15 are included in the transmitter to determine the number of bit repetitions N, message repetitions M, and power increase necessary to achieve the signal margin required for successful transmission of the message.

In step 108, the receiving device (i.e., the mobile unit, satellite, base station, or equivalent device) samples the received signal, including the repeated encoded

20 message bits, error detection bits, and channel quality estimation bits, and generates a metric sum of the form $\gamma_j = \sum_{i=1}^N |r_{ij} - \hat{C}_j S|^2$, where r_{ij} is the sampled received signal corresponding to the i th repetition of the information bit or symbol S in packet repeat j , and C_j is the corresponding estimate of channel quality. In step

110, a decoder contained in the receiving device decodes each encoded bit or symbol

25 in the TDMA slot from the metric sums, using soft combining or majority logic voting, or other suitable decoding methods. To implement soft combining, the decoder adds metric sums as $\gamma = \sum_{j=1}^M \gamma_j$ and makes a bit or symbol decision based on the sum. To implement majority logic voting, the decoder makes a preliminary bit

-16-

or symbol decision for each metric y_j and then a makes a final bit or symbol decision by comparing all of the preliminary decisions. Thus, if the decoder has made M preliminary decisions, the decoder will determine that the corresponding information bit is a 1 if more than half of the preliminary decisions were 1; otherwise, the decoder will determine that the corresponding information bit is a 0. The same logic is used to decode a bit that is a 0. To prevent an error which might result if exactly half of the preliminary decisions are 0 and exactly half of the preliminary decisions are 1, M is chosen to be an odd number. The decoded bits are combined coherently and the multiple transmissions of the message are combined coherently to generate a message signal having an increased margin.

In step 112, an error detector contained in the receiving apparatus detects errors based on the CRC error detection coding provided at the transmitting apparatus. If no errors are detected, the message is displayed on the receiving subscriber's mobile unit in step 114. If an error is detected, then the message is not displayed at the receiving apparatus, the user is notified of an erroneous message by a displayed error message or by an audio signal, and the receiver requests the transmitter to retransmit message or the erroneous parts of the message in accordance with a bidirectional radio protocol described in more detail below.

According to the present invention, repeated transmission of messages may be used in combination with repetition of individual portions of a message. That is, individual portions of the message may be transmitted multiple times, and when the entire message has been transmitted by means of the repeated transmissions of the message portions, the entire message may be transmitted again.

According to one embodiment, to implement a satellite-based mobile communication having a SMS feature according to the present invention, a message channel is formed by "stealing" or borrowing frames from the slow associated control channel SACCH. For example, the transmitter can assign every 8th frame of the SACCH channel for use as a message frame to carry SMS information; this

-17-

implementation would provide one SMS frame for each 104 regular TDMA frames, or one SMS frame approximately every 1.92 seconds. It will be appreciated that by using every eighth SACCH frame, the SACCH data rate is reduced by one-eighth, which does not adversely affect the system. In the SMS channel, an exemplary frame
5 format is shown in FIG. 5A, and includes two forward correction channel (FCH) slots, two idle slots, two synchronization channel (SCH) slots, two additional idle slots, and 24 data slots, for a total of 32 slots for each SMS frame. The 24 data slots are used to transmit message information. Each one of the 24 data slots is assigned to a corresponding mobile unit, such that each subscriber receives one data slot per
10 SMS frame. Thus, the data slot or slots in each message frame which are assigned to a particular subscriber's mobile unit constitute a message channel for that subscriber. It will be appreciated that alternate frame formats may be used, and that multiple data slots may be assigned to each mobile unit. Further, frames other than the SACCH frames may be used as message frames.

15 An encoder in the satellite suitably encodes message data. Bit and/or message repetition, in combination with increased transmission power, can also be implemented by the transmitter, as described above. Preferably, in this SMS implementation, each bit is transmitted three times, each message or portions thereof are transmitted three times, and the SMS frames are transmitted at approximately 6
20 dB more power than the voice frames and slots of the TDMA communication link. 104 frames, or approximately 1.92 seconds, are required for synchronization in this embodiment. Since one active SMS frame occurs for each 104 TDMA frames in this embodiment, the duty cycle is approximately 1%.

Because the short message service is implemented by using the relatively
25 infrequent stealing or borrowing of frames, it will be appreciated that the satellite or cellular system is not significantly affected in an adverse way.

According to another exemplary embodiment of the present invention, a high-penetration short message service can be implemented in a satellite-based

telecommunications system using the above-described transmission method as follows. On the carrier frequency that contains the broadcast control channel BCCH, the first slot of each (e.g., 16-slot) frame is allocated for the broadcast control channel. The broadcast control channel is implemented over 51 frames. The 51-
5 frame repeating pattern contains frequency and synchronization correction channels FCH and SCH, as well as broadcast and paging channels PCH. The carrier on which the satellite-mode BCCH is transmitted is not necessarily active in all timeslots. In particular, if no conversation is currently set up on the carrier of a given beam, only the BCCH slot of the carrier may contain energy; that is, the traffic and other slots
10 on the carrier will not contain energy.

Each BCCH slot is preferably transmitted at a higher power level than the mean power level of the traffic slots on the carrier. Preferably, the frequency correction channel FCH and the synchronization channel SCH of the BCCH are used for the short message service. In this embodiment, 4 slots in the 51-slot BCCH frame
15 are dedicated to the short message service. These SMS slots occur in frames 1, 13, 26 and 40. Thus, over the 51-slot BCCH frame, the SMS slots are spaced 12, 13, 14, 12, 12, 13, 14, ... slots apart, allowing the receiver to determine the frame timing solely by signal strength profile. The 4 SMS slots are transmitted at a higher power level than the remaining 47 BCCH slots, which are transmitted at a higher power
20 level than the remaining TDMA channel slots on the carrier containing the BCCH channel. It will be appreciated that this implementation of the broadcast control channel BCCH is unlike the standard GSM implementation in that the frequency correction channel FCH is not an unmodulated burst.

Referring now to FIG. 5B, the format of a burst transmitted on an SMS slot
25 according to an exemplary embodiment of the present invention is shown. The burst includes beam identification bits BEAM ID which identifies the satellite and the beam being used. If 14 bits are used for the BEAM ID, 16,384 unique identifiers are possible. This allows identification of, for example, up to 512 beams on each of 32

-19-

satellites may be identified. It will be appreciated that the identifiers may be reused on separate frequencies. The receiver can continuously average corresponding bits in each of multiple SMS bursts to effectively increase the signal margin of the BEAM ID information, allowing the BEAM ID to be determined even in non-ideal environments.

5 The SMS burst further includes two 64-bit datacodes DATACODE which form a 128-bit datacode. The 128-bit datacode can have one of between 1 and 128 mutually orthogonal values. These orthogonal values are bit patterns resembling synchronization words, and therefore provide the functions of frequency correction and synchronization to effectively replace the omitted channels FCH and SCH.

10 According to an exemplary embodiment, if 128 mutually orthogonal values are assumed, 7 bits of information are provided in each burst. In this embodiment, each message is repeated twice. Alternatively, a lower number of mutually orthogonal values may be assumed and the number of message transmissions can be reduced,

15 maintaining the same overall data throughput. Error correction coding may also be used, as will be described in more detail below.

A typical SMS message contains, for example, 112 bits. The 112 bits includes information bits and CRC error detection code bits. To transmit a 112-bit message twice, 224 message bits must be transmitted. As shown in FIG. 5B, each

20 SMS burst includes 156.25 bits which include 8.25 bits GUARD/RAMP for guard and ramp up/down functions, 6 tail bits TAIL, and 142 information bits. The 142 information bits include 14 BEAM ID bits and 128 datacode bits. Because the 128 datacode bits correspond to 7 information bits, 7 message bits are transmitted in each SMS burst. To deliver 224 message bits, 32 SMS bursts are required. Since there

25 are 4 SMS bursts for each 51-slot BCCH frame, 408 BCCH frames are required for each message. Based on a frame length of 9.23 mS, the 112-bit message is delivered in approximately 3.77 seconds. It will be appreciated that if the satellite system includes 121 beams, the satellite can deliver $(121/3.77)$ approximately 32 messages

-20-

per second.

The power required to implement an SMS system according to the above exemplary embodiments can be determined as follows. The BCCH channel as implemented above results in one BCCH burst every TDMA frame; thus, a BCCH
5 burst occurs once every 16th slot. The particular slot in which a given BCCH burst may occur is preferably staggered from satellite beam to satellite beam in a 16-cell pattern. Assuming the satellite has 121 beams, approximately 8 beams capable of transmitting SMS information are active at a given time, while the other 113 beams are transmitting traffic information. As previously described, the SMS slots are
10 spaced apart in slots 1, 13, 26, and 40 of a BCCH frame. This spacing allow for 12 orthogonal staggered SMS frames in different beams. Thus, the 8 beams simultaneously transmitting beams capable of carrying SMS information do not transmit SMS information at the same time. An SMS slot is transmitted in only one beam at a time, thereby maintaining a constant total phased array transmitter loading.

15 The link margin for the SMS signal is effectively increased by the combination of increased power, signal spreading from the 128-bit datacode, bit or message repetitions, and the gain due to the error correction coding. The link margin, excluding coding gain, for the above-described example can be determined as follows. The traffic channel provides a minimum 7 dB margin over an AWGN
20 channel. The SMS channel is transmitted using 9 dB additional power over the traffic channel, for an increased margin of 16 dB over an AWGN channel. The spreading gain due to the 128 chip code for 7 information bits provides an additional 12.6 dB gain, for an increased margin of 28.6 dB. Finally, message repetitions used in conjunction with soft decision decoding provides an additional 3 dB gain, for a total
25 SMS link margin of approximately 31.6 dB. Since error correction coding provides an additional gain, it will be appreciated that an SMS system according to the present invention provides a sufficient link margin to allow for communication even in non-ideal conditions, such as when the mobile unit is shadowed and/or the antenna is not

-21-

properly deployed.

As described above, the SMS system of the present invention allows synchronization to be achieved even though the SCH channel is used for SMS transmission. According to the present invention, synchronization can be achieved
5 as follows. The receiver locates the higher power SMS bursts using a power profile method based on average received signal strength. The receiver synchronizes itself with the incoming signal to the bit level by correlation with the orthogonal datacodes in each SMS burst. The correlations are added over the message repeats to provide an adequate signal-to-noise ratio to reliably decode message data. Once
10 synchronization is achieved, the mobile unit will sleep for 47 BCCH slots and wake up for the 4 SMS slots, resulting in a duty cycle of approximately 1/204. The mobile may also wake up an additional 4-8 slots over each 51-frame period, for example, to determine whether it can receive a normal calling channel. This additional receiver activity results in a duty cycle of approximately 1.5%.

15 It will be appreciated that the SMS system of the present invention may be implemented in other ways, and is not limited to the specific details of the exemplary embodiments described above. Thus, the SMS system of the present invention may be implemented using any particular slot or slots every N frames in a TDMA system. For example, a paging slot every fourth frame on a given carrier frequency in each
20 satellite beam can be used to selectively provide SMS service. When SMS service is not needed or desired, these slots can be used for voice traffic. In this embodiment, the SMS slot is transmitted using 6 dB more power than the voice slots on the same carrier. Successive SMS slots form a 13-slot SMS frame as shown in FIG. 6. The SMS frame in this embodiment has a first slot used for frequency
25 correction information and a second slot for synchronization information. Slots 3-13 are used for data or paging, and are of the format shown in FIG. 5B. Each data slot carries information bits for one receiver only. Each bit and each message in this embodiment can be transmitted three times. For a typical message consisting of 120

-22-

data bits, the time to deliver one message is approximately 11.5 seconds. Assuming a satellite having 150 beams, 13 messages can be delivered each second.

According to a further aspect of the present invention, the message repetitions are decorrelated by, for example, transmitting the message or message portions on
5 different frequencies, on different polarizations, or at appropriate time delays.

The transmission system of the present invention may further include forward error correction (FEC) means. In such an arrangement, the transmitter is provided with a second encoder for encoding the information bits of the short message with an error correction code, after encoding the information bits with an error detection
10 code. The message is transmitted, and the received message decoded, in the manner previously described. With majority logic voting, a hard decision decoder is employed, and the bits at the output of the majority logic voter are fed to a channel decoder with no additional information (such as bit reliability information estimated from the channel). If soft combining is used, a soft decision decoder is employed to
15 decode the error correction code, and metric sums y_j are added to the soft decision decoder output, and the sum is fed to an error correction decoder. Error correction coding will be more effective if different outputs of the error correction encoder are interleaved by separating consecutive output bits as far as possible in the transmission stream.

It will be appreciated that the higher the number of bit and message
20 repetitions, the better the performance of the system will be, but the longer the delay will be. A TDMA slot has a finite number of bits which may be used as either sync information or data. Increasing the number of bit repeats (N) in a packet necessarily requires a reduction in the number of sync bits. The metric sum depends upon the
25 estimated channel quality, and the channel quality depends upon the number of sync bits. If a TDMA slot has N_t bits, there are N_s sync bits/slot, and $N_t - N_s$ data bits per slot, then the gain in signal-to-noise ratio per bit due to repetition is approximately $(N_t N_s - N_s^2) / N_t$. The optimal gain in signal-to-noise ratio therefore occurs when

$N_s = N_t/2$. However, it will be appreciated that the choice of the number of sync bits and data bits in a given slot will depend upon the particular transmission scheme to be implemented.

As described above, the link established for communicating messages between a satellite and a mobile station is a bidirectional link. Accordingly, a radio protocol may be chosen for use between the satellite and the mobile station to enhance the utility of the short message system. For example, a simple protocol may be implemented in which a mobile station receiving a message would respond to the satellite with a "YES" or "NO" to indicate whether the message was received correctly. Alternatively, a more complicated protocol can be implemented in which a packet or group of packets is identified by a group ID and protected by CRC error detection code. If the CRC indicates that the message was not received correctly, then the satellite can resend the packets comprising the erroneous group. In this manner, only packets with errors need to be retransmitted, as opposed to resending a complete message. Thus, this protocol can be used to optimize the number of repeats and thereby minimize delay and wasted satellite power.

The bidirectional link of the SMS according to the present invention also provides for advantages with respect to billing. A unidirectional link prevents a short message delivery fee to be charged to the sender or recipient because there is no evidence that the message was correctly received. Thus, a SMS service with a unidirectional link may be offered to a subscriber at an increased subscription rate. In contrast, because a bidirectional link allows a message sender or service operator to determine whether a message was correctly received, the service operator can provide a SMS service with a delivery fee for each correctly received message only.

As discussed above, for longer messages, voice communications, or conditions requiring a link margin of greater than 30-40 dB, unacceptably long delays may result in the technique of the present invention. In such cases, the message may be stored at the satellite or corresponding cellular mobile switching center (MSC).

When the mobile unit is able to read the broadcast control channel (BCCH) of a more favorable communication channel, the unit may be alerted of the stored message by means of, for example, a flag on the broadcast control channel.

5 While the foregoing description includes numerous details and specificities, it is to be understood that these are merely illustrative of the features and principles of the present invention, and are not to be construed as limitations. Many modifications will be readily apparent to those of ordinary skill in the art which do not depart from the spirit and scope of the invention, as defined by the following claims and their legal equivalents.

WHAT IS CLAIMED IS:

1. A method for transmitting a short message service (SMS) data message over a TDMA communication channel having a plurality of frame sets, each frame set including a plurality of frames, wherein a subset of said plurality of frames are control channel frames for carrying control channel information at a first signal margin, the method comprising;
5
encoding said SMS data message to form an encoded data message; and
transmitting said encoded data message over a message channel at a second signal margin higher than the first signal margin, the message channel comprising one
10 or more of said control channel frames.
2. The method of claim 1, wherein said control channel frames include slow associated control channel (SACCH) frames.
3. The method of claim 2, wherein said message channel comprises one out of every eight SACCH frames.
- 15 4. The method of claim 1, wherein a portion of said second signal margin is obtained by transmitting the SMS data message at an increased transmit power.
5. The method of claim 1, wherein a portion of said second signal margin is obtained by coding the SMS data message using forward error correction coding.
6. The method of claim 1, wherein a portion of said second signal margin
20 is obtained by transmitting the SMS data message at an increased transmit power and by increased coding of the SMS data message.
7. The method of claim 1, wherein a portion of said second signal margin

is obtained by dividing the SMS data message into a plurality of packets of one or more bits, transmitting each packet a plurality of times, and integrating the transmissions of each packet at a mobile station.

5 8. The method of claim 1, wherein the SMS data message contains information alerting a mobile station to the presence of an incoming call.

 9. A method for transmitting a data message over a TDMA communication channel having a plurality of frames, each frame including a plurality of time slots, each time slot containing a plurality of data bits, wherein a predetermined one of said timeslots in each frame is a control channel timeslot, the
10 method comprising:

 encoding said data message to form one or more data codewords, each data codeword selected from a set of mutually orthogonal data codewords; and

 transmitting each data codeword over a message channel, the message channel comprising one or more of said control channel timeslots.

15 10. The method of claim 9, wherein the data codewords of said set of mutually orthogonal data codewords include frequency correction and synchronization information in addition to message data.

 11. The method of claim 10, wherein said one or more of said control channel timeslots is designated as a frequency correction channel (FCH) slot.

20 12. The method of claim 10, wherein said one or more of said control channel timeslots is designated as a synchronization channel (SCH) slot.

 13. The method of claim 10, wherein said control channel timeslots carry

control channel information at a first signal margin, and said message channel carries said data message at a second signal margin higher than said first signal margin.

14. The method of claim 13, wherein a portion of said second signal margin is obtained by transmitting said data message at an increased transmit power.

5 15. The method of claim 13, wherein a portion of said second signal margin is obtained by coding said data message using forward error correction coding.

10 16. The method of claim 13, wherein a portion of said second signal margin is obtained by transmitting said data message at an increased transmit power and by increased coding of said data message.

17. The method of claim 13, wherein a portion of said second signal margin is obtained by dividing said data message into a plurality of packets of one or more bits, transmitting each packet a plurality of times, and integrating the transmission of each packet at a mobile station.

15 18. The method of claim 13, wherein said data message contains information alerting a mobile station to the presence of an incoming call.

FIG. 1
PRIOR ART

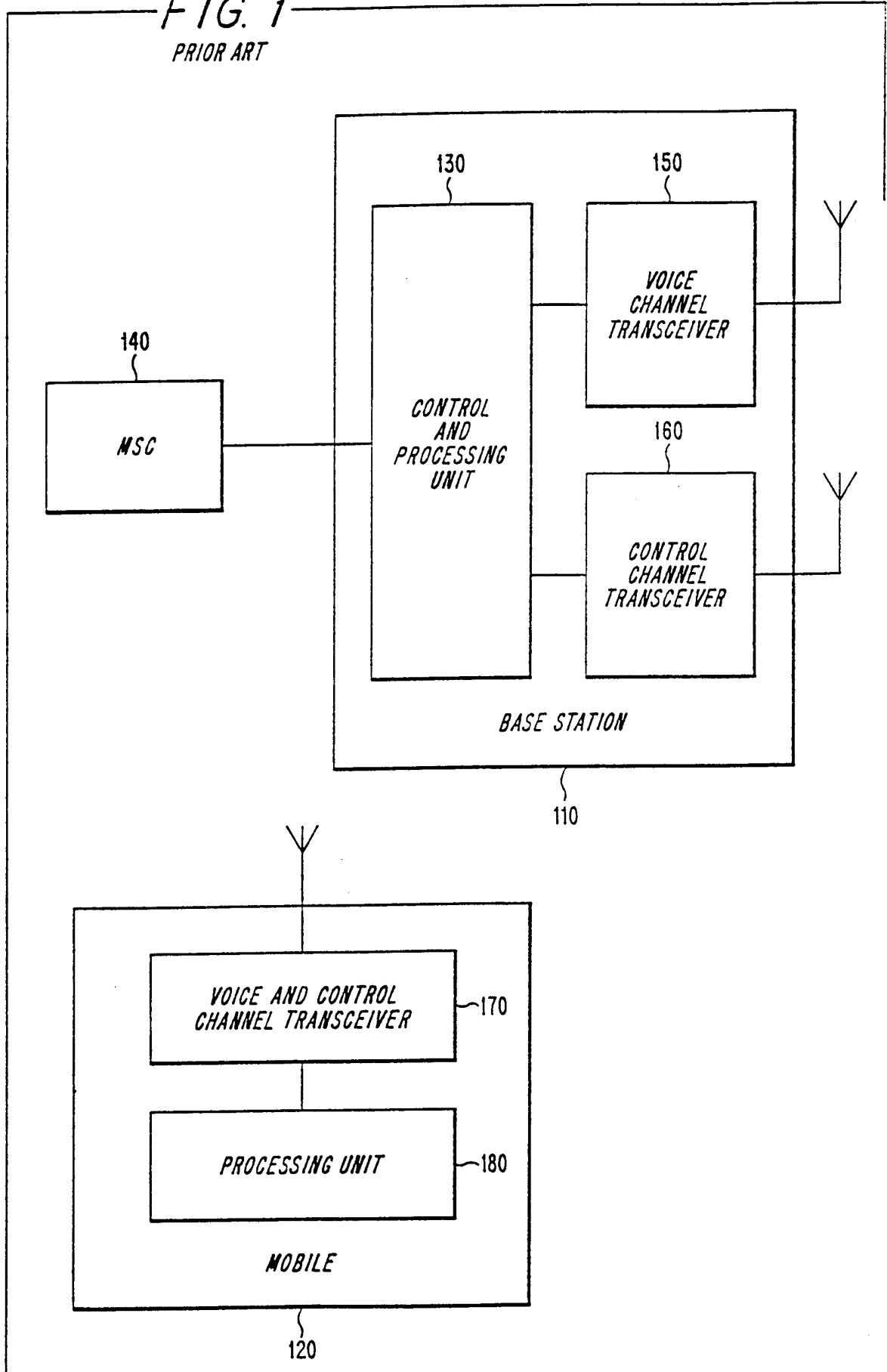
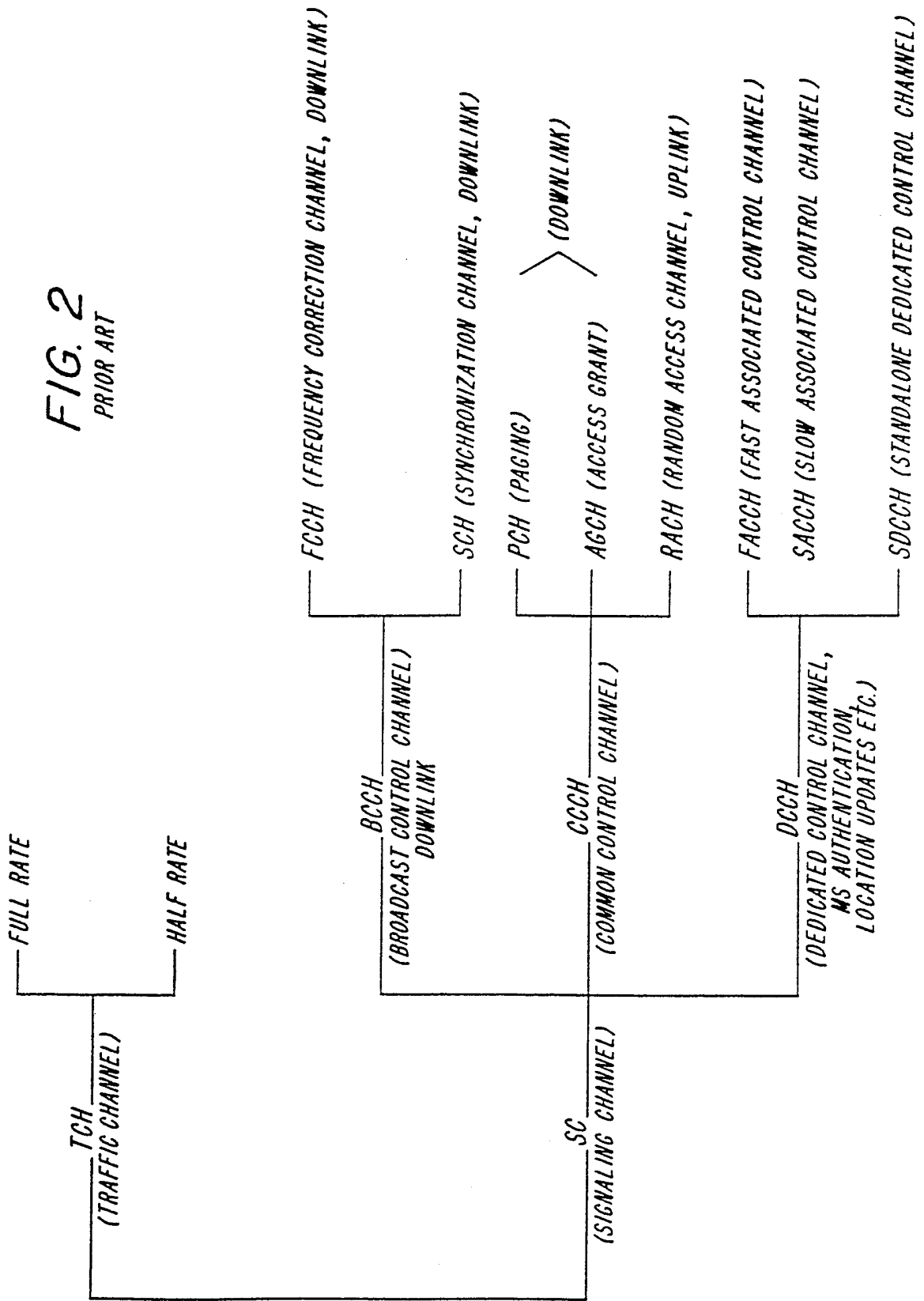

FIG. 2
PRIOR ART



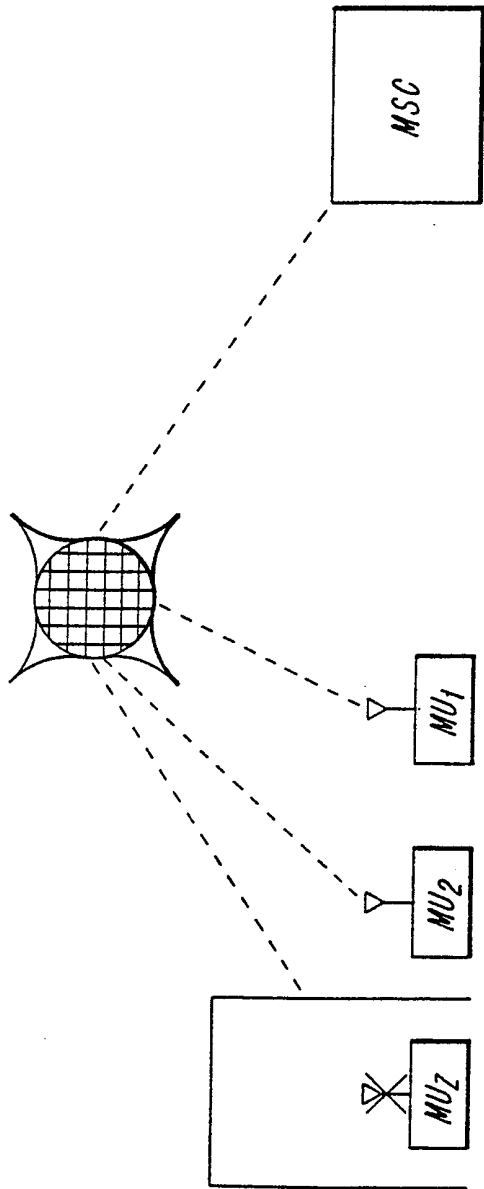

FIG. 3

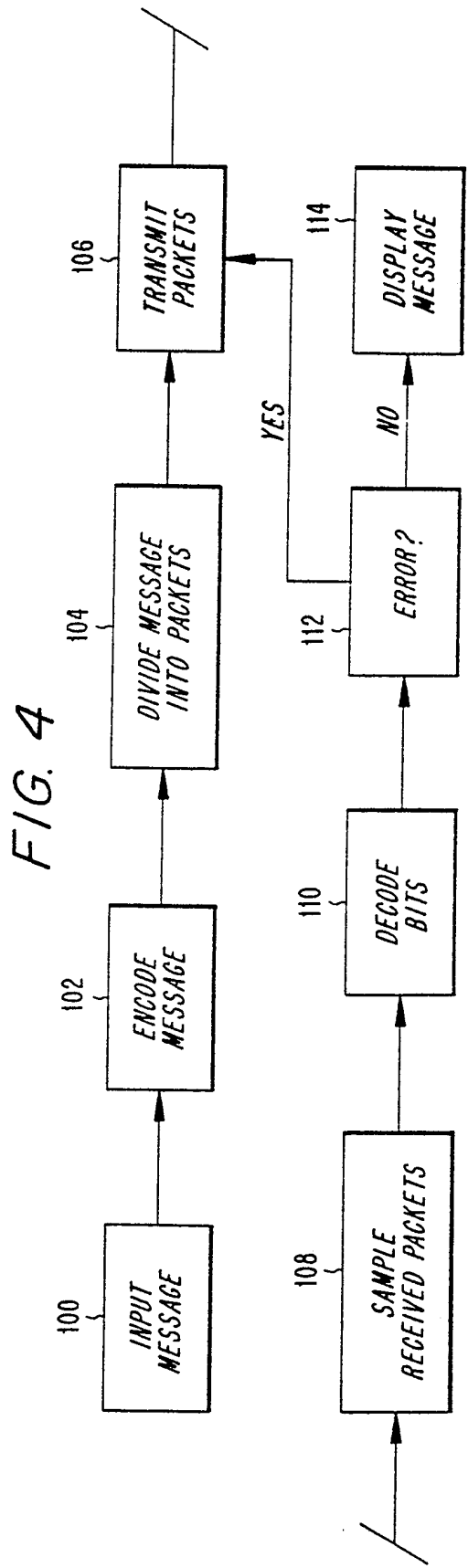

FIG. 4

FIG. 5b

GUARD/RAMP	TAIL	DATA CODE	BEAM ID	DATA CODE	TAIL	GUARD/RAMP
8.25 BITS	3 BITS	64 BITS	14 BITS	64 BITS	3 BITS	8.25 BITS

FIG. 6

FCH	SCH	DATA/PAGE	DATA/PAGE	DATA/PAGE	DATA/PAGE	DATA/PAGE	DATA/PAGE	DATA/PAGE	DATA/PAGE	DATA/PAGE	DATA/PAGE	DATA/PAGE
1	2	3	4	5	6	7	8	9	10	11	12	13