



US00D491848S1

(12) **United States Design Patent**
Metros et al.

(10) **Patent No.:** **US D491,848 S**

(45) **Date of Patent:** **** Jun. 22, 2004**

(54) **EXTERIOR OF VEHICLE FRONT BUMPER**

(75) Inventors: **Craig Metros**, Bloomfield, MI (US);
Patrick J. Schiavone, Birmingham, MI (US);
Tyler Jon Blake, Dearborn, MI (US)

(73) Assignee: **Ford Global Technologies, LLC**,
Dearborn, MI (US)

(**) Term: **14 Years**

(21) Appl. No.: **29/171,854**

(22) Filed: **Dec. 2, 2002**

(51) **LOC (7) Cl.** **12-16**

(52) **U.S. Cl.** **D12/169**

(58) **Field of Search** D12/169, 196,
D12/90-92; 293/102, 113, 115, 117, 120;
296/180.1, 180.2

(56) **References Cited**

U.S. PATENT DOCUMENTS

D447,453 S * 9/2001 Kim D12/169
D471,494 S * 3/2003 Chan D12/169
D473,168 S * 4/2003 Hayashi D12/169

OTHER PUBLICATIONS

Photographs of commercial parts—15 pages.
Photographs of Commercial Parts, 6 pages.
Photographs of commercial parts—40 pages.
Ford Motor Company; excerpts from product brochure
entitled “1978 Ford Pickups”.
Ford Motor Company; excerpts from product brochure
entitled “’78 Ford Pickups. Tough All Over”.
Ford Motor Company; excerpts from product brochure
entitled “Ford Truck Accessories and Specialties Catalog”;
published 1978.
Ford Motor Company; excerpts from product brochure
entitled “Nuovo Ford Transit”; published circa 1978.
Ford Motor Company; excerpts from product brochure
entitled “’78 Ford Courier”.

Ford Motor Company; excerpts from product brochure
entitled “Tough Ford pickups: America’s No. 1 seller.”;
published circa 1977.

Ford Motor Company; excerpts from product brochure
entitled “1978 Ford Recreation Vehicles”.

Ford Motor Company; excerpts from product brochure
entitled “1978 Ford 4-Wheelers”.

Ford Motor Company; excerpts from product brochure
entitled “1978 Ford Bronco”.

Ford Motor Company; excerpts from product brochure
entitled “1978 Ford Club Wagons”.

Ford Motor Company; excerpts from product brochure
entitled “Free Wheelin’ Ford Trucks”; published circa 1977.

Ford Motor Company; excerpts from product brochure
entitled “1978 Ford Econoline”.

Ford Motor Company; excerpts from product brochure
entitled “1978 Ford Courier”.

Ford Motor Company; excerpts from product brochure
entitled “1979 Ford Recreation Vehicles”.

Ford Motor Company; excerpts from product brochure
entitled “Ford Club Wagon Van”; published circa 1978.

(List continued on next page.)

Primary Examiner—Melody N. Brown

(74) *Attorney, Agent, or Firm*—David B. Kelley

(57) **CLAIM**

The ornamental design for a exterior of vehicle front
bumper, as shown and described.

DESCRIPTION

FIG. 1 is a perspective view of a vehicle bumper in accordance with an embodiment of the present invention; FIG. 2 is a front view of the vehicle bumper of FIG. 1; FIG. 3 is a top view of the vehicle bumper of FIG. 1; and, FIG. 4 is a front view of the vehicle bumper of FIG. 1. The bumper is intended for attachment to front of a vehicle, and the broken lines in the drawings are not part of the claimed design. The bottom and rear views of the bumper are not part of the claimed design. The side views of the vehicle bumper are mirror images of one another.

1 Claim, 2 Drawing Sheets

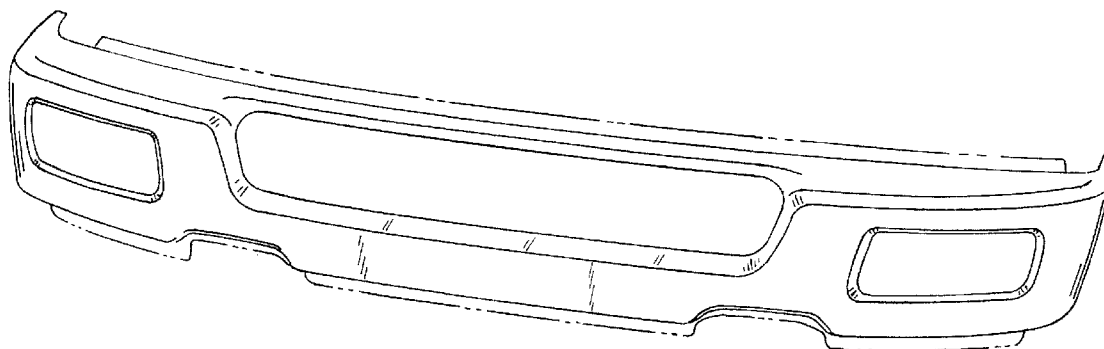

OTHER PUBLICATIONS

- Ford Motor Company; excerpts from product brochure entitled "1979 Ford 4-Wheelers".
- Ford Motor Company; excerpts from product brochure entitled "1979 Ford Club Wagons".
- Ford Motor Company; excerpts from product brochure entitled "'79 Free Wheelin' Ford Trucks".
- Ford Motor Company; excerpts from mail advertisement entitled "Ford Explorer Special Edition Sale"; published circa 1978.
- Ford Motor Company; excerpts from product brochure entitled "1979 Ford Courier".
- Ford Motor Company; excerpts from product brochure entitled "1979 Ford Econoline".
- Ford Motor Company; excerpts from product brochure entitled "Ford Truck Accessories"; published circa 1978.
- Ford Motor Company; excerpts from product brochure entitled "1979 Ford Bronco".
- Ford Motor Company; excerpts from product brochure entitled "1979 Ford Pickups".
- Ford Motor Company; excerpts from product brochure entitled "Ford 1980 Econoline Chassis".
- Ford Motor Company; excerpts from product brochure entitled "Pickup 4-Wheeler Bronco"; published circa 1979.
- Ford Motor Company; excerpts from product brochure entitled "1980 Bronco".
- Ford Motor Company; excerpts from product brochure entitled "Econoline/Club Wagon—1980 Confidential Preview".
- Ford Motor Company; excerpts from product brochure entitled "Ford 1980 Bronco".
- Ford Motor Company; excerpts from product brochure entitled "Ford 1980 Pickup".
- Ford Motor Company; excerpts from product brochure entitled "Ford 1980 Courier".
- Ford Motor Company; excerpts from product brochure entitled "1980 Free Wheelin' Fords".
- Ford Motor Company; excerpts from product brochure entitled "Ford 1980 4-Wheeler".
- Ford Motor Company; excerpts from product brochure entitled "Ford 1980 Econoline".
- Ford Motor Company; excerpts from product brochure entitled "The Captain's Club Wagon"; published circa 1979.
- Ford Motor Company; excerpts from product brochure entitled "Courier—1980 Confidential Preview".
- Ford Motor Company; excerpts from product brochure entitled "1980 Ford Courier".
- Ford Motor Company; excerpts from product brochure entitled "1980 F-Series".
- Ford Motor Company; excerpts from product brochure entitled "1980 Ford Bronco".
- Ford Motor Company; excerpts from product brochure entitled "1980 Ford Econoline".
- Ford Motor Company; excerpts from product brochure entitled "1980 Ford Bronco".
- Ford Motor Company; excerpts from product brochure entitled "Ford 1980 Club Wagon".
- Ford Motor Company; excerpts from product brochure entitled "Ford A-Serie"; published circa 1980.
- Ford Motor Company; excerpts from product brochure entitled "Pickups Ford"; published circa 1980.
- Ford Motor Company; excerpts from product brochure entitled "1981 Ford 4-Wheeler".
- Ford Motor Company; excerpts from product brochure entitled "1981 Ford Bronco".
- Ford Motor Company; excerpts from product brochure entitled "1981 Ford—The leadership lineup."
- Ford Motor Company; excerpts from product brochure entitled "1981 Ford Trucks".
- Ford Motor Company; excerpts from product brochure entitled "1981 Ford Club Wagon".
- Ford Motor Company; excerpts from product brochure entitled "1981 Ford Courier".
- Ford Motor Company; excerpts from product brochure entitled "1981 Ford Pickup".
- Ford Motor Company; excerpts from product brochure entitled "1981 Ford 4-Wheeler".
- Ford Motor Company; excerpts from product brochure entitled "1981 Ford Recreation Vehicles".
- Ford Motor Company; excerpts from product brochure entitled "1981 Ford Econoline Chassis".
- Ford Motor Company; excerpts from product brochure entitled "1981 Ford Econoline".
- Ford Motor Company; excerpts from product brochure entitled "1981 Ford Courier".
- Ford Motor Company; excerpts from product brochure entitled "Econoline/Club Wagon—1981 Confidential Preview".
- Ford Motor Company; excerpts from product brochure entitled "1981 Econoline Van/Club Wagon".
- Ford Motor Company; excerpts from product brochure entitled "1981 F-Series".
- Ford Motor Company; excerpts from product brochure entitled "1981 Bronco".
- Ford Motor Company; excerpts from product brochure entitled "F-Series—1981 Confidential Preview".
- Ford Motor Company; excerpts from product brochure entitled "Ford Truck Accessories and Specialties Catalog"; published circa 1982.
- Ford Motor Company; excerpts from product brochure entitled "'82 Ford Trucks".
- Ford Motor Company; excerpts from product brochure entitled "'82 Ford 4-Wheeler".
- Ford Motor Company; excerpts from product brochure entitled "'82 Ford Club Wagon".
- Ford Motor Company; excerpts from product brochure entitled "'82 Ford Econoline".
- Ford Motor Company; excerpts from product brochure entitled "'82 Ford Bronco".
- Ford Motor Company; excerpts from product brochure entitled "Ford 3000 1-Tonner"; published circa 1981.
- Ford Motor Company; excerpts from product brochure entitled "Ford 2400 Diesel 1-Tonner"; published circa 1981.
- Ford Motor Company; excerpts from product brochure entitled "'82 Ford F-Series Pickups".
- Ford Motor Company; excerpts from product brochure entitled "'82 Ford Econoline Chassis".
- Ford Motor Company; excerpts from product brochure entitled "1983 Ranger".
- Ford Motor Company; excerpts from product brochure entitled "America's Truck"; published circa 1982.
- Ford Motor Company; excerpts from product brochure entitled "1983 F-Series".
- Ford Motor Company; excerpts from product brochure entitled "1983 Bronco".
- Ford Motor Company; excerpts from product brochure entitled "1983 Econoline Van/Club Wagon".

Ford Motor Company; excerpts from product brochure entitled "'83 Ford Bronco".

Ford Motor Company; excerpts from product brochure entitled "'83 Ford Trucks".

Ford Motor Company; excerpts from product brochure entitled "'83 Ford 4-Wheelers".

Ford Motor Company; excerpts from product brochure entitled "1983 Ford Recreation Vehicles".

Ford Motor Company; excerpts from product brochure entitled "'83 Ford Chassis Cab".

Ford Motor Company; excerpts from product brochure entitled "'83 Ford Econoline".

Ford Motor Company; excerpts from product brochure entitled "Ford 1600 1-Tonner LWB"; published circa 1982.

Ford Motor Company; excerpts from product brochure entitled "Show Your Stripes—Create Bronco II Excitement"; published circa 1982.

Ford Motor Company; excerpts from product brochure entitled "'83 Ford F-Series Pickup".

Ford Motor Company; excerpts from product brochure entitled "'83 Ford Club Wagon".

Ford Motor Company; excerpts from product brochure entitled "'83 Ford Trucks".

Ford Motor Company; excerpts from product brochure entitled "'83 Ford Ranger".

Ford Motor Company; excerpts from product brochure entitled "Ford Bronco II—It's A Brand New Kick!!".

Ford Motor Company; excerpts from product brochure entitled "Accessories for Ford Light Trucks & Vans"; published circa 1983.

Ford Motor Company; excerpts from product brochure entitled "1984 Ford Wagons".

Ford Motor Company; excerpts from product brochure entitled "Aerostar Wars"; published circa 1983.

Ford Motor Company; excerpts from product brochure entitled "Concept Aerostar"; published circa 1983.

Ford Motor Company; excerpts from product brochure entitled "'84 Ford Trucks".

Ford Motor Company; excerpts from product brochure entitled "1984 Ford Econoline Van".

Ford Motor Company; excerpts from product brochure entitled "1984 Ford Club Wagon".

Ford Motor Company; excerpts from product brochure entitled "Introducing the all new trim-size 1984 Ford Bronco II".

Ford Motor Company; excerpts from product brochure entitled "1984 Ford Bronco II".

Ford Motor Company; excerpts from product brochure entitled "1984 Ford Ranger".

Ford Motor Company; excerpts from product brochure entitled "1984 Ford F-Series Pickup".

Ford Motor Company; excerpts from product brochure entitled "1984 Ford Bronco".

Ford Motor Company; excerpts from product brochure entitled "1984 Ford Chassis-Cab".

Ford Motor Company; excerpts from product brochure entitled "1984 Ford Trucks".

Ford Motor Company; excerpts from product brochure entitled "1984 Explorer Program".

Ford Motor Company; excerpts from product brochure entitled "1985 Ford Bronco II".

Ford Motor Company; excerpts from product brochure entitled "1985 Ford RV & Trailering Guide".

Ford Motor Company; excerpts from product brochure entitled "1985 Ford Trucks".

Ford Motor Company; excerpts from product brochure entitled "1985 Ford Econoline Van".

Ford Motor Company; excerpts from product brochure entitled "1985 Ford Club Wagon".

Ford Motor Company; excerpts from product brochure entitled "1985 Ford Bronco".

Ford Motor Company; excerpts from product brochure entitled "The Aussie Ute"; published circa 1984.

Ford Motor Company; excerpts from product brochure entitled "1985 Ford Chassis-Cab".

Ford Motor Company; excerpts from product brochure entitled "1985 F-Series Explorer Package 'A'".

Ford Motor Company; excerpts from product brochure entitled "1985 Ford Ranger".

Ford Motor Company; excerpts from product brochure entitled "Ford Bantam"; published circa 1984.

Ford Motor Company; excerpts from product brochure entitled "1985 Concept Aerostar".

Ford Motor Company; excerpts from product brochure entitled "Ford 1-Tonner"; published circa 1984.

Ford Motor Company; excerpts from product brochure entitled "Ford 1-Tonner 1600"; published circa 1984.

Ford Motor Company; excerpts from product brochure entitled "F-Series Pickup"; published circa 1984.

Ford Motor Company; excerpts from product brochure entitled "1985 Ford Wagons".

Ford Motor Company; excerpts from product brochure entitled "1986 Ford Aerostar Wagon".

Ford Motor Company; excerpts from product brochure entitled "Ford Aerostar Wagon"; published circa 1985.

Ford Motor Company; excerpts from product brochure entitled "Ford Club Wagon"; published circa 1985.

Ford Motor Company; excerpts from product brochure entitled "Ford Bronco".

Ford Motor Company; excerpts from product brochure entitled "Ford Econoline"; published circa 1985.

Ford Motor Company; excerpts from product brochure entitled "Der Transit"; published circa 1985.

Ford Motor Company; excerpts from product brochure entitled "Der Econovan"; published circa 1985.

Ford Motor Company; excerpts from product brochure entitled "1986 Ford Bronco".

Ford Motor Company; excerpts from product brochure entitled "Ford F-Series"; published circa 1985.

Ford Motor Company; excerpts from product brochure entitled "Ford Light Trucks & Vans Accessories '86".

Ford Motor Company; excerpts from product brochure entitled "Today's Crowd Pleasers—Spectron, Spectron Spacer, Spectron 4WD"; published circa 1985.

Ford Motor Company; excerpts from product brochure entitled "1986 Ford Trucks".

Ford Motor Company; excerpts from product brochure entitled "1986 Ford Econoline".

Ford Motor Company; excerpts from product brochure entitled "Transportation Concept for the 80's and Beyond".

Ford Motor Company; excerpts from product brochure entitled "1986 Ford F Series".

Ford Motor Company; excerpts from product brochure entitled "1986 Ford Bronco II".

Ford Motor Company; excerpts from product brochure entitled "1986 Ford Bronco".

Ford Motor Company; excerpts from product brochure entitled "1986 Ford Chassis-Cab".

Ford Motor Company; excerpts from product brochure entitled "1986 Ford Club Wagon".

Ford Motor Company; excerpts from product brochure entitled "1986 Aerostar".

Ford Motor Company; excerpts from product brochure entitled "1986 Aerostar Wagon".

Ford Motor Company; excerpts from product brochure entitled "1986 Ford Ranger".

Ford Motor Company; excerpts from product brochure entitled "1986 Ford Trucks".

Ford Motor Company; excerpts from product brochure entitled "1987 Advance Light Truck Facts Book".

Ford Motor Company; excerpts from product brochure entitled "1987 Ford Trucks".

Ford Motor Company; excerpts from product brochure entitled "New Ford Courier 4WD"; published circa 1986.

Ford Motor Company; excerpts from product brochure entitled "The Big Aussie Six"; published circa 1986.

Ford Motor Company; excerpts from product brochure entitled "1987 Ford Chassis-Cab".

Ford Motor Company; excerpts from product brochure entitled "1987 Ford Bronco".

Ford Motor Company; excerpts from product brochure entitled "1987 Ford Econoline".

Ford Motor Company; excerpts from product brochure entitled "1987 Ford Ranger".

Ford Motor Company; excerpts from product brochure entitled "1987 Ford Club Wagon".

Ford Motor Company; excerpts from product brochure entitled "1987 Ford Bronco II".

Ford Motor Company; excerpts from product brochure entitled "1987 Ford Aerostar Wagon".

Ford Motor Company; excerpts from product brochure entitled "1987 Ford Aerostar Van".

Ford Motor Company; excerpts from product brochure entitled "1987 Ford F-Series Pickup".

Ford Motor Company; excerpts from product brochure entitled "1988 Ford Wagons".

Ford Motor Company; excerpts from product brochure entitled "New Ford F-Series"; published circa 1987.

Ford Motor Company; excerpts from product brochure entitled "Maverick Wagon"; published circa 1987.

Ford Motor Company; excerpts from product brochure entitled "Maverick Cab Chassis/Pick-up"; published circa 1987.

Ford Motor Company; excerpts from product brochure entitled "1988 Ford Ranger".

Ford Motor Company; excerpts from product brochure entitled "1988 Ford Bronco II".

Ford Motor Company; excerpts from product brochure entitled "1988 Ford Bronco".

Ford Motor Company; excerpts from product brochure entitled "1988 Ford Club Wagon".

Ford Motor Company; excerpts from product brochure entitled "1988 Ford Econoline".

Ford Motor Company; excerpts from product brochure entitled "1988 Ford Chassis-Cab".

Ford Motor Company; excerpts from product brochure entitled "Ford Taurus Wagon, Ford Bronco 4x4"; published circa 1987.

Ford Motor Company; excerpts from product brochure entitled "1988 Ford Aerostar Van".

Ford Motor Company; excerpts from product brochure entitled "1988 Ford Aerostar Wagon".

Ford Motor Company; excerpts from product brochure entitled "1988 Ford F-Series Pickup".

Ford Motor Company; excerpts from product brochure entitled "Ranger"; published circa 1987.

Ford Motor Company; excerpts from product brochure entitled "1988 Ford Trucks".

Unknown Author; excerpts from product brochure entitled "Auto Focus"; illustrating 1988 Ford F-series truck.

Jan A. Zverina of United Press International.; excerpts from newspaper illustrating 1989 Ford Bronco II.

Ford Motor Company; excerpts from magazine advertisement illustrating 1988 Ford Ranger entitled "Ranger Pickup Bed Cap".

Ford Motor Company; excerpts from product brochure entitled "Ford Pre-Runner Ranger Packages—Accent Accessories 88".

Ford Motor Company; excerpts from product brochure entitled "Electrically Powered F-Series Rear Window For Pickups"; published circa 1988.

Ford Motor Company; excerpts from product brochure entitled "1984 F-Series LPO"; published circa 1988.

Ford Motor Company; excerpts from product brochure entitled "1989 Ford Trucks".

Ford Motor Company; excerpts from product brochure entitled "Ford Light Trucks Accessories 89".

Ford Motor Company; excerpts from product brochure entitled "1989 Ford Bronco II".

Ford Motor Company; excerpts from product brochure entitled "1989 Ford Econoline/Club Wagon".

Ford Motor Company; excerpts from product brochure entitled "1989 Ford Ranger".

Ford Motor Company; excerpts from product brochure entitled "1989 Ford Aerostar".

Ford Motor Company; excerpts from product brochure entitled "Commericals Oct. 1989".

Ford Motor Company; excerpts from product brochure entitled "1989 Ford Club Wagon".

Ford Motor Company; excerpts from product brochure entitled "1989 Ford F-Series".

Ford Motor Company; excerpts from product brochure entitled "1989 Ford Ranger".

Ford Motor Company; excerpts from product brochure entitled "1989 Ford Bronco".

Ford Motor Company; excerpts from product brochure entitled "1989 Ford Aerostar Wagon".

Ford Motor Company; excerpts from product brochure entitled "1990 F-Series Major Product Changes".

Ford Motor Company; excerpts from product brochure entitled "1990 Econoline/Club Wagon Major Product Changes".

Ford Motor Company; excerpts from product brochure entitled "1990 Aerostar Wagon and Van Major Product Changes".

Ford Motor Company; excerpts from product brochure entitled "1990 Ford Recreation Vehicle and Trailer Towing Guide".

Ford Motor Company; excerpts from product brochure entitled "Aerostar 4-Wheel Drive"; published circa 1989.

Ford Motor Company; excerpts from product brochure entitled "Ford Trucks"; published circa 1989.

Ford Motor Company; excerpts from product brochure entitled "1984 Ford Club Wagon"; published circa 1989.

- Ford Motor Company; excerpts from product brochure entitled "Ford Aerostar Wagon"; published circa 1989.
- Ford Motor Company; excerpts from product brochure entitled "Ford Bronco II"; published circa 1989.
- Ford Motor Company; excerpts from product brochure entitled "1990 Ford F-Series".
- Ford Motor Company; excerpts from product brochure entitled "1990 Ford Econoline and Aerostar Vans".
- Ford Motor Company; excerpts from product brochure entitled "1990 Ford Bronco".
- Ford Motor Company; excerpts from product brochure entitled "1990 Ford Ranger".
- Ford Motor Company; excerpts from product brochure entitled "1990 Ford Chassis-Cab".
- Ford Motor Company; excerpts from product brochure entitled "1990 Ranger Major Product Changes".
- Ford Motor Company; excerpts from product brochure entitled "1990 Bronco Major Product Changes".
- Ford Motor Company; excerpts from product brochure entitled "1990 Bronco II Major Product Changes".
- Ford Motor Company; excerpts from product brochure entitled "1991 Aerostar Major Product Changes".
- Ford Motor Company; excerpts from product brochure entitled "1991 Ford Ranger".
- Ford Motor Company; excerpts from product brochure entitled "1991 Econoline/Club Wagon Major Product Changes".
- Ford Motor Company; excerpts from product brochure entitled "1991 Ranger Major Product Changes".
- Ford Motor Company; excerpts from product brochure entitled "New 1991 Ford Explorer . . .".
- Ford Motor Company; excerpts from product brochure entitled "1991 Ford Explorer".
- Ford Motor Company; excerpts from product brochure entitled "1991 Ford Trucks".
- David Sedgwick; excerpts from Detroit News article entitled "Explorer puts ford sport utility in driver's seat"; published circa 1991.
- Al Haas of Knight-Ridder Newspapers; excerpts from newspaper article entitled "Sport-utility vehicles brighten dark sales year"; published circa 1991.
- Ford Motor Company; excerpts from product brochure entitled "1991 Ford F-Series".
- Ford Motor Company; excerpts from product brochure entitled "Commercials—1992 Edition Two".
- James V. Higgins; excerpts from Detroit News article entitled "Ford's new Flareside pickups near-perfect F-series addition"; published circa 1992.
- Paul Lienert; excerpts from newspaper article entitled "Club Wagon sets the standard"; published circa 1992.
- Paul Eisenstein; excerpts from Detroit News article entitled "Ford to boost production on hot Explorers"; published circa 1992.
- Ford Motor Company; excerpts from product brochure entitled "1992 Ford Trucks".
- Ford Motor Company; excerpts from product brochure entitled "1992 Ford Club Wagon".
- Ford Motor Company; excerpts from product brochure entitled "Ford Commercial Trucks 1992 Vans".
- Ford Motor Company; excerpts from product brochure entitled "Ford 1992, Aerostar Wagon".
- Ford Motor Company; excerpts from product brochure entitled "Ford 1992, Bronco".
- Ford Motor Company; excerpts from product brochure entitled "1992 Ford F-Series, Flareside".
- Ford Motor Company; excerpts from product brochure entitled "Ford 1992, Explorer".
- Ford Motor Company; excerpts from product brochure entitled "Ford Trucks 1992, Ranger".
- Ford Motor Company; excerpts from product brochure entitled "Ford 1992, F-Series".
- Ford Motor Company; excerpts from product brochure entitled "Ford '93 F-Series".
- Ford Motor Company; excerpts from product brochure entitled "'93 Ford Trucks".
- Ford Motor Company; excerpts from product brochure entitled "1993 Ranger".
- Ford Motor Company; excerpts from product brochure entitled "Ford '93 Ranger".
- Ford Motor Company; excerpts from product brochure entitled "Ford Commercial Trucks '93, Pickups & Chassis".
- Ford Motor Company; excerpts from product brochure entitled "Ford '93 Bronco".
- Ford Motor Company; excerpts from product brochure entitled "1993 Bronco".
- Ford Motor Company; excerpts from product brochure entitled "1993 F-Series".
- Ford Motor Company; excerpts from product brochure entitled "1993 Econoline/Club Wagon".
- Ford Motor Company; excerpts from product brochure entitled "1993 Aerostar".
- Ford Motor Company; excerpts from product brochure entitled "Utility Light Trucks & Vans Accessories"; published circa 1992.
- Ford Motor Company; excerpts from product brochure entitled "Ford '93, Explorer".
- Ford Motor Company; excerpts from product brochure entitled "Roll Along, Crew Cab DRW"; published circa 1992.
- Ford Motor Company; excerpts from product brochure entitled "Roll Along, Super Cab SRW"; published circa 1992.
- Ford Motor Company; excerpts from product brochure entitled "Roll Along, Crew Cab 4x4"; published circa 1992.
- Ford Motor Company; excerpts from product brochure entitled "Roll Along, Super Cab DRW"; published circa 1992.
- Ford Motor Company; excerpts from product brochure entitled "Roll Along, Bronco"; published circa 1992.
- Ford Motor Company; excerpts from product brochure entitled "Roll Along, Super Cab 4x4"; published circa 1992.
- James V. Higgins; excerpts from Detroit News article entitled "1993 Ranger redesign makes a first-class pickup better"; published Jan. 20, 1993.
- Russ Devault of Atlanta Journal Constitution; excerpts from Detroit Free Press article entitled "Sporty components give the Lightning flexibility"; published Mar. 4, 1993.
- Unknown Author; excerpts from newspaper article illustrating a Ford Ranger XLT SuperCab 4x4; article entitled "Ford Ranger is unchallenged . . ."; published Feb. 25, 1993.
- James V. Higgins; excerpts from Detroit News article entitled "It's thumbs up for Lightning, but down for Mustang Cobra"; published May 12, 1993.
- Ford Motor Company; excerpts from product brochure entitled "F-Series"; published circa 1989.
- Ford Motor Company; excerpts from product brochure entitled "1990 Ford Bronco II".

- Ford Motor Company; excerpts from product brochure entitled "Ford 1992 Bronco".
- Ford Motor Company; excerpts from product brochure entitled "Ford Trucks 1992 Ranger".
- Ford Motor Company; excerpts from product brochure entitled "Ford 1992 Explorer".
- Ford Motor Company; excerpts from product brochure entitled "1992 Ford F-Series Flareside".
- Ford Motor Company; excerpts from product brochure entitled "Ford 1992 F-Series".
- Ford Motor Company; excerpts from product brochure entitled "Ford '93 F-Series".
- Ford Motor Company; excerpts from product brochure entitled "Ford 1994 F-Series".
- Ford Motor Company; excerpts from product brochure entitled "Ford 1994 Pickups & Chassis".
- Ford Motor Company; excerpts from product brochure entitled "Ford 1994 Explorer".
- Ford Motor Company; excerpts from product brochure entitled "Ford 1994 Ranger".
- Ford Motor Company; excerpts from product brochure entitled "1994 Ford F-150 Lightning".
- Ford Motor Company; excerpts from product brochure entitled "F-Series Pickup"; published circa 1993.
- Ford Motor Company; excerpts from product brochure entitled "1995 Ford Ranger".
- Ford Motor Company; excerpts from product brochure entitled "1995 Ford Bronco".
- Ford Motor Company; excerpts from product brochure entitled "1995 Ford Explorer".
- Ford Motor Company; excerpts from product brochure entitled "1996 Ford F-Series".
- Ford Motor Company; excerpts from product brochure entitled "1997 F-Series".
- Ford Motor Company; excerpts from product brochure entitled "The All-New 1997 Ford F-150".
- Ford Motor Company; excerpts from product brochure entitled "1997 F-150 Accessories".
- Ford Motor Company; excerpts from product brochure entitled "1997 Ranger".
- Ford Motor Company; excerpts from product brochure entitled "The Nineteen Hundred and Ninety Eight Ranger".
- Ford Motor Company; excerpts from product brochure entitled "The Nineteen Hundred and Ninety Eight Explorer".
- Ford Motor Company; excerpts from product brochure entitled "The Nineteen Hundred and Ninety Eight Expedition".
- Ford Motor Company; excerpts from product brochure entitled "Expedition Ninety Nine".
- Ford Motor Company; excerpts from product brochure entitled "Ranger Ninety Nine".
- Ford Motor Company; excerpts from product brochure entitled "Explorer Ninety Nine".
- Ford Motor Company; excerpts from product brochure entitled "F-Series Ninety Nine".
- Ford Motor Company; excerpts from product brochure entitled "Harley-Davidson F-150"; published circa 1998.
- Ford Motor Company; excerpts from product brochure entitled "Customized Ford F-150 SuperCrew"; published circa 1998.
- Ford Motor Company; excerpts from product brochure entitled "2001 Escape".
- Ford Motor Company; excerpts from product brochure entitled "Excursion"; published circa 1999.
- Tony Swan; excerpts from newspaper illustrating 2000 Ford Excursion; published Aug. 5, 1999.
- Anita and Paul Lienert; excerpts from newspaper illustrating 2000 Ford Excursion.
- Ford Motor Company; excerpts from product brochure entitled "Expedition"; published circa 1999.
- Ford Motor Company; excerpts from product brochure entitled "2000 Ford Expedition XLT, XLT with Premium Sport Appearance Group, Eddie Bauer".
- Ford Motor Company; excerpts from product brochure entitled "Explorer 4 Door"; published circa 1999.
- Ford Motor Company; excerpts from product brochure entitled "Explorer Sport"; published circa 1999.
- Ford Motor Company; excerpts from product brochure entitled "2000-01 Explorer Sport".
- Ford Motor Company; excerpts from product brochure entitled "Ford, 2000 (Explorer), Sport".
- Ford Motor Company; excerpts from product brochure entitled "Ford, 2000 (Explorer), XLS, XLS Sport, XLT, XLT Sport, Eddie Bauer, Limited".
- Ford Motor Company; excerpts from product brochure entitled "2001 Explorer Sport Trac".
- Ford Motor Company; excerpts from product brochure entitled "Ranger"; published circa 1999.
- Ford Motor Company; excerpts from product brochure entitled "2001 Supercrew".
- Ford Motor Company; excerpts from product brochure entitled "Super Duty F-Series"; published circa 1999.
- Ford Motor Company; excerpts from product brochure entitled "F-Series, 1000 F-150 Series"; published circa 1999.
- Ford Motor Company; excerpts from product brochure entitled "Super Duty, 200 F-250/350 F-Series Pickups"; published circa 1999.
- Ford Motor Company; excerpts from product brochure entitled "Windstar"; published circa 1999.
- Ford Motor Company; excerpts from product brochure entitled "Food, 2000 Windstar".
- Ford Motor Company; excerpts from product brochure entitled "Ford, 2000 (Commercial Vehicles)".
- Ford Motor Company; excerpts from product brochure entitled "The Great Escape"; published circa 2000.
- Ford Motor Company; excerpts from product brochure entitled "2001 FordSVT F-150 Lightning".
- Ford Motor Company; excerpts from product brochure entitled "Over The Edge Ranger"; published circa 2000.
- Ford Motor Company; excerpts from product brochure entitled "Excursion Sightseer"; published circa 2000.
- Ford Motor Company; excerpts from product brochure entitled "Out Here, There Are No Boundaries"; published circa 2001.
- Toyota Motor Corporation; excerpts from product brochure entitled "Toyota 1996 4Runner".
- Toyota Motor Corporation; excerpts from product brochure entitled "Toyota 1997 T100".
- Toyota Motor Corporation; excerpts from product brochure entitled "Toyota Tacoma".
- Mark Williams; excerpts from Four Wheeler magazine article entitled "Three pickups battle terrain—and each other—for the golden prize"; published circa 1997.
- Toyota Motor Corporation; excerpts from product brochure entitled "Toyota Tundra"; published circa 1998.

- Toyota Motor Corporation; excerpts from product brochure entitled "1998 Toyota RAV4".
- Toyota Motor Corporation; excerpts from product brochure entitled "1999 4Runner".
- Toyota Motor Corporation; excerpts from product brochure entitled "1999 Land Cruiser".
- Toyota Motor Corporation; excerpts from product brochure entitled "2002 Tacoma".
- General Motors Corporation; excerpts from product brochure entitled "2000 Shopper's Guide".
- General Motors Corporation; excerpts from product brochure entitled "Professional Grade Sierra"; published circa 1999.
- General Motors Corporation; excerpts from product brochure entitled "GMC Product Guide"; published circa 1999.
- General Motors Corporation; excerpts from product brochure entitled "Introducing The Sierra Sport Special Edition"; published circa 2000.
- General Motors Corporation; excerpts from product brochure entitled "Safari, Quick Facts"; published circa 2000.
- General Motors Corporation; excerpts from product brochure entitled "Jimmy, Quick Facts"; published circa 2000.
- General Motors Corporation; excerpts from product brochure entitled "Yukon Denali, Quick Facts"; published circa 2000.
- General Motors Corporation; excerpts from product brochure entitled "Sonoma, Quick Facts"; published circa 2000.
- General Motors Corporation; excerpts from product brochure entitled "Yukon, Quick Facts"; published circa 2000.
- General Motors Corporation; excerpts from product brochure entitled "Sierra Heavy Duty, Quick Facts"; published circa 2000.
- General Motors Corporation; excerpts from product brochure entitled "Sierra Light Duty, Quick Facts"; published circa 2000.
- General Motors Corporation; excerpts from product brochure entitled "2002 Envoy".
- General Motors Corporation; excerpts from product brochure entitled "2002 Yukon/Yukon Denali".
- General Motors Corporation; excerpts from product brochure entitled "2002 Sierra".
- The Dodge Corporation; excerpts from product brochure entitled "Sport Utility Defined."; published circa 1997.
- The Dodge Corporation; excerpts from product brochure entitled "More power. More torque. More towing. More payload. More room."; published circa 1997.
- The Dodge Corporation; excerpts from product brochure entitled "1998 Dakota, The New Dodge".
- The Dodge Corporation; excerpts from product brochure entitled "1998 Ram Pickup, The New Dodge".
- The Dodge Corporation; excerpts from product brochure entitled "Different to the Maxx"; published circa 1999.
- The Dodge Corporation; excerpts from product brochure entitled "1998 Durango, The New Dodge".
- The Dodge Corporation; excerpts from product brochure entitled "2001 Durango".
- The Dodge Corporation; excerpts from product brochure entitled "2001 Ram".
- The Dodge Corporation; excerpts from product brochure entitled "Ram 1500 2002".
- The Dodge Corporation; excerpts from product brochure entitled "Ram 2500/3500 2002".
- Chevrolet; excerpts from product brochure entitled "Suburban"; published circa 2001.
- Chevrolet; excerpts from product brochure entitled "2002".
- Chevrolet; excerpts from product brochure entitled "Blazer"; published circa 2001.
- Chevrolet; excerpts from product brochure entitled "Tahoe"; published circa 2001.
- Chevrolet; excerpts from product brochure entitled "Silverado"; published circa 2001.
- Chevrolet; excerpts from product brochure entitled "Commercial Vehicles"; published circa 2001.
- Chevrolet; excerpts from product brochure entitled "S10"; published circa 2001.
- Chevrolet; excerpts from product brochure entitled "Commercial Trucks"; published circa 2001.
- Chevrolet; excerpts from product brochure entitled "Tracker"; published circa 2001.
- Chevrolet; excerpts from product brochure entitled "Trail Blazer EXT"; published circa 2001.
- Chevrolet; excerpts from product brochure entitled "Trail Blazer"; published circa 2001.
- Chevrolet; excerpts from product brochure entitled "Avalanche"; published circa 2001.
- Chevrolet; excerpts from product brochure entitled "2004 Colorado".
- Chevrolet; excerpts from product brochure entitled "2005 Equinox".
- Mazda Motor Corporation; excerpts from product brochure entitled "IN H 4x2"; published circa 1998.
- Anita and Paul Lienert; excerpts from newspaper article entitled "Two extra doors increase utility of Mazda B series"; published Oct. 7, 1998.
- Mazda Motor Corporation; excerpts from product brochure entitled "B-Series Trucks"; published circa 1998.
- Mazda Motor Corporation; excerpts from product brochure entitled "Mazda B-Series Truck"; published circa 1997.
- Dan Lienert; excerpts from Newspaper article entitled "All-new Mazda truck on outside houses pure Ranger on the inside"; published Aug. 6, 1997.
- Mazda Motor Corporation; excerpts from product brochure entitled "1998 Mazda B4000 4x4 SE Cab Plus".
- Mazda Motor Corporation; excerpts from product brochure entitled "1998 The B-Series Trucks by Mazda"; published circa 1997.
- Rachel Konrad of Free Press Automotive Writer; excerpts from Detroit Free Press article entitled "Nissan steers new vehicles toward turn-around"; published Dec. 31, 1998.
- Tony Swan; excerpts from newspaper article entitled "Frontier Crew Cab shows that Nissan still has good ideas"; published Apr. 29, 1999.
- Paul Lienert; excerpts from Detroit News article entitled "Nissan peers into the future"; published Aug. 5, 1998.
- Nissan Motor Company; excerpts from product brochure entitled "1999 Nissan Frontier".
- Nissan Motor Company; excerpts from product brochure entitled "Nissan Cars & Trucks 1998".
- Nissan Motor Company; excerpts from product brochure entitled "Nissan Frontier 1998".
- Nissan Motor Company; excerpts from product brochure entitled "2000 Frontier".

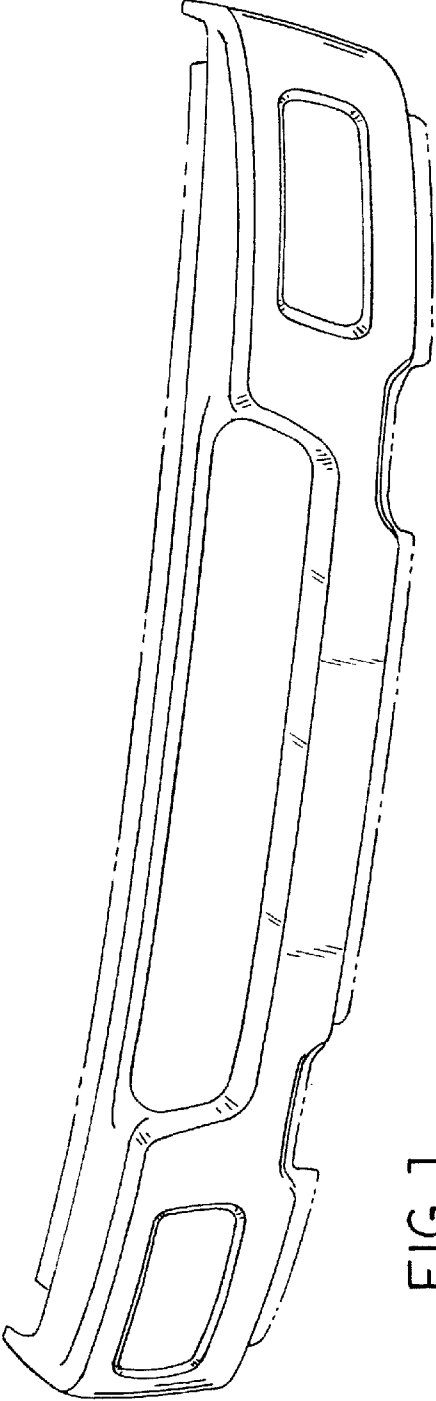

FIG. 1

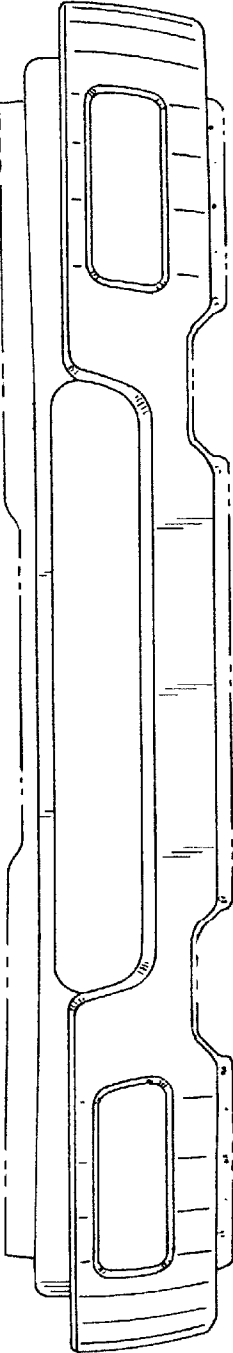

FIG. 2

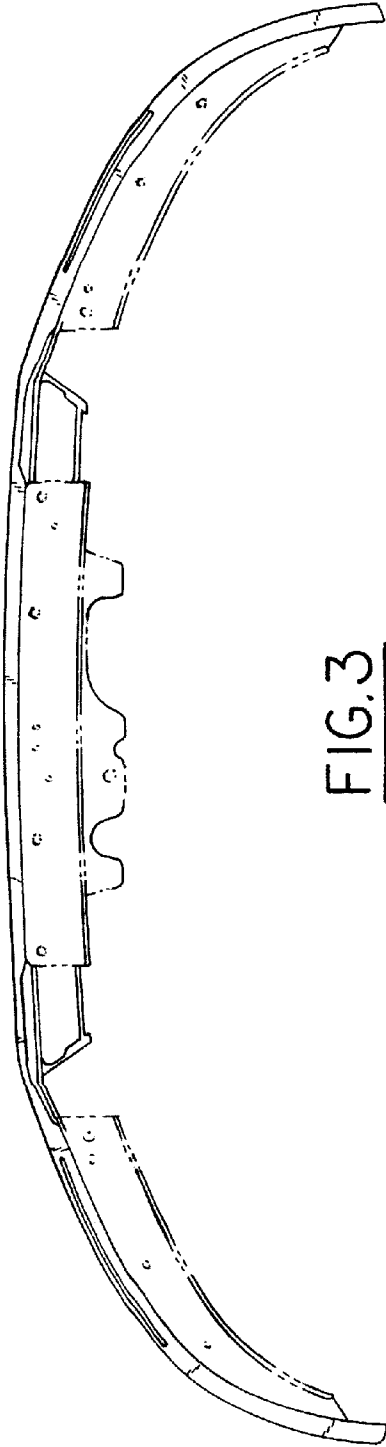

FIG. 3

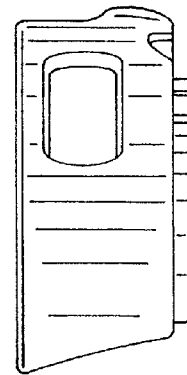

FIG. 4