

(12) PATENT
(19) AUSTRALIAN PATENT OFFICE

(11) Application No. AU 199640898 B2
(10) Patent No. 702538

(54) Title
A sensor for use in a tracking system employing global positioning system satellites

(51)⁶ International Patent Classification(s)
G01S 005/10

(21) Application No: 199640898 (22) Application Date: 1996 .01 .10

(30) Priority Data

(31) Number	(32) Date	(33) Country
697754	1991 .05 .09	US

(43) Publication Date : 1996 .04 .04
(43) Publication Journal Date : 1996 .04 .04
(44) Accepted Journal Date : 1999 .02 .25

(62) Divisional of:
199214997

(71) Applicant(s)
Navsys Corporation

(72) Inventor(s)
Alison K. Brown; Mark A. Sturza

(74) Agent/Attorney
BALDWIN SHELSTON WATERS,Level 21,60 Margaret Street,SYDNEY NSW 2000

(56) Related Art
US 4622557



AU9640898

(12) PATENT ABSTRACT (11) Document No. AU-A-40898/96
(19) AUSTRALIAN PATENT OFFICE

(54) Title
A SENSOR FOR USE IN A TRACKING SYSTEM EMPLOYING GLOBAL POSITIONING SYSTEM SATELLITES

International Patent Classification(s)
(51)⁶ **G01S 005/10**

(21) Application No. : **40898/96** (22) Application Date : **10.01.96**

(30) Priority Data

(31) Number (32) Date (33) Country
697754 09.05.91 US UNITED STATES OF AMERICA

(43) Publication Date : **04.04.96**

(62) Related to Division(s) : **14997/92**

(71) Applicant(s)
NAVSYS CORPORATION

(72) Inventor(s)
ALISON K. BROWN; MARK A. STURZA

(74) Attorney or Agent
SHELSTON WATERS , Level 21, 60 Margaret Street, SYDNEY NSW 2000

(57) Claim

1. A sensor mounted on each of a multiplicity of objects to be tracked in a tracking system employing global positioning system (GPS) satellites, the sensor comprising:

antenna means for receiving signals from one or more GPS satellites;

RF/IF means for receiving signals from said antenna means and for converting those signals to digital samples;

digital signal processing (DSP) means coupled to said RF/IF means for converting those digital samples to processed digital signals;

a crystal oscillator coupled to said RF/IF means and to said DSP means for generating a local oscillator signal and providing that local oscillator signal to said RF/IF means and to said DSP means; and

microcomputer means coupled to said DSP means for computing, from said signals received from one or more GPS satellites, sensor data comprising selected raw satellite measurements.

ABSTRACT

A tracking system employing global positioning system (GPS) satellites provides extremely accurate position, velocity, and time information for vehicles or any other animate or inanimate object within any mobile radio communication system or information system, including those operating in high rise urban areas. The tracking system includes a sensor (20) mounted on each object, a communication link (30), a workstation (40), and a GPS reference receiver (60). The sensor (20) operates autonomously following initialization by an external network management facility to sequence through the visible GPS satellites, making pseudo range and delta range or time difference and frequency difference measurements. No navigation functions are performed by the sensor (20), thereby permitting significant reductions in the cost thereof. The raw satellite measurements, with relevant timing and status information, are provided to the communication link (30) to be relayed periodically back to the workstation (40). Differential corrections may also be provided at the workstation (40) to increase the accuracy of the object location determination. In normal operation, three satellite measurements are required to compute the location of the object, but for a short time period a minimum of two satellite measurements are acceptable with time, altitude, and map aiding information being provided by the workstation (40).

AUSTRALIA

PATENTS ACT 1990

COMPLETE SPECIFICATION

FOR A STANDARD PATENT.

ORIGINAL

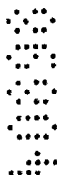

Name of Applicant: NAVSYS CORPORATION



Actual Inventors: Alison K. BROWN and Mark A. STURZA



Address of Service: SHELSTON WATERS
60 MARGARET STREET
SYDNEY NSW 2000

Invention Title: A SENSOR FOR USE IN A TRACKING SYSTEM EMPLOYING
GLOBAL POSITIONING SYSTEM SATELLITES

Details of Original Application No. 14997/92 dated 16th April, 1992

The following statement is a full description of this invention, including the best method of performing it known to us:-

A SENSOR FOR USE IN A TRACKING SYSTEM EMPLOYING GLOBAL
POSITIONING SYSTEM SATELLITES

Background and Summary of the Invention

This invention relates generally to navigation systems and more specifically to a

5 system for tracking vehicles and other objects on or near the earth's surface using
satellites of the Global Positioning System (GPS) and a sensor for use in such systems.

The GPS is a multiple-satellite based radio positioning system in which each GPS
satellite transmits data that allows a user to precisely measure the distance from selected
ones of the GPS satellites to his antenna and to thereafter compute position, velocity, and
10 time parameters to a high degree of accuracy, using known triangulation techniques.

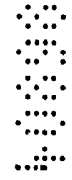

The signals provided by the GPS can be received both globally and continuously. The
GPS comprises three major segments, known as the space, control, and user segments.



The space segment, when fully operational, will consist of twenty-one
operational satellites and three spares. These satellites will be positioned in a
15 constellation such that typically seven, but a minimum of four, satellites will be



observable by a user anywhere on or near the earth's surface. Each satellite transmits
signals on two frequencies known as L1 (1575.42 MHz) and L2 (1227.6 MHz), using
spread spectrum techniques that employ two types of spreading functions. C/A and P
pseudo random noise (PRN) codes are transmitted on frequency L1, and P code only is
20 transmitted on frequency L2. The C/A or coarse/acquisition code, is available to any
user, military or civilian, but the P code is only available to authorized military and
civilian users. Both P and C/A codes contain data that enable a receiver to determine the
range between a satellite and the user. Superimposed on both the P and C/A codes is the
navigation (Nav) message. The Nav message contains 1) GPS system time; 2) a



handover word used in connection with the transition from C/A code to P code tracking; 3) ephemeris data for the particular satellites being tracked; 4) almanac data for all of the satellites in the constellation, including information regarding satellite health, coefficients for the ionospheric delay model for C/A code users, and coefficients used to calculate universal
5 coordinated time (UTC).

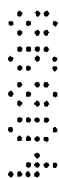

The control segment comprises a master control station (MCS) and a number of monitor stations. The monitor stations passively track all GPS satellites in view, collecting ranging data and satellite clock data from each satellite.



10 This information is passed on to the MCS where the satellites' future ephemeris and clock drift are predicted. Updated ephemeris and clock data are uploaded to each satellite for re-transmission in each satellite's navigation message. The purpose of the control segment is to ensure that the information transmitted from the satellites is as accurate as possible.



15 GPS is intended to be used in a wide variety of applications, including space, air, sea, and land vehicle navigation, precise positioning, time transfer, attitude reference, surveying, etc. GPS will be used by a variety of civilian and military organizations all over the world. A number of prior art GPS receivers have been developed to meet the needs of the diverse group of
20 users. These prior art GPS receivers are of a number of different types, including sequential tracking, continuous reception, multiplex, all in view, time transfer, and surveying receivers.



A GPS receiver comprises a number of subsystems, including an antenna assembly, an RF assembly, and a GPS processor assembly. The antenna assembly
25 receives the L-band GPS signal and amplifies it prior to insertion into the RF

assembly. A significant factor affecting the accuracy of the computed position, velocity or time parameters is the positional geometry of the satellites selected for measurement of ranges. Generally, the best position solution is obtained using satellites having wide angles of separation. Considerable
5 emphasis has therefore been placed on designing antenna systems to receive, with uniform gain, signals from any point on the hemisphere. This design approach tends to result in an expensive antenna assembly.

The RF assembly mixes the L-band GPS signal down to a convenient IF frequency. Using various known techniques, the PRN code modulating the L-band
10 signal is tracked through code-correlation to measure the time of transmission of the signals from the satellite. The doppler shift of the received L-band signal is also measured through a carrier tracking loop. The code correlation and carrier tracking function can be performed using either analog or digital processing.

The control of the code and carrier tracking loops is provided by the GPS
15 processor assembly. By differencing this measurement with the time of reception, as determined by the receiver's clock, the pseudo range between the receiver and the satellite being tracked may be determined. This pseudo range includes both the range to the satellite and the offset of the receiver's clock
20 from the GPS master time reference. The pseudo range measurements and navigation data from four satellites are used to compute a three dimensional position and velocity fix, to calibrate the receiver's clock offset, and to provide an indication of GPS time.

In some known receivers, the receiver processor controller (RPC)
25 functions are performed using a computer separate from that on which the

navigation functions are performed. In other known receivers, both types of functions are performed by a single computer. The RPC processing and memory functions that a typical GPS receiver performs include monitoring channel status and control, signal acquisition and reacquisition, code and carrier tracking
5 loops, computing pseudo range (PR) and delta range (DR) measurements, determining data edge timing, acquisition and storage of almanac and ephemeris data broadcast by the satellites, processor control and timing, address and command decoding, timed interrupt generation, interrupt acknowledgment control, and GPS timing, for example. These functions are fixed point operations and do
10 not require a floating point coprocessor.

The navigation processing and memory functions performed by a typical GPS receiver include satellite orbit calculations and satellite selection, atmospheric delay correction calculations, navigation solution computation, clock bias and rate estimates, computation of output information, and pre-
15 processing and coordinate conversion of aiding information, for example. These functions require significant amounts of processing and memory and are generally performed using a floating point coprocessor.

The GPS standard positioning service provides a navigation accuracy of 100 m 2dRMS. A number of applications of the GPS require higher levels of
20 accuracy. Accuracy can be improved using a technique known as differential GPS (DGPS). This technique involves operating a GPS receiver in a known location. The receiver is used to compute satellite pseudo range correction data using prior knowledge of the correct satellite pseudo ranges, which are then broadcast to users in the same geographic area. The pseudo range corrections are
25 incorporated into the navigation solution of another GPS receiver to correct the

observed satellite pseudo range measurements, thereby improving the accuracy of the position determination. Correlation of the errors experienced at the reference station and at the user location is dependent on the distance between them, but they are normally highly correlated for a user within 350 kilometers of the reference station.

An alternative to the GPS receiver known in the prior art is the GPS translator, which includes only the antenna assembly and RF assembly portions of a GPS receiver. Translators are typically employed in missile tracking applications where small, lightweight, expendable sensors are required. The GPS C/A code spread spectrum signals received by the translator are combined with a pilot carrier and transmitted at S-band frequencies (2200 to 2400 MHz). A GPS translator processor located at the telemetry tracking site receives these translated GPS C/A code signals and estimates the position and velocity of the vehicle.

Known variants of the GPS translator are the digital translator and the transdigitizer. A vehicle-borne GPS digital translator or transdigitizer operates to convert the GPS C/A code spread spectrum signals to base band and perform in-phase and quadrature phase sampling at a rate of about 2 MHz. Transdigitized GPS signals in a ground based translator processing system are processed much like GPS signals.

In summary, prior art GPS receivers may be one of two types. In the first type, all navigation processing activities occur at the receiver, which outputs the vehicle position and velocity using either a single computer or an RPC and navigation computer, in which there is substantial interconnection between the RPC functions and the navigation functions for satellite selection

and acquisition. In the second type of GPS receiver, the GPS signal is remoted by translation or variations thereof and the signal is tracked at a ground processing facility where the vehicle position and velocity are derived. In accordance with this latter approach, significant bandwidth is required to transmit the translated signal.

5 According to one aspect of the invention there is provided a sensor mounted on each of a multiplicity of objects to be tracked in a tracking system employing global positioning system (GPS) satellites, the sensor comprising:

antenna means for receiving signals from one or more GPS satellites;

RF/IF means for receiving signals from said antenna means and for converting
10 those signals to digital samples, said RF/IF means comprising preamplifier means for receiving and amplifying an L1 radio frequency signal having a nominal carrier frequency of 1575.42 MHz, a reference oscillator operating at a frequency FO, phase locked loop means for generating a single local oscillator signal at a frequency $256*FO$, mixer means for receiving said L1 radio frequency signal from the preamplifier means,
15 said mixer means being responsive to the local oscillator signal for reducing the signal output of the preamplifier means to an intermediate frequency signal having a frequency of $1575.42 - 256*FO$ MHz, low pass filter means for filtering the intermediate frequency signal provided by said mixer means, and digitizer means for digitizing the filtered intermediate frequency signal provided by said low pass filter means;

20 digital signal processing (DSP) means coupled to said RF/IF means for converting those digital samples to processed digital signals;



a crystal oscillator coupled to said RF/IF means and to said DSP means for generating a local oscillator signal and providing that local oscillator signal to said RF/IF means and to said DSP means; and

microcomputer means coupled to said DSP means for computing, from said
5 signals received from one or more GPS satellites, sensor data comprising selected raw satellite measurements to be transmitted to a remotely located workstation for computation of the position and velocity of the object on which the sensor is mounted.

According to another aspect of the invention there is provided a sensor mounted on each of a multiplicity of objects to be tracked in a tracking system employing global
10 positioning system (GPS) satellites, the sensor comprising:

antenna means for receiving signals from one or more GPS satellites;

RF/IF means for receiving signals from said antenna means and for converting those signals to digital samples;

digital signal processing (DSP) means coupled to said RF/IF means for converting
15 those digital samples to processed digital signals, said DSP means comprising a pair of exclusive OR gates for performing code correlation on a signal received from said RF/IF input means and for performing carrier demodulation employed in generating in phase and quadrature signals I and Q, a pair of up/down counters coupled to said pair of exclusive OR gates for accumulating the in phase and quadrature signals I and Q, a C/A
20 coder coupled to said pair of exclusive OR gates for generating a coarse acquisition code from a signal indicative of a satellite being tracked, a code phase numerically controlled oscillator coupled to said C/A coder for indexing said C/A coder, a carrier numerically controlled oscillator coupled to said pair of exclusive OR gates, for receiving a DSP clock signal derived by dividing reference oscillator frequency FO, and for generating



the in phase and quadrature signals I and Q, and memory map interface means coupled to said microcomputer means for receiving the in phase and quadrature signals I and Q and for generating a plurality of control signals therefrom;

a crystal oscillator coupled to said RF/IF means and to said DSP means for
5 generating a local oscillator signal and providing that local oscillator signal to said RF/IF means and to said DSP means; and

microcomputer means coupled to said DSP means for computing, from said signals received from one or more GPS satellites, sensor data comprising selected raw satellite measurements to be transmitted to a remotely located workstation for
10 computation of the position and velocity of the object on which the sensor is mounted.

A preferred embodiment of the invention provides a GPS sensor module that supplies the data required to locate a particular vehicle, a two-way vehicle location system (VLS) communication link, and a VLS workstation to process the data and display the vehicle location. The GPS sensor module comprises an antenna and a sensor.
15 The sensor operates autonomously following initialization by the network management facility. The sensor sequences through the visible GPS satellites, making pseudo range (PR) and delta range (DR) or time difference (TD) and frequency difference (FD) measurements. No navigation functions are performed by the sensor, thereby permitting significant reductions in the cost thereof. The raw satellite measurements, with relevant
20 timing and status information, are provided to the VLS communication link to be relayed periodically back to the VLS workstation. Using this set of raw satellite measurements, the location of the sensor can be determined to a precision of 100 meters. If differential corrections are also provided at the VLS workstation, the accuracy of the vehicle



location determination can be improved to better than 10 meters. In normal operation, three satellite measurements are required to compute the location of the vehicle, but for a short time period a minimum of two satellite measurements are acceptable with time, altitude, and map aiding information being provided from the VLS workstation. The principal advantage afforded by the present invention is its ability to provide extremely accurate position, velocity, and time information for vehicles, including those in high rise urban areas, using a low cost vehicle sensor and any mobile radio communication system or information system. By eliminating the navigation functions performed in prior art GPS sensors, a low cost computer may be used, thereby providing a significant cost reduction over existing GPS receiver designs.



In a preferred embodiment the invention provides a low cost tracking system for vehicles and other objects, using GPS satellites, that is capable of tracking several hundred vehicles or platforms using a low bandwidth data link.

Also in a preferred embodiment the invention provides a low cost vehicle tracking system, using GPS satellites, that has the ability to function accurately in high rise urban areas by employing an antenna system optimized for high elevation satellites and by employing mapping aiding functions in a VLS workstation to reduce the number of satellites that the system is required to receive for short periods of time.

It is an object of the present invention to overcome or ameliorate at least one of the disadvantages of the prior art, or to provide a useful alternative.

Unless the context clearly requires otherwise, throughout the description and the claims, the words 'comprise', 'comprising', and the like are to be construed in an inclusive sense as opposed to an exclusive or exhaustive sense; that is to say, in the sense of "including, but not limited to".



Brief Description of the Drawings

Figure 1 is a block diagram illustrating the primary components of the GPS vehicle tracking system of the present invention.

Figure 2 is block diagram of the sensor employed in the GPS vehicle tracking system of Figure 1.

Figure 3 is a block diagram of the RF/IF section of the sensor of Figure 2.

Figure 4 is a block diagram of the digital signal processor chip (DSP) of the sensor of Figure 2.

Figure 5 is a flow chart of the process employed to determine vehicle position using the GPS vehicle tracking system of Figure 1.



Detailed Description of an Embodiment of the Invention

The present invention is directed to a tracking system for computing the position and velocity of multiple low cost vehicle-mounted sensors, monitored and tracked by a central control station and more particularly, to a sensor for use in such a system. In the present invention, the receiver processor functions are physically separated from the navigation functions, and a low rate data interface is provided between the computers that perform these functions. This separation of receiver processor and navigation functions results in a significant cost saving in the GPS sensor that is employed on board each vehicle. The GPS sensor provides GPS satellite measurements on a periodic basis through a conventional bandwidth radio communication link to a master station. The GPS sensor data is transmitted on periodic basis at low data rates, thereby permitting the use of conventional transmission paths capable of handling data at the rate of 300 bits/second. Thus, data can be transmitted from large numbers of vehicles using conventional radio facilities. The master station computes the vehicle position for all users of the system, and large numbers of vehicle solutions can be processed simultaneously by the master station by exploiting the commonality in satellite geometry for all sensors tracking the same satellites in a common area having radius on the order of 100 kilometers. The master station down loads initialization data such as initial position estimates or a satellite selection table to each sensor on a periodic daily or monthly basis over a conventional radio communication link. The differential GPS accuracy is achieved for each sensor by use of a reference GPS receiver located at the master station. The use of altitude, map, and time aiding at the master station reduces some of the satellite geometry requirements, thereby permitting the use of high elevation



satellites only as a way to simplify satellite acquisition, increase service availability, and reduce the cost of the antenna system.

Referring now to the block diagram of Figure 1, the vehicle tracking system of the present invention primarily comprises an antenna 10, a sensor 20, a communication link 30, a VLS workstation 40, and a GPS reference receiver 60.

Antenna 10 may comprise any of a number of commercially available low-gain, low-cost antennas, the use of which is made possible as the result of only requiring high elevation satellites in the system implementation. This also simplifies satellite acquisition and permits operation of the vehicle tracking system in high rise urban areas.

A representative implementation of sensor 20 employs a simplified method of frequency synthesis, a temperature compensated crystal oscillator (TCXO) 21 or other low cost oscillator, a simplified digital signal processor (DSP) 22, and reduced computational processing. Detailed block diagrams of sensor 20 are shown in Figures 2 and 3. Frequency synthesis within sensor 20 is based on an oscillator frequency (F0) of 6.1539 MHz that is produced by temperature compensated crystal oscillator 21. A local oscillator frequency (LO), produced by local oscillator 23, is $256 \times F0 = 1575.3984$ MHz. The power of 2 multiplier (256) simplifies the design of a phase lock loop (PLL) 25 that is employed to lock the frequency of the local oscillator 23 to that of the crystal oscillator 21. The resulting intermediate frequency (IF) is $1575.42 \text{ MHz} - 256 F0 = 21.6$ KHz. This IF is far enough above DC to allow distinction between positive and negative doppler shifts. It is also close enough to DC to result in minimal post correlation noise increase due to spectral noise folding. The sampling clock used by the DSP chip 22 is $F0/3 = 2.01513$ MHz, a frequency that is ideal

in that it is not related to the 1.023 MBS chip rate. A conventional microcomputer 24 is used that requires only fixed point operation. Sensor 20 may be configured with from one to eight DSP channels 22, depending on the particular application. Each of DSP channels 22, the details of which are
5 illustrated in Figure 4, comprises a custom gate array that performs the C/A code correlation and removes the L-band signal doppler shift on the digital GPS signals. The residual in-phase (I) and quadrature (Q) signals are accumulated over 1 millisecond for early, late, and prompt code phase and are provided to a microcomputer for signal tracking. The tracking microcomputer is used to select
10 the GPS satellite to be tracked and to close the code and carrier tracking loops.

Microcomputer 24 of sensor 20 may comprise any of a number of commercially available microcomputers, depending on the application and system requirements. A minimum system configuration requires a Z80 microcomputer or
15 equivalent to perform signal tracking and to control the operation of sensor 20. Other applications that involve multichannel processing and high performance navigation may require a more powerful microcomputer that may comprise an existing host system microcomputer, if appropriate.

The details of operation of the digital signal processing chip 22 of
20 Figure 2 may be understood with reference to the detailed block diagram of Figure 4. A pair of exclusive OR gates 71 and 72 serve to perform code correlation on the input signal and also to perform carrier demodulation to generate the in phase and quadrature signals I and Q. A pair of up/down
counters 76 and 77 serve to accumulate the in phase and quadrature signals I and
25 Q. A C/A coder 73 generates coarse acquisition code from input signals G1 and

G2. G1 is a 10-bit signal received from a memory map interface 74 that determines which satellite is being tracked. Memory map interface 74 is coupled to micro computer 24 of Figure 2 and generates a number of signals from the in phase and quadrature input signals I and Q. A code phase numerically controlled oscillator (NCO) 75 receives a signal TAU from memory map interface 74 that serves to increment code phase NCO 75 to, in turn, index C/A coder 73. A carrier NCO 78 is initialized by phase PH and estimate delta phase EDP signals received from memory map interface 74 and, in turn, generates the in phase I and quadrature Q signals used to perform carrier demodulation. Carrier NCO 78 is clocked by a signal that is 1/30 of the frequency of a DSP clock signal. A 1 ms. interrupt signal INTP is derived from the DSP clock signal and serves to signal micro computer 24 that data is available.

Data and commands are transferred between sensor 20 and communication link 30 via a conventional data link 31 capable of handling a data rate of 300 bits per second. Exemplary of the conventional communication links that may be employed for this purpose are two-way paging systems, private mobile radio, citizens band radio, cellular radio, personal communications systems, trunked mobile radio systems, local area mobile radio systems, and military communications systems.

VLS workstation 40 operates to receive the GPS sensor data through communication link 30 and to compute the vehicle (sensor 20) location. The location is then displayed to the customer superimposed on a map of the region. VLS workstation 40 also serves as a communications interface by receiving data from sensor 20, identifying the vehicle being tracked, and passing the appropriate data to the navigation function for processing. In addition, VLS

workstation 40 serves to control sensor 20 by transmitting initialization data to sensor 20 and by requesting status data therefrom. The initialization data may comprise a reporting interval, satellite selection, and current position information. VLS workstation 40 may also serve to compute the position of the
5 GPS satellites using data from a reference receiver 60. Optionally, VLS workstation 40 may be employed to derive a DGPS correction factor for the satellite measurements. It also computes the SV position to provide an estimated PR or TD measurement to the median location for each GPS satellite visible from the area of operation. VLS workstation 40 computes an observation
10 matrix for a median location in the area of operation. This matrix may be derived from the line of sight vectors to each satellite. A navigation algorithm is employed to compute the measurement residuals from the data received from each of the vehicle sensors 20 and the SV correction data. These measurement residuals are processed by VLS workstation 40 using the data from
15 the observation matrix computation to derive the vehicle offset from a median location. Using this approach, accurate vehicle positions may be calculated over a 100-kilometer area using the navigation algorithm. An aided navigation solution may be computed by VLS workstation 40 for sensors 20 that report data from less than four satellites. The vehicle altitude may then be estimated from
20 a digital map and used to compute a solution using only three satellites. Information regarding direction of travel may be included to estimate a solution for a short period of time during which data from fewer than three satellites is provided. Finally, VLS workstation 40 is operative for visually displaying the locations of the vehicles on which sensors 20 are positioned to the user. Hard
25 copy reports that provide this information may also be generated, and this

information may also be integrated with conventional routing software, for example.

Referring now to the system block diagram of Figure 1 and to the flow chart of Figure 5, data from sensor 20 is first retrieved from the communication link 30 and stored in memory. At steps 2, 13, and 14, the satellite position is computed for each satellite in view of the region of coverage as determined from the satellite visibility table derived on a periodic (hourly, for example) basis from reference receiver 60. At step 3, the satellite positions and clock calibration coefficients are used to compute the estimated pseudo range (range and clock bias) to the median location. The line-of-sight vectors are also determined to this location. At step 4, differential GPS corrections received from GPS reference receiver 60 are added to the estimated pseudo range to correct for atmospheric effects and errors in the satellite position and clock offsets. At step 5, the line-of-sight vectors determined at step 3 are used to compute a least squares transformation matrix H^* for all sets of satellites tracked by the sensors 20 in the region covered. The measurement residual vectors are then computed at step 6 by differencing the received measurements from the estimated measurements derived at step 4. The estimated altitude offset of the vehicle from the median location is also included as a measurement residual. In cases where fewer than three satellite measurements are available, data aiding from a knowledge of the vehicle route (direction of travel) derived from the digital map 15 may also be included. In order to compute the location of each of sensors 20 at step 7, the measurement residual vectors derived at step 6 are then multiplied by the appropriate transformation matrix H^* derived at step 5 to calculate the offset from the median location. If the location

derived does not correspond with a possible solution (i.e. does not lie in a valid region of the digital map 15), the location is recomputed using an updated altitude offset and route aiding from the digital map 15. At step 8, the locations of sensors 20 are displayed to the operator, overlaid on a map of the region. 5
Optionally, at step 9, the position of each of sensors 20 may also be rebroadcast back to a particular sensor through the communication link 30 if requested at step 11. The position information may be in terms of an offset coordinate or as a street location derived, at step 10, from the digital map. At step 12, VLS workstation 70 periodically updates the sensors 20 with 10
initialization data on satellites to be tracked using information derived from the visibility table.

While the preferred embodiment of the GPS tracking system of the present invention has been described above in connection with ground-based vehicles, it should be understood that the tracking system of the present invention may be 15
employed to track sea-based (both surface and underwater) and air-based vehicles (e.g. balloons, conventional aircraft, and satellites), as well as personnel, and even animals, for example.

THE CLAIMS DEFINING THE INVENTION ARE AS FOLLOWS:-

1. A sensor mounted on each of a multiplicity of objects to be tracked in a tracking system employing global positioning system (GPS) satellites, the sensor comprising:

antenna means for receiving signals from one or more GPS satellites;

5 RF/IF means for receiving signals from said antenna means and for converting those signals to digital samples, said RF/IF means comprising preamplifier means for receiving and amplifying an L1 radio frequency signal having a nominal carrier frequency of

1575.42 MHz, a reference oscillator operating at a frequency FO, phase locked loop means for generating a single local oscillator signal at a frequency $256*FO$, mixer means for

10 receiving said L1 radio frequency signal from the preamplifier means, said mixer means

being responsive to the local oscillator signal for reducing the signal output of the

preamplifier means to an intermediate frequency signal having a frequency of $1575.42 -$

$256*FO$ MHz, low pass filter means for filtering the intermediate frequency signal

provided by said mixer means, and digitizer means for digitizing the filtered intermediate

15 frequency signal provided by said low pass filter means;

digital signal processing (DSP) means coupled to said RF/IF means for converting those digital samples to processed digital signals;

a crystal oscillator coupled to said RF/IF means and to said DSP means for

generating a local oscillator signal and providing that local oscillator signal to said RF/IF

20 means and to said DSP means; and

microcomputer means coupled to said DSP means for computing, from said signals received from one or more GPS satellites, sensor data comprising selected raw satellite measurements to be transmitted to a remotely located workstation for computation of the position and velocity of the object on which the sensor is mounted.



2. A sensor as in claim 1 wherein said crystal oscillator comprises a temperature compensated crystal oscillator.

3. A sensor as in claim 1 wherein said crystal oscillator comprises a temperature controlled crystal oscillator.

5 4. A sensor as in claim 1 wherein said digitizer comprises a limiter.

5. A sensor as in claim 1 wherein said DSP means comprises a plurality of individual DSP circuits on a single semiconductor chip, each of said plurality of individual circuits comprising:

a pair of exclusive OR gates for performing code correlation on a signal received
10 from said RF/IF input means and for performing carrier demodulation employed in generating in phase and quadrature signals I and Q;

a pair of up/down counters coupled to said pair of exclusive OR gates for accumulating the in phase and quadrature signals I and Q;

a C/A coder coupled to said pair of exclusive OR gates for generating a coarse
15 acquisition code from a signal indicative of a satellite being tracked;

a code phase numerically controlled oscillator coupled to said C/A coder for indexing said C/A coder;

a carrier numerically controlled oscillator coupled to said pair of exclusive OR gates, for receiving a divided DSP clock signal, and for generating the in phase and quadrature
20 signals I and Q; and

memory map interface means coupled to said microcomputer means for receiving the in phase and quadrature signals I and Q and for generating a plurality of control signals therefrom.



6. A sensor as in claim 5 wherein the frequency FO at which said reference oscillator operates is 6.1539 MHz.

7. A sensor mounted on each of a multiplicity of objects to be tracked in a tracking system employing global positioning system (GPS) satellites, the sensor comprising:

5 antenna means for receiving signals from one or more GPS satellites;

RF/IF means for receiving signals from said antenna means and for converting those signals to digital samples;

digital signal processing (DSP) means coupled to said RF/IF means for converting those digital samples to processed digital signals, said DSP means comprising a pair of

10 exclusive OR gates for performing code correlation on a signal received from said RF/IF input means and for performing carrier demodulation employed in generating in phase and quadrature signals I and Q, a pair of up/down counters coupled to said pair of exclusive OR gates for accumulating the in phase and quadrature signals I and Q, a C/A coder coupled to said pair of exclusive OR gates for generating a coarse acquisition code from a signal

15 indicative of a satellite being tracked, a code phase numerically controlled oscillator coupled to said C/A coder for indexing said C/A coder, a carrier numerically controlled oscillator coupled to said pair of exclusive OR gates, for receiving a DSP clock signal derived by dividing reference oscillator frequency FO, and for generating the in phase and quadrature signals I and Q, and memory map interface means coupled to said

20 microcomputer means for receiving the in phase and quadrature signals I and Q and for generating a plurality of control signals therefrom;

a crystal oscillator coupled to said RF/IF means and to said DSP means for generating a local oscillator signal and providing that local oscillator signal to said RF/IF means and to said DSP means; and



microcomputer means coupled to said DSP means for computing, from said signals received from one or more GPS satellites, sensor data comprising selected raw satellite measurements to be transmitted to a remotely located workstation for computation of the position and velocity of the object on which the sensor is mounted.

5 8. A sensor as in claim 7 wherein the frequency of said reference oscillator signal FO is 6.1539 MHz and wherein said DSP clock signal is derived by dividing said reference oscillator signal FO by 3 to obtain a DSP clock signal whose frequency is 2.01513 MHz.

9. A sensor as in claim 7 wherein said DSP means comprises a plurality of individual DSP circuits on a single semiconductor chip.

10 10. A sensor as in claim 7 wherein said crystal oscillator comprises a temperature compensated crystal oscillator.

11. A sensor as in claim 7 wherein said crystal oscillator comprises a temperature controlled crystal oscillator.

15 12. A sensor for use in a tracking system, substantially as herein described with reference to Figures 2, 3 and 4 of the accompanying drawings.

DATED this

NAVSYS CORPORATION

Attorney: PETER R. HEATHCOTE
Fellow Institute of Patent Attorneys of Australia
of BALDWIN SHELSTON WATERS

20



11 01 30 4000

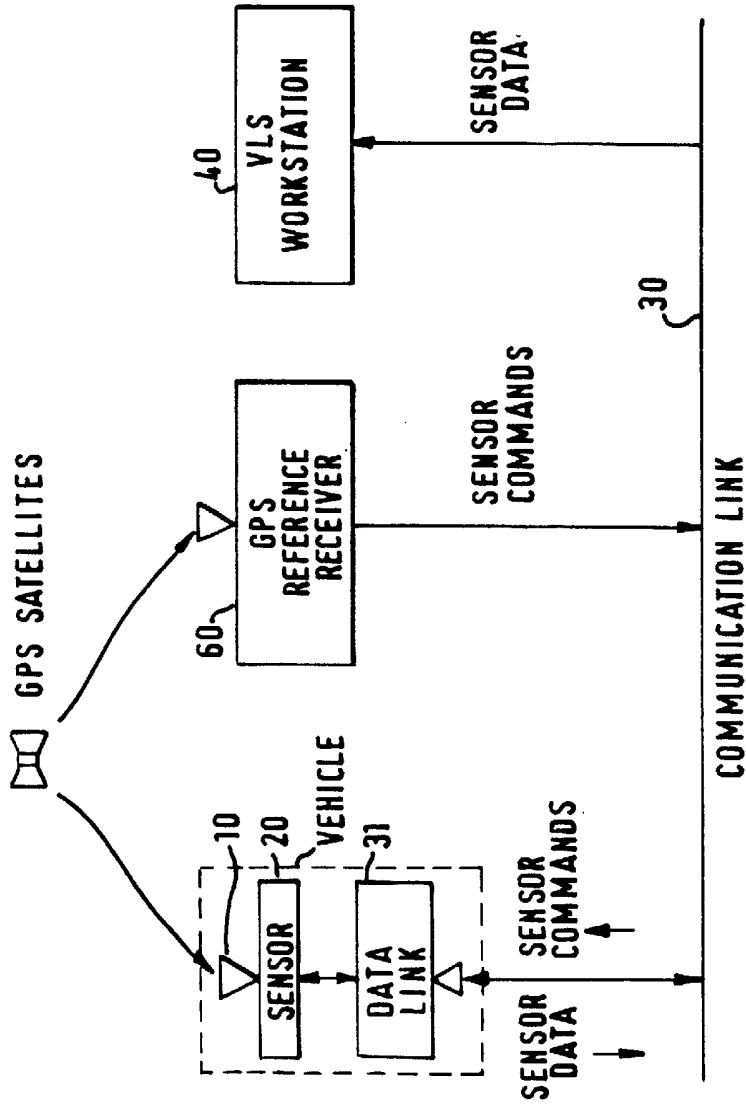
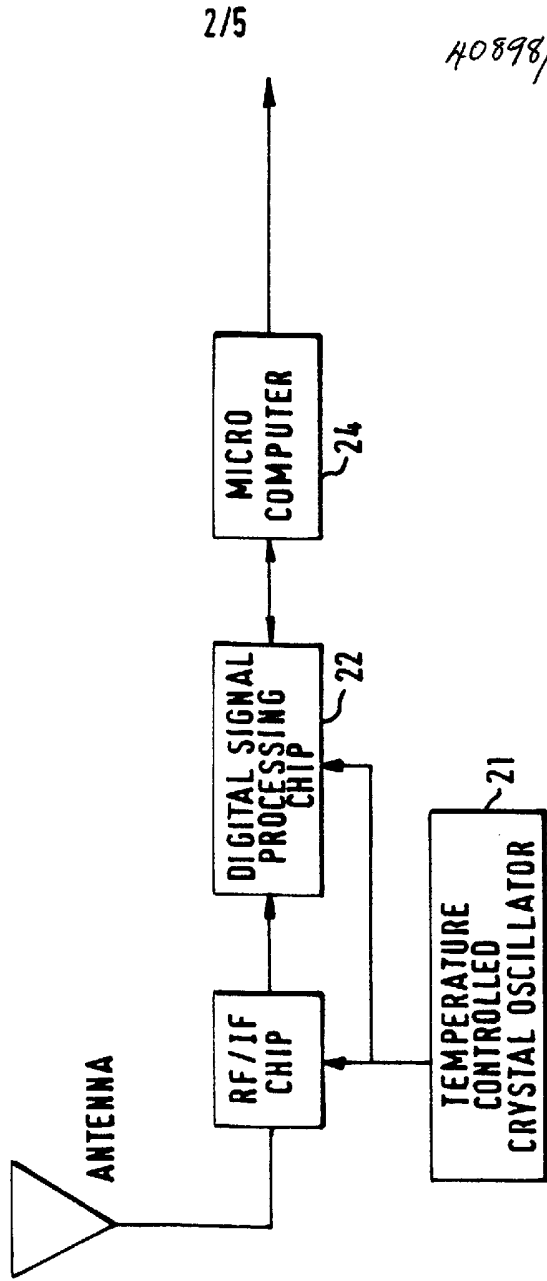

FIG.1

10 01 96 40898



40898/96

FIG. 2

10 01 35 4000

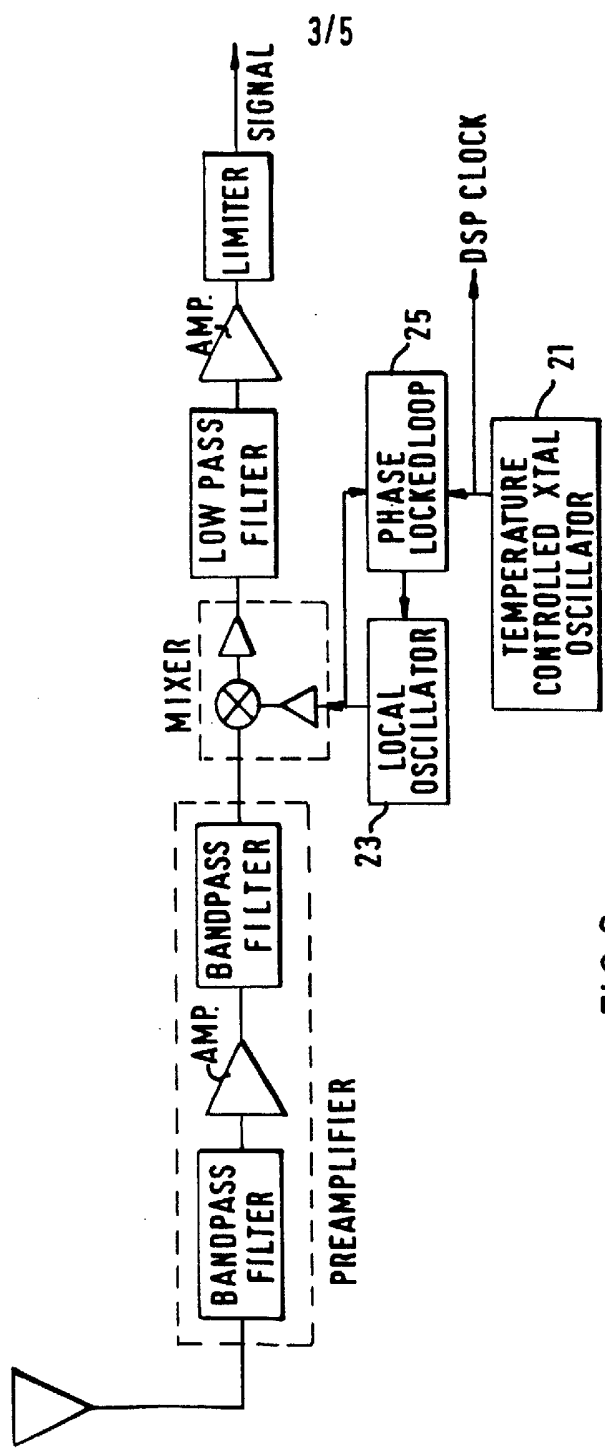

FIG.3

10 01 95 40000

DSP CHANNEL FUNCTIONAL BLOCK DIAGRAM

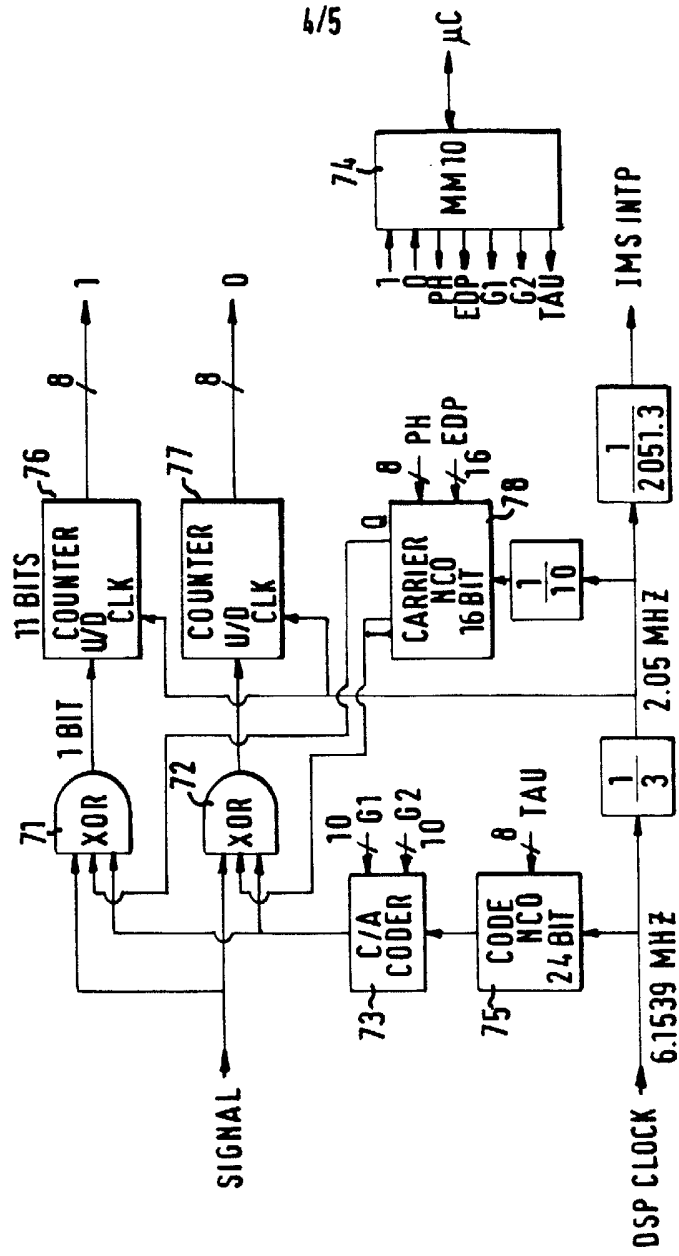

FIG. 4

6/5

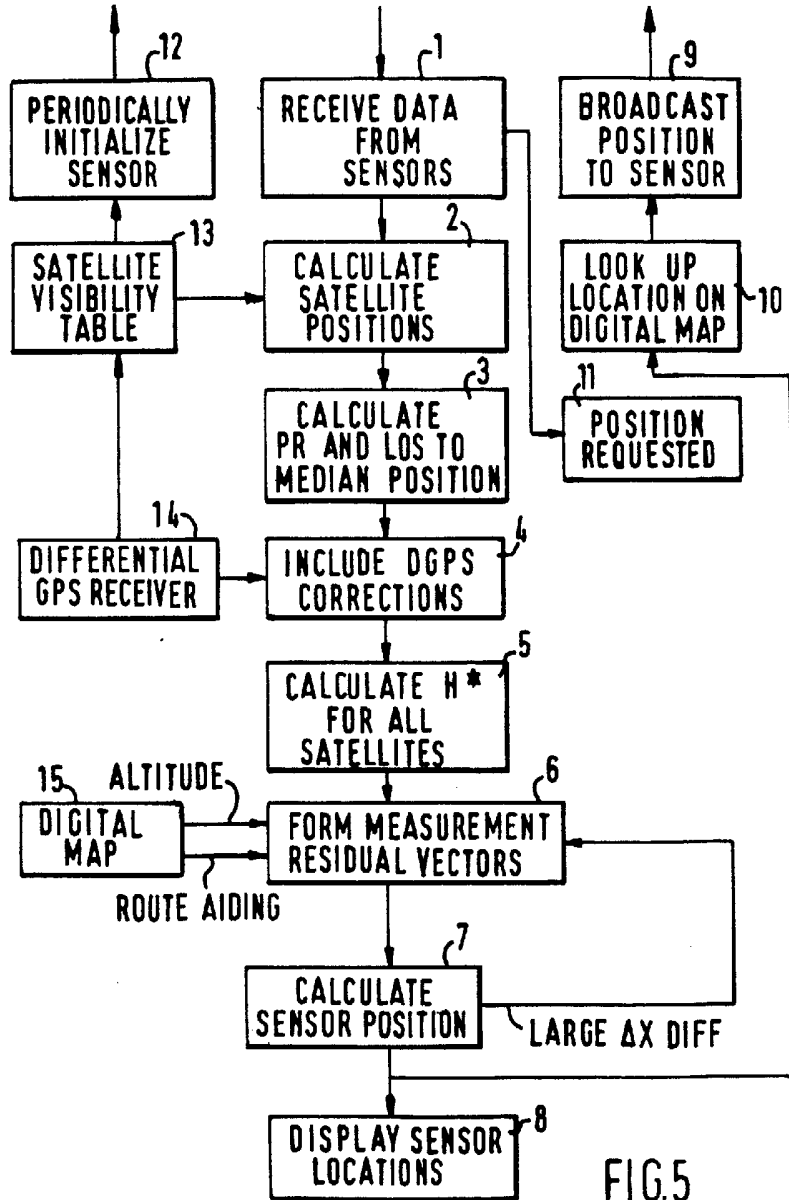

FIG.5