

(12) UK Patent Application (19) GB (11) 2 338 100 (13) A

(43) Date of A Publication 08.12.1999

(21) Application No 9913214.4
(22) Date of Filing 07.06.1999
(30) Priority Data
(31) 9812229 (32) 05.06.1998 (33) GB

(71) Applicant(s)
Tesco Stores Limited
(Incorporated in the United Kingdom)
Cirrus Building, Shire Park, WELWYN GARDEN CITY,
Herts, AL7 1SQ, United Kingdom

(72) Inventor(s)
Jeremy George Lindley

(74) Agent and/or Address for Service
Reddie & Grose
16 Theobalds Road, LONDON, WC1X 8PL,
United Kingdom

(51) INT CL⁶
G06K 17/00, G07F 19/00

(52) UK CL (Edition Q)
G4H HJ HTG H1A H13D H14A
U1S S1727 S2132

(56) Documents Cited
US 5641039 A US 5437346 A

(58) Field of Search
UK CL (Edition Q) A4L LAAK, G4H HJ
INT CL⁶ A47F, G06K, G07G
ONLINE:WPI,EPODOC,JAPIO

(54) Abstract Title
Check-out apparatus

(57) Self-service check-out apparatus for use by a customer at a store includes in an upright cabinet (12), a bar code scanning device (16) for scanning bar codes on goods to be purchased, a touch-sensitive display monitor (18) for displaying to the customer information concerning the scanned goods, a card-reading payment device (20) for receiving payment from the customer, and a bag dispensing station (22) for dispensing carrier bags into which the customer may place the scanned goods. A shelf (28) is provided to support the shopper's basket with a space for empty baskets (32) beneath it. The arrangement is easy for the shopper to use and is highly compact.

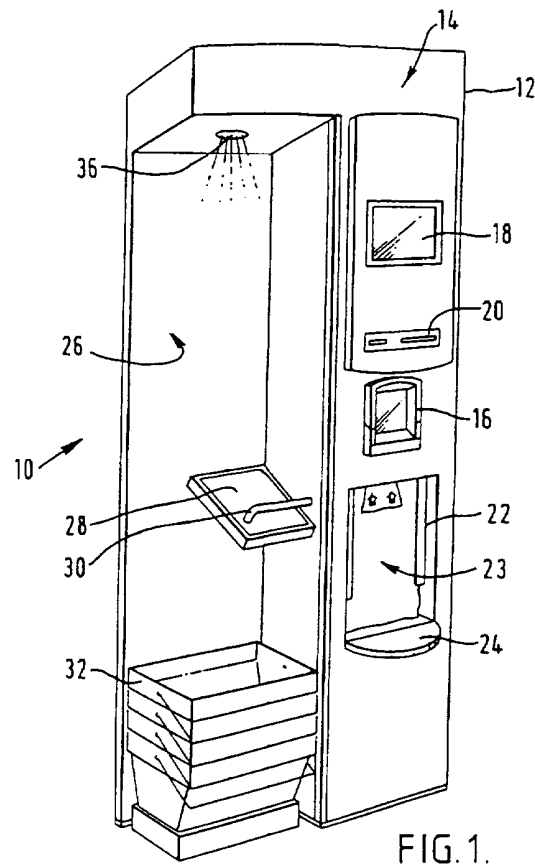

GB 2 338 100 A

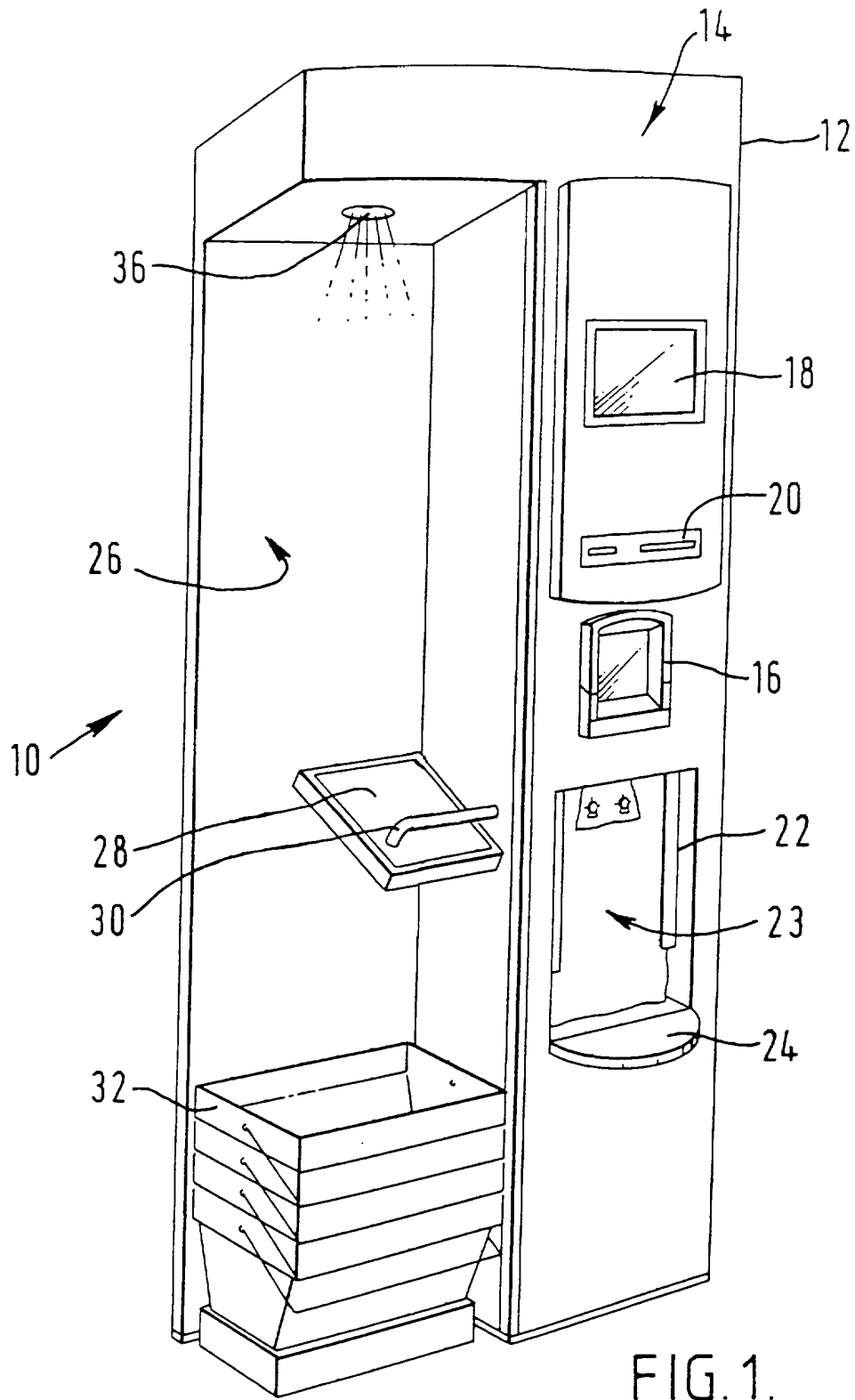

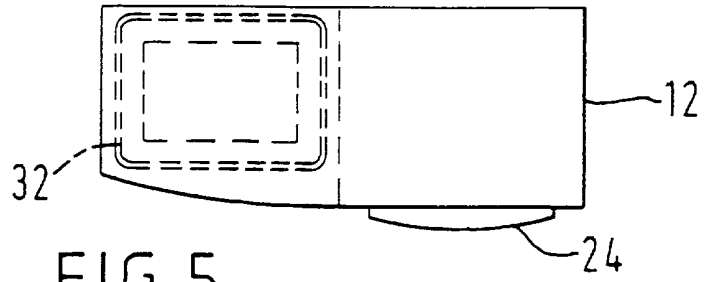

FIG. 5.

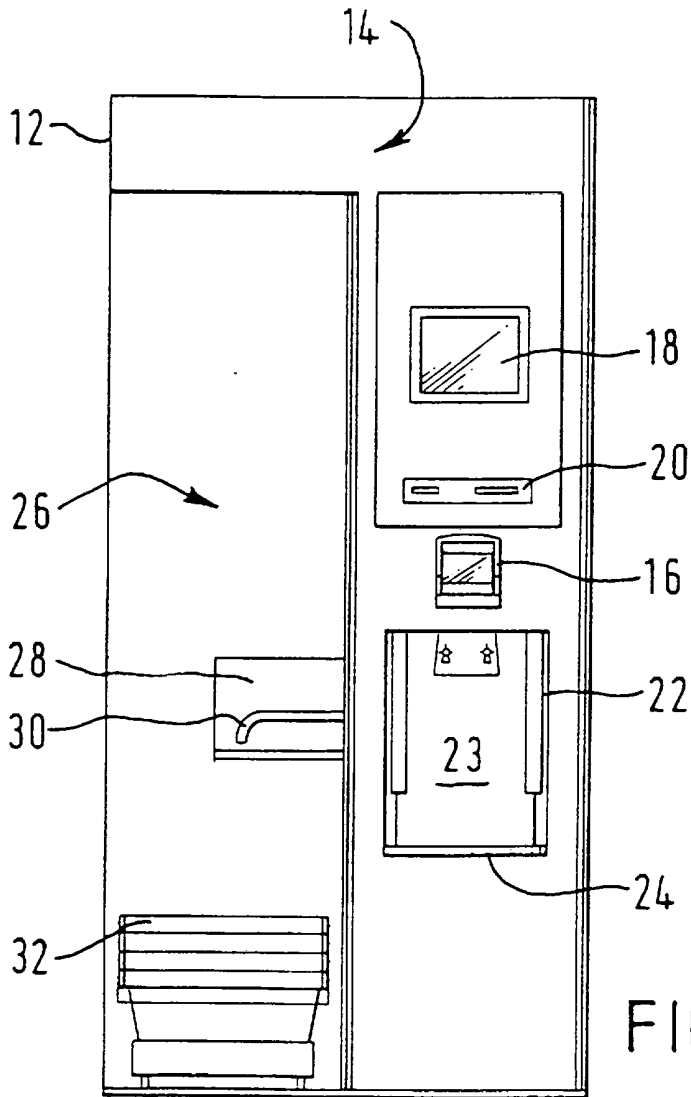

FIG. 2.

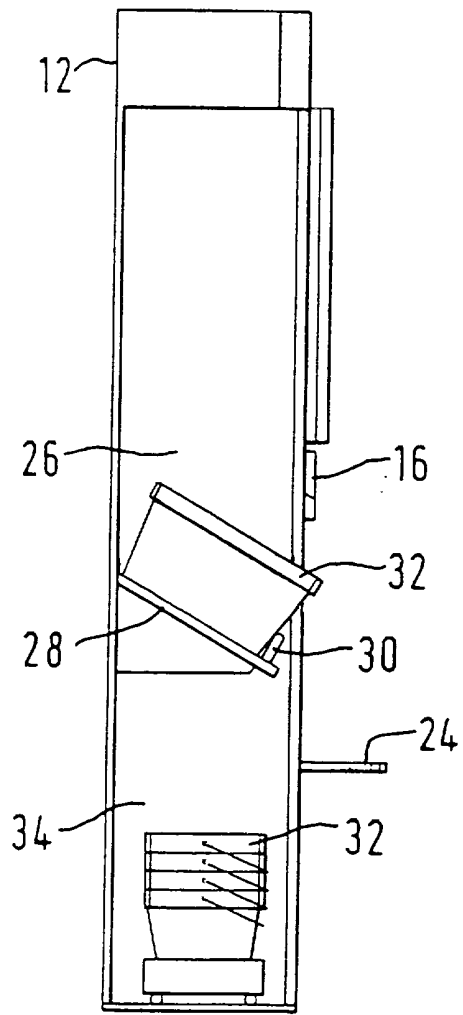

FIG. 3.

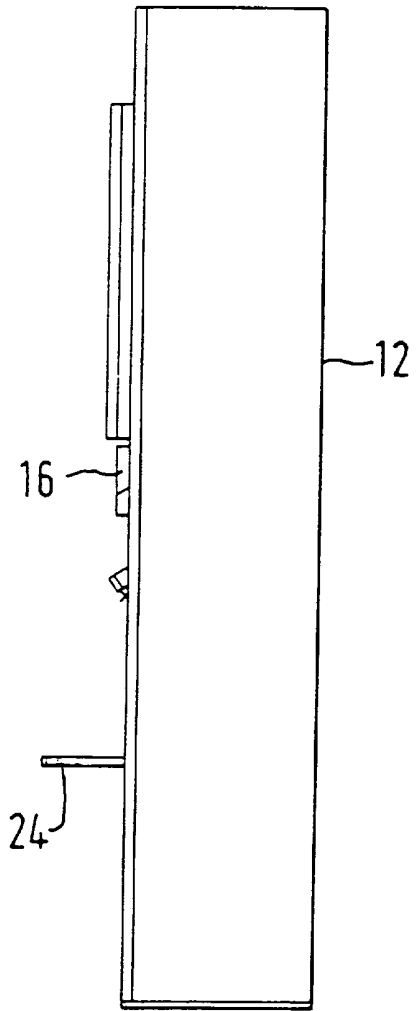

FIG. 4.

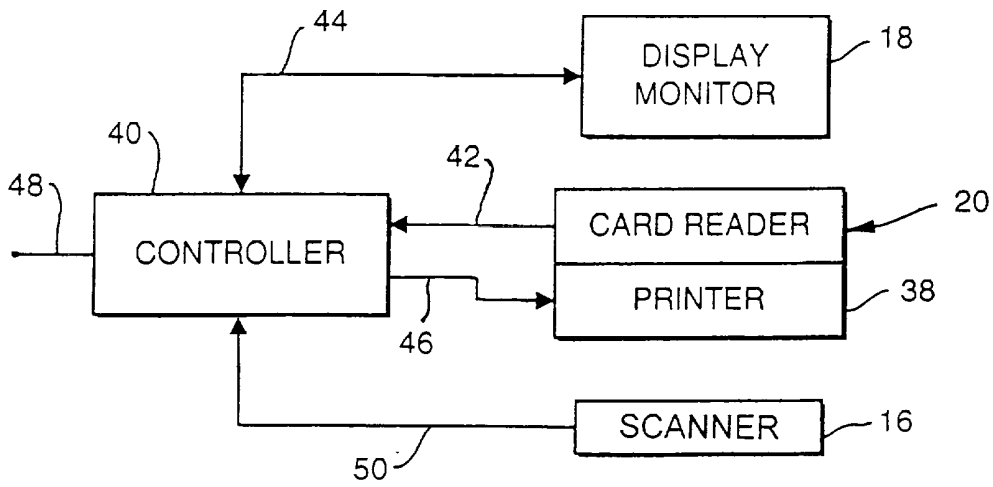

FIG. 6

CHECK-OUT APPARATUS

39816GB

Background of the Invention

The present invention concerns a check-out apparatus for use in retail establishments, and is particularly concerned with a customer-operated check-out apparatus.

Recent years have seen many changes to check-out systems in large retail stores such as supermarkets. Improvements such as the scanning of bar-codes on the goods have led to a speeding up of the process of paying for goods. Nevertheless, at busy times, many stores still have large queues at the check-out stations. To speed up the process further, some stores have introduced self-scanning, employing units which are portable or are mounted on a supermarket trolley for example, in which the customers are themselves responsible for the scanning of the bar-codes on their purchases.

However, there remains the need to make payment for the goods at a payment station under the control of a store operative, and this can lead to delays.

Smaller stores, usually located in cities and catering for shoppers wanting relatively few goods, have risen in popularity. By their nature, such stores appeal to customers who are in a hurry, for whom queues at the check-out are an unacceptable nuisance.

Examples of various approaches to the construction of check-out apparatus for use in retail establishments are to be found in: European Patent Applications EP-A-0 817 141; 0 811 958; 0 709 813; 0 673 006; 0 650 149; 0 638 883; 0 551 108; 0 498 311; and 0 491 348; United Kingdom Patent Applications GB-A-2,308,575; 2,286,275; and 2,252,188; United States Patent US-A-5,497,853; and International Patent Applications WO98/23195; WO85/04491; and WO93/24908. Despite these and many other attempts, no check-out apparatus for use in retail establishments has been proposed which is practical to use and yet which occupies a minimum of space in the establishment.

Summary of the Invention

According to the invention there is provided self service check-out apparatus for use by a customer at a store, the apparatus comprising scanning means for scanning codes on goods to be purchased, display means for displaying to the customer information concerning the scanned goods, payment receiving means for receiving payment from the customer, and bag dispensing means for dispensing carrier bags into which the customer may place the scanned goods; the scanning means, the display means, the payment receiving means, and the bag dispensing means being arranged as a unit.

In a preferred arrangement, the scanning means, display means, payment receiving means and bag dispensing means are all located integrally in an upright cabinet. The scanning means may comprise bar code scanning means for scanning bar codes printed on goods to be purchased. Preferably the display means comprises a display monitor for displaying information such as may identify the product scanned and its price, and/or for identifying the various stages in the payment transaction.

The apparatus may have interface means permitting the customer to interact with the apparatus. The interface means may comprise a touch-sensitive screen on the display monitor.

The payment receiving means may comprise an electronic card, magnetic card or smart card reader apparatus, for allowing the customer to make payment for purchased goods using e.g. a credit, debit, pre-payment or charge card. There may also be provided means for dispensing a printed receipt.

The apparatus may include automated cash dispensing means for enabling a customer to obtain cash in addition to the purchased goods.

Preferably the apparatus comprises a first shelf for supporting a shopping basket in use. The apparatus may comprise a second shelf located beneath and/or adjacent the bag dispensing means for supporting a bag as scanned goods are placed in the bag.

In a preferred arrangement the scanning means, the payment receiving means and the display means are located on a substantially upright surface of the cabinet.

Preferably the scanning means, the payment receiving means and the display means are all located above one another on the same substantially upright surface, such that the display means is disposed approximately at eye level, for an average standing customer, and the payment receiving means and the scanning means are disposed beneath the display means.

The cabinet may comprise a first recess for storing empty shopping baskets. The first shelf may be located in the first recess.

The bag dispensing means may be disposed beneath and/or to one side of the scanning means. Preferably the bag dispensing means is located in a second recess. The second recess may be formed in the substantially upright surface.

The apparatus may comprise a plurality of adjacent cabinets arranged side-by-side for several customers to operate simultaneously.

Brief Description of the Drawings

The present invention may be carried into practice in various ways but an embodiment will now be described by way of example only with reference to the accompanying diagrammatic drawings in which:

Figure 1 shows, in perspective view, self-service check-out apparatus according to a preferred embodiment of the present invention;

Figure 2 is a front view of the apparatus of Figure 1;

Figure 3 shows from one side, the apparatus of Figure 1;

Figure 4 is a view from the other side of the apparatus of Figure 1;

5 Figure 5 is a plan view of the apparatus of Figure 1; and

Figure 6 is a diagrammatic view of the electrical connections of the components of the apparatus.

Detailed Description of the Preferred Embodiment

10 Referring to Figures 1 to 5, there is shown generally a floor-standing fixed self-service check-out apparatus 10 comprising an upright rigid cabinet 12 constructed of wood, metal and plastics materials. The cabinet 12 has on an upright front facing surface 14 thereof a bar code scanning
15 device 16 for scanning bar codes printed on goods to be purchased, a touch sensitive display monitor 18 for displaying to the customer information concerning the scanned goods and for receiving customer inputs, a card reading payment device 20 for receiving payment cards and
20 including a printed receipt dispenser, and a bag dispensing station 22 for containing and dispensing plastic carrier bags supported conventionally at their tops by a rack arrangement (not shown) in a recess 23 of the cabinet. A shelf 24 is located directly below the bag dispensing
25 station, and protrudes slightly from the front facing surface 14.

The cabinet 12 also has another recess 26 to the side of the surface 14 in which is located a sloping shelf 28 with a steel integral retaining bar 30 for retaining a
30 shopping basket 32 positioned on the shelf 28. A light 36 may illuminate the contents of the basket on the shelf. Beneath the shelf 28 is a storage space 34 for storing further empty baskets 32. If desired, the apparatus can be provided with a vertical left-hand side panel.

In use, a customer places a basket 32 containing selected goods (not shown) to be purchased on the shelf 28. She or he then scans each of the items in the basket in turn, by passing their bar codes over the scanner 16, and places the scanned items in a bag held by the bag dispensing station 22. The bag remains suspended whilst being filled, and the shelf 24 below supports the weight of the goods in the bag. The display monitor displays information such as may identify the produce scanned and its price. Once all of the goods have been scanned, the customer makes payment by placing their credit, debit or charge card (which may be a magnetic stripe card or a smart card) in the card reader 20 and by entering payment related information, and making appropriate decisions, by interaction with the touch screen of the display monitor 18. During this operation the display monitor displays information identifying the various stages in the payment transaction.

Once payment has been made the card is returned to the customer and a receipt is printed and issued by the receipt printer. The customer then places their empty basket in the space 34 provided, and carries away the bag containing the purchased goods.

No intervention from store operatives is needed, although if the customer requires the attendance of an operative, for whatever reason, she or he is able to summon one by interacting with the touch screen of the monitor 18, or else by activating alternative alarm means (not shown).

The self-service nature of the apparatus permits a customer wishing to purchase only a relatively few items in a hurry to do so without queueing at a conventional check-out. Being arranged as a unit, the customer can see and touch the display monitor, use the card reader and the scanner, and access the bag dispenser, as well as retrieving purchases from the basket, while standing at the same position. The display monitor is at eye level for an average customer, and the card reading payment device and the bar code scanning device are beneath the monitor.

Furthermore, the physical arrangement of the apparatus with the scanning device, display monitor, payment device, and bag dispensing station all located integrally in a vertical layout in an upright cabinet is very compact and takes up very little space in the store, and is thus ideally suited to smaller stores in which floor space is at a premium.

To provide an increased level of service, several units may be placed side-by-side so that they can be used simultaneously by several customers. In this arrangement the right-hand side of one unit forms a left-hand panel for an adjacent unit.

The electrical connections of the components are illustrated in Figure 6. A microprocessor controller 40 is connected to the bar code scanning device 16, the touch sensitive display monitor 18, and the card reading payment device 20 which incorporates the printer 38. More particularly, the bar code scanning device is coupled to an input of the controller 40 by a line 42 and continually monitors for bar codes. When it senses a bar code, it sends a corresponding signal to the controller over the line 42. The controller transmits information over a bi-directional line 44 to the display monitor 18 and indicates the product and its price. When all the customer's purchases have been scanned by the scanner 16, the customer puts their card into the card reader 20 which is connected to the controller 40 by a line 46. The entry of the card tells the controller that all purchases have been scanned and the controller verifies the card and notes the card details. The controller may operate off-line so far as the card is concerned or may be coupled by a telephone line 48 to a financial institution so that the card details and credit can be confirmed by the financial institution and the customer's account automatically debited. During this operation the controller sends display information to the display monitor 18 to which the customer can respond by using the touch-sensitive screen, for example to enter a

personal identification number (PIN). When the operation is completed the controller sends instructions to the printer over a line 50 to cause the printer to print a receipt and card voucher.

5 Various modifications may be apparent to the skilled reader which do not depart from the scope of the invention. For example an alternative form of customer interface than that described, such as a key-pad, may be provided on the apparatus. Also alternative payment-receiving apparatus may
10 be provided. If a cash dispensing unit is included, a customer may use their card to obtain cash in addition to their purchased goods. In another modification, the bag dispenser may be disposed to the side of the scanning device, instead of beneath it.

CLAIMS

1. Self service check-out apparatus for use by a customer at a store, the apparatus comprising scanning means (16) for scanning codes on goods to be purchased, display means (18) for displaying to the customer information concerning the scanned goods, payment receiving means (20) for receiving payment from the customer, and bag dispensing means (22) for dispensing carrier bags into which the customer may place the scanned goods; the scanning means, the display means, the payment receiving means, and the bag dispensing means being arranged as a unit.

2. Apparatus according to claim 1, in which the scanning means (16), display means (18), payment receiving means (20) and bag dispensing means (22) are all located integrally in an upright cabinet (12).

3. Apparatus according to claim 1, in which the scanning means comprises bar code scanning means (16) for scanning bar codes printed on goods to be purchased.

4. Apparatus according to claim 1, in which the display means comprises a display monitor (18) for displaying information such as may identify the product scanned and its price, and/or for identifying the various stages in the payment transaction.

5. Apparatus according to claim 1, further comprising interface means (18) permitting the customer to interact with the apparatus.

6. Apparatus according to claim 5, in which interface means comprises a touch-sensitive screen (18) on the display means.

7. Apparatus according to claim 1, in which the payment receiving means comprises a magnetic card or smart card reader apparatus (20), for allowing the customer to make payment for purchased goods.
- 5 8. Apparatus according to claim 1, further comprising means for dispensing a printed receipt.
9. Apparatus according to claim 1, further comprising automated cash dispensing means for enabling a customer to obtain cash in addition to the purchased goods.
- 10 10. Apparatus according to claim 1, further comprising a shelf (28) for supporting a shopping basket in use.
11. Apparatus according to claim 1, further comprising a shelf (24) located beneath and/or adjacent the bag dispensing means (22) for supporting a bag as scanned goods
15 are placed in the bag.
12. Apparatus according to claim 1, in which the scanning means (16), the payment receiving means (20), and the display means (18) are located on a substantially upright surface (14) of a cabinet.
- 20 13. Apparatus according to claim 12, in which the scanning means (16), the payment receiving means (20) and the display means (18) are all located above one another on the same substantially upright surface, such that the display means is disposed approximately at eye level, for an average
25 standing customer, and the payment receiving means and the scanning means are disposed beneath the display means.
14. Apparatus according to claim 12, in which the cabinet comprises a first recess (26,34) for storing empty shopping baskets.

15. Apparatus according to claim 14, including a shelf (28) located in the first recess.
16. Apparatus according to claim 1, in which the bag dispensing means (22) is disposed beneath and/or to one side
5 of the scanning means (16).
17. Apparatus according to claim 1, in which the bag dispensing means (22) is located in a second recess (23).
18. Apparatus according to claim 17, in which the second
10 recess (23) is formed in a substantially upright surface (14).
19. Self-service check-out apparatus comprising a plurality of adjacent (12) for several customers to operate simultaneously, each cabinet including apparatus in accordance with claim 1.
- 15 20. Self service check-out apparatus substantially as herein described with reference to the accompanying drawings.



Application No: GB 9913214.4
Claims searched: 1-20

Examiner: Mike Davis
Date of search: 2 August 1999

**Patents Act 1977
Search Report under Section 17**

Databases searched:

UK Patent Office collections, including GB, EP, WO & US patent specifications, in:

UK CI (Ed.Q): G4H (HJ), A4L (LAAK)

Int CI (Ed.6): G06K, G07G, A47F

Other: Online: WPI, EPODOC, JAPIO

Documents considered to be relevant:

Category	Identity of document and relevant passage	Relevant to claims
X	US 5641039 (DUMONT) whole document	1-11,16-19
X	US 5437346 (DUMONT) whole document	1-11,16-19

X	Document indicating lack of novelty or inventive step	A	Document indicating technological background and/or state of the art.
Y	Document indicating lack of inventive step if combined with one or more other documents of same category.	P	Document published on or after the declared priority date but before the filing date of this invention.
&	Member of the same patent family	E	Patent document published on or after, but with priority date earlier than, the filing date of this application.