



- (51) International Patent Classification:
G01J 3/26 (2006.01) *G02B 5/28* (2006.01)
- (21) International Application Number:
PCT/US2018/034710
- (22) International Filing Date:
25 May 2018 (25.05.2018)
- (25) Filing Language:
English
- (26) Publication Language:
English
- (30) Priority Data:
62/511,504 26 May 2017 (26.05.2017) US
62/597,223 11 December 2017 (11.12.2017) US

SC, SD, SE, SG, SK, SL, SM, ST, SV, SY, TH, TJ, TM, TN, TR, TT, TZ, UA, UG, US, UZ, VC, VN, ZA, ZM, ZW.

- (84) Designated States (*unless otherwise indicated, for every kind of regional protection available*): ARIPO (BW, GH, GM, KE, LR, LS, MW, MZ, NA, RW, SD, SL, ST, SZ, TZ, UG, ZM, ZW), Eurasian (AM, AZ, BY, KG, KZ, RU, TJ, TM), European (AL, AT, BE, BG, CH, CY, CZ, DE, DK, EE, ES, FI, FR, GB, GR, HR, HU, IE, IS, IT, LT, LU, LV, MC, MK, MT, NL, NO, PL, PT, RO, RS, SE, SI, SK, SM, TR), OAPI (BF, BJ, CF, CG, CI, CM, GA, GN, GQ, GW, KM, ML, MR, NE, SN, TD, TG).

Published:
— with international search report (Art. 21(3))

- (71) Applicant: CALIFORNIA INSTITUTE OF TECHNOLOGY [US/US]; 1200 E. California Blvd, MC 6-32, Pasadena, CA 91125 (US).
- (72) Inventors: SCHERER, Axel; 1661 North Road, Barnard, VT 05031 (US). JEON, Taeyoon; c/o California Institute of Technology, 1200 E California Blvd., M/c 6-32, Pasadena, CA 91125 (US).
- (74) Agent: WALKER, James, A.; Kaplan Breyer Schwarz, LLP, 100 Matawan Road, Suite 120, Matawan, NJ 07747 (US).
- (81) Designated States (*unless otherwise indicated, for every kind of national protection available*): AE, AG, AL, AM, AO, AT, AU, AZ, BA, BB, BG, BH, BN, BR, BW, BY, BZ, CA, CH, CL, CN, CO, CR, CU, CZ, DE, DJ, DK, DM, DO, DZ, EC, EE, EG, ES, FI, GB, GD, GE, GH, GM, GT, HN, HR, HU, ID, IL, IN, IR, IS, JO, JP, KE, KG, KH, KN, KP, KR, KW, KZ, LA, LC, LK, LR, LS, LU, LY, MA, MD, ME, MG, MK, MN, MW, MX, MY, MZ, NA, NG, NI, NO, NZ, OM, PA, PE, PG, PH, PL, PT, QA, RO, RS, RU, RW, SA,

(54) Title: SPECTRAL FILTER HAVING CONTROLLABLE SPECTRAL BANDWIDTH AND RESOLUTION

FIG. 8

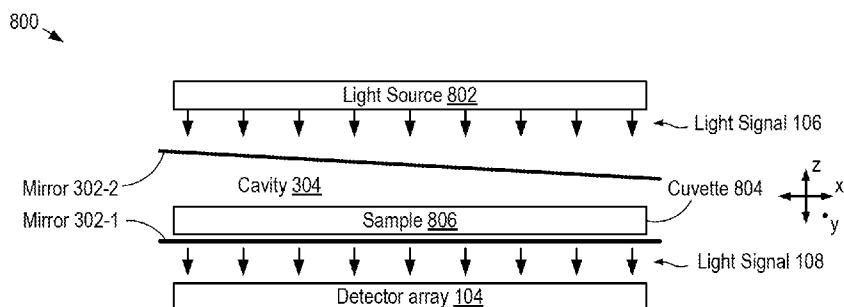

(57) Abstract: A Fabry-Perot cavity-based spectral notch filter is disclosed, where the filter is operative for providing an output optical signal whose spectral content is spatially dispersed along at least one direction, while also controlling the spectral position and spectral range of the output light. In some embodiments, the spectral filter is integrated with a detector arrays to realize a compact, high-resolution spectrometer that can rapidly acquire the absorption spectrum of a sample with high sensitivity.



Spectral Filter Having Controllable Spectral Bandwidth and Resolution

Related Applications

[0001] This application claims the benefit of U.S. Provisional Application No. 62/511,504 filed May 26, 2017 (Attorney Docket: CIT-7790-P) and U.S. Provisional Application No. 62/597,223, filed December 11, 2017 (Attorney Docket: CIT-7790-P2), each of which is incorporated herein by reference.

Field of the Invention

[0002] The present invention relates to spectral filters and, more particularly, to tunable spectral filters suitable for use in hyperspectral detectors and imaging systems.

Background of the Invention

[0003] Spectral "notch" filters are optical devices operative for receiving a light signal characterized by a relatively wide spectral range and selectively passing only a relatively narrower range of wavelengths within the light signal. In other words, wavelengths outside of a "transmission window" of the notch filter are reflected or blocked in some manner, while wavelengths within the transmission window are transmitted through the device.

[0004] Of particular interest are tunable spectral filters, in which the center wavelength of the transmission window can be tuned over a spectral range. The tunability of such devices enables simplification of many optical systems and introduces the opportunity to tune complete optical systems. When a tunable spectral filter is operatively coupled with a broadband light source, for example, a narrow linewidth, wavelength-agile source can be realized. In similar fashion, a highly wavelength-selective detector results from the combination of a tunable spectral filter and a broadband detector. Tunable spectral filters have found widespread use in diverse applications, such as telecommunications, medical diagnostics (*e.g.*, spectroscopy, optical coherence tomography (OCT), *etc.*), fluorescence microscopy, spectral or hyperspectral imaging, and environmental sensing, among others.

[0005] While tunable spectral filters have been developed based on a variety of different optical devices, such as liquid-crystal elements, fiber Bragg gratings, acousto-optic modulators, and surface-acoustic-wave (SAW) devices, perhaps the most commonly used is the tunable Fabry-Perot (FP) cavity.

[0006] A conventional tunable FP cavity includes a pair of parallel high-reflectivity mirrors that are closely spaced to give rise to an optically resonant cavity between them. The separation between the mirrors, referred to as the cavity length of the FP cavity, dictates what wavelengths pass through the cavity and what wavelengths are reflected by the cavity. Light having wavelength, λ , will resonate back and forth between the mirrors inside the optically resonant cavity when its cavity length, L , is equal to an integer number, N , of half-wavelengths (*i.e.*, when $L=N\lambda/2$) and be transmitted through the cavity with low loss. At the same time, light characterized by other wavelengths will be reflected by the FP cavity. By changing the cavity length, therefore, the wavelength of light passed by the cavity can be adjusted.

[0007] Unfortunately, prior-art tunable spectral filters are often slow, have limited tuning range, cannot operate across a wide range of wavelengths, have poor spectral resolution, and/or are complex to implement in many optical systems.

Summary

[0008] The teachings of the present disclosure enable optical systems having high spectral resolution over wide spectral ranges without some of the costs and disadvantages of the prior art. Systems in accordance with the present disclosure include Fabry-Perot cavity-based tunable filters that provide an optical output whose spectral content is spatially dispersed along at least one direction. Embodiments of the present invention are particularly well suited for use in hyperspectral imaging systems, hyperspectral detection systems, and high-resolution spectrometers.

[0009] Like the prior art, the present disclosure teaches a Fabry-Perot (FP) cavity comprising first and second planar mirrors that are highly reflective for a first light signal and form a high-finesse optically resonant cavity, where the separation between the mirrors (*i.e.*, the cavity length of the FP cavity) is controllable. As a result, the FP cavity can function as a spectral notch filter having a very narrow transmission window that can be spectrally tuned over a wide wavelength range.

[0010] In marked contrast to the prior art, embodiments in accordance with the present disclosure include one planar mirror that can be tilted relative to the other planar mirror along at least a first direction to realize a cavity length having a linear gradient along that direction. At each point along the first direction, therefore, the FP cavity has a different cavity length and passes a different wavelength at that point.

[0011] By controlling the magnitude of the angle between the mirrors, the range of wavelengths transmitted over the width of the FP cavity is controlled. This enables control over the spectral resolution along the line. In some embodiments, the separation between the mirrors is also controlled, enabling control over both the absolute wavelengths and spectral range of the light passed through the FP cavity.

[0012] An illustrative embodiment of the present invention is a hyperspectral detection system that includes a spectral filter and a linear detector array. The spectral filter has a dispersive operation state in which it is operative for receiving a broadband optical signal and providing an output optical signal to the detector array, where the spectral content of the output optical signal is distributed along a line from a first side of the spectral filter to a second side of the spectral filter (*i.e.*, along its width), and where the line is aligned with the elements of the detector array. As a result, each detector of the array receives a different wavelength signal in the spectral range of the output signal of the spectral filter.

[0013] The spectral filter is a tunable FP filter that includes a first planar mirror and a second planar mirror, each of which is highly reflective for an input light signal characterized by a first spectral range. The first and second mirrors define an optically resonant cavity having a uniform cavity length when the spectral filter is in its quiescent state.

[0014] The spectral filter also includes first and second vertical actuators that are operatively coupled to the first and second sides of the second mirror, respectively. Each vertical actuator controls the separation between the mirrors at its respective side of the cavity. As a result, the vertical actuators cooperatively control both the tilt of the second mirror, relative to the first mirror, as well as the vertical separation between the tilted second mirror and the first mirror.

[0015] In some embodiments, only the tilt of the second mirror is controlled and only one vertical actuator is necessary. In some embodiments, a rotary actuator (*e.g.*, a rotary comb-drive actuator) is operatively coupled with the second mirror to control its tilt relative to the first mirror. In some of these embodiments, a vertical actuator controls the vertical position of the tilted second mirror as a whole.

[0016] In some embodiments, the tilt of the second mirror is controllable along a second direction that is orthogonal to the first direction, such as the depth of the optically

resonant cavity. As a result, the spectral content of the output optical signal is distributed over a two-dimensional region.

[0017] An embodiment of the present invention is an apparatus comprising a spectral filter that is operative for receiving a first light signal characterized by a first spectral range and providing a second light signal that is spectrally dispersed along a first direction, wherein the second light signal is characterized by a second spectral range within the first spectral range, and wherein the spectral filter includes: a first mirror that is planar and partially transmissive for the first light signal; a second mirror that is planar and partially transmissive for the first light signal, wherein the first mirror and second mirror define an optically resonant cavity having a cavity length that is controllable along the first direction; and a first actuator that is configured to control a first separation between the first mirror and second mirror at a first location, wherein a first angle of the first mirror relative to the second mirror along the first direction is based on the first separation; wherein the second spectral range has a first spectral width that is based on the first angle.

[0018] Another embodiment of the present invention is an apparatus comprising a spectral filter that is operative for receiving a first light signal characterized by a first spectral range and providing a second light signal that is spectrally dispersed along a first direction, wherein the second light signal is characterized by a second spectral range within the first spectral range, and wherein the spectral filter includes: a first mirror that is planar and partially reflective for the first light signal; a second mirror that is planar and partially reflective for the first light signal, wherein the second mirror is moveable with respect to the first mirror, and wherein the second mirror is parallel with the first mirror when the spectral filter is in its quiescent state; and a first actuator that is configured to control a first angle between the first mirror and the second mirror along a first direction, wherein the second spectral range has a first spectral width that is based on the first angle.

[0019] Yet another embodiment of the present invention is a method comprising: (1) receiving a first light signal at a spectral filter that is characterized by a first spectral range, wherein the spectral filter includes: (i) a first mirror that is planar and partially transmissive for the first light signal; and (ii) a second mirror that is planar and partially transmissive for the first light signal, wherein the second mirror has a first angle relative to the first mirror along a first direction, and wherein the first angle is controllable; wherein the first and second mirror define an optically resonant cavity having a cavity length that is a first linear function of position along the first direction; (2) controlling the first angle such that it has a

first magnitude; and (3) providing a second light signal from the spectral filter such that it is spectrally dispersed along the first direction, the second light signal being characterized by a second spectral range that is within the first spectral range, the second spectral range having a first spectral width that is based on the first magnitude.

Brief Description of the Drawings

[0020] **FIG. 1** depicts a schematic drawing of a hyperspectral detection system in accordance with an illustrative embodiment of the present invention.

[0021] **FIGS. 2A-B** depict schematic drawings of cross-sectional views of an FP-cavity-based spectral filter in accordance with the prior art in different modes of operation.

[0022] **FIGS. 3A-C** depict schematic drawings of cross-sectional views of an FP-cavity-based spectral filter in accordance with the present disclosure in different exemplary modes of operation.

[0023] **FIGS. 4A-B** depict schematic drawings of top and sectional views of a spectral filter in accordance with the illustrative embodiment.

[0024] **FIGS. 5A-C** depict schematic drawings of cross-sectional views of spectral filter **102** at different stages of its fabrication in accordance with the illustrative embodiment.

[0025] **FIG. 6** depicts operation of a first exemplary method for determining the spectral content of a light signal in accordance with the present invention.

[0026] **FIG. 7** depicts operation of a second exemplary method for determining the spectral content of a light signal in accordance with the present invention.

[0027] **FIG. 8** depicts a schematic drawing of a cross-sectional view of a high-resolution spectrometer in accordance with the present disclosure.

Detailed Description

[0028] **FIG. 1** depicts a schematic drawing of a hyperspectral detection system in accordance with an illustrative embodiment in accordance with the present disclosure. System **100** includes spectral filter **102**, detector array **104**, and processor **114**.

[0029] Spectral filter **102** is an FP-cavity-based spectral filter that is configured to receive input optical signal **106** and provide output optical signal **108**, wherein input optical

signal **106** propagates along axis **A1** and is characterized by a first spectral range having width **w1**, and wherein output optical signal **108** is characterized by second spectral range having width **w2**, and further wherein the first spectral range includes the second spectral range. Furthermore, spectral filter **102** provides output optical signal **108** such that its spectral content is spatially dispersed along the x-direction, thereby imparting a spatial correlation on the spectral content of the output optical signal. Spectral filter **102** is characterized by longitudinal axis **A2**, which forms angle α with axis **A1**. In the depicted example, α is equal to 90° (*i.e.*, light signal propagates along a direction that is normal to spectral filter **102**).

[0030] Detector array **104** is a linear array of conventional detectors operative for detecting any wavelength included in input optical signal **106**. Detector array **104** includes detectors **110-1** through **110-m** (referred to, collectively, as detectors **110**) which provide output signals **112-1** through **112-m** (referred to, collectively, as output signals **112**), respectively, to processor **114**, where the magnitude of each output signal is based on the intensity of the light incident on its respective detector.

[0031] Processor **114** is a conventional processor comprising circuitry operative for receiving output signals **112-1** through **112-m**, providing control signals to spectral filter **102**, executing instructions, storing and retrieving data, and estimating spectral information, among other things.

[0032] Spectral filter **102** and detector array **104** are arranged such detectors **110** are aligned with the x-direction such that each of detectors **110** receives a different wavelength signal included in output optical signal **108**. For the purposes of this Specification, including the appended claims, the term wavelength signal is defined as light signal whose spectral content is characterized by a center wavelength and a narrow spectral range that surrounds it.

[0033] In the depicted example, input optical signal is a broadband light signal that has a spectral content that spans the complete mid-infrared (MIR) spectral range and includes wavelength signals λ_1 through λ_n . For the purposes of this Specification, including the appended claims, the MIR spectral range is defined as the wavelength range from 2 microns to 20 microns.

[0034] In operation, spectral filter **102** filters the spectral content of input optical signal **106** and provides output optical signal **108** such that it has a spectral range that is at

least a portion of the spectral range of input optical signal **106**. In other words, output optical signal **108** is characterized by spectral content that includes wavelength signals λa through λb , where $a \geq 1$ and $b \leq n$, such that the wavelength signals are dispersed along the x-direction. As discussed below, spectral filter **102** is tunable such that it can control what portion of the spectral range of input optical signal is included in its output optical signal, as well as the spectral width of the output optical signal (*i.e.*, the spectral range from λa to λb).

[0035] It should be noted, while the illustrative embodiment is configured for operation across the MIR spectral range, embodiments in accordance with the present disclosure can be configured to operate over virtually any wavelength range without departing from the scope of the present disclosure.

[0036] **FIGS. 2A-B** depict schematic drawings of cross-sectional views of an FP-cavity-based spectral filter in accordance with the prior art in different modes of operation.

[0037] Spectral filter **200** is a conventional FP-cavity-based device that includes parallel mirrors **202-1** and **202-2**, which define optically resonant cavity **204** having a cavity length equal to the separation between the mirrors. The parallel nature of its mirrors enables spectral filter **200** to receive a multispectral input optical signal having a wide spectral range and pass an output optical signal containing only one narrow wavelength signal, where the spectral content of the output optical signal is uniform across the entire width of optically resonant cavity **204**. By controlling the position of mirror **202-2** relative to mirror **202-1**, the cavity length of spectral filter **200** is controlled, thereby enabling the wavelength signal passed by the spectral filter to be tuned over a desired tuning range.

[0038] In a first operational mode of spectral filter **200**, depicted in FIG. 2A, mirrors **202-1** and **202-2** are parallel and separated by cavity length **L** across the width of optically resonant cavity **204** from first location **x1** to second location **x2**. In this configuration, the spectral filter receives input optical signal **206**, which includes the spectral range from λA to λB . Based on its cavity length of **L**, spectral filter **200** passes only wavelength signal λa within the spectral range of λA to λB .

[0039] In a second operational mode of spectral filter **200**, depicted in FIG. 2B, the position of mirrors **202-1** is changed by distance $\Delta 1$ such that mirrors **202-1** and **202-2** are still parallel but separated by new cavity length **L'** across the width of optically resonant cavity **204** from first location **x1** to second location **x2**. In this new configuration, the

spectral filter passes only wavelength signal λ_b within the spectral range of λ_A to λ_B over the width of the optically resonant cavity.

[0040] In sharp contrast to the prior art, embodiments in accordance with the present disclosure control the angle of one of the mirrors of an FP cavity-based spectral filter relative to the plane of the other mirror of the cavity, thereby adding spectral dispersive capability to the device. By controlling both a tilt of one mirror as well as the separation between the two mirrors, the position and width of the spectral range passed by the spectral filter can be controlled, providing significant advantage over prior-art spectral filters.

[0041] **FIGS. 3A-C** depict schematic drawings of cross-sectional views of an FP-cavity-based spectral filter in accordance with the present disclosure in different exemplary modes of operation.

[0042] Spectral filter **102** includes planar mirrors **302-1** and **302-2**, which define optically resonant cavity **304** (hereinafter referred to as "cavity **304**") whose cavity length is **L1** when the spectral filter is in its quiescent state. As discussed in more detail below, mirror **302-2** is operatively coupled with a pair of vertical actuators, one of which is operative for controlling the height of first end **306** of mirror **302-2** at location **x1**, and the other of which is operative for controlling the height of second end **308** of mirror **302-2** at location **x2**. As a result, the angle of mirror **302-2** relative to mirror **302-1** can be controlled to realize a cavity length having a linear gradient, **L(x)**, along the width of cavity **304**. Furthermore, since the position of each of ends **306** and **308** is controlled, by adjusting both actuators, the separation between tilted mirror **302-2** and stationary mirror **302-1** can be controlled.

[0043] FIG. 3A depicts spectral filter **102** in a first configuration wherein second end **308** has been moved toward mirror **302-1** by a distance $\Delta 2$ while first end **306** remains in its quiescent position. As a result, mirror **302-2** is tilted at angle θ relative to mirror **302-1**. Since first end **306** remains in its original position, the cavity length at location **x1** remains **L1**, while the cavity length at location **x2** is reduced to **L2**.

[0044] Since the separation between mirrors **302-1** and **302-2** is non-uniform along the width of cavity **304**, the separation between them at location **x1** is designated herein as spacing **s**. It will be appreciated by one skilled in the art that any point along cavity **304**

(e.g., the separation at location **x2**, the spacing in the center of cavity **304**, etc.) can be used as a reference for this spacing, however.

[0045] Due to its cavity length of **L1** at **x1**, cavity **304** passes wavelength signal λ_c of light signal **106** at location **x1**. In similar fashion, due to its cavity length of **L2** at **x2**, the wavelength signal of light signal **106** passed by cavity **304** reduces to λ_d at location **x2**. From **x1** to **x2**, cavity **304** passes a set of wavelength signals whose wavelengths decrease linearly from λ_c to λ_d according to cavity length **L(x)**.

[0046] FIG. 3B depicts spectral filter **102** in a second configuration wherein second end **308** has been moved toward mirror **302-1** by twice the distance as that shown in FIG. 3A (i.e., by $2\Delta 2$), while first end **306** remains in its quiescent position. As a result, mirror **302-2** is tilted at angle 2θ relative to mirror **302-1**. Since first end **306** remains in its original position, the cavity length at location **x1** remains **L1**, while the cavity length at location **x2** is decreased to **L2'**. As a result, in the second configuration, cavity **304** passes wavelength signals within the range of λ_c to λ_e , which are spatially dispersed along the line from location **x1** to location **x2**.

[0047] It should be noted that, since the change in cavity length across the width of cavity **304** in the second configuration is twice the magnitude of the change in cavity length in the first configuration, the spectral range passed in the second configuration is twice as wide as the spectral range passed in the first configuration. As a result, the spectral resolution attainable in the first configuration is twice the spectral resolution in the second configuration.

[0048] FIG. 3C depicts spectral filter **102** in a third configuration wherein second end **308** has been moved to effect a tilt of θ on mirror **302-1** while also reducing the separation of the mirrors by distance $\Delta 2$). As a result, the cavity length at location **x1** is **L2**, while the cavity length at location **x2** is **L2'**. As a result, in the third configuration, cavity **304** passes wavelength signals within the range of λ_d to λ_e , which are spatially dispersed along the line from location **x1** to location **x2**.

[0049] As evinced by FIGS. 3A-C, embodiments in accordance with the present disclosure can control either or both of the spectral range and spectral resolution of optical output signal **108** over a wide range (subject to the limitations of the actuators used). It should be noted that, by sequentially implementing the first and third configurations described above, the spectral range obtained for light signal **108** via the second

configuration can be obtained – but with twice the resolution. Furthermore, by setting the tilt angle of mirror **302-2** to realize a high-spectral resolution output over a narrow spectral range and changing the separation between mirrors **302-1** and **302-2** N times, N high-resolution sub-spectra within the spectral range of input light signal **106** can be obtained. In fact, in some embodiments, the entire spectral range of input light signal **106** can be scanned with high-resolution in such a manner by judicious selection of the tilt angle, the width of each spectral sub-range, and the value of N.

[0050] The structure of mirrors **302-1** and **302-2** (referred to, collectively, as mirrors **302**) can take many forms, including first surface reflectors, Bragg reflectors, and the like, without departing from the scope of the present disclosure. Typically, the structure of mirrors **302** is dictated by the wavelength of light over which spectral filter **102** is intended to operate. For operation in the MIR spectral range, for example, it can be advantageous to employ mirrors that are Bragg reflectors comprising a plurality of high-refractive-index structural material that are separated by air gaps.

[0051] **FIGS. 4A-B** depict schematic drawings of top and sectional views of a spectral filter in accordance with the illustrative embodiment. Spectral filter **102** includes cavity **304**, actuators **402-1** and **402-2**, tethers **404**, and anchors **406**. The sectional view shown in FIG. 4B is taken through line a-a depicted in FIG. 4A.

[0052] As discussed above, cavity **304** includes mirrors **302-1** and **302-2**, each of which is highly reflective for input optical signal **106**.

[0053] Mirror **302-1** is a stationary Bragg reflector disposed on the surface of substrate **408**. In the depicted example, substrate **408** is a conventional silicon substrate; however, a wide variety of materials can be used in substrate **408** without departing from the scope of the present invention.

[0054] Mirror **302-2** is suspended above mirror **302-1** via tethers **404**, which extend between each of actuators **402-1** and **402-2** and anchors **406**.

[0055] In the depicted example, each of mirrors **302** is a multilayer Bragg reflector designed to realize high-reflectivity (> 99.9999%) over the entire MIR spectral range. Each of mirrors **302** includes a plurality of structural layers **410** having a relatively higher refractive index and a plurality of air layers that function as relatively lower-refractive index layers in the Bragg reflector structure. The structural layers and air layers alternate such that adjacent structural layers are separated by an air layer. In the depicted example, each

mirror includes three structural layers made of low-residual-stress amorphous silicon having a refractive index of approximately 3.5 and a thickness of approximately 785 nm (approximately $\frac{1}{4}$ of the center wavelength of the MIR spectral range as measured in the material of the structural layer). Adjacent structural layers are separated by an air gap having a thickness of approximately 2.75 microns (approximately $\frac{1}{4}$ of the center wavelength of the MIR spectral range in air). It should be noted that the materials and design parameters provided for mirrors **302** are merely exemplary and that myriad alternative designs for the mirrors of spectral filter **102** are within the scope of the present disclosure.

[0056] Each of actuators **402-1** and **402-2** (referred to, collectively, as actuators **402**) is a vertical electrostatic actuator that includes a fixed electrode disposed on substrate **408** and a movable electrode that is affixed to mirror **302-2**. Specifically, actuator **402-1** includes fixed electrode **412-1** and movable electrode **414-1**, while actuator **402-2** includes fixed electrode **412-2** and moveable electrode **414-2**.

[0057] Actuator **402-1** controls the cavity length at location **x1** based on a voltage applied between electrodes **412-1** and **414-1**. In similar fashion, actuator **402-2** controls the cavity length at location **x2** based on a voltage applied between electrodes **412-1** and **414-1**. In the depicted example, an applied voltage of approximately 10 V is sufficient to fully actuate each of actuators **402-1** and **402-2**.

[0058] Electrodes **412-1** and **412-2** are regions of doped amorphous silicon that are electrically connected with substrate **408**, which is connected to electrical ground. In some embodiments, electrodes **412-1** and **412-2** are electrically isolated from the substrate by layer of dielectric, such as silicon nitride, to enable them to be independently driven.

[0059] Electrodes **414-1** and **414-2** are regions of doped amorphous silicon that are disposed on the bottom surface of mirror **302-2**. Electrodes **414-1** and **414-2** are electrically connected to bond pads **418-1** and **418-2**, respectively, via electrical traces of doped amorphous silicon that run along the underside of tethers **404**.

[0060] Tethers **404** are beams of amorphous silicon having a cross-sectional shape that substantially selectively enables flexure of the tethers out of the x-y plane, while substantially inhibiting their flexure within the x-y plane. It should be noted that, while the depicted example includes tethers that are simple straight beams, myriad tether designs can be used in spectral filter **102** without departing from the scope of the present invention.

Tethers suitable for use in spectral filter **102** include, without limitation, serpentine springs, folded-beam tethers, and the like. It should be further noted that the actuation voltage required to configure spectral filter **102** is significantly affected by the design of tethers **404**.

[0061] Anchors **406** are stationary, mechanically robust projections that extend vertically from the top surface of substrate **408**.

[0062] Bond pads **418-1** and **418-2** are formed on the top of their respective anchors **406** by opening a window to the material of tethers **404** and depositing metal into the openings (typically via a shadow-mask process).

[0063] Each of electrodes **414-1** and **414-2**, as well as their respective traces is electrically isolated from the structural material of mirror **302-2** via a thin layer of dielectric **416** so that each of electrodes **414-1** and **414-2** can be individually addressed. In the depicted example, dielectric **416** is silicon nitride, which is substantially unaffected by the etchant used to release mirror **302-2** from substrate **408**, as discussed below.

[0064] It should be noted that actuators **402-1** and **402-2**, and their arrangement in spectral filter **102**, represents merely one example of a suitable actuation scheme for the spectral filter. Suitable alternative actuation includes vertical comb-drive actuators (which could be disposed on either sides of mirror **302-2**, or elsewhere), rotary comb-drive actuators (disposed at the center of the top and bottom edges, or disposed at either side, of mirror **302-2**), thermal actuators, magnetostrictive actuators, non-micromechanical actuators, and the like.

[0065] While the depicted example is a spectral filter that spatially disperses the spectral content of its output optical signal along one dimension, alternative embodiments within the scope of the present disclosure include spectral filters that disperse the spectral content of their output optical signals along two lateral directions, such as the x- and y-directions. To realize such a spectral filter, one or more additional actuators arranged along the y-direction can be used. Alternatively, two-axis gimbal structures, such as those used for two-axis beam-steering mirrors known in the prior art, can be employed to provide two-dimensional orientation control of mirror **302-2**.

[0066] **FIGS. 5A-C** depict schematic drawings of cross-sectional views of spectral filter **102** at different stages of its fabrication in accordance with the illustrative

embodiment. The method described herein employs conventional surface micromachining processes developed within the Micro Electro Mechanical Systems (MEMS) technology realm.

[0067] The fabrication of spectral filter **102** begins with formation of a layer of doped, low-residual stress amorphous silicon on the top surface of substrate **408**. This layer is then patterned to define the first structural layer **410** in mirror **302-1**, as well as electrodes **412-1** and **412-2**.

[0068] Successive deposition and patterning of sacrificial layers **502** and structural layers **410** is then performed. In the depicted example, sacrificial layers **502** comprise borophosphosilicate glass (BPSG) and structural layers **410** comprise doped, low-residual stress amorphous silicon. The layer structure of sacrificial and structural layers defines the nascent Bragg reflector stack of mirror **302-1**.

[0069] Sacrificial layer **504** is then formed over the entire surface of the substrate to encase mirror **302-1** and electrodes **412-1** and **412-2** in sacrificial material.

[0070] FIG. 5A depicts a cross-sectional view of nascent spectral filter **102** after formation of sacrificial layer **504**.

[0071] Sacrificial layer **504** is then patterned to define pedestals **508**, which function as the core of anchors **406**.

[0072] The first (bottom-most) structural layer **410** of mirror **302-2** is then formed on surface **506** and over pedestals **508**. This structural layer is then patterned to define the bottom-most layer of mirror **302-2**, electrodes **414-1** and **414-2** and their respective traces, and outer shell **510** of anchors **406**.

[0073] FIG. 5B depicts a cross-sectional view of an anchor **406** after formation of the first structural layer **410** of mirror **302-2**.

[0074] Successive deposition and patterning of sacrificial layers **502** and structural layers **410** is then performed again to complete the nascent Bragg reflector stack of mirror **302-2**, as well as tethers **406**.

[0075] FIG. 5C depicts a cross-sectional view of nascent spectral filter **102** after formation of the layer structure of mirror **302-2**.

[0076] The nascent structure of spectral filter **102** is then completed by forming vias to expose the top surface of shell **510** for the anchors that are electrically connected to electrodes **414-1** and **414-2**.

[0077] To release mirror **302-2** and tethers **406** from substrate **408**, thereby making them mechanically active, nascent filter **102** is subjected to a release etch in hydrofluoric acid to remove all regions of sacrificial material **502** except for pedestals **508**, which are protected from attack by shells **510**.

[0078] After the release etch, metal is deposited using a shadow-mask deposition to form bond pads **418-1** and **418-2**.

[0079] It should be noted that the materials and structure of spectral filter **502** are merely exemplary and that many suitable combinations of structural and sacrificial materials can be used without departing from the scope of the present invention.

[0080] Furthermore, many alternative methods for forming spectral filter **102** exist within the scope of the present disclosure. Other exemplary methods include fabrication of each mirror structure on separate substrates and then joining the substrates to form an FP cavity. In some embodiments, separate substrates comprising the mirrors are joined using a resilient material (*e.g.*, Polydimethylsilicone (PDMS), *etc.*) that enables the use of mechanical force (*e.g.*, clamping, pneumatic or hydraulic actuation, screws, *etc.*) to compress one or both sides of an FP cavity to induce a desired tilt and/or mirror separation.

[0081] Furthermore, in some fabrication methods suitable for forming spectral filter **102**, an air-layer-based Bragg reflector is formed by etching an arrangement of holes through the structural-material layers and sacrificial-material layers of at least one of nascent mirrors **302**. Once the holes are formed through the layer stack, a timed sacrificial etch is used to laterally etch most, but not all, of the sacrificial material layers. As a result, when the timed etch is finished, small regions of sacrificial material remain, which function to hold the structural-material layers in their desired spatial relationship.

[0082] As described above, the cavity length at both ends of cavity **304** can be controlled; therefore, each of the shortest and longest wavelengths in the spectral content of output optical signal **106** can be independently controlled. This affords spectral measurement methods are not practical, or in some cases, possible, using prior art hyperspectral measurement systems. Two examples of spectral measurement methods in accordance with the present disclosure are described here.

[0083] **FIG. 6** depicts operation of a first exemplary method for determining the spectral content of a light signal in accordance with the present invention. Method **600** is described herein with continuing reference to FIGS. 1, 3, and 4. Method **600** begins with operation **601**, wherein input optical signal **106** is received by hyperspectral detection system **100**.

[0084] As noted above, in the depicted example, input optical signal **106** spans the wavelength range from 2 microns to 20 microns. For the purposes of the exemplary methods described here, the quiescent cavity length of cavity **304** passes light whose wavelength is equal to 20 microns and detector array **104** includes 1000 detectors **110**, which are equally spaced along the x-direction.

[0085] At operation **602**, mirror **302-2** is tilted by angle θ_1 without changing the separation of mirrors **302** at location **x1**. The magnitude of θ_1 is selected such that the spectral width of output optical signal **108** is 1 micron. As a result, output optical signal **108** has a spectrum that spans the wavelength range from 20.0 microns to 19.001 microns.

[0086] For each of $i=1$ through M , wherein M is the number of sub-spectra of light signal **106** to be measured ($M=18$ in the present example):

[0087] At operation **603**, spacing $s-i$ is established to set the spectral position of the spectrum of output optical signal **108-i**. Each time the value of i is indexed, the value of $s-i$ is changed by an amount suitable to change the spectral position of the spectrum of output optical signal **108-i** by W/M , while maintaining the tilt angle of mirror **302-2** at θ_1 . In the depicted example, therefore, at operation **606**, the spectrum of output signal **108** shifts to shorter wavelengths by one micron while maintaining the same spectral width.

[0088] At operation **604**, output optical signal **108-i** is provided to detector array **104**. As a result, detectors **110** detect wavelength signals that span the range from 20.0 microns to 19.001 microns with a spectral resolution of 1 nm.

[0089] At operation **605**, output signals **112-i** are provided to processor **114**.

[0090] For each value of i operations **603** through **605** are repeated.

[0091] At operation **606**, processor **114** determines the spectral content of input optical signal **106** based on output signals **112-1** through **112-M**.

[0092] **FIG. 7** depicts operation of a second exemplary method for determining the spectral content of a light signal in accordance with the present invention. Method **700** is

described herein with continuing reference to FIGS. 1, 3, and 4. Method **700** enables a wide spectral range of light to be quickly measured at low resolution to identify spectral regions within it that warrant measurement at higher resolution. Method **700**, therefore, provides a “spectral zoom” capability that enables a user to quickly identify and analyze only those portions of the larger spectrum signal that are deemed critical.

[**0093**] Method **700** begins with operation **701**, wherein a complete spectrum of interest within input optical signal **106** is passed by spectral filter **102** as output optical signal **108**. In the depicted example, the spectrum of interest is the entire MIR spectral range. To pass the entire spectrum of interest, a first, typically large, tilt angle, θ_2 is established for mirror **302-2**.

[**0094**] At operation **702**, processor **114** identifies N high-interest sub-spectral regions, HSS-1 through HSS- N , within the spectrum of interest based on output signals **112** from detectors **110**.

[**0095**] At operation **703**, for each of $j=1$ through N , spacing $s-j$ and tilt angle $\theta-j$ are established such that the spectral content of output optical signal **106** is set to HSS- j .

[**0096**] At operation **704**, for each of $j=1$ through N , processor **114** determines the spectral content of HSS- j .

[**0097**] In some embodiments, the high-resolution measurement of at least one high-interest spectrum reveals one or more smaller spectral regions that warrant analysis with even higher spectral resolution. In such cases, for each of these smaller spectral regions, spacing s and tilt angle θ can be re-established such that output optical signal **108** distributes only its spectrum across detectors **110**. It should be noted that this spectral “zooming” process can be repeated until the practical limit on the control resolution of actuators **402-1** and **402-2** is reached.

[**0098**] In some embodiments, once a specific absorption peak of interest is identified (e.g., in operation **702**). The cavity length of cavity **304** is adjusted to transmit just the wavelength of this absorption peak across the width of the optically resonant cavity. As a result, each of detectors **110** senses the same wavelength, thereby converting system **100** into a spectral-imaging camera.

[**0099**] As discussed above, hyperspectral detection systems have found widespread use in many applications, such as hyperspectral imaging and spectroscopy. Embodiments

of the present invention are particularly well suited for use in high-resolution spectroscopy due to the ability to operate in the MIR spectral range.

[00100] **FIG. 8** depicts a schematic drawing of a cross-sectional view of a high-resolution spectrometer in accordance with the present disclosure. Spectrometer **800** includes spectral filter **102**, detector array **104**, light source **802**, and sample cuvette **804**.

[00101] Light source **802** is a radiation source operative for providing light signal **106**.

[00102] Sample cuvette **804** is a chamber suitable for holding a test sample **806**, which is typically a fluid such as blood, spittle, *etc.* In the depicted example, sample **806** is blood.

[00103] It should be noted that prior-art spectrometers – particularly compact spectrometers - often suffer from limited sensitivity because the material being analyzed does not absorb efficiently and the path length of light through the sample is not long enough. Longer path lengths limit miniaturization and complicate the optical filter response by allowing multiple wavelengths to resonate within the system.

[00104] The depicted example is afforded significant advantage over prior-art spectrometers, however, due to the fact that sample cuvette **804** is located in cavity **304** formed by mirrors **302-1** and **302-2**.

[00105] As a result, the absorption peaks in sample **806** are optically amplified and the geometry of system **800** enables the measurement and quantification of trace amounts of material within cavity **304**. It should be noted that the amplification of the light absorption by the quality factor, Q , of cavity **304**, which can easily exceed 2000, will enable the improvement of the sensitivity by this factor. Consequently, the contrast of the spectrum is markedly increased by locating sample **806** within the optical hyperspectral filtering cavity of spectral filter **102**.

[00106] In some embodiments, cavity **304** is oriented at a non-normal angle relative to the propagation direction of input optical signal **106** (*i.e.*, $\alpha \neq 90^\circ$) such that both of mirrors **302** are at a non-right angle to axis **A1** when the spectral filter is in its quiescent state. In such embodiments, the resonant peak position of cavity **304** is shifted according to the cosine of angle α and the spectral range of light transmitted through the cavity in its

quiescent state is narrowed. As a result, the quality factor, Q , of cavity **304** is improved, thereby markedly improving the sensitivity of spectrometer **800**.

[00107] It should be noted that, while this improvement is described here as it relates to spectrometer **800**, improvement in system performance arising due to orienting cavity **304** at a non-normal angle relative to the propagation direction of input optical signal **106** affords advantages in other embodiments in accordance with the present disclosure.

[00108] It should be noted that, while location of sample **806** in the optically resonant cavity is highly advantageous, the sample can also be located between light source **802** and spectral filter **102**, or between spectral filter **102** and detector array **104**, without departing from the scope of the present disclosure.

[00109] It is to be understood that the disclosure teaches just one example of the illustrative embodiment and that many variations of the invention can easily be devised by those skilled in the art after reading this disclosure and that the scope of the present invention is to be determined by the following claims.

What is claimed is:

1. An apparatus comprising a spectral filter that is operative for receiving a first light signal characterized by a first spectral range and providing a second light signal that is spectrally dispersed along a first direction, wherein the second light signal is characterized by a second spectral range within the first spectral range, and wherein the spectral filter includes:

a first mirror that is planar and partially transmissive for the first light signal;

a second mirror that is planar and partially transmissive for the first light signal, wherein the first mirror and second mirror define an optically resonant cavity having a cavity length that is controllable along the first direction; and

a first actuator that is configured to control a first separation between the first mirror and second mirror at a first location, wherein a first angle of the first mirror relative to the second mirror along the first direction is based on the first separation;

wherein the second spectral range has a first spectral width that is based on the first angle.

2. The apparatus of claim 1 wherein the spectral filter is operative for providing the second light signal such that it is also spectrally dispersed along a second direction that is orthogonal with the first direction, the second light signal being characterized by a third spectral range along the second direction, and wherein the spectral filter further includes a second actuator that is configured to control a second angle of the first mirror relative to the second mirror along the second direction, and further wherein the third spectral range has a second spectral width that is based on the second angle.

3. The apparatus of claim 1 further comprising a second actuator that is configured to control a second separation between the first mirror and second mirror at a second location, wherein the second separation defines one of the minimum wavelength and maximum wavelength of the second spectral range.

4. The apparatus of claim 1 wherein the second mirror is a Bragg mirror that comprises a plurality of layers of a first material, wherein each pair of adjacent layers of the plurality thereof is separated by an air gap.

5. The apparatus of claim 1 wherein the second spectral range includes at least a portion of the mid-infrared spectral range.

6. The apparatus of claim 1 further comprising a plurality of detectors that is configured to receive the second light signal from the spectral filter, wherein the spectral filter and plurality of detectors are arranged such that each detector of the plurality thereof receives a different wavelength signal of a plurality of wavelength signals that are characterized by different wavelengths within the second spectral range.

7. The apparatus of claim 6 further comprising:
a light source for providing the first light signal; and
a sample chamber for containing a sample;
wherein the light source, the spectral filter, and the sample chamber are dimensioned and arranged such that the plurality of detectors receives the plurality of wavelength signals after the plurality of wavelength signals have passed through the sample chamber.

8. The apparatus of claim 7 wherein the sample chamber is located between the first mirror and second mirror.

9. An apparatus comprising a spectral filter that is operative for receiving a first light signal characterized by a first spectral range and providing a second light signal that is spectrally dispersed along a first direction, wherein the second light signal is characterized by a second spectral range within the first spectral range, and wherein the spectral filter includes:

a first mirror that is planar and partially reflective for the first light signal;
a second mirror that is planar and partially reflective for the first light signal, wherein the second mirror is moveable with respect to the first mirror, and wherein the second mirror is parallel with the first mirror when the spectral filter is in its quiescent state; and
a first actuator that is configured to control a first angle between the first mirror and the second mirror along a first direction, wherein the second spectral range has a first spectral width that is based on the first angle.

10. The apparatus of claim 9 wherein the spectral filter further includes a second actuator that is configured to control one of the minimum wavelength and maximum wavelength of the second spectral range.

11. The apparatus of claim 10 wherein the first actuator is configured to control a first separation between the first mirror and second mirror at a first location, the first angle being based on the first separation, and wherein the second actuator is configured to control a second separation between the first mirror and second mirror at a second location, the one of the minimum wavelength and maximum wavelength of the second spectral range being based on the second separation.

12. The apparatus of claim 9 wherein the second mirror is a Bragg mirror that comprises a plurality of layers of a first material, wherein each pair of adjacent layers of the plurality thereof is separated by an air gap.

13. The apparatus of claim 9 wherein the second spectral range includes at least a portion of the mid-infrared spectral range.

14. The apparatus of claim 9 further comprising a plurality of detectors that is configured to receive the second light signal from the spectral filter, wherein the spectral filter and plurality of detectors are arranged such that each detector of the plurality thereof receives a different wavelength signal of a plurality of wavelength signals that are characterized by different wavelengths within the second spectral range.

15. The apparatus of claim 14 further comprising:
a light source for providing the first light signal; and
a sample chamber for containing a sample;
wherein the light source, the spectral filter, and the sample chamber are dimensioned and arranged such that the plurality of detectors receives the plurality of wavelength signals after the plurality of wavelength signals have passed through the sample chamber.

16. The apparatus of claim 15 wherein the sample chamber is located between the first mirror and second mirror.

17. The apparatus of claim 16 wherein the first light signal propagates along a second direction, and wherein each of the first mirror and second mirror is oriented at a second angle relative to the second direction when the spectral filter is in its quiescent state, and further wherein the second angle is not equal to 90°.

18. A method comprising:

(1) receiving a first light signal at a spectral filter that is characterized by a first spectral range, wherein the spectral filter includes:

(i) a first mirror that is planar and partially transmissive for the first light signal; and

(ii) a second mirror that is planar and partially transmissive for the first light signal, wherein the second mirror has a first angle relative to the first mirror along a first direction, and wherein the first angle is controllable;

wherein the first and second mirror define an optically resonant cavity having a cavity length that is a first linear function of position along the first direction;

(2) controlling the first angle such that it has a first magnitude; and

(3) providing a second light signal from the spectral filter such that it is spectrally dispersed along the first direction, the second light signal being characterized by a second spectral range that is within the first spectral range, the second spectral range having a first spectral width that is based on the first magnitude.

19. The method of claim 18 further comprising (4) controlling a first separation between the first and second mirrors at a first location such that the first separation has a second magnitude, wherein one of the maximum wavelength and minimum wavelength of the second spectral range is based on the second magnitude.

20. The method of claim 18 further comprising (4) providing the spectral filter such that at least one of the first mirror and second mirror is a Bragg mirror that includes a plurality of layers of a first material, wherein each pair of adjacent layers of the plurality thereof is separated by an air gap.

21. The method of claim 18 wherein the second spectral range includes at least a portion of the mid-infrared spectral range.

22. The method of claim 18 further comprising:

(4) receiving the second light signal at a plurality of detectors arranged along the first direction such that each detector of the plurality thereof receives a different wavelength signal of a first plurality of wavelength signals that are characterized by different wavelengths within the second spectral range; and

(5) providing a first plurality of output signals, wherein each output signal of the first plurality thereof is based on the magnitude of a different wavelength signal of the first plurality thereof.

23. The method of claim 22 further comprising:

(6) providing a sample such that it is located between a light source and the plurality of detectors, wherein the light source is operative for providing the first light signal, and wherein the second light signal is received at the plurality of detectors after the second light signal has passed through a sample; and

(7) determining a property of the sample based on the plurality of output signals.

24. The method of claim 23 wherein the sample is provided such that it is located between the first mirror and second mirror.

25. The method of claim 18 further comprising:

(4) controlling the first angle such that it has a second magnitude; and

(5) providing a third light signal from the spectral filter such that it is spectrally dispersed along the first direction, the third light signal being characterized by a third spectral range that is within the first spectral range, and the third spectral range having a second spectral width that is based on the second magnitude, wherein the first spectral width and second spectral width are different.

26. The method of claim 25 further comprising:

(6) receiving the second light signal at a plurality of detectors arranged along the first direction such that each detector of the plurality thereof receives a different wavelength signal of a first plurality of wavelength signals that are characterized by different wavelengths within the second spectral range;

(7) providing a first plurality of output signals, wherein each output signal of the first plurality thereof is based on the magnitude of a different wavelength signal of the first plurality thereof;

(8) receiving the third light signal at the plurality of detectors such that each detector of the plurality thereof receives a different wavelength signal of a second plurality of wavelength signals that are characterized by different wavelengths within the third spectral range, wherein the first plurality of wavelength signals and second plurality of wavelength signals have different spectral resolutions; and

(9) providing a second plurality of output signals, wherein each output signal of the second plurality thereof is based on the magnitude of a different wavelength signal of the second plurality thereof.

27. The method of claim 18 further comprising:

(4) controlling a first separation between the first and second mirrors at a first location such that the first separation has a second magnitude, wherein one of a first maximum wavelength and first minimum wavelength of the second spectral range is based on the second magnitude;

(5) receiving the second light signal at a plurality of detectors arranged along the first direction such that each detector of the plurality thereof receives a different wavelength signal of a first plurality of wavelength signals that are characterized by different wavelengths within the second spectral range; and

(6) providing a first plurality of output signals, wherein each output signal of the first plurality thereof is based on the magnitude of a different wavelength signal of the first plurality thereof.

28. The method of claim 27 further comprising:

(7) controlling the first separation such that it has a third magnitude;

(8) providing a third light signal from the spectral filter such that it is spectrally dispersed along the first direction, the third light signal being characterized by a third spectral range that is within the first spectral range, wherein one of a second maximum wavelength and second minimum wavelength of the third spectral range is based on the third magnitude;

receiving the third light signal at the plurality of detectors such that each detector of the plurality thereof receives a different wavelength signal of a second plurality of wavelength signals that are characterized by different wavelengths within a third spectral range; and

(9) providing a second plurality of output signals, wherein each output signal of the second plurality thereof is based on the magnitude of a different wavelength signal of the second plurality thereof.

29. The method of claim 28 further comprising (10) controlling the first angle such that it has a fourth magnitude, wherein the third spectral range has a second spectral width that is based on the fourth magnitude, and wherein the first plurality of wavelength signals and second plurality of wavelength signals have different spectral resolutions.

30. The apparatus of claim 17 further comprising (4) providing the spectral filter such that each of the first mirror and second mirror is oriented at a second angle relative to a second direction when the spectral filter is in its quiescent state, wherein the second angle is not equal to 90°, and wherein the first light signal propagates along the second direction.

FIG. 1

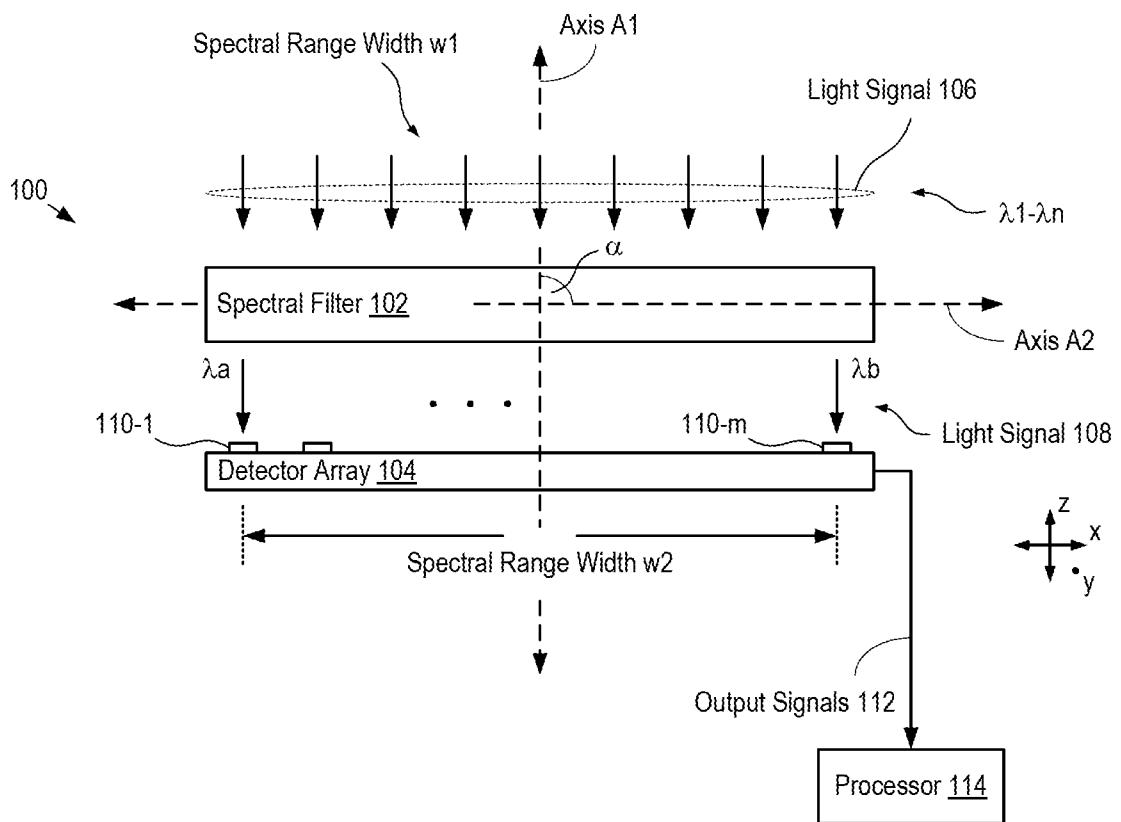

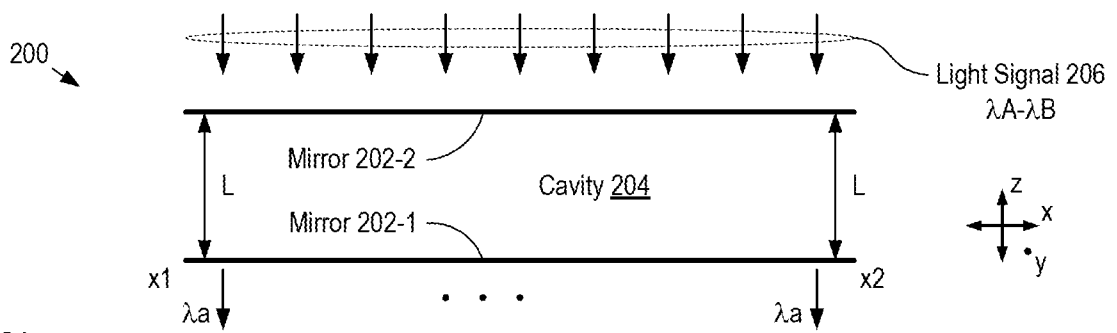

FIG. 2A

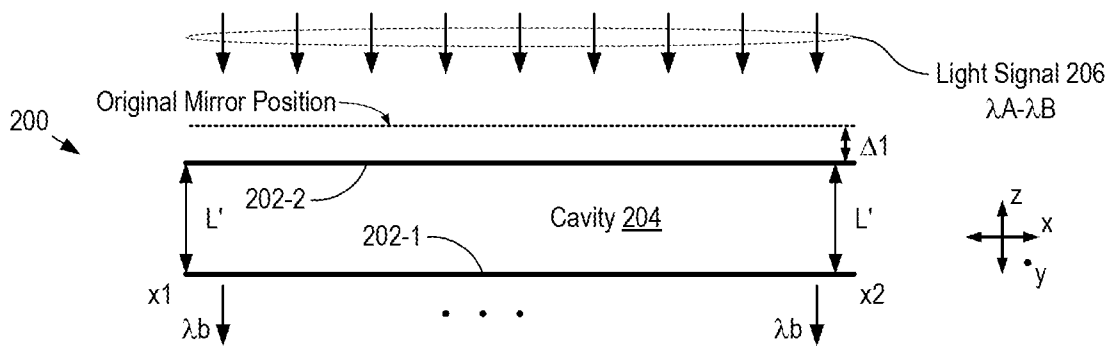
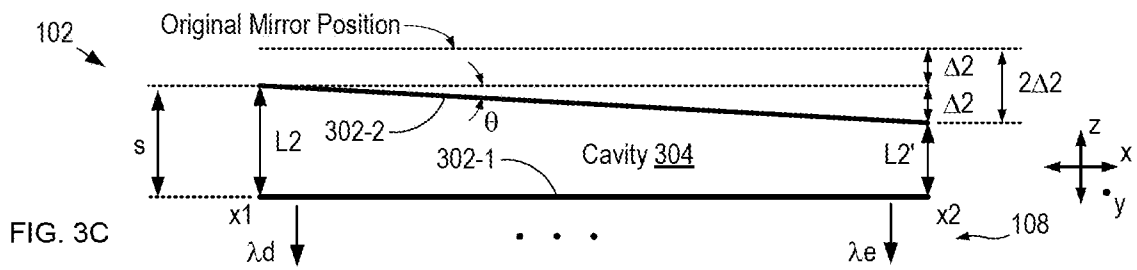
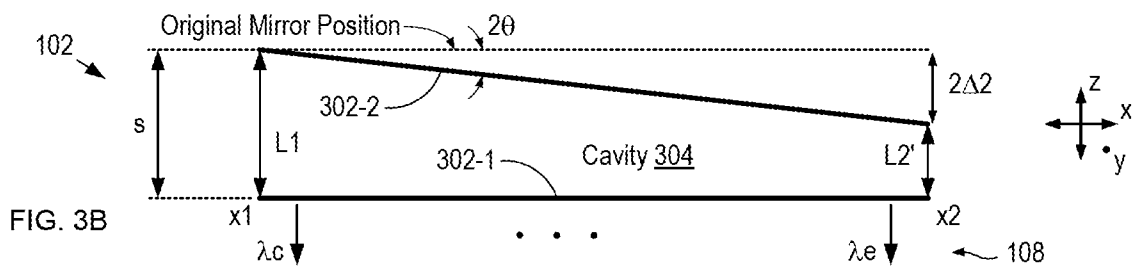
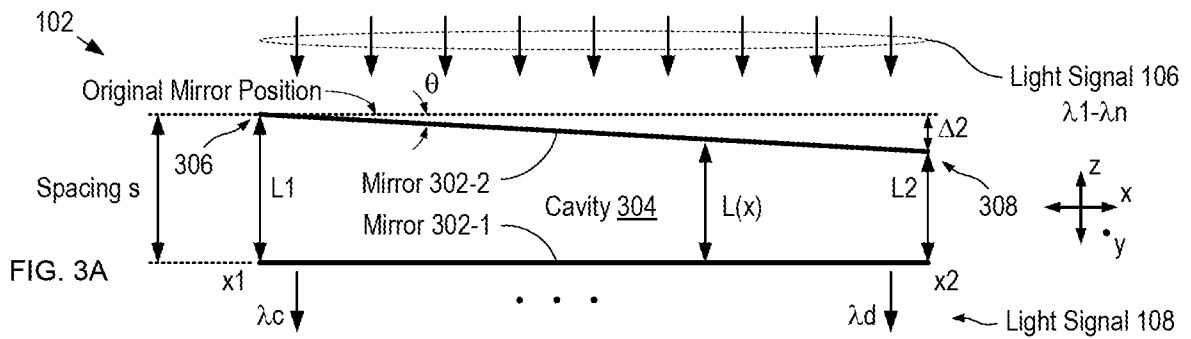

FIG. 2B



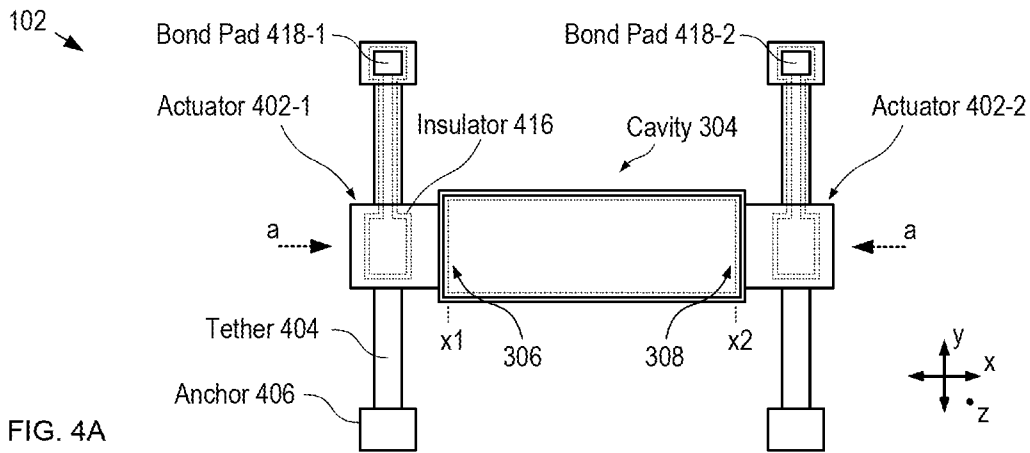

FIG. 4A

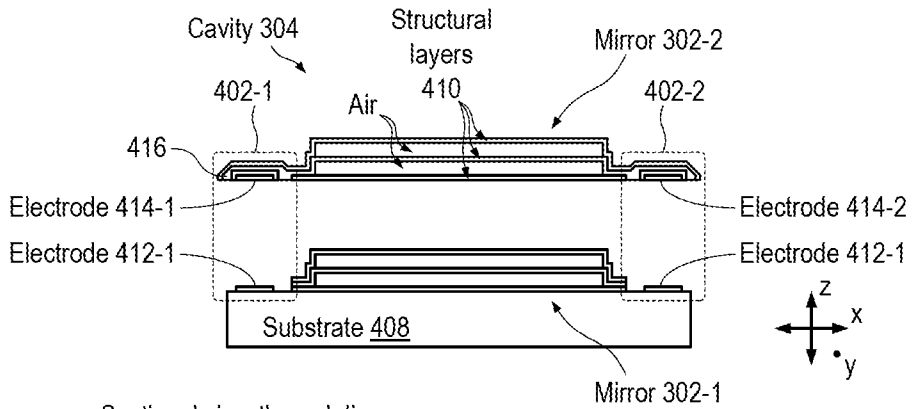

FIG. 4B

Sectional view through line a-a

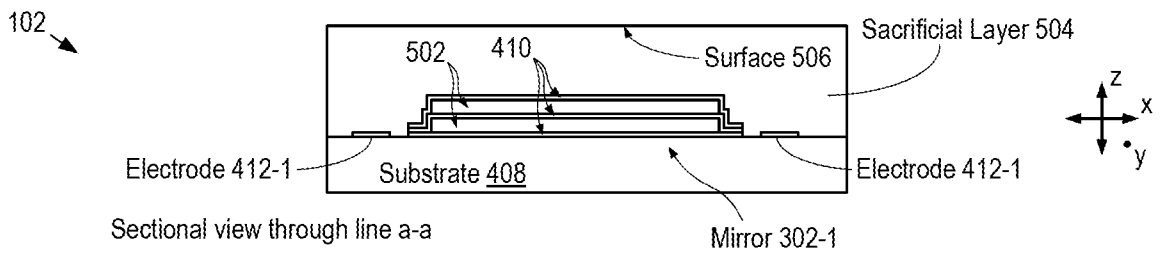

FIG. 5A

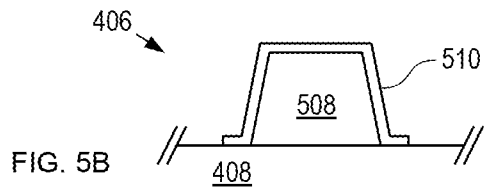

FIG. 5B

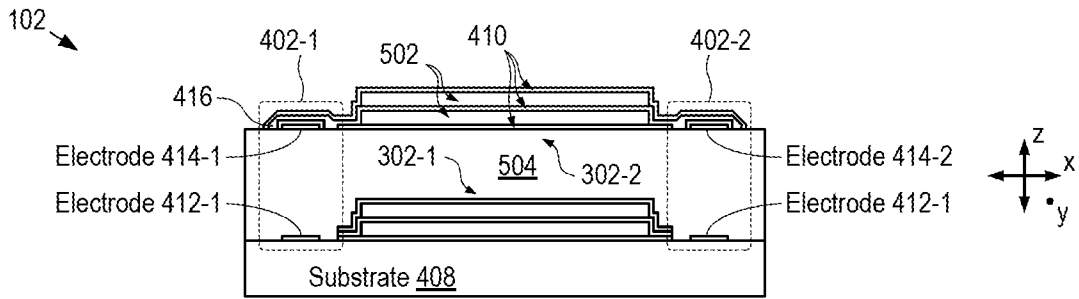

FIG. 5C

FIG. 6

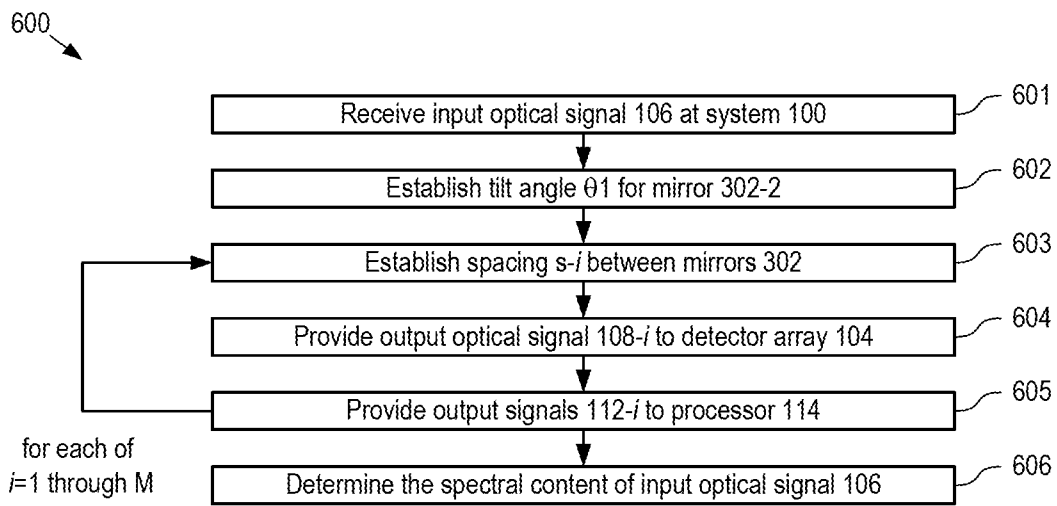

FIG. 7

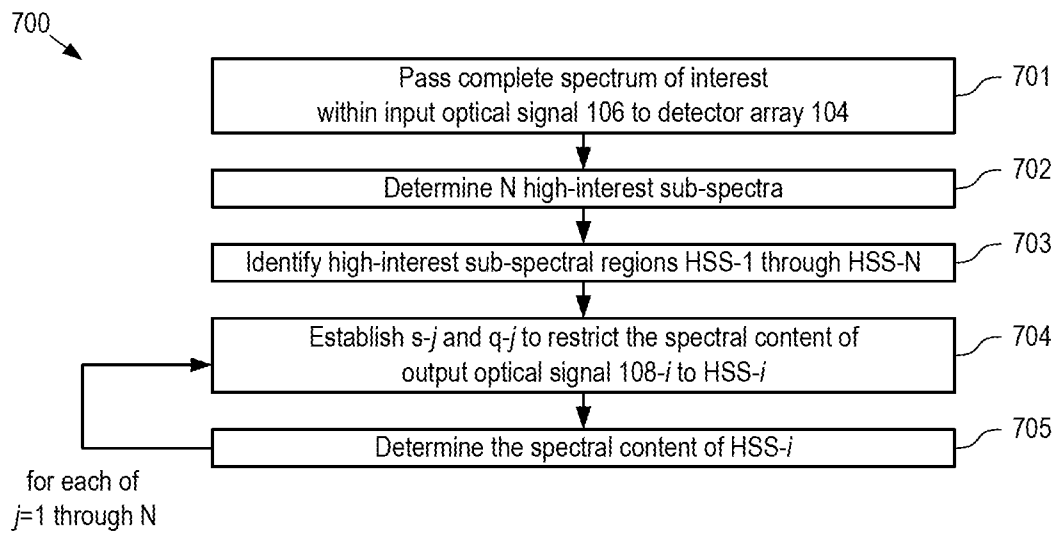
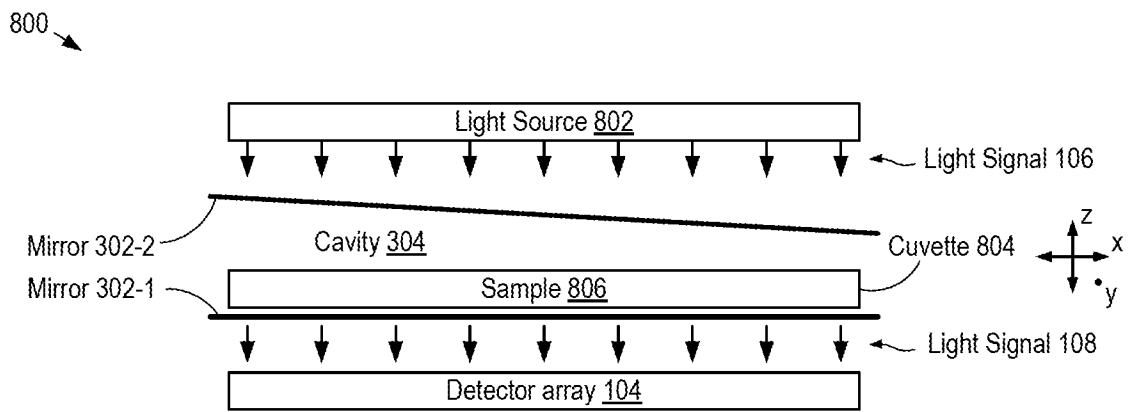

FIG. 8



INTERNATIONAL SEARCH REPORT

International application No.

PCT/US 18/34710

A. CLASSIFICATION OF SUBJECT MATTER
 IPC(8) - G01J 3/26; G02B 5/28 (2018.01)
 CPC - G01J 3/26; G01J 3/2823; G02B 5/284; G02B 26/001

According to International Patent Classification (IPC) or to both national classification and IPC

B. FIELDS SEARCHED

Minimum documentation searched (classification system followed by classification symbols)

See Search History Document

Documentation searched other than minimum documentation to the extent that such documents are included in the fields searched

See Search History Document

Electronic data base consulted during the international search (name of data base and, where practicable, search terms used)

See Search History Document

C. DOCUMENTS CONSIDERED TO BE RELEVANT

Category*	Citation of document, with indication, where appropriate, of the relevant passages	Relevant to claim No.
X	US 7,817,281 B2 (KIESEL et al.) 19 October 2010 (19.10.2010), Fig 1, 2, 4, 7, 10, abstract, col 7, ln 39-65, col 10, ln 22-38, col 13, ln 1-20, col 13, ln 34-43, col 14, ln 26-col 15, ln 18, col 16, ln 34-col 17, ln 4, col 24, ln 40-48, col 32, ln 22-59, col 34, ln 45-50	1, 5-9, 13-16, 18, 19, 21-29
---		-----
Y		2-4, 10-12, 20
---		-----
A		17, 30
Y	US 8,649,097 B2 (MITAMURA) 11 February 2014 (11.02.2014), Fig 3, abstract, col 2, ln 12-19, col 5, ln 1-col 6, ln 35	2, 3, 10, 11
Y	US 6,597,490 B2 (TAYEBATI) 22 July 2003 (22.07.2003), Fig 5a-5d, abstract, col 6, ln 46-col 7, ln 9	4, 12, 20

Further documents are listed in the continuation of Box C.

See patent family annex.

* Special categories of cited documents:

"A" document defining the general state of the art which is not considered to be of particular relevance

"E" earlier application or patent but published on or after the international filing date

"L" document which may throw doubts on priority claim(s) or which is cited to establish the publication date of another citation or other special reason (as specified)

"O" document referring to an oral disclosure, use, exhibition or other means

"P" document published prior to the international filing date but later than the priority date claimed

"T" later document published after the international filing date or priority date and not in conflict with the application but cited to understand the principle or theory underlying the invention

"X" document of particular relevance; the claimed invention cannot be considered novel or cannot be considered to involve an inventive step when the document is taken alone

"Y" document of particular relevance; the claimed invention cannot be considered to involve an inventive step when the document is combined with one or more other such documents, such combination being obvious to a person skilled in the art

"&" document member of the same patent family

Date of the actual completion of the international search

26 July 2018

Date of mailing of the international search report

27 AUG 2018

Name and mailing address of the ISA/US

Mail Stop PCT, Attn: ISA/US, Commissioner for Patents
 P.O. Box 1450, Alexandria, Virginia 22313-1450
 Facsimile No. 571-273-8300

Authorized officer:

Lee W. Young

PCT Helpdesk: 571-272-4300
 PCT OSP: 571-272-7774