

**E. BURT.**  
**Breech-Loading Fire-Arm.**

No. 160,748.

Patented March 16, 1875.

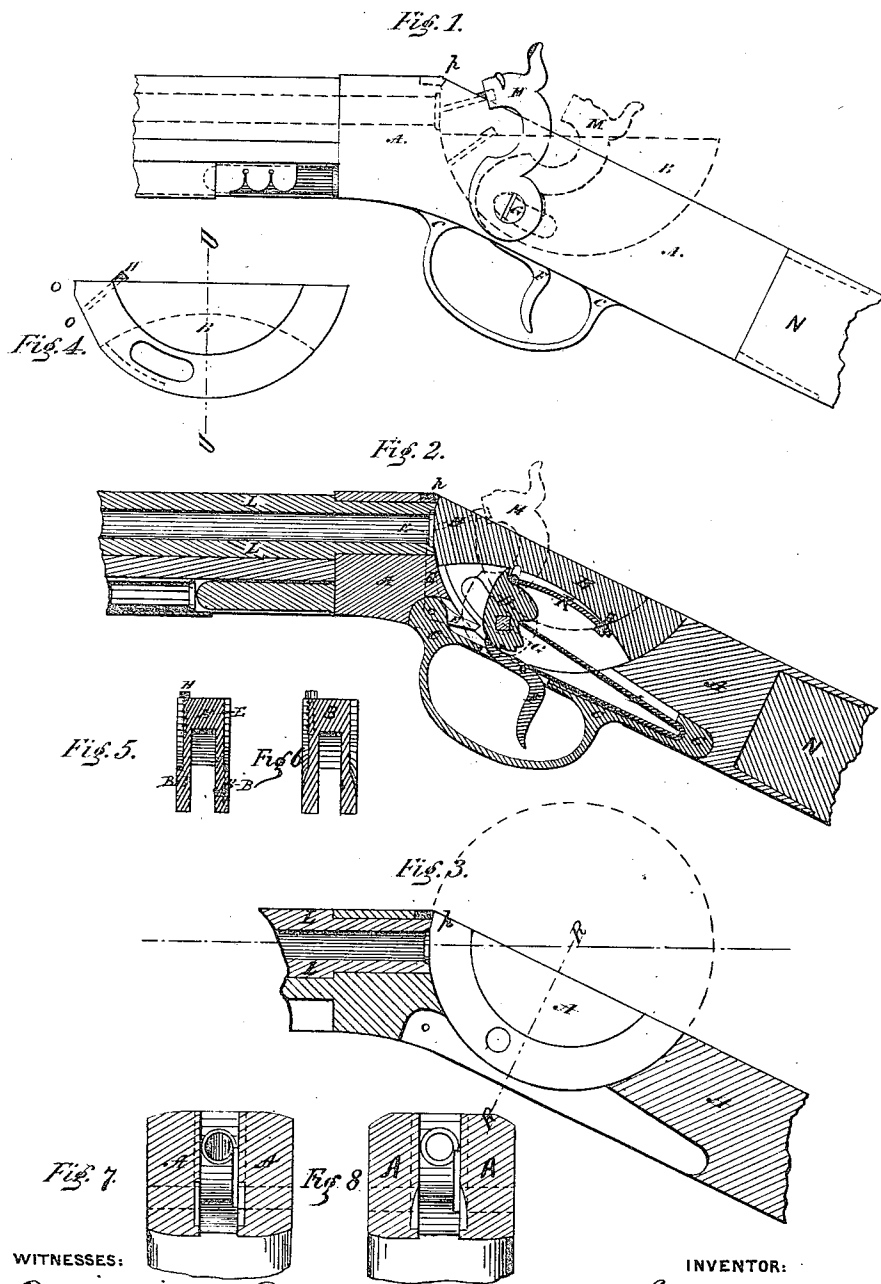

WITNESSES:  
*Benjamin C. Pole*  
*Yoon Pike*

INVENTOR:  
*Edwin Burt*  
*Pole and Pilce,*  
*attys.*

E. BURT.  
Breech-Loading Fire-Arm.

No. 160,748.

Patented March 16, 1875.

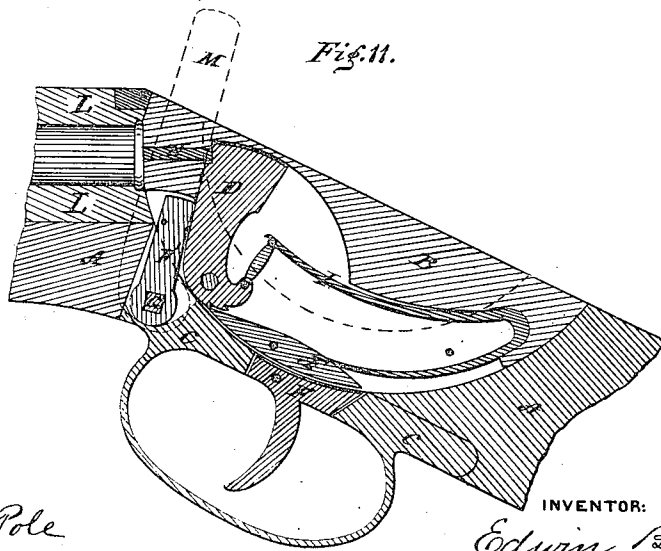
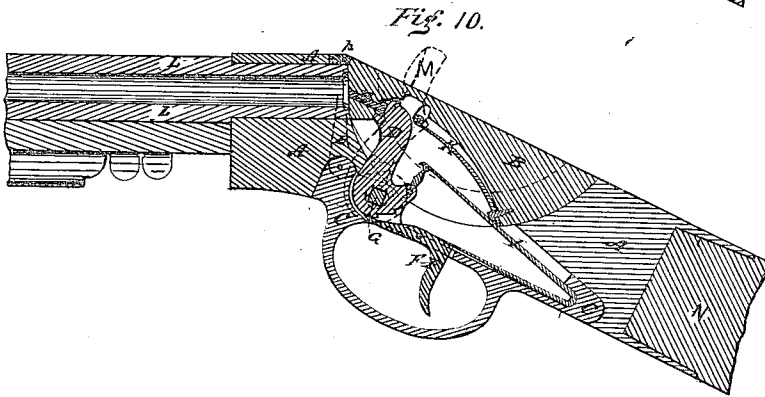
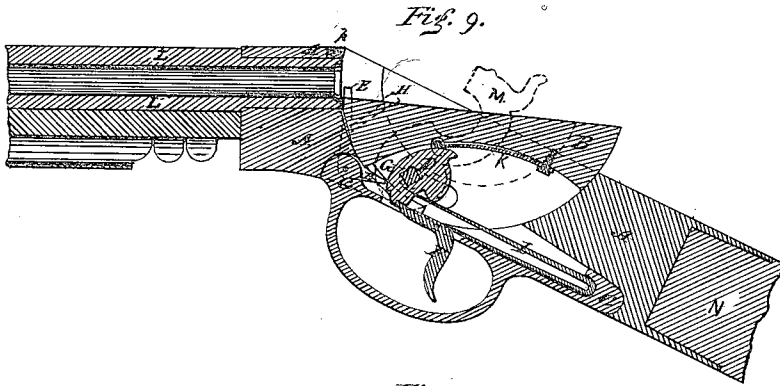

WITNESSES:

*Benjamin C. Pole*  
*Yvon Pike*

INVENTOR:

*Edwin Burt*  
*Perce and Pole*  
*attys*

E. BURT.  
Breech-Loading Fire-Arm.

No. 160,748.

Patented March 16, 1875.

FIG. 12.

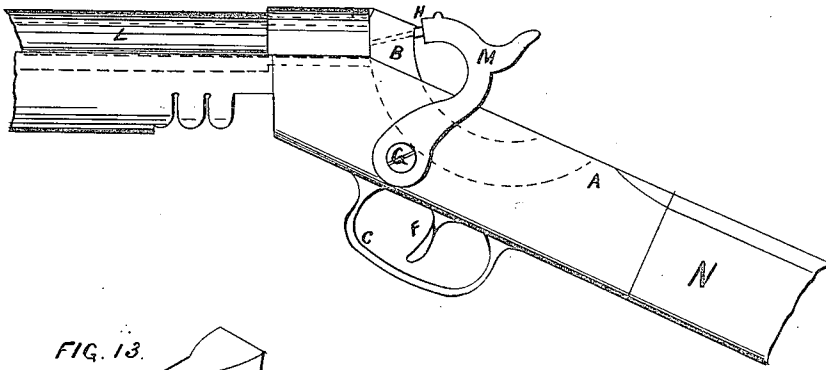

FIG. 13.

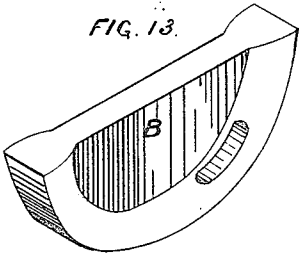

FIG. 14.

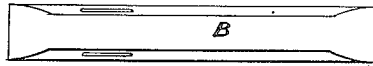

FIG. 15.

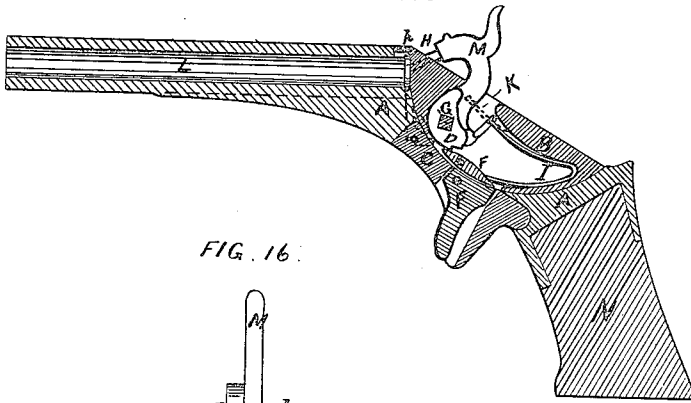
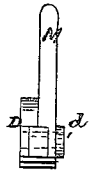

FIG. 16.



WITNESSES  
Benjamin C. Pole  
John Pike

INVENTOR  
Edwin V. Burt.  
Pole and Pike  
attys

# UNITED STATES PATENT OFFICE.

EDWIN BURT, OF WASHINGTON, DISTRICT OF COLUMBIA.

## IMPROVEMENT IN BREECH-LOADING FIRE-ARMS.

Specification forming part of Letters Patent No. 160,748, dated March 16, 1875; application filed November 20, 1874.

*To all whom it may concern:*

Be it known that I, EDWIN BURT, of city of Washington, in the District of Columbia, have invented certain new and useful Improvements in Breech-Loading Fire-Arms; and I do hereby declare that the following is a full, clear, and exact description thereof, which will enable others skilled in the art to which it pertains to make and use the same, reference being had to the accompanying drawings, and to the letters of reference marked thereon, which form a part of this specification.

The object of my invention is to improve that class of fire-arms in which the rear end of the barrel is opened by a movable breech-block for the insertion of the cartridge, which arms are known as breech-loaders; and to construct a fire-arm which shall be strong and safe to handle, simple and easily made, symmetrical in appearance, without any unseemly projections above or behind the opening of the breech to interfere with the eye of the operator in sighting or cleaning the barrel, and certain new and novel constructions to be hereinafter described.

My improvement consists in an entirely new form of breech-block, it being made in the form of a segment of a circle, and revolving or moving around its center in grooves provided for it in the receiver, by which it gains a downward and backward motion at the same time; and it further consists in attaching the striker, trigger, and mainspring, which constitute the entire lock, to the guard, and the guard to the receiver by means of a main connecting-pin, so that by removing this one pin the entire lock and breech-block may be taken out without detaching the different parts of the lock from each other; in the arrangement of the hammer or striker so as to be upon the outside of the piece, and leaning over in such a position as to easily hit the firing-pin. In this case the hammer, in being drawn back to the position of half-cock, automatically opens the breech by a backward and downward motion of the breech-block, ejecting the exploded cartridge and permitting the charging by a new cartridge—all of which is hereafter represented and more fully described.

In all the figures the same letters represent the same parts described herein.

A represents the receiver; B, the breech-block; C, the guard; D, the striker and tumbler; E, the extractor; F, the sear and trigger; G, the main connecting-pin; H, the firing-pin; I, the mainspring; K, the catch-spring; L, the barrel; M, the thumb-lever or hammer; N, the stock; *p*, the breech-block stop.

Figure 1 is a side elevation of so much of a breech-loading fire-arm as will serve to show the appearance of an arm with my improvements, and the position of the hammer and breech-block; also showing in dotted lines the position of the breech when the arm is half-cocked. Fig. 2 is a longitudinal vertical section of the same, showing the different parts in position, the hammer pressing upon the firing-pin, and of that modification of my improvement in which the firing-pin is struck from the outside of the breech-block by an ordinary hammer, which also serves as a lever to open the breech-chamber, as shown in Fig. No. 1. Fig. 3 is a vertical section of the receiver, showing the curved grooves in which the breech-block works, also the opening for the guard. Fig. 4 is a side elevation of the breech-block. Fig. 5 is a section of Fig. 4 in line U U. Fig. 6 is a section of Fig. 4 in line U U when the grooves are rounded. Fig. 7 is a section of Fig. 3 on line R R. Fig. 8 is a section of Fig. 3 on line R R when the receiver-grooves are rounded. Fig. 9 is a longitudinal vertical section, showing the breech opened ready for loading and the hammer at half-cock. Fig. 10 is a sectional elevation of another modification of my improvement, in which the firing-pin is struck from the inside of the breech-block by the striker and tumbler combined in one piece, and in which the center-block, with the extractor, is attached to the guard, and the guard to the receiver, by the main connecting-pin. Fig. 11 is a section of another equivalent or modification of my improvement, in which the entire lock is within the breech-block, and is cocked by the lever M in opening the breech-block, as by the lever in Fig. 10. Fig. 12 is a sectional side elevation of my improvement when the same is adjusted for small-caliber rifles or fire-arms. Fig. 13 is an isometrical view of the breech-block when the same is adjusted with rounded

grooves. Fig. 14 is a plan of No. 13. Fig. 15 is a sectional elevation of my improvement when adjusted to pistols. Fig. 16 is a view of the hammer and tumbler combined for use in pistols, as Fig. 15.

To enable those skilled in the art to make and use my improvement, I will proceed to describe its construction and operation.

To construct my breech-block B, I take, for an ordinary-sized fire-arm, a piece of metal made in a circle of about four (4) inches diameter. This is turned in a lathe perfectly round, and is then trimmed out in the center, on each side, so as to leave a projecting ring around the edges on each side, as shown in Fig. 4, and these projecting rings are to be made either rounding or with square shoulders, as shown in Figs. 5 and 7; but, for the purpose of withdrawing the cartridge, the rounded shoulders are preferable, Figs. 6 and 8. This operation is all performed by the lathe, and the round piece of metal is then divided and the parts worked down to the required size, making two breech-blocks by one operation.

The breech-block is flattened slightly at the points *o*, Fig. 4. By this simple construction two breech-blocks are externally prepared in one operation. These pieces are then taken and milled out, as shown in Fig. 4, and the slots drilled for the action of the tumbler, Figs. 4 and 13. The receiving-piece is made the counter for the reception of the breech-block. This can be made so that the grooves are rounding, Fig. 8, or square, Fig. 7, to receive corresponding shoulders in the breech-block. There is also provided a stop, *p*, to arrest the breech-block when closed, which is a piece of metal let into the edge of the ring, holding the barrel. In the manufacture of this receiver there is provided the recess for the guard, and the hole is drilled for the main connecting screw or pin. This connecting-pin is provided with a square part for the tumbler to act on. The tumbler has a collar trimmed on it, Fig. 16, *d*, fitting into a recess trimmed to meet it, either in the guard or breech-block, so that, by withdrawing the main connecting-pin *G*, the tumbler *D* maintains its position with reference to the mainspring and other parts. The mainspring *I* is flat, and in one instance made, as in Fig. 11, to be contained in the breech-block, and in an equivalent, Figs. 2 and 10, in the guard; but in both instances it is known as a double spring, acting with force upon the tumbler or striker *D* and upon the sear *F*, Fig. 11. This construction necessitates the introduction of the piece *F'*, for the purpose of forcing the striker back, preparing the arm for loading, as in the instance of the hammer hereinbefore described. There can also be used in the breech-block the spiral form of mainsprings. At the bottom of the middle part of the breech-block there is placed a flat spring, *K*, having two ears at its end, screwed into the block, and also being held by the ears to make it solid, and is in such a position, Fig. 2, that it will

come in contact with the tumbler *D* when the same is being drawn back to half-cock, and thereby forces the breech-block *B*, to which it is attached, back, as desired. As the hammer goes into the half-cock notch the tumbler *D* becomes clear of this spring *K*, thereby permitting the piece to be loaded at half-cock, and the breech-block independently closes, and the hammer *M*, being moved to full cock, leaves the breech-block stationary. It should, however, be closed by the operator at half-cock; but upon the tumbler's returning to the position of pressing upon the firing-pin, it will, by automatic action, cause the breech-block to close the breech, and also hold it in that position, so that the blow from the hammer, in firing, will not move the breech-block.

The receiver falls away at such an angle as to permit the true center of the breech-block (and which it revolves around in its action of opening and closing the breech) being also the center of the barrel, giving a clear sight through the barrel, (see Fig. 3,) which is shown in dotted lines.

The breech-block is flattened at *O*, Fig. 4, so that, should the cartridge not be forced quite in, the flat of the breech-block will force it into position, and the action of the tumbler *D* underneath and stop *p* above holds the breech-block firmly.

The cartridge-extractor is of an ordinary construction, and may be placed upon the main connecting-pin *G* or on another pivot; but in each case it is acted upon by the motion of the breech-block *B*, by coming in contact with it just as it is arriving at the position of half-cock.

To operate my improvement, I will suppose the piece as just having been discharged, and with the empty shell in the barrel. The operator proceeds to recock the piece, and draws back the hammer or the lever *M*, as the case may be. Upon so doing the tumbler becomes engaged in the spring *K* and forces the breech-block *B* downward and backward. Continuing this motion, the short end of the lever of the extractor *E* becomes engaged, and the long arm forces the empty shell from the barrel of the piece. The position of half-cock is now arrived at. The barrel is open, ready for recharging or for cleaning, in which latter case there is a clear sight through the barrel, as shown in Fig. 3. The new cartridge is inserted, and the operator, by pressing upon the rear ends of the breech-block *B*, causes it to move forward and upward to position of closed breech. He then, in the ordinary manner, cocks the piece and fires.

Should the operator, however, by neglect, omit to close the breech, it will be closed by the action of the tumbler, and the gun discharged without harm.

What I claim as my invention, and desire to procure by Letters Patent, is as follows:

1. The breech-block *B*, made in the form and manner herein described, and for the purpose set forth.

2. The combination herein described of the hammer or striker, catch-spring K, and the breech-block, whereby the breech is opened by half-cocking the arm, and is then left free to be closed by thumb of the operator or the hammer, upon discharge.

3. The arrangement of the lock with the

guard, and the attachment of the guard to the receiver, in the manner and for the purposes herein specified.

EDWIN BURT.

Witnesses:

J. T. COLDWELL,  
HARRY H. BACON.