



(12) **United States Design Patent**
Stoffel et al.

(10) **Patent No.:** **US D958,724 S**
(45) **Date of Patent:** **** Jul. 26, 2022**

(54) **VEHICLE SEAT**

OTHER PUBLICATIONS

(71) Applicant: **Zoox, Inc.**, Foster City, CA (US)

Complete Console Front Floor Fixed Fits 11-19 SIENNA 647416, ebay.com, Retrieved Date: Mar. 23, 2022, p. 1, from https://www.ebay.com/itm/234289917213?_trkparms=amclksrc%3DITM%26aid%3D1110006%6algo%3DHOMESPLICE.SIM%26ao%3D1%26asc%3D237732%26meid%3D4dac6b163e6745bb82c40d37bf5d3376%26pid%3D101196%26rk%3D1%26rkt%3D12%26sd%3D265589161667%26itm%3d234289917213%26pmt%3D1%26noa%3D0%26pg%3D2047675%26algv%3DSimplAMLv9PairwiseWithPLXWebFitmentFilter&_trksid=p2047675.c101196.m2219&amdata=cksum%3A2342899172134dac6b163e6745bb82c40d37bf5d3376%7Cenc%3AAQAGAAACEHYfk%252BgaHq%252FN50vXtH4911wJe1SE71JNjXHgLoBVqDnSxUUV9Hh1j64WDGUP9bj8RI12rAHjdHQvqdBziwvavdCaKOvNNxG1hq0X6i0tjuFq9fchBF3eGPXu3E9p6mk6LRmW3ZJZmxkiQS3CFFIZMNZFkuToFMi7SQ4UpapTJwpG3%252F88umgppYzvzzPYLI38rX8exObcDX8mKIHq5B1BTs8LW3UdQBKhD8JKkR%252FTMp%252FZ9VpDMB%252BKji4JZFgDvfhCJOHuQZjOgTkYju1ypwFr0TeqTHhmJpBR27TLwqieZh19aayPyHzGu7FIER8u2t%252FLAi63gFk6PA0gGEQZGGfbXV7wsBo3uUXhte7q6p1kdzPab6gbzO8NwEuHXi280WpKHauhzX%252FG8Tpt2akbvFwWUaXAUxc%252F7wMIF5252FHJzPFs%252FR8S3vLNMI6VdUU0mvPBS9BAMLpWxCh1HHF4Vly3v9uGWt8JfhhbHhJRxbLD8RHP%252FbPW9hjtNMMQianrQePxNPHt1HVVo2KYXOPmhfTrQexeqSgAdr7Oyc9IiX1NW8Rug1VwtZMDV6k6TfUrp9r3IGv74Nsi1QW7tdYmK27keq%252BE07c9t2sUB2RA%252FHiaHFyWs5XFzoz7qbix6nDqmlXrv1gV3FN4iYGtYJw4bS%252FJd3AetnbEr2YouR32AX6qe%252Bat8EZQ3WqN1bB5gQbk1XqmnXpeA%253D%253D%7Campid%3APL_CLK%7Cclp%3A2047675 (Year: 2022).*

(73) Assignee: **Zoox, Inc.**, Foster City, CA (US)

(**) Term: **15 Years**

(21) Appl. No.: **29/715,618**

(22) Filed: **Dec. 3, 2019**

(51) **LOC (13) Cl.** **12-16**

(52) **U.S. Cl.** **D12/419; D6/356**

(58) **Field of Classification Search**

USPC D6/334-336, 356, 364, 366, 367, 374, D6/375, 381, 716, 716.1, 716.4, 716.5; D7/553.3, 553.4, 553.5; D12/400, 411, D12/419
CPC . B60N 2/00; B60N 2/64; B60N 2/643; B60N 2/58; B60N 2/646; B60N 2/66; B60N 2/68; B60N 2/686; B60N 2/80; B60N 2/803; B60N 2/4249; B60N 3/002; B60N 3/101; B60N 3/103

See application file for complete search history.

(56) **References Cited**

U.S. PATENT DOCUMENTS

D221,217 S *	7/1971	Beychok	D12/419
D223,681 S *	5/1972	Whitaker	D12/419
D341,521 S *	11/1993	Norbury	D7/553.4
5,788,324 A *	8/1998	Shea	B60N 3/101
				297/411.32
D434,721 S *	12/2000	Lieberman	D12/419
2016/0107550 A1 *	4/2016	Hwang	B60N 3/002
				297/161

(Continued)

Primary Examiner — Mimosa De

(74) *Attorney, Agent, or Firm* — Lee & Hayes, P.C.

(57) **CLAIM**

The ornamental design for a vehicle seat, as shown and described.

DESCRIPTION

FIG. 1 is a top perspective view of a vehicle seat;
FIG. 2 is a bottom perspective view thereof;

(Continued)

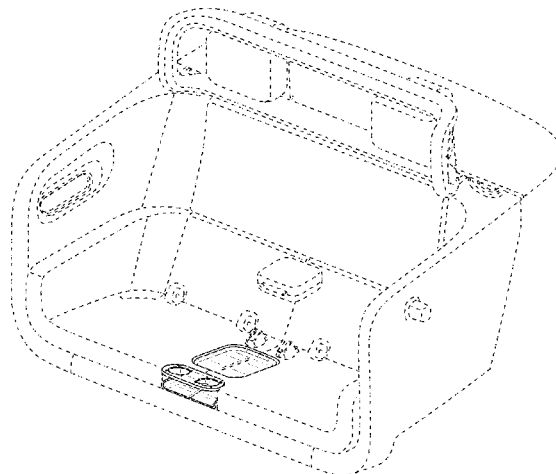

FIG. 3 is a front view thereof;

FIG. 4 is a back view thereof;

FIG. 5 is a left-side view thereof;

FIG. 6 is a right-side view thereof;

FIG. 7 is a top view thereof; and,

FIG. 8 is a bottom view thereof.

The dashed broken lines depict portions of the vehicle seat that form no part of the claimed design.

1 Claim, 8 Drawing Sheets

OTHER PUBLICATIONS

The Japanese Office Action dated Japanese Patent Application No. 2020-010991, a counterpart of U.S. Appl. No. 29/715,618, 3 pages.
Chinese Office Action dated Jun. 11, 2021 for Chinese Patent Application No. 202030272958.2, a counterpart foreign application of U.S. Appl. No. 29/715,618, page.
Chinese Office Action dated Sep. 1, 2021 for Chinese Application No. 202030272958.2, a foreign counterpart to U.S. Appl. No. 29/715,618, 1 page.
Japanese Office Action dated Sep. 17, 2021 for Japanese Patent Application No. 2021-004543, a foreign counterpart to U.S. Appl. No. 29/715,618, 3 pages.

* cited by examiner

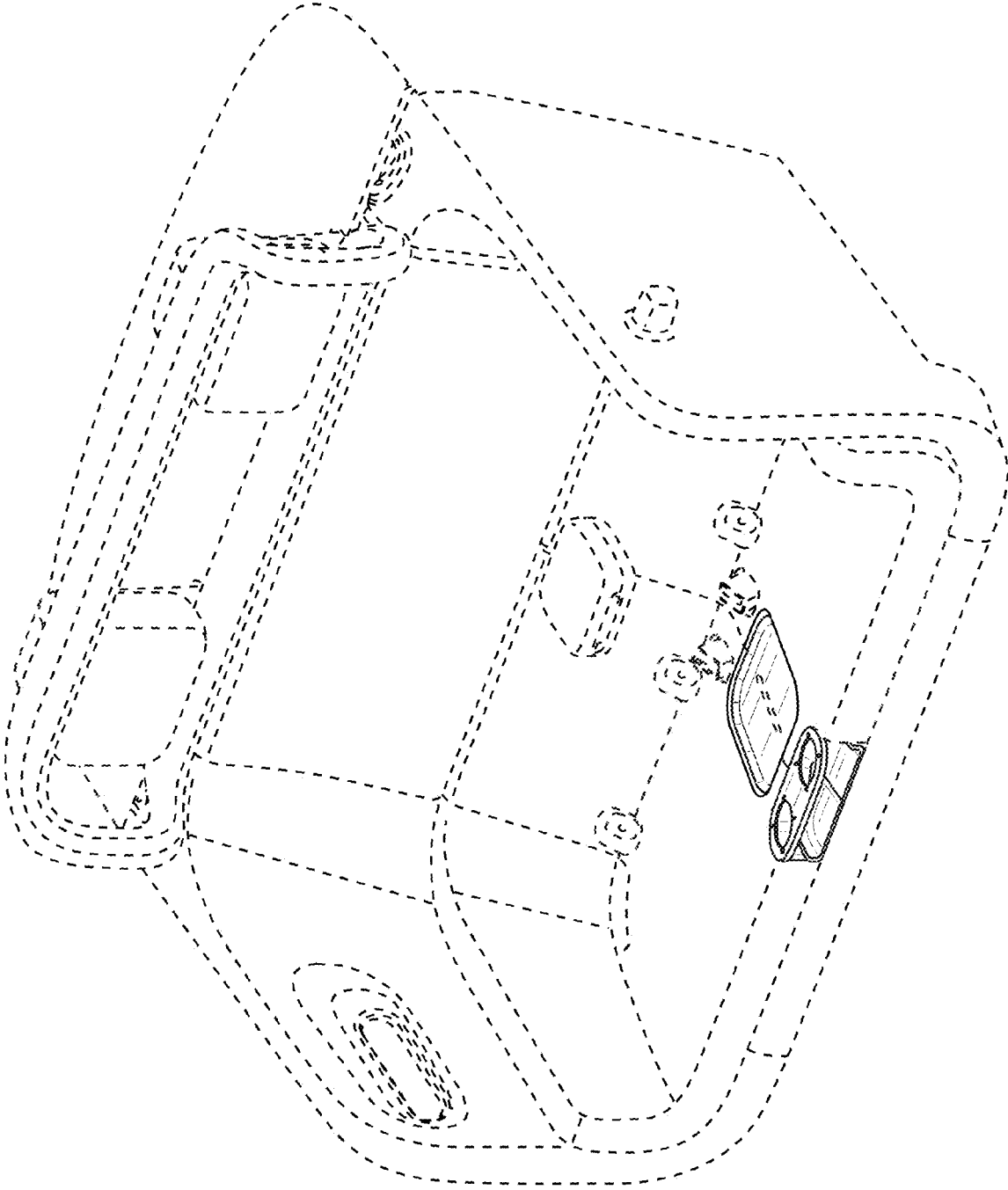

FIG. 1

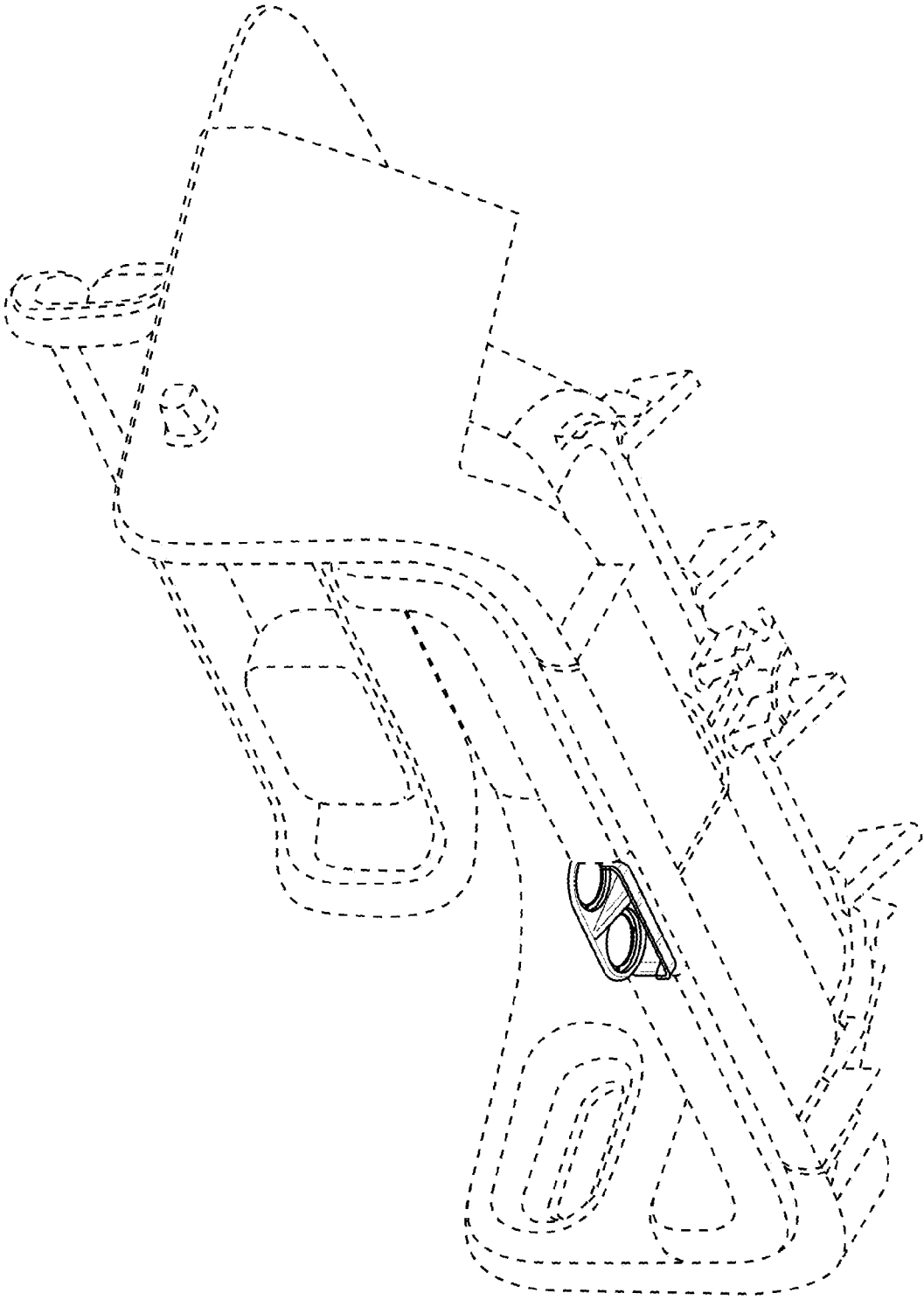

FIG. 2

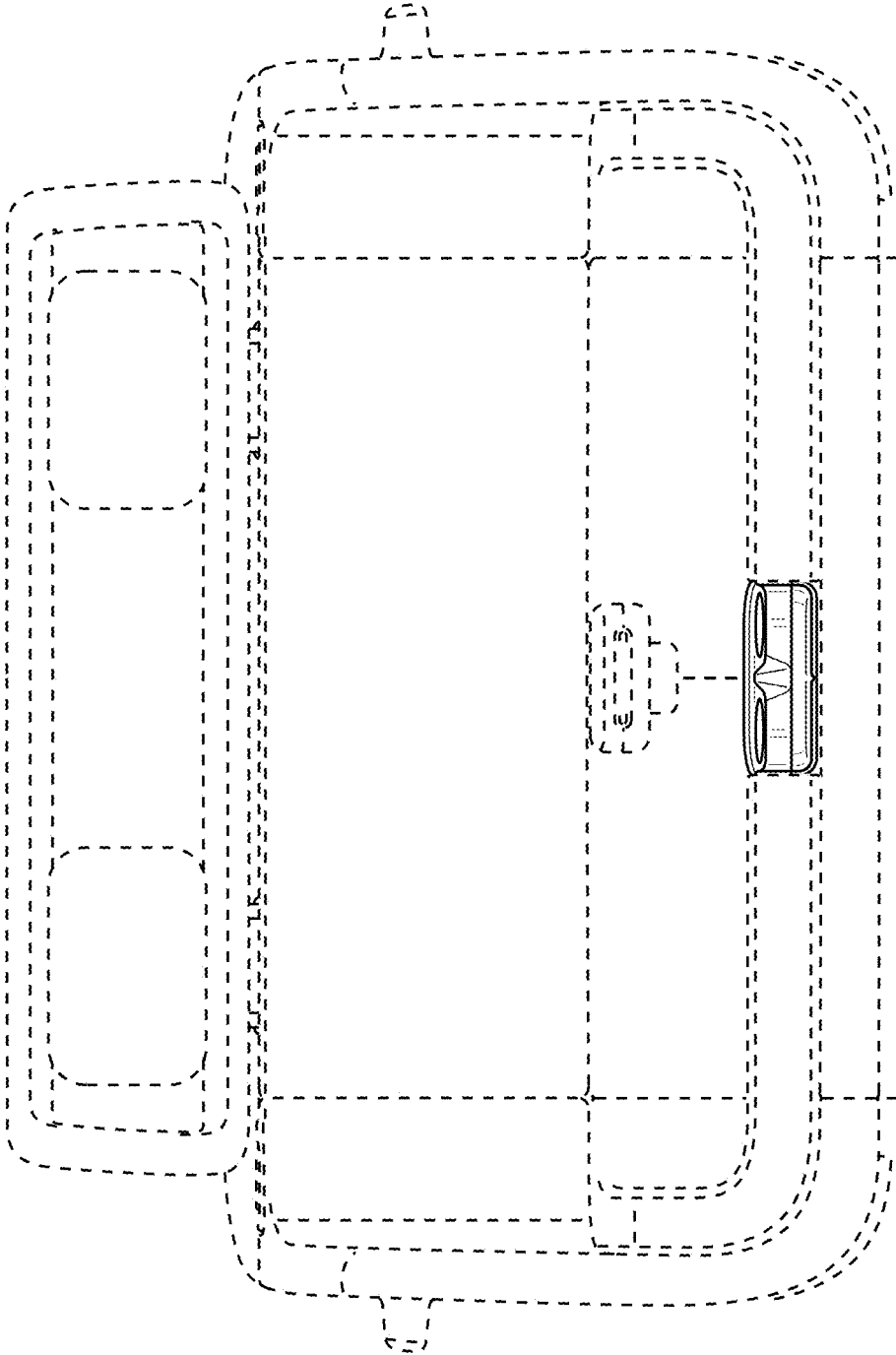

FIG. 3

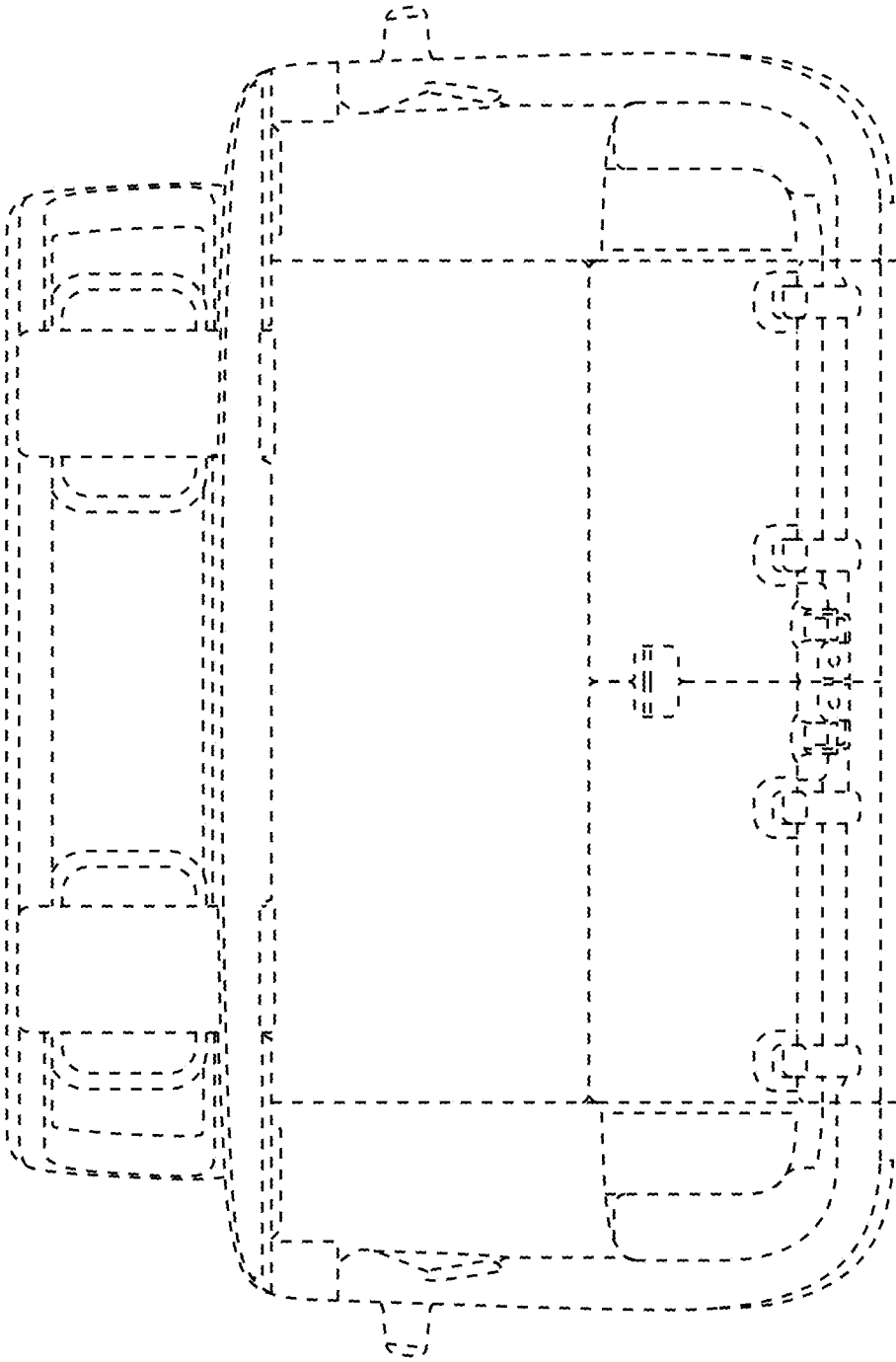

FIG. 4

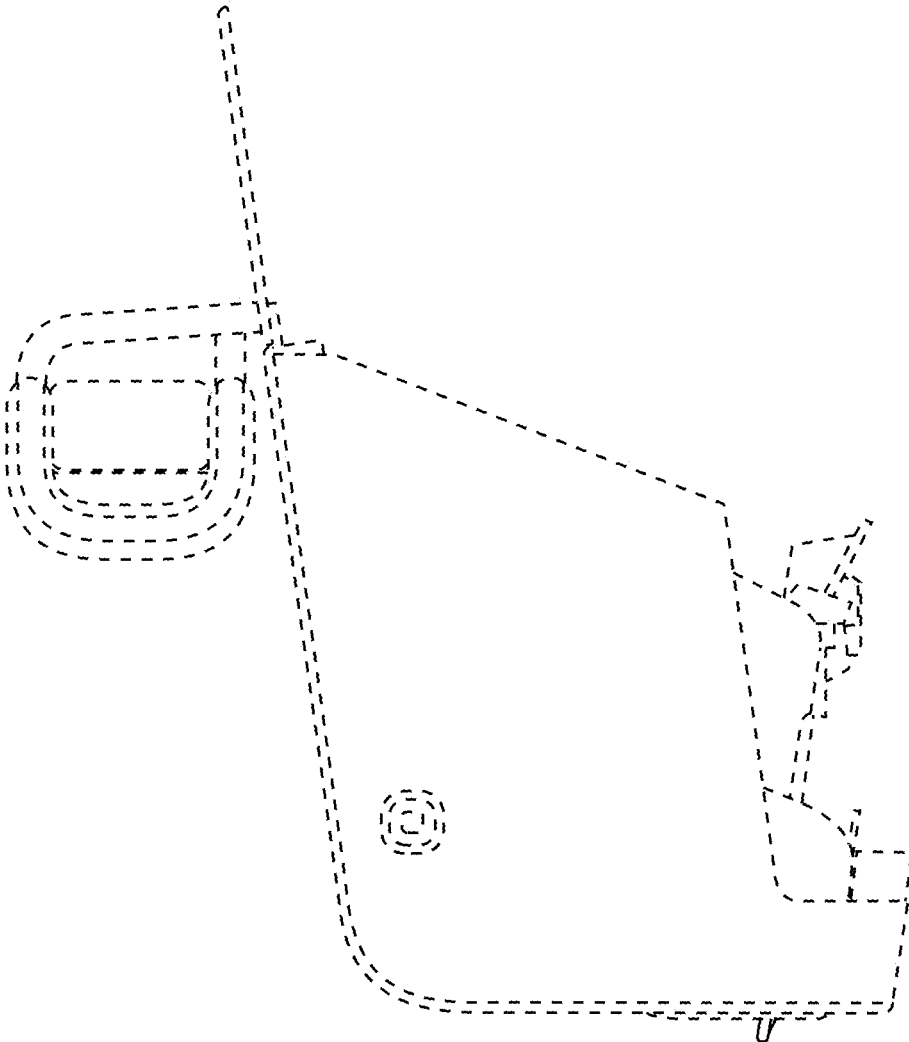

FIG. 5

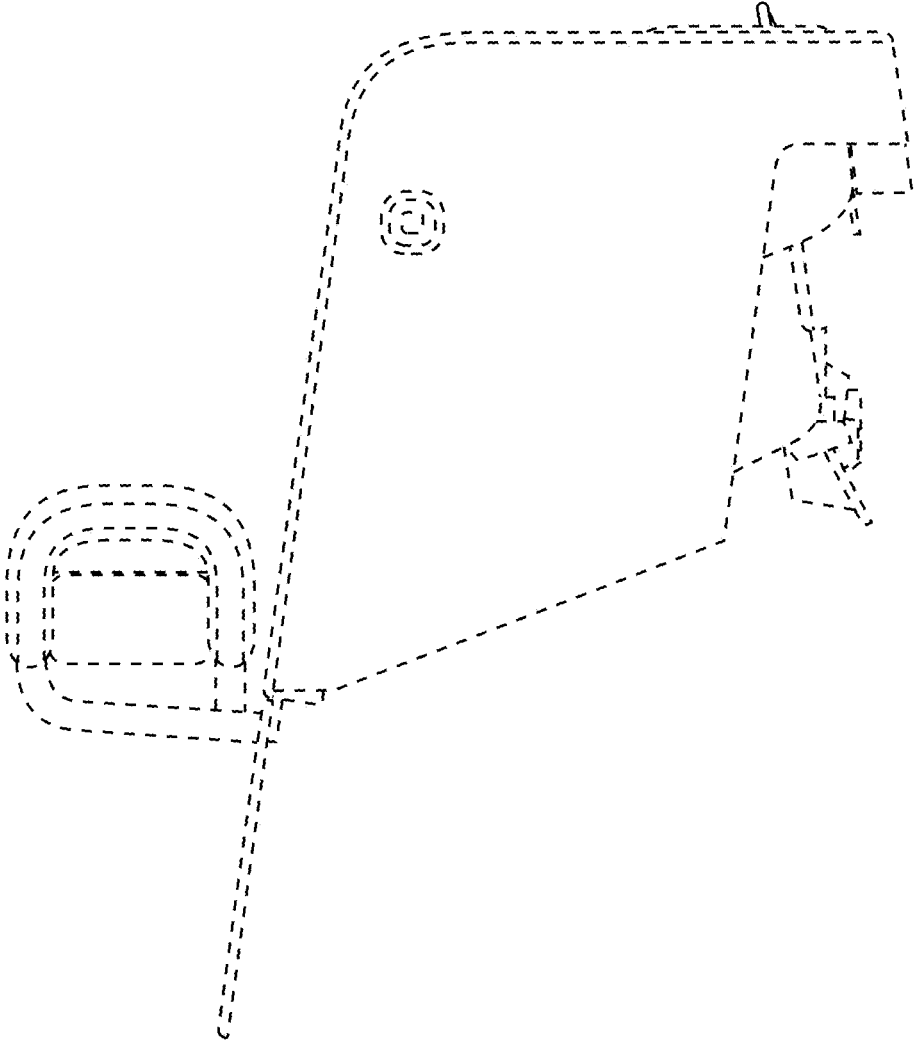

FIG. 6

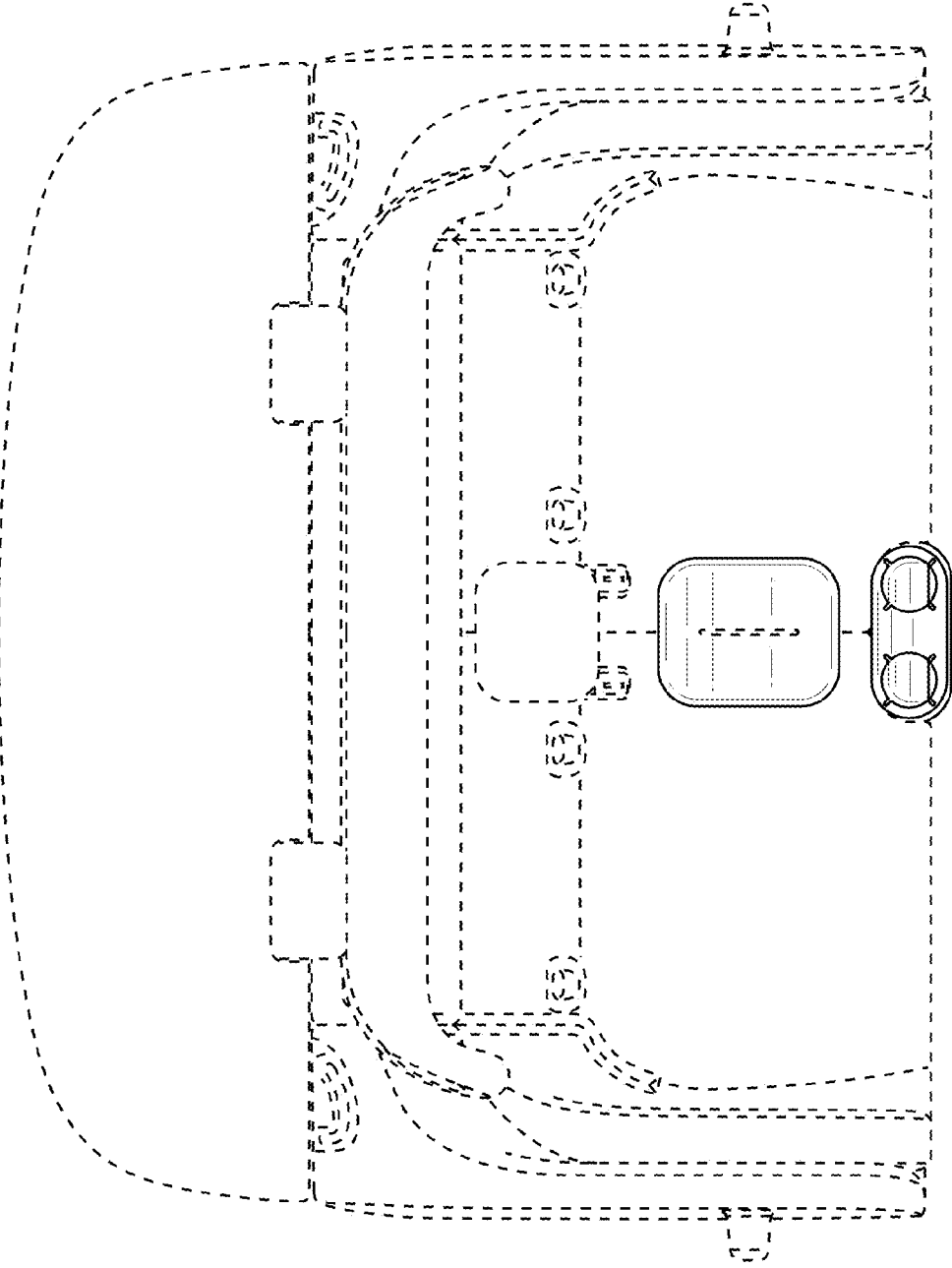

FIG. 7

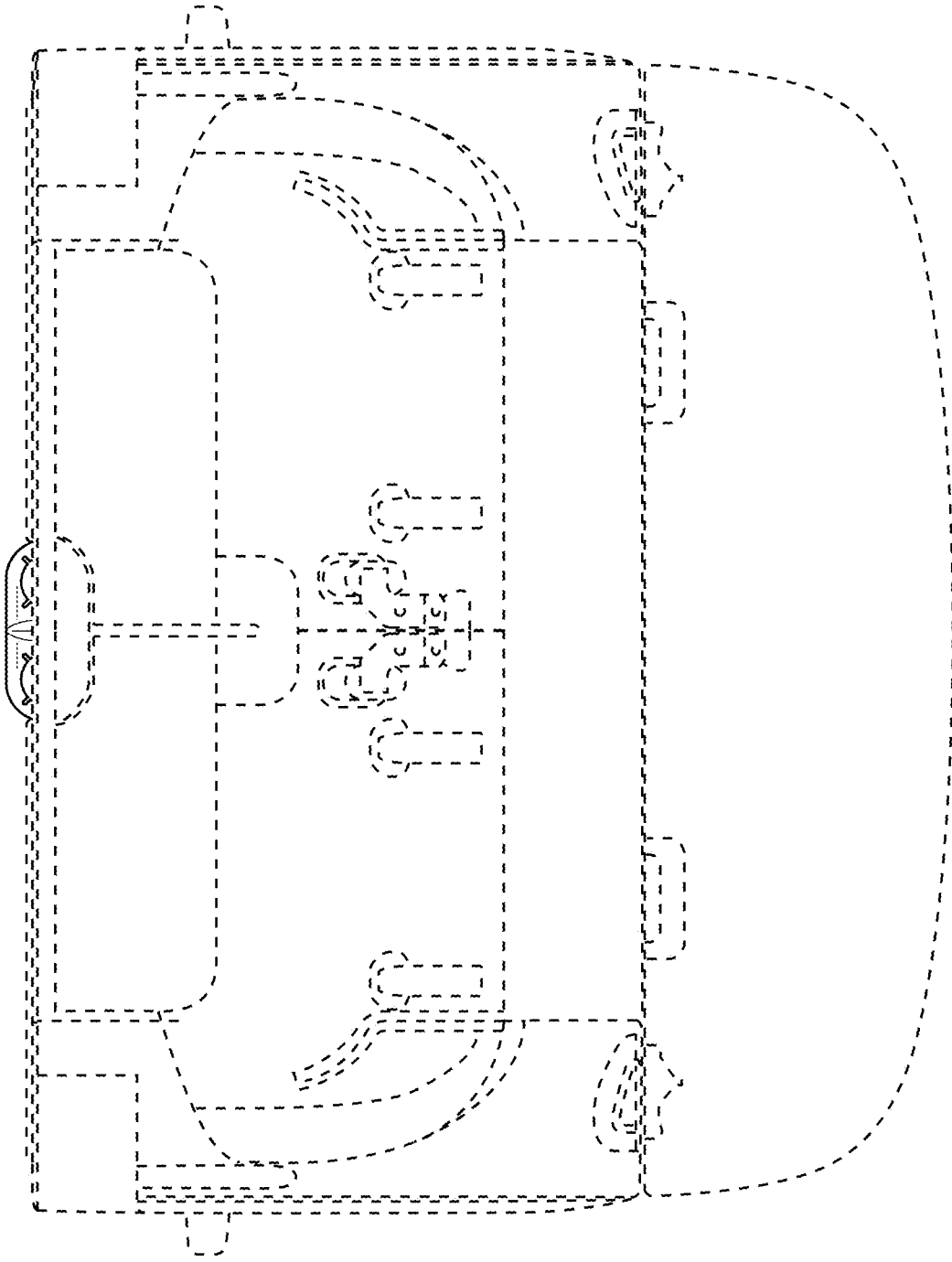

FIG. 8