

[54] **CHINESE CHARACTER (KANJI) TELEPRINTER OR A CHINESE CHARACTER (KANJI) PUNCHING TYPEWRITER OR SIMILAR APPARATUS**

[75] Inventors: **Shimeo Ogawa, Kitakami; Koji Shinozaki, Hanamaki; Shinpei Chida, Kitakami, all of Japan**

[73] Assignee: **Yamura Kabushiki Kaisha Shinkoseisakusho, Hanamaki-shi, Iwate-ken, Japan**

[22] Filed: **Jan. 31, 1972**

[21] Appl. No.: **221,937**

[52] U.S. Cl. **197/1 A, 178/25**

[51] Int. Cl. **B41j 3/50**

[58] Field of Search **197/1, 56, 58, 6.2, 17; 178/25, 17 R, 17 A, 17 B, 36, 33 R**

[56] **References Cited**
UNITED STATES PATENTS

2,639,017	5/1953	Croucher	197/6.2 X
2,986,256	5/1961	Weaver	197/56
3,035,677	5/1962	Henderson	197/56 X
3,217,853	11/1965	Gentilini	197/17
3,373,857	3/1968	Lapointe	197/17 X

Primary Examiner—Robert E. Pulfrey
Assistant Examiner—R. T. Rader
Attorney, Agent, or Firm—Wenderoth, Lind & Ponack

[57] **ABSTRACT**

A teleprinter apparatus for typing or tape punching Roman alphabet characters, numbers, and symbols, and Chinese characters includes a platen and means for spacing and rotating the platen and operating the tape punching means. Code unit receiving means is provided for receiving multi-element code units representing characters, symbols, numbers and functions to be carried out by the apparatus, and the apparatus has

a plurality of function means responsive to receipt of function code units for driving the apparatus for carrying out the functions represented by the function code units. Conversion function means is provided which is responsive to the receipt of conversion function code units for converting the apparatus from a normal operational state in which it prints Roman characters, numbers and symbols to a Chinese character operational state in which it prints Chinese characters and vice versa. One of said function means is spacing function means for driving the platen spacing means for every two code units received by said code unit receiving means, and this spacing function means is coupled to the conversion function means for actuation when the apparatus is in the Chinese character operational state. The apparatus has printing means for printing characters, symbols and numbers on the platen, and transmission means are coupled to the code unit receiving means for receiving single code units and when they are for characters, numbers and symbols to be printed, transmitting them, further transmission means are coupled to the code unit receiving means for receiving code units corresponding to characters, numbers and symbols, storing them and then transmitting them when the apparatus is in the normal operation state and when the apparatus is in the Chinese character operational state transmitting the second code unit of each pair directly to the printing means. One of said function means is normal printing function means coupled to the further transmission means for causing the further transmission means to store the code unit and transmit it to the printing means. One of said function means is Chinese character printing function means coupled to the further transmission means for coupling the further transmission means directly to the printing means, and one of the function means is tape punching function means for coupling the respective transmission means to the tape punching means.

7 Claims, 32 Drawing Figures

					0	0	0	0	1	1	1	1
					0	0	1	1	0	0	1	1
					0	1	0	1	0	1	0	1
$b_7, b_6, b_5, b_4, b_3, b_2, b_1$					0	1	2	3	4	5	6	7
0 0 0 0 0	0	NUL	(TC) ₁ DLE	SP	0	@	P					p
0 0 0 1 1	1	(TC) ₁ SOH	DC ₁	!	1	A	Q	a	q			
0 0 1 0 2	2	(TC) ₂ STX	DC ₂	"	2	B	R	b	r			
0 0 1 1 3	3	(TC) ₃ ETX	DC ₃	#	3	C	S	c	s			
0 1 0 0 4	4	(TC) ₄ EOT	DC ₄	\$	4	D	T	d	t			
0 1 0 1 5	5	(TC) ₅ ENQ	(TC) ₅ NACK	%	5	E	U	e	u			
0 1 1 0 6	6	(TC) ₆ JACK	(TC) ₆ SYN	&	6	F	V	f	v			
0 1 1 1 7	7	BEL	(TC) ₇ ETB	'	7	G	W	g	w			
1 0 0 0 8	8	FE ₁ (BS)	CAN	(8	H	X	h	x			
1 0 0 1 9	9	FE ₁ (HT)	EM)	9	I	Y	i	y			
1 0 1 0 10	10	FE ₂ (LF)	SUB	*	:	J	Z	j	z			
1 0 1 1 11	11	FE ₂ (VT)	ESC	+	;	K	{	k				
1 1 0 0 12	12	FE ₃ (FF)	IS ₁ (FS)	.	<	L	¥	l				
1 1 0 1 13	13	FE ₃ (CR)	IS ₂ (GS)	-	=	M	}	m				
1 1 1 0 14	14	SO	IS ₃ (RS)	.	>	N	^	n				
1 1 1 1 15	15	SI	IS ₄ (IS)	.	~	O	~	o				

FIG. 7

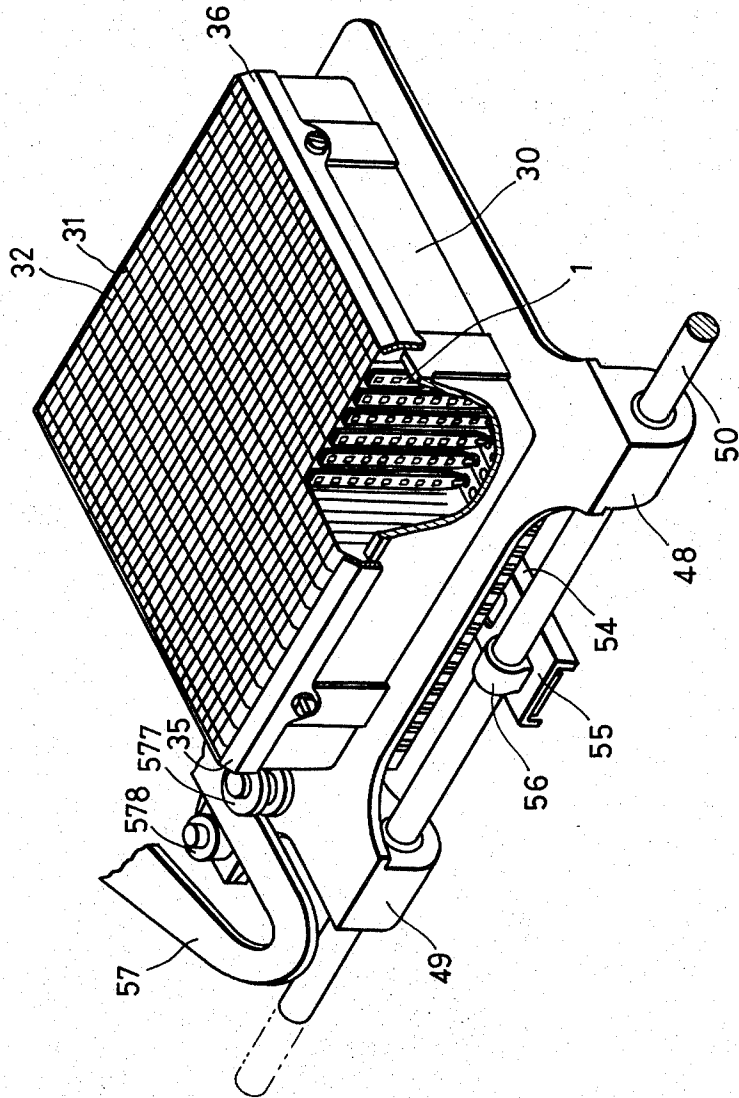

FIG. 5

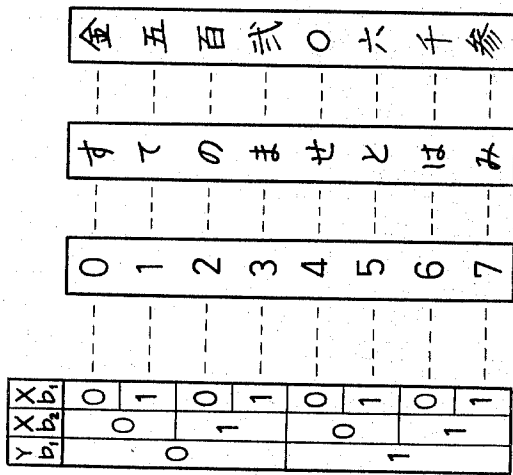

FIG. 6

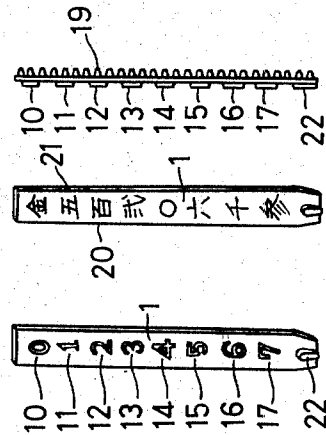

FIG. 9

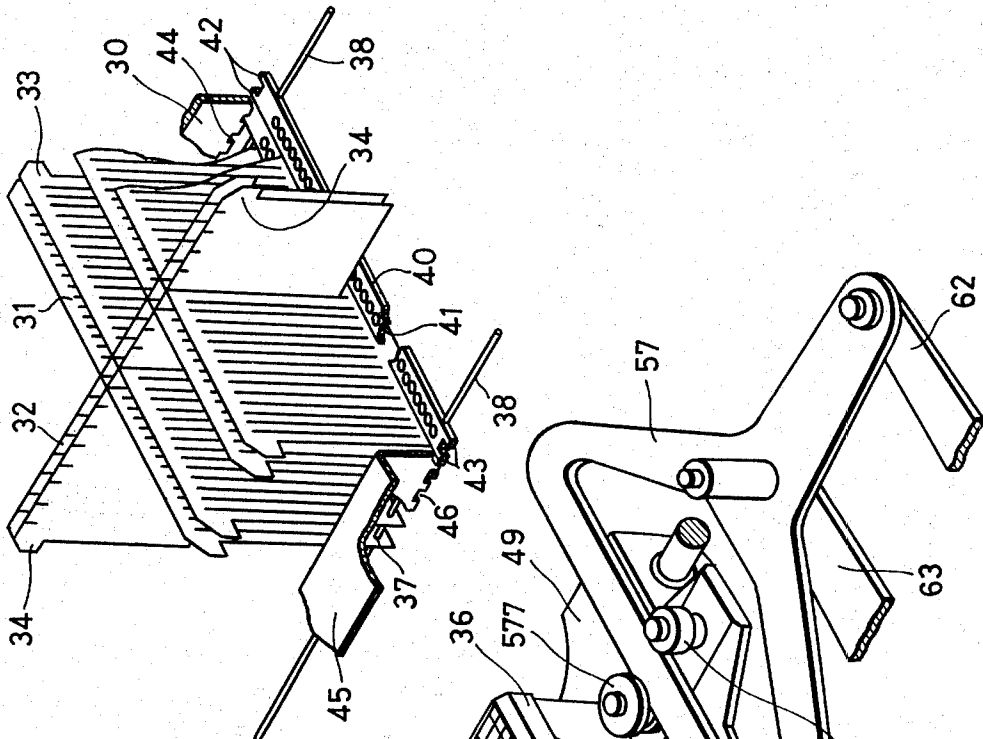

FIG. 8

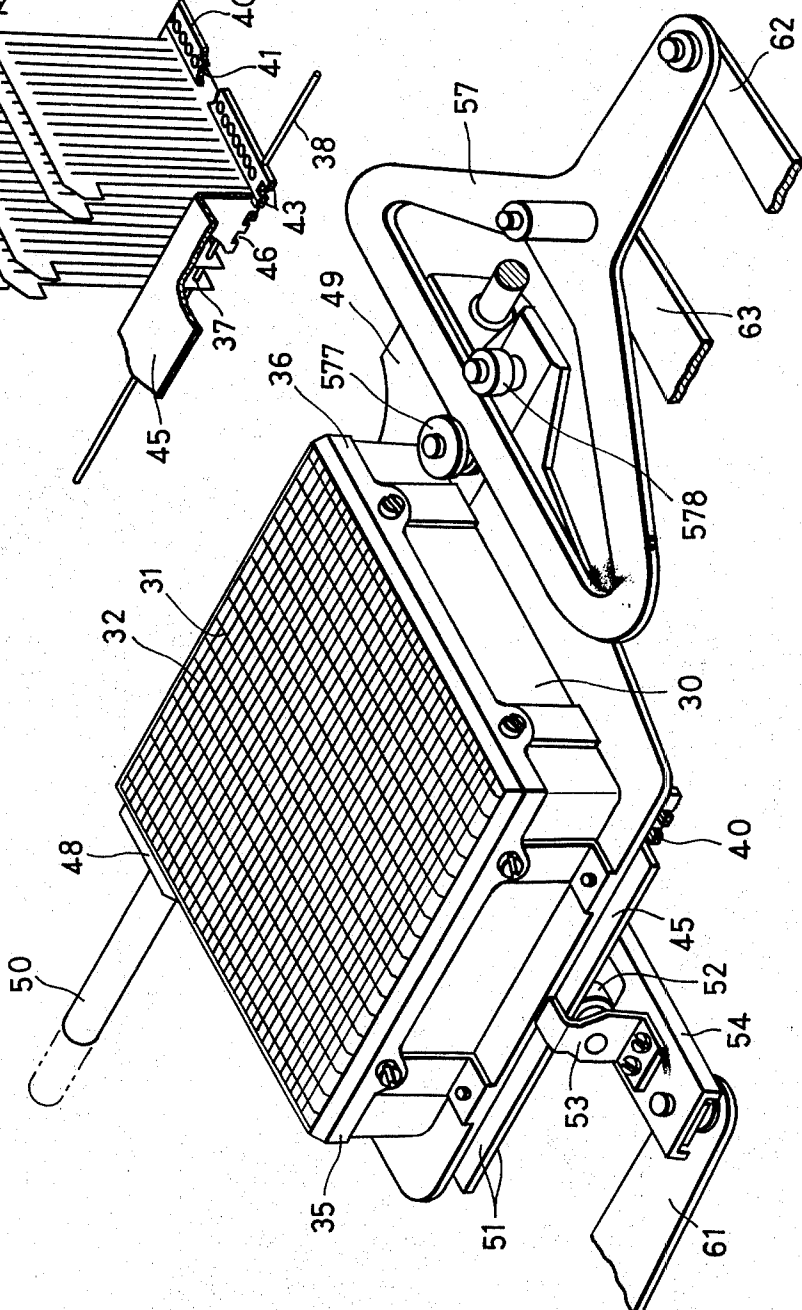

FIG. 10

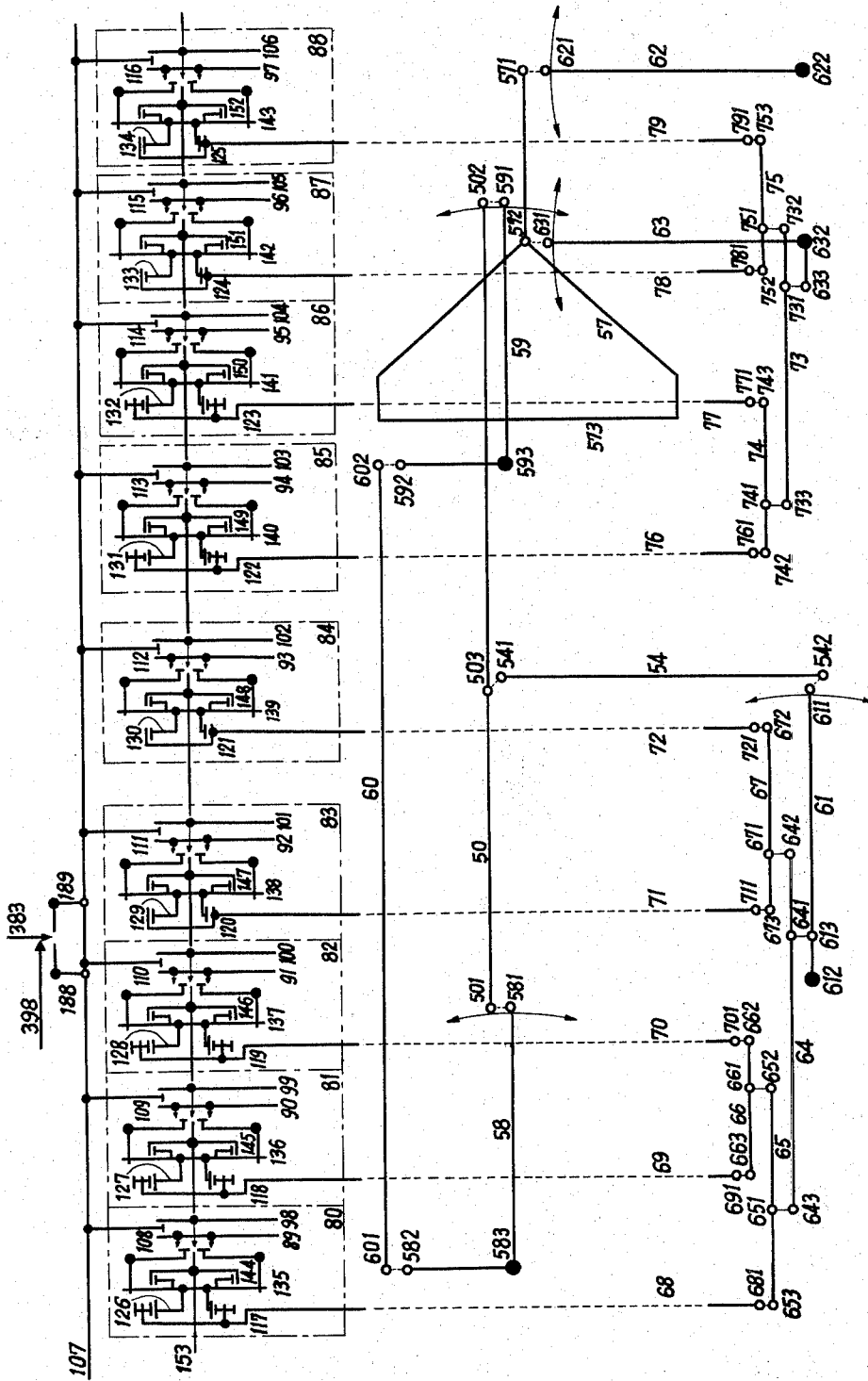

FIG. 11

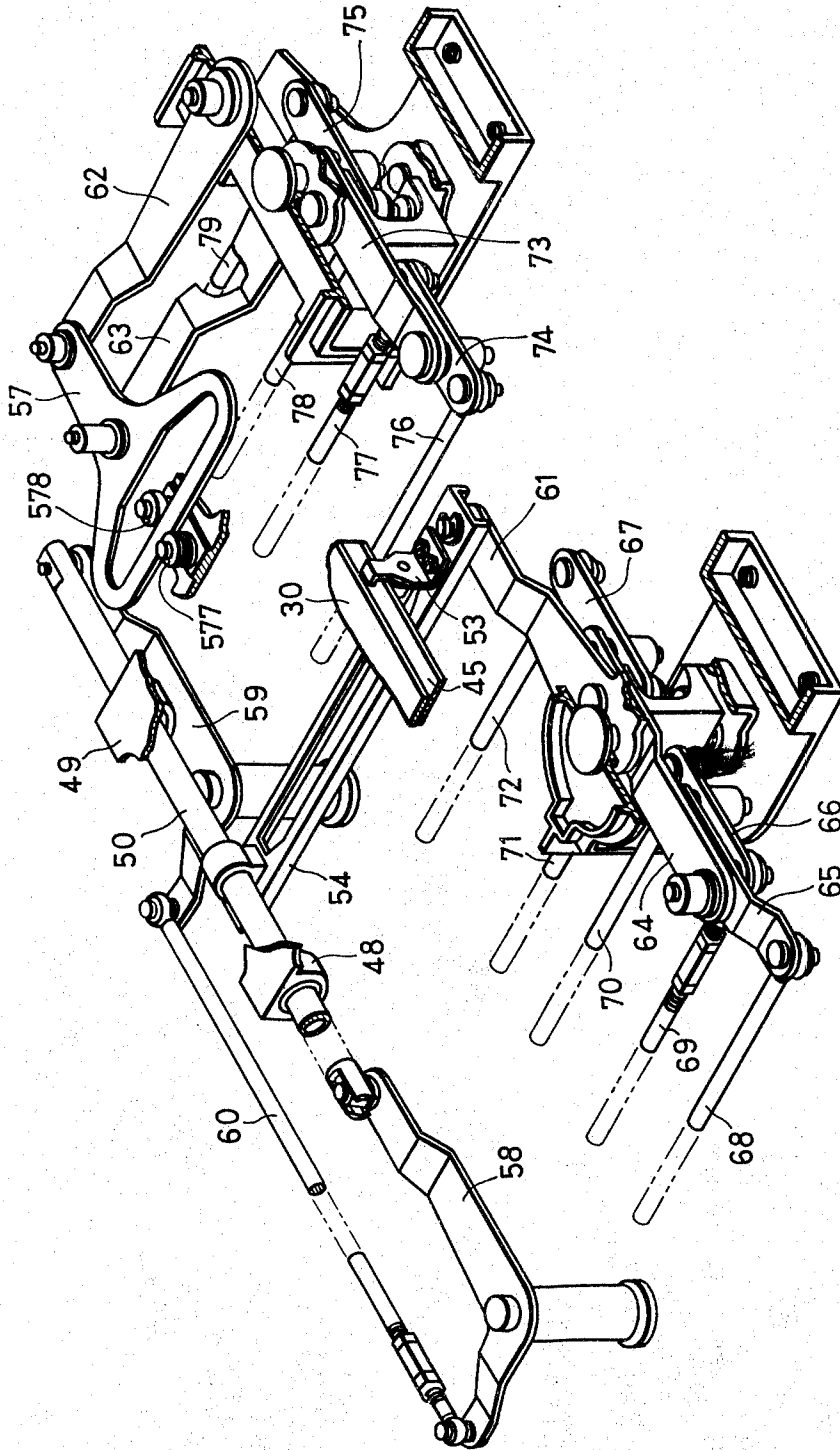

FIG. 12

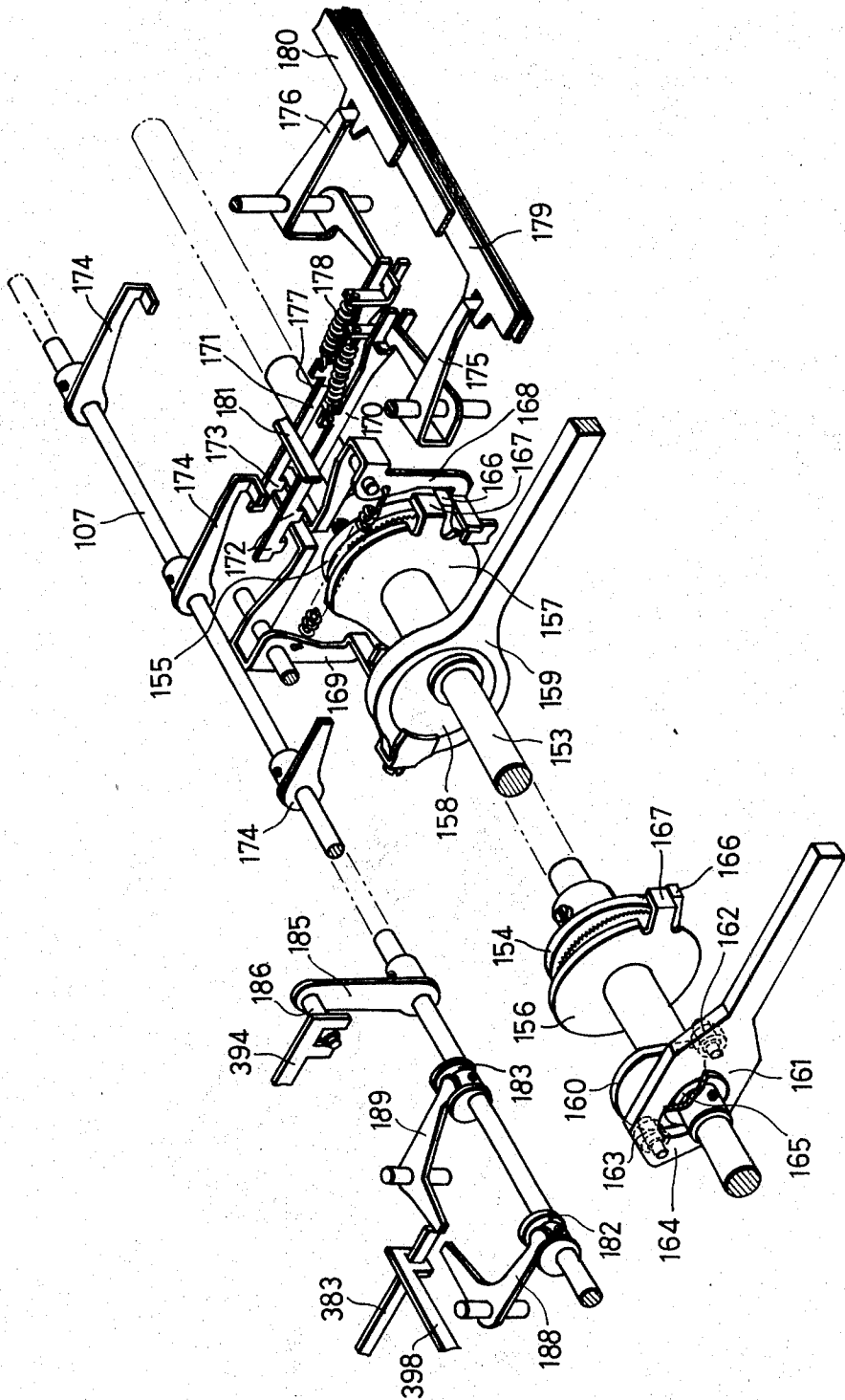

FIG. 13

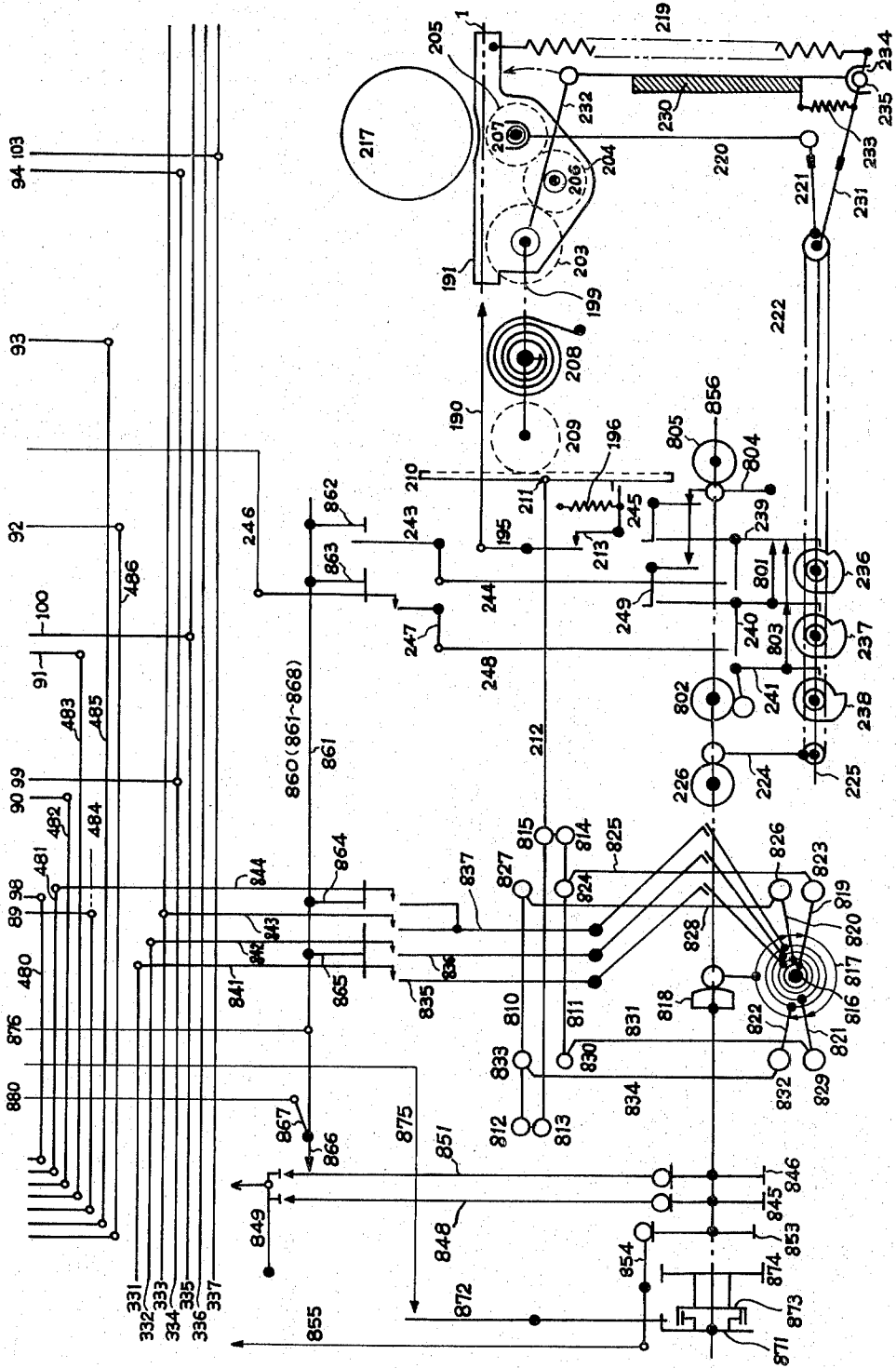

FIG. 14

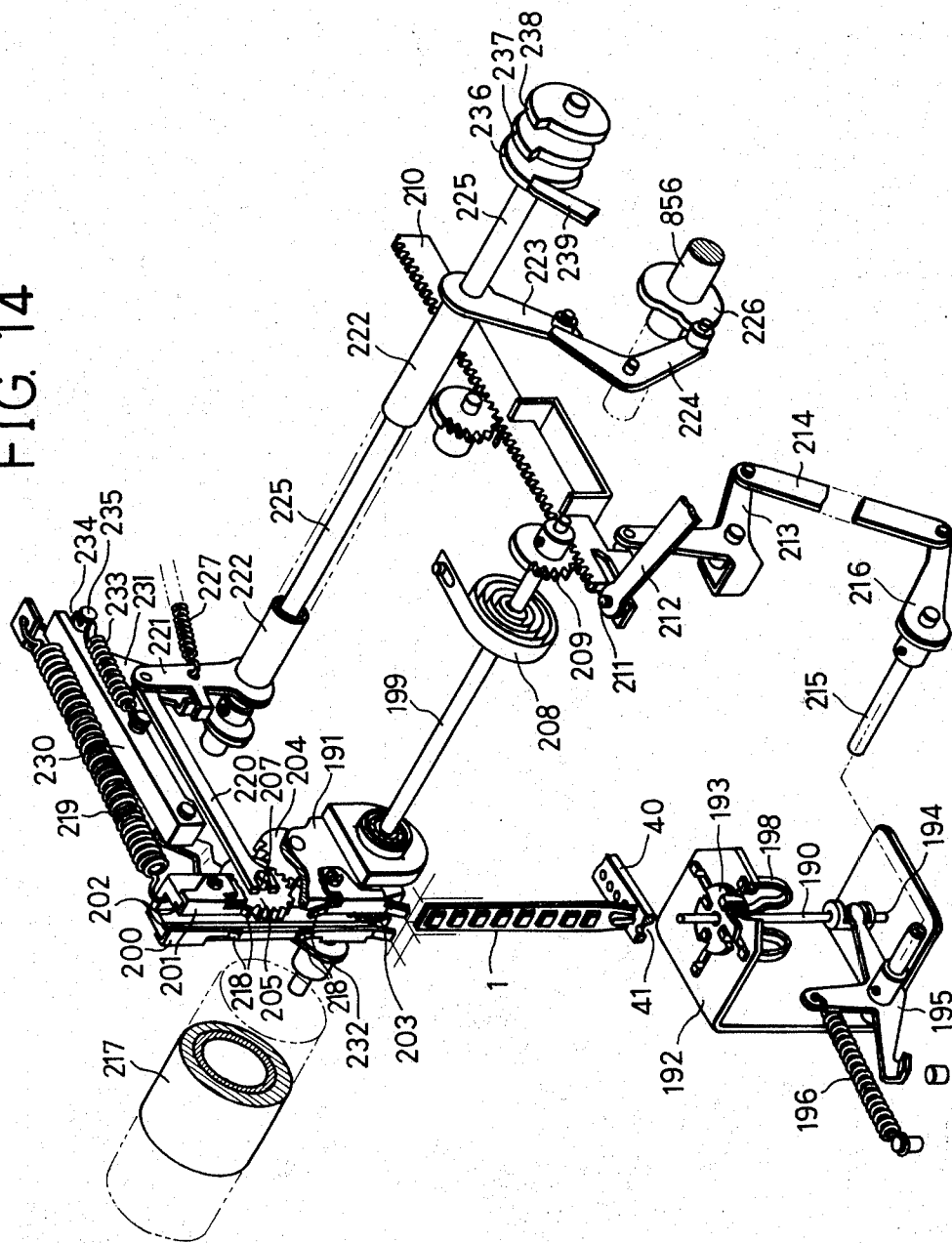

FIG. 16

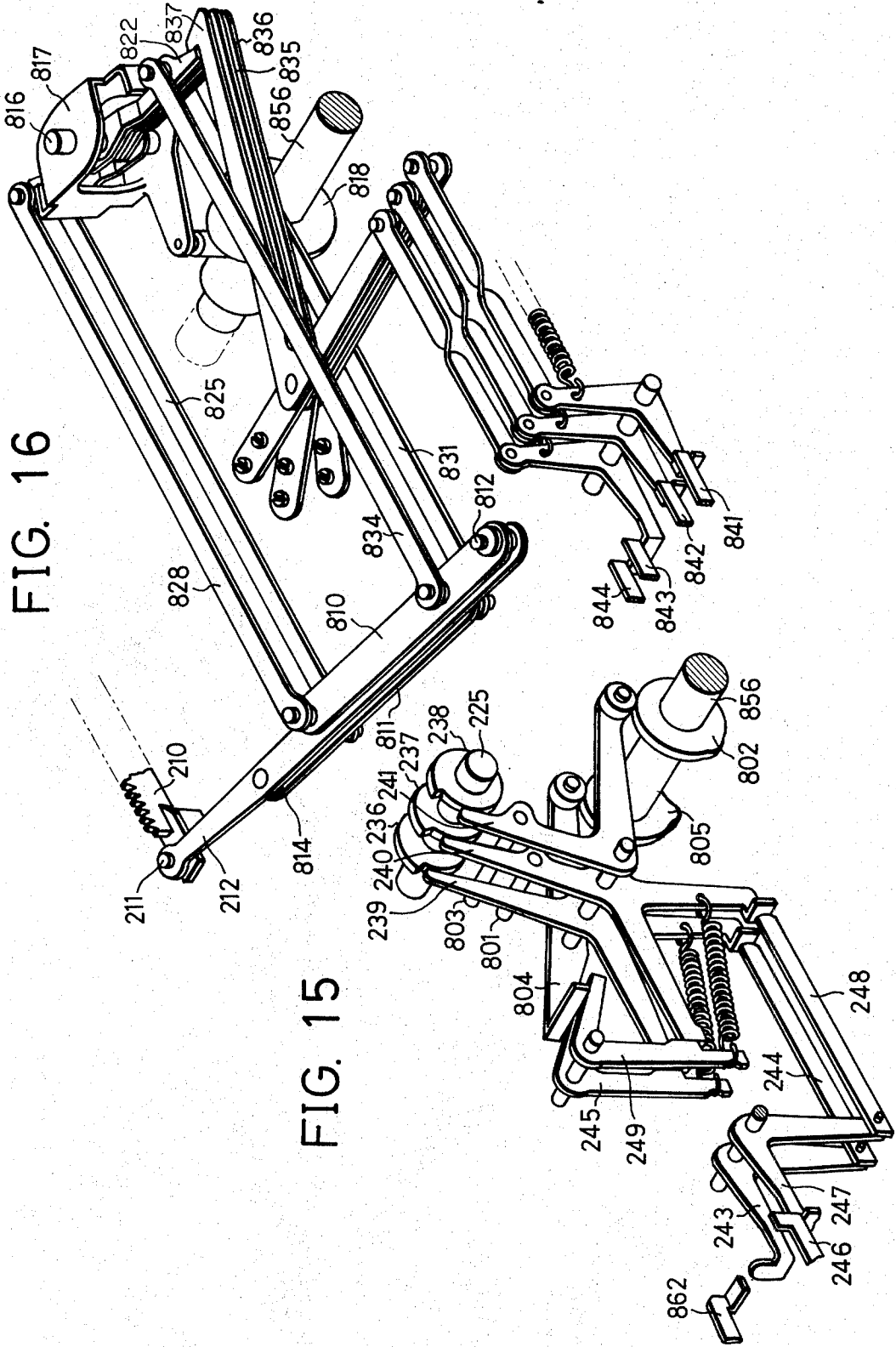

FIG. 15

FIG. 17

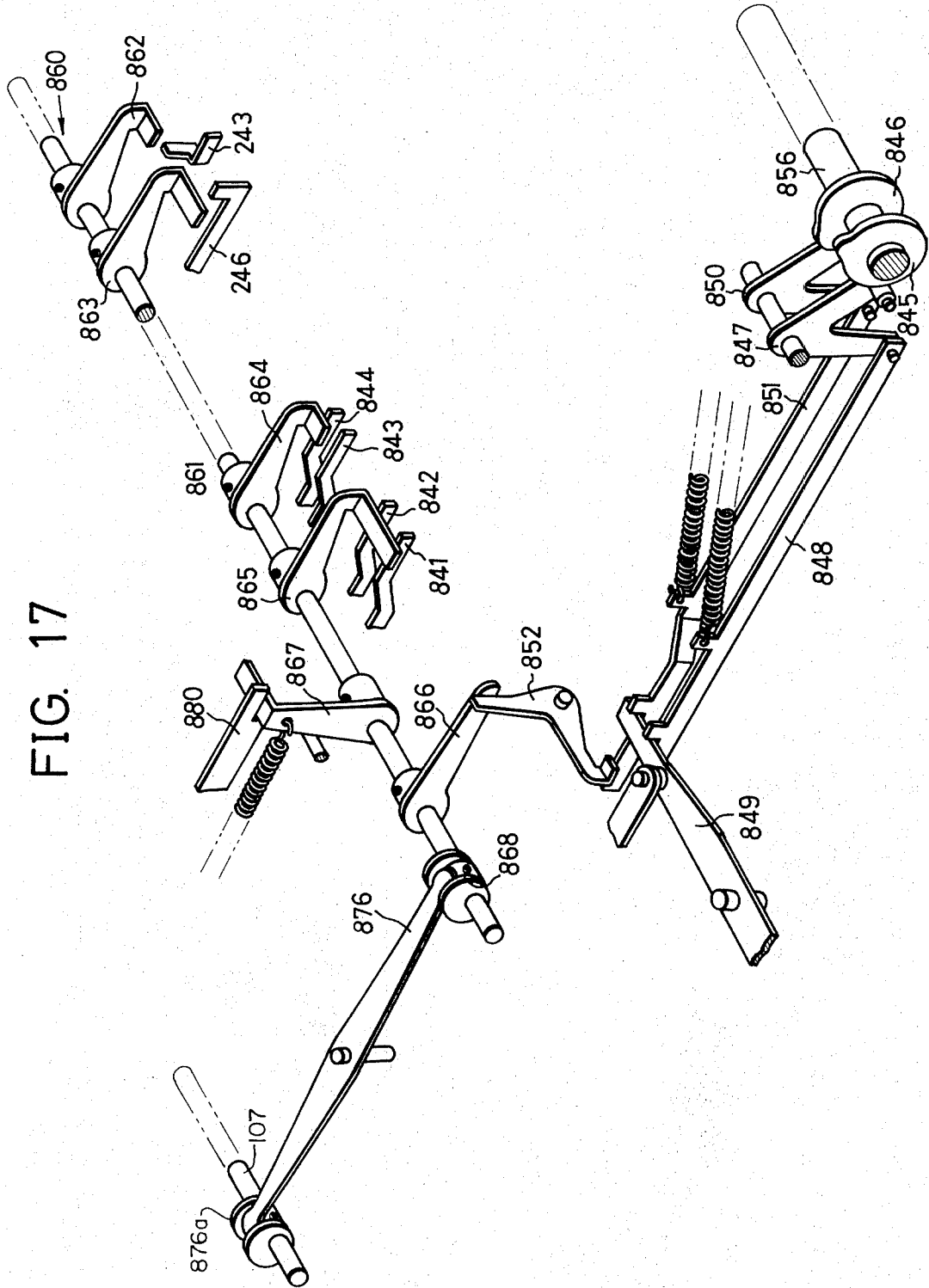

FIG. 18

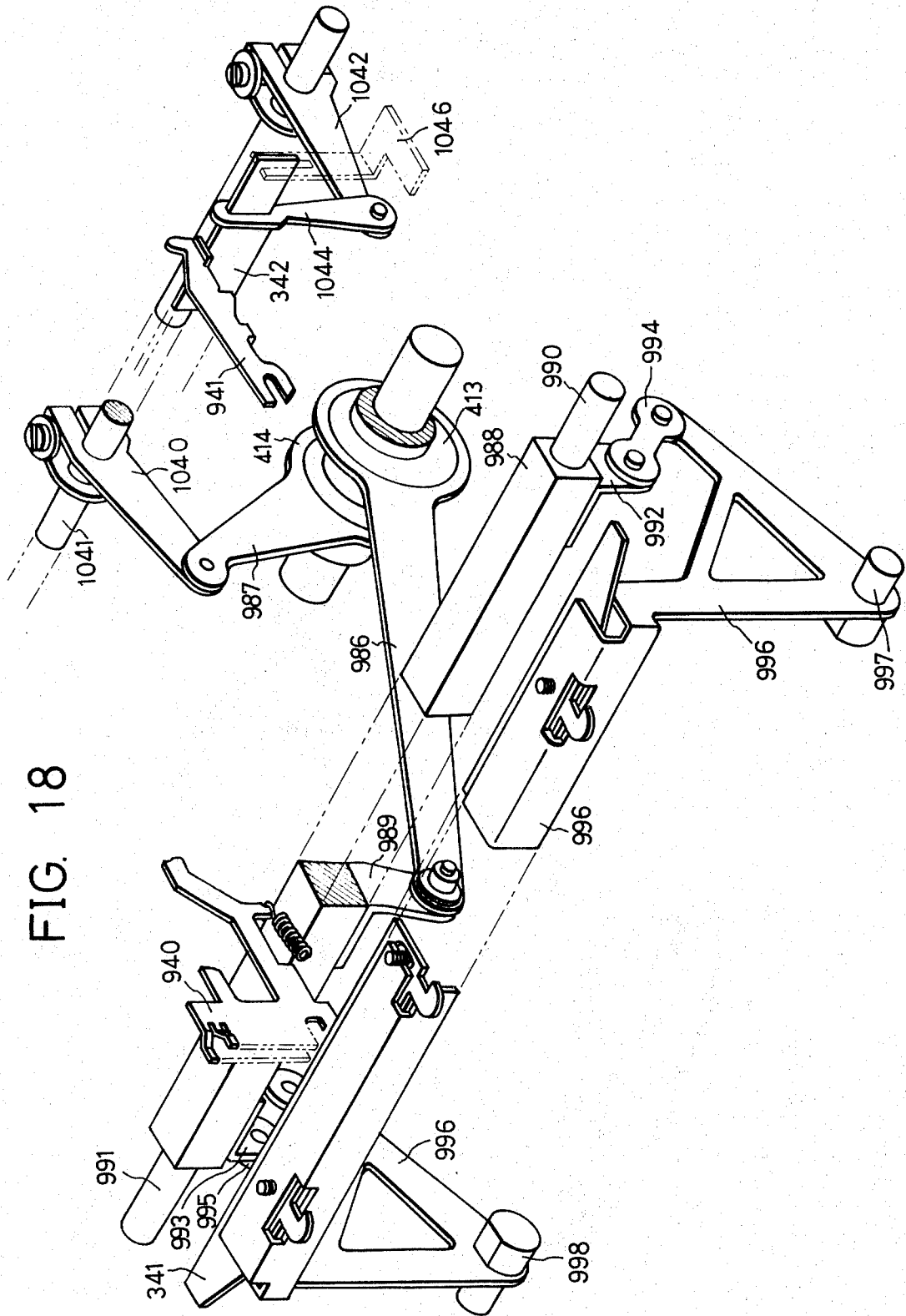

FIG. 19

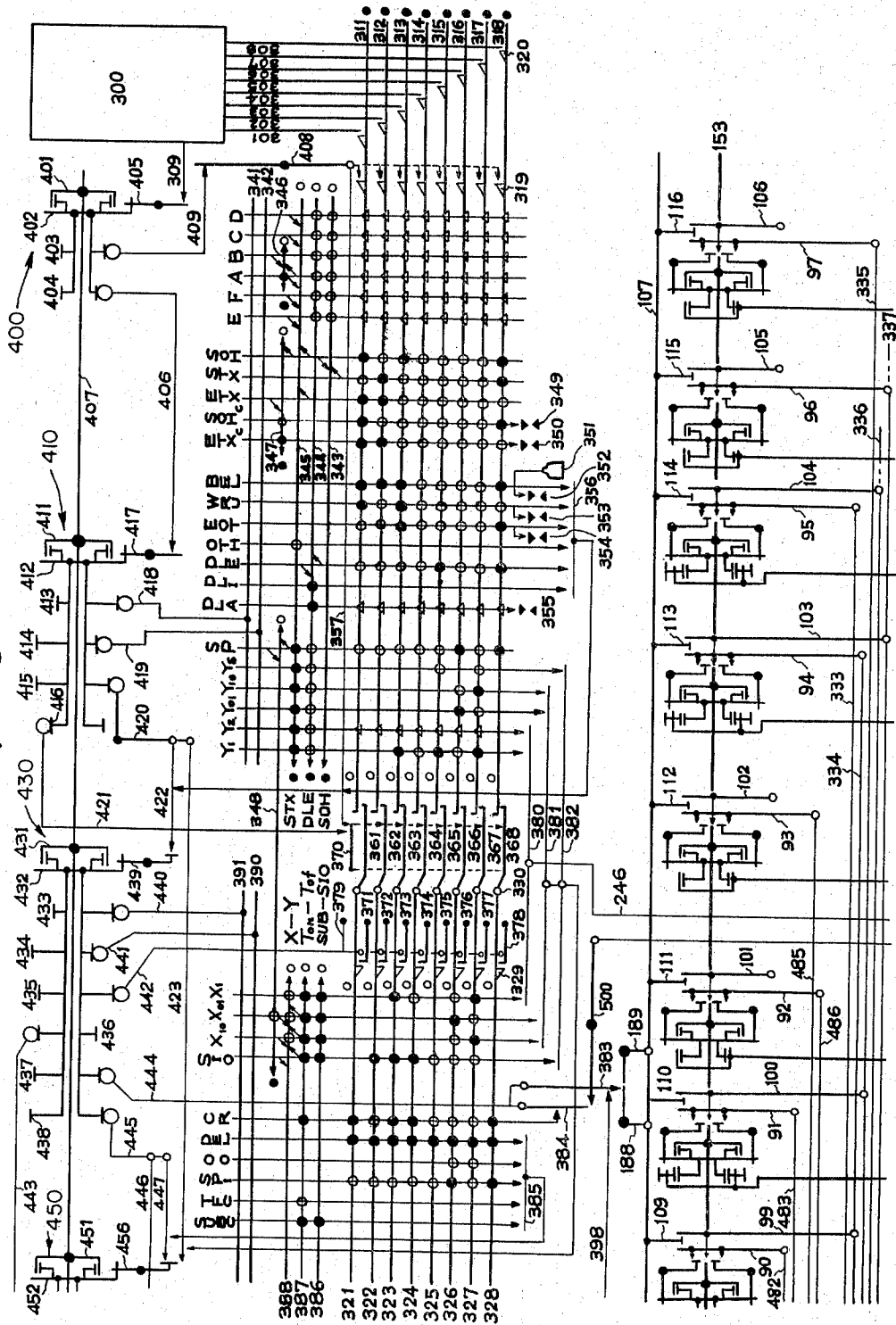

FIG. 20

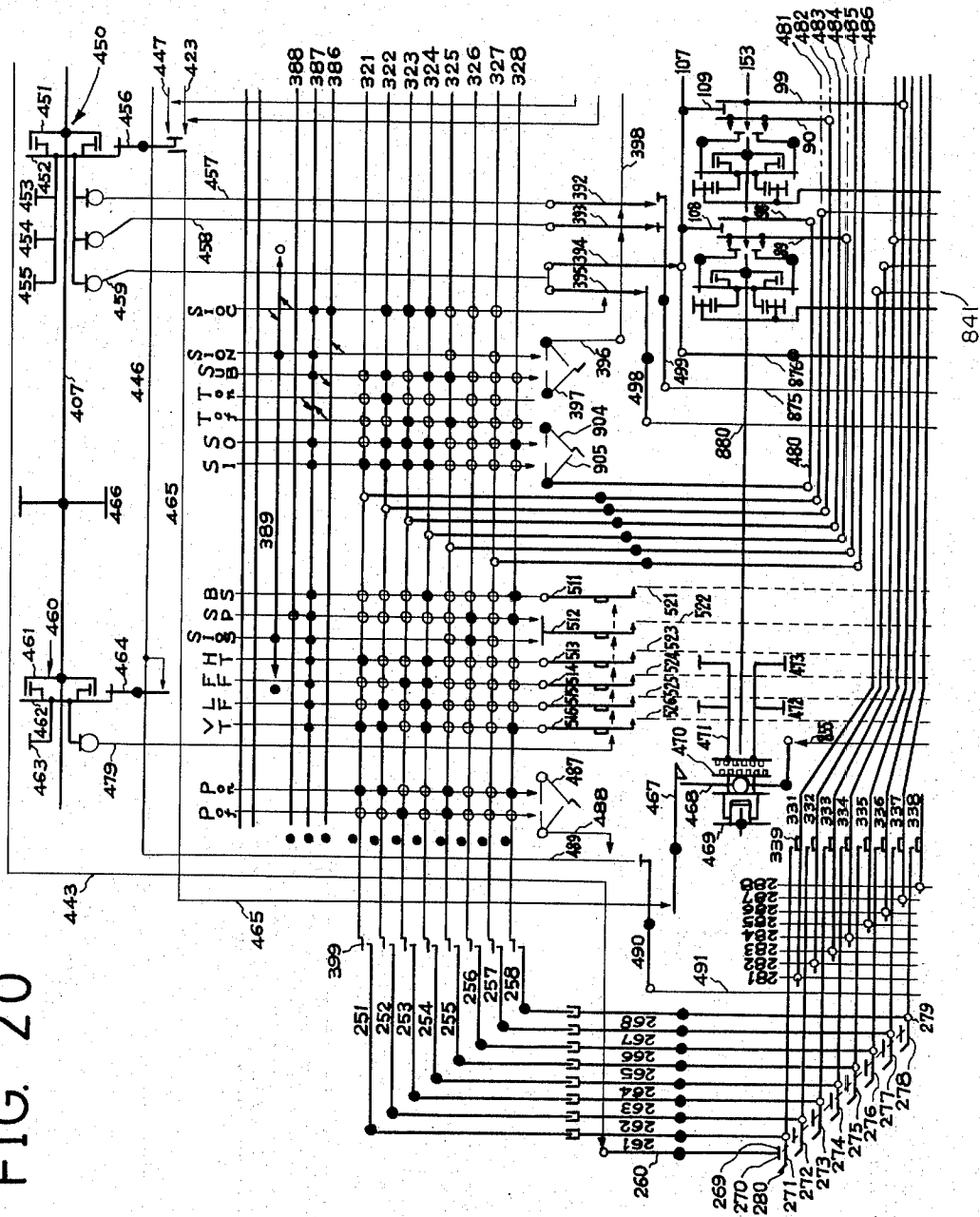
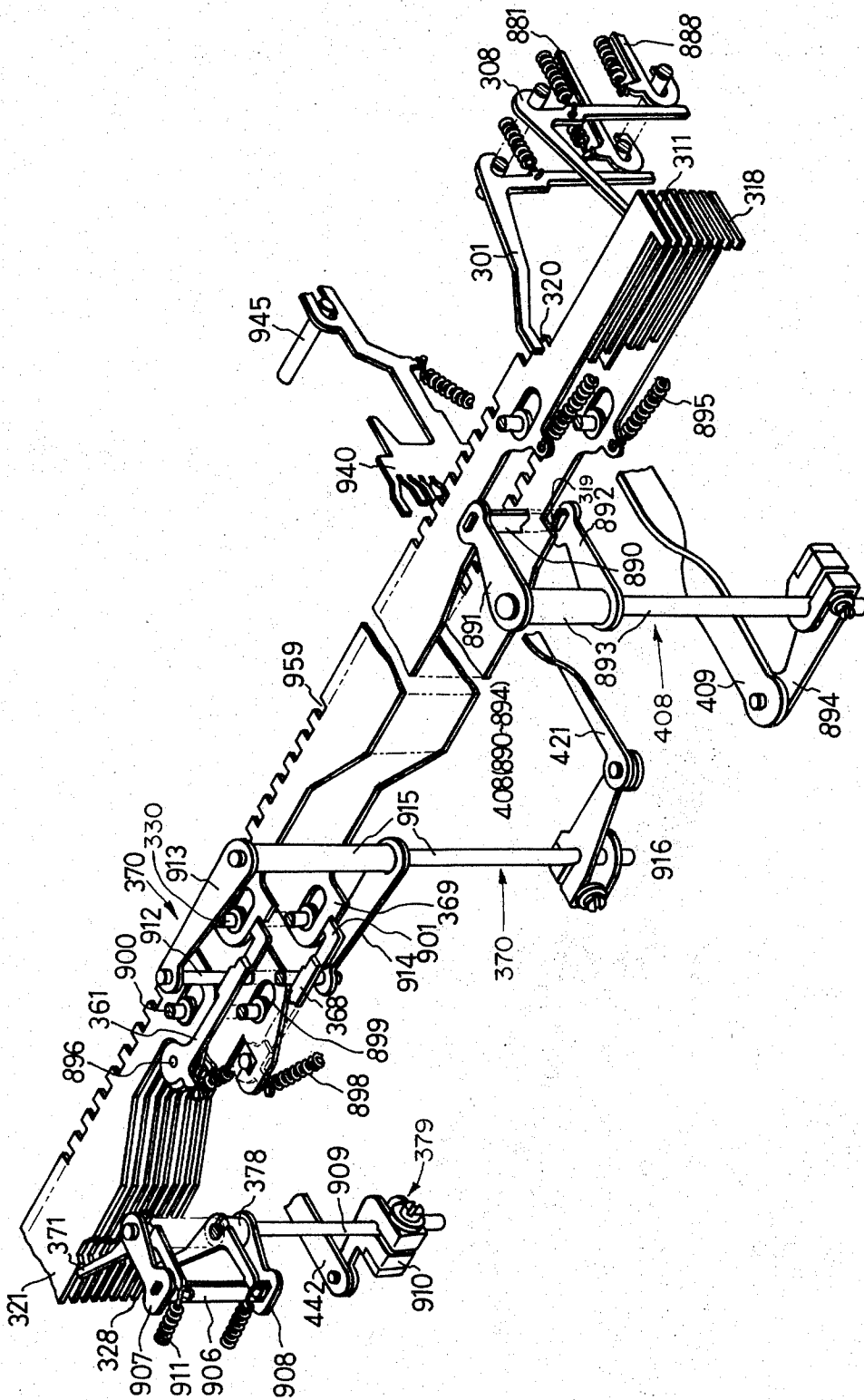

FIG. 21



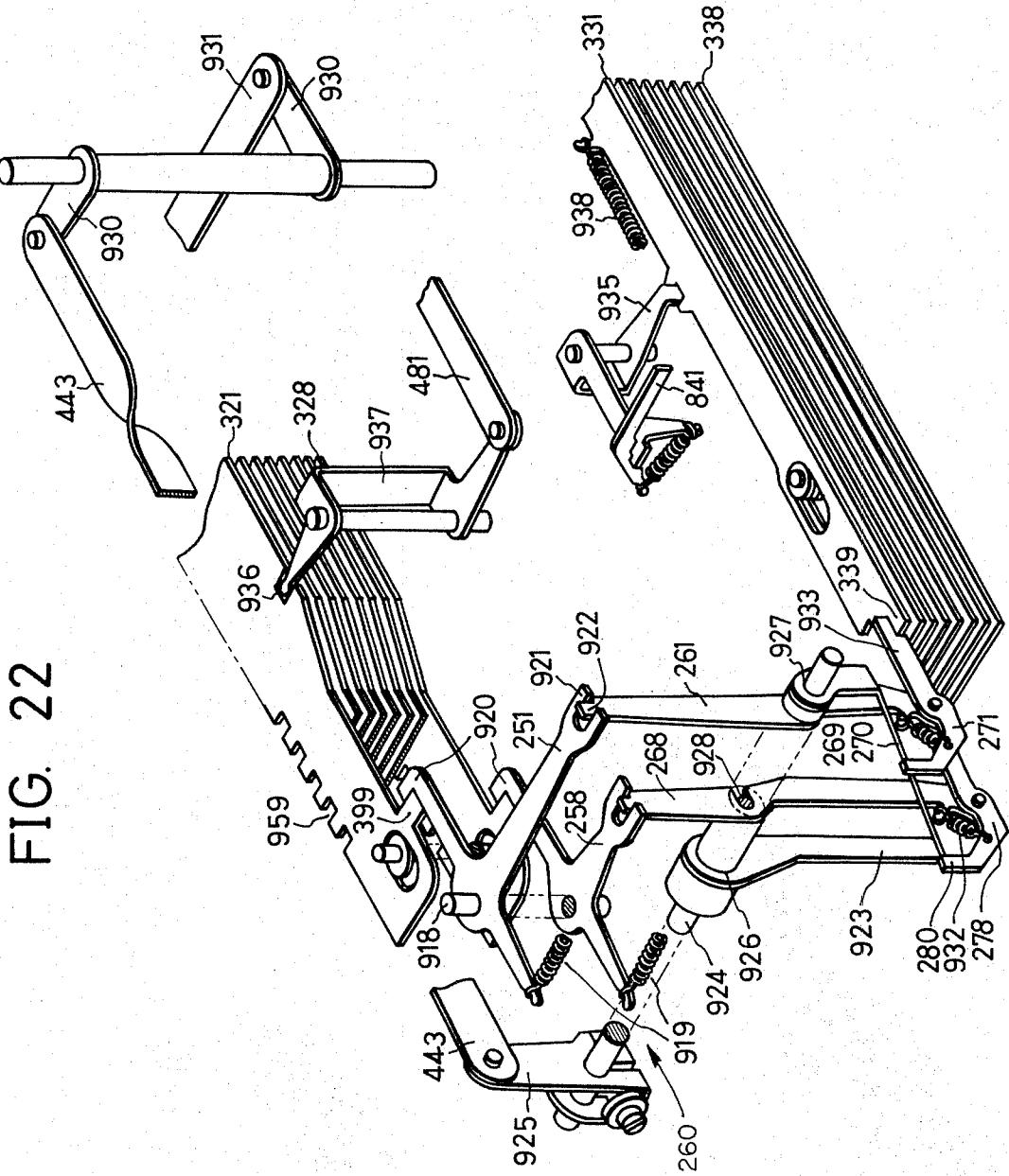

FIG. 24

FIG. 23

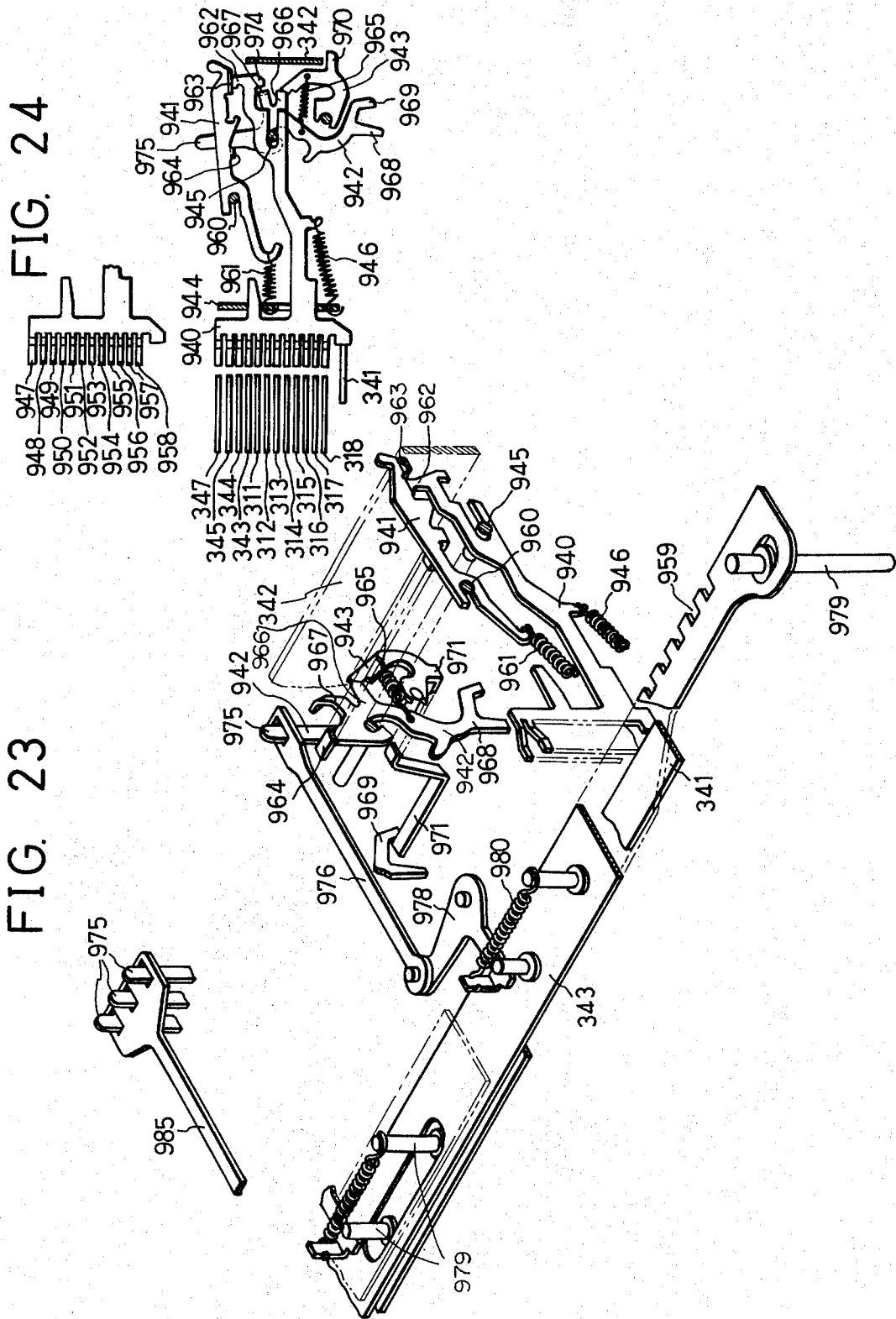

FIG. 26

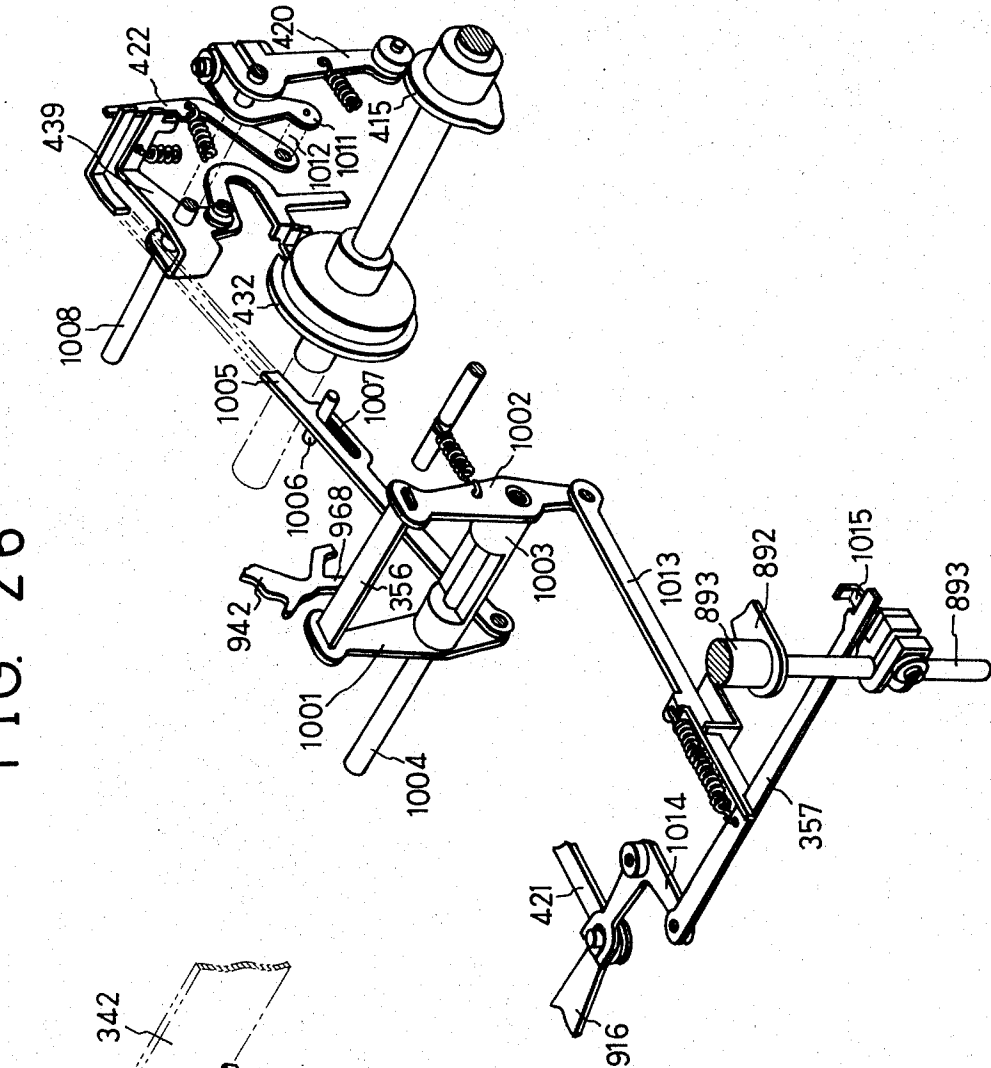

FIG. 25

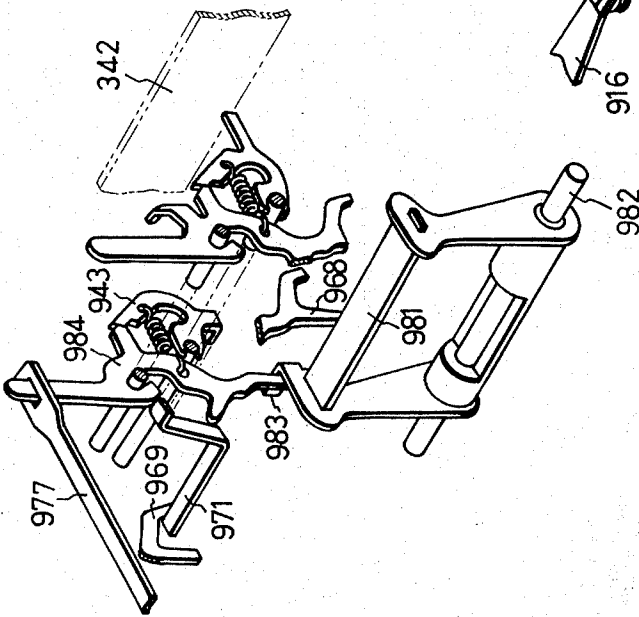

FIG. 27

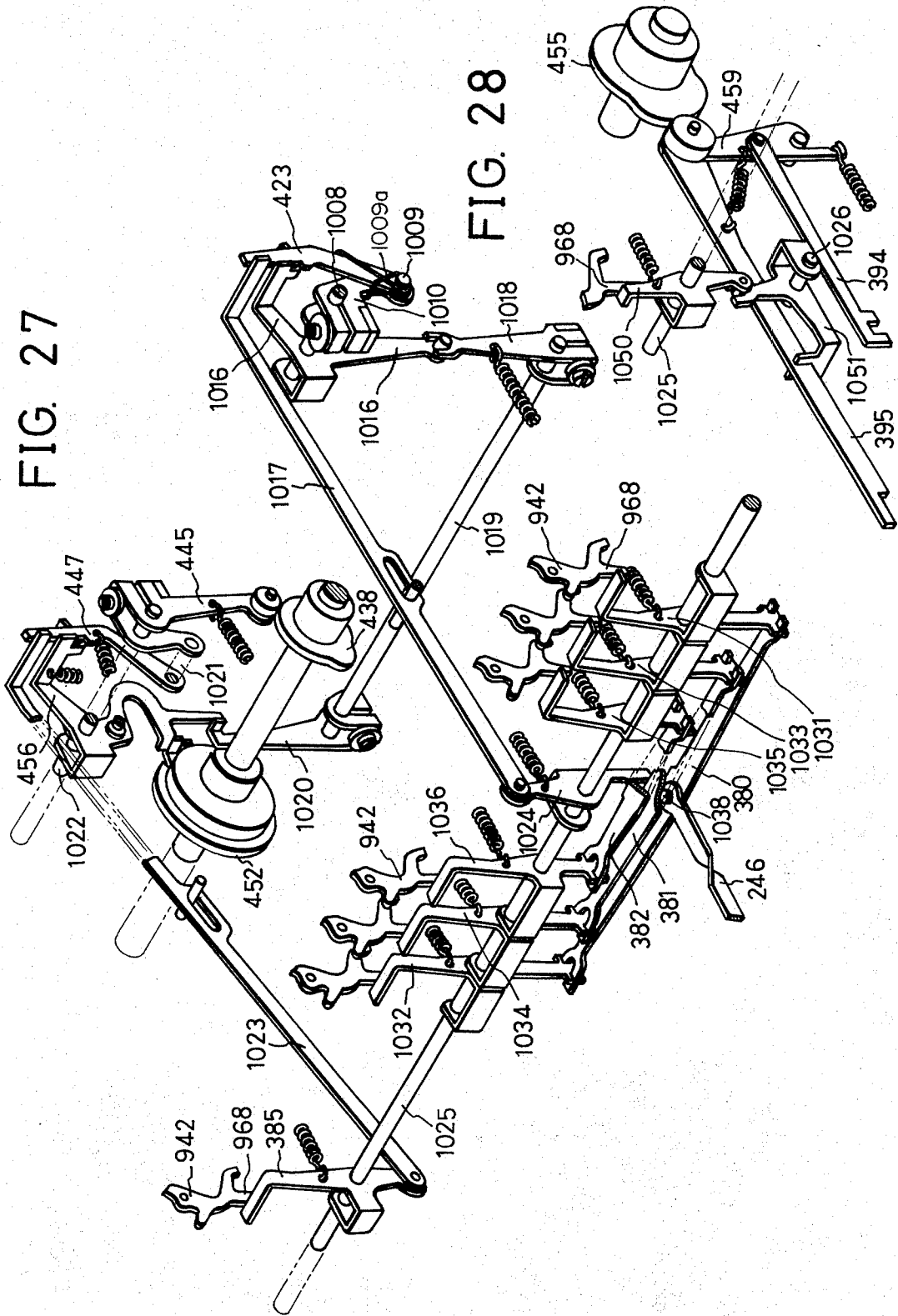

FIG. 28

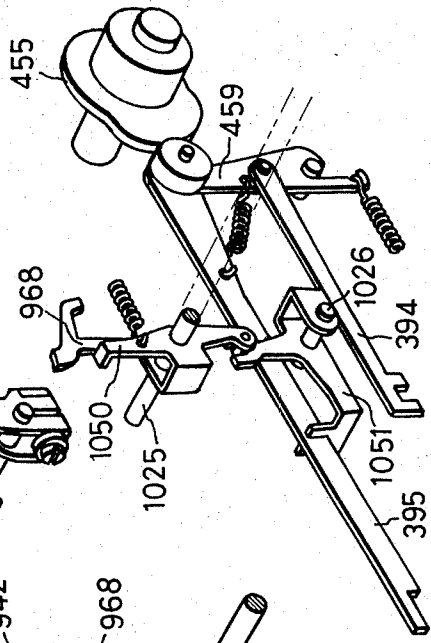

FIG. 29

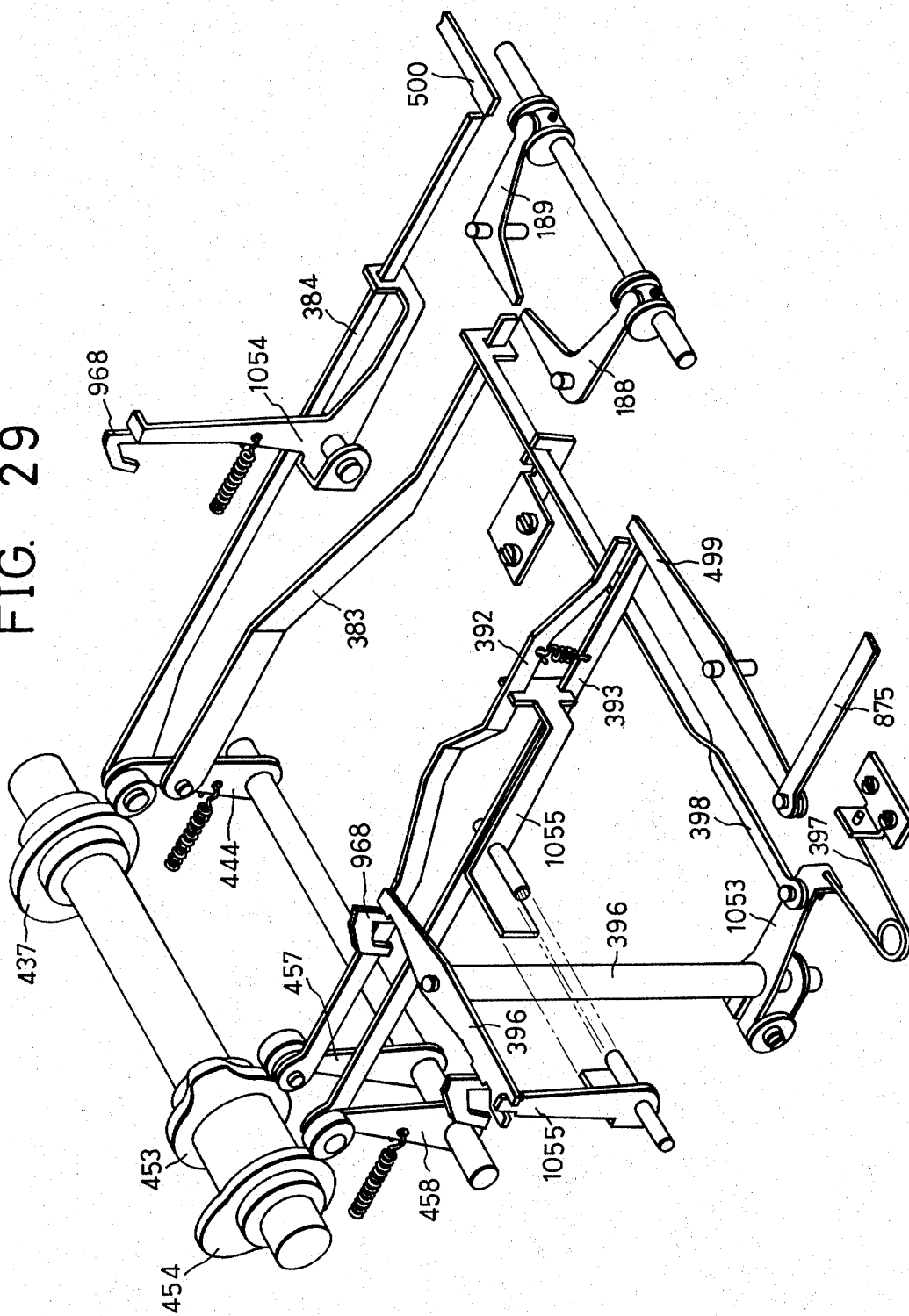

FIG. 30

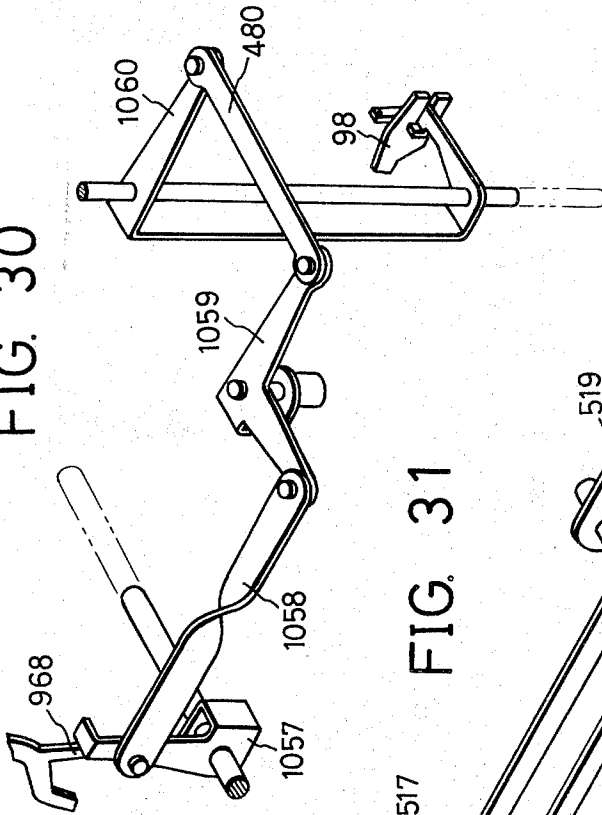
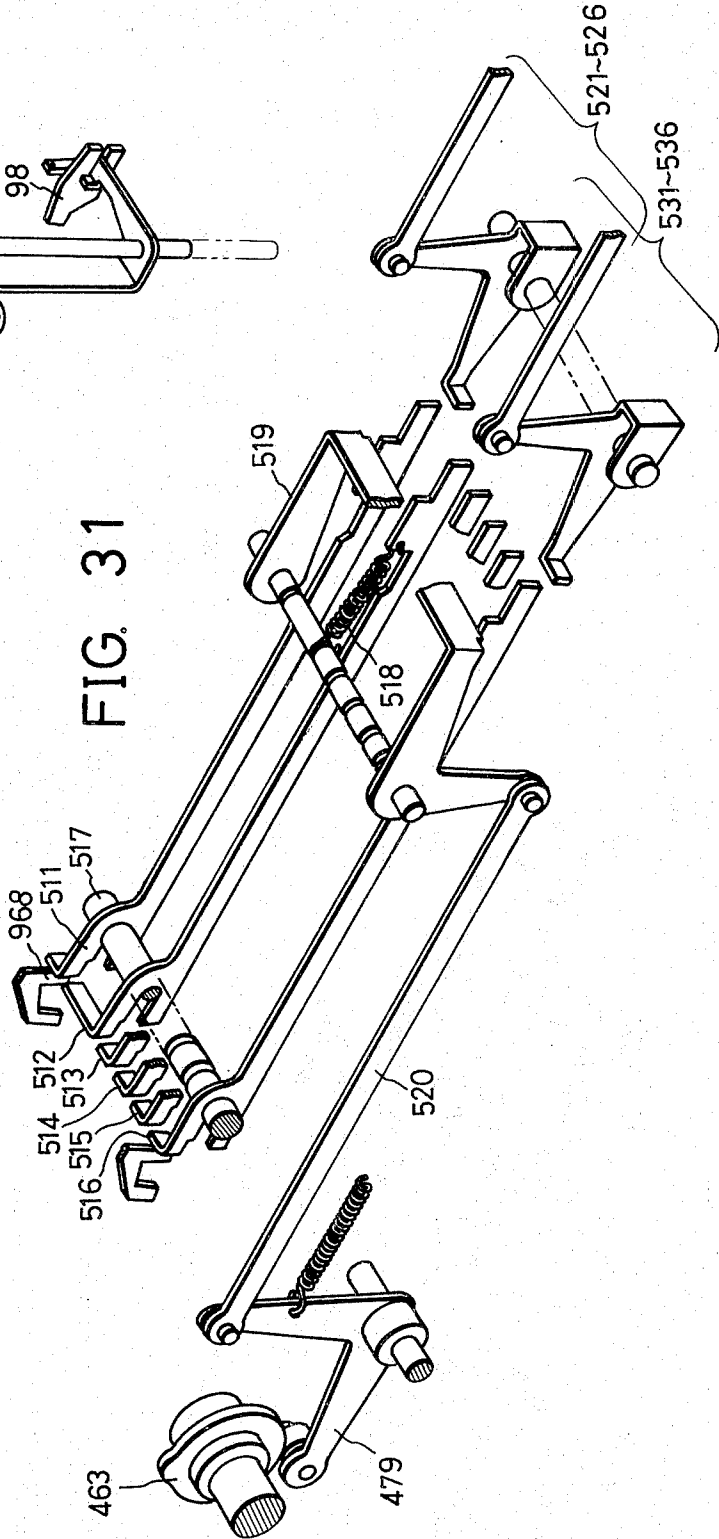

FIG. 31



CHINESE CHARACTER (KANJI) TELEPRINTER OR A CHINESE CHARACTER (KANJI) PUNCHING TYPEWRITER OR SIMILAR APPARATUS

OBJECTS AND BRIEF DESCRIPTION OF THE INVENTION

The invention relates to a new type of Kanji teleprinter and Kanji typewriter or similar apparatus.

Heretofore, a single character in Kanji teleprinters and in similar equipment has usually been represented by two six-element or eight-element code units in order to represent in code units all of the Kanji characters, of which there are over 2,000. A control code unit for transmission or a function code unit for form control or for auxiliary equipment control may be represented by a single code unit or by a combination of two code units, depending on the system involved; however, the use of a combination of two six-element code units or two eight-element code units to represent a character is the most common practice.

Kanji teleprinters and Kanji punch typewriters that require a system in which one character is represented by two six-element code units or eight-element code units are not convenient for terminal or peripheral equipment which is to be linked with a computer which constitutes the principal part of an information system. The input and output data of most of the currently available electronic computers and the control programs are in the form of single five-, six- or eight-element code units for Roman alphabet characters, symbols, and Katakana characters. When a shift code is used, the number of units is that determined by the state of shift. Moreover, a seven-element code unit has been established by CCITT as the International Information Exchange Code for use in information exchange, and this becomes an eight-element code unit by including a parity bit. The general trend is that said new information exchange code will be used for electronic computers, data transmission circuits, and terminal equipment of information systems of all the countries of the world.

Within the computer, except for the code units for control programs and those which represent numerals for use in calculations, there is no relationship between what a code unit is and what character it represents, but rather each code unit is considered to be a single, independent code unit, and either one such code unit represents independently an alphabetical character, a symbol, or katakana character, or a combination of 2 such code units represent a Kanji or Hiragana character, and there is no indication that a code unit represents the name of an object, people, or place or the usual letters. This is also the same for data transmission circuits, and excluding the code units for transmission control, all code units are considered simply as code units without their identifying any form or meaning. Therefore, if Kanji teleprinters or Kanji tape punch typewriters are to be widely used by linking them with information systems, code units which relate to the control programs of electronic computers and the characters corresponding to the code units, code units which relate to calculations and the characters corresponding to the code units, and code units for control of transmission in data transmission circuits and the characters or functions corresponding to the code units should be capable of actuating equipment for reproducing the relationships between the code units and the

corresponding characters as defined by the aforementioned International Code for Information Exchange.

The first object of the invention is to provide a Kanji teleprinter or a Kanji tape punch typewriter provided with new functions which are not provided in the currently available Kanji teleprinters and the like. The second object of the invention is to provide a mechanically constructed, low cost Kanji teleprinter which can be linked directly with a circuit so as to receive and to print the incoming codes.

The main feature of the invention is the establishment of a new function code unit to designate Kanji characters, and by the use of the new code unit as a third shift code unit (a code unit that changes the meaning of an alphabet or symbol character code unit) for an SI code unit and an SO code unit as defined by the aforementioned International Code for Information Exchange, the teleprinter or the like is caused to produce Kanji characters or code units for Kanji characters, and is caused to return to the normal operation by a further shift code unit. For Kanji character code units, the code units are grouped into sets of two code units in a particular order and by the combination of the units, Kanji and many other characters can be represented and printed. In the normal operational state, each character code unit is for a character according to the condition established by the shift code unit. The function code units are for the same function and activity regardless of whether the operational state of the device is Kanji or normal. The spacing operation for printing operations when the device is in the Kanji operational state can be twice that in the normal operational state or can be the same as in the normal operational state, and when the spacing is twice that in the normal operational state, so as to accommodate two code units, it is possible to make the length of one printed line proportional to the number of characters and the number of spacing code units regardless of whether the operational state is Kanji or normal.

The function code unit designating the Kanji-state may be considered as a third shift code unit in so far as it changes the meaning of a character code unit; however, it is entirely different from the shift code unit in the hitherto available teleprinters which simply changes the character represented by each character code, and which at the most can be used to represent twice the number of the characters by using an SI code unit for one set and an SO code unit for the second set. That is, in the Kanji operational state of the device, a combination of two code units in a particular order represents a single character; so if the number of character code units is N , then $N \times N = N^2$ characters can be represented. This is an entirely new concept for use of a function code unit that has not been conceived hitherto.

One of the additional features of the invention is a new design for a type-bar and a means to provide a great number of type-bars and to make a selection of a type-bar from among the great number of type-bars provided. The newly designed type-bar is a vertically elongated, thin piece, and a rack is provided for raising the type-bar. On the front surface of the type-bar are a number of raised characters (for example eight) arranged in one column. Such type-bars are arranged according to the code vs. character correspondence in sections partitioned off in a type-bar case. Each section which contains type bars is provided with holes

through which a push member can be inserted into the case to push up a type-bar. The type-bar case is moved in accordance with a character code unit by means of a type-bar case movement mechanism which displaces the type-bar case in the forward and backward direction and in the leftward and rightward direction to a position which is determined by the code unit, and moves a type-bar which corresponds to a character to be printed to a position above the type-bar case and opposite means which performs the printing action.

A second additional feature of the invention is a means for transferring by selective movement of the type-bar case, the selected type-bar so that it is placed adjacent to the printing action means and bringing it into printing position opposite the printing action means by raising the type bar so that the character corresponding to the code unit is in a printing position with respect to a platen, and a means to perform the auxiliary operations and to cause the printing action means actually to perform a printing operation. This means comprises a push-up mechanism under the type-bar case which pushes up the selected type-bar; a member in the printing active part for actuating the type-bar for printing; a series of gears which raise and lower the selected type-bar by engaging with the rack which is on the back surface of the type-bar; and a type raising mechanism which controls the amount of rise of the type-bar a certain distance according to the character code unit, and transmits the corresponding amount of rise to the series of gears; and a print driving mechanism which keeps the printing action means generally away from the platen but makes the printing action means approach the platen, and after the rise of the type-bar, strike the back of the print action means to cause the type-bar to print on the platen.

The third feature of the invention is a means in the aforementioned printing device mechanism to change the striking energy transmitted to the printing action means by a special combination of code units or according to whether the device is in the Kanji operational state or the normal operational state.

The fourth feature of the invention is the provision of two memory selector mechanisms and a storage mechanism for performing auxiliary functions which will be described hereinafter. An incoming code unit, whether it is received from a transmission line and translated by a receiving selector mechanism before it enters the first memory selector mechanism or whether the code enters the first memory selector mechanism directly from a tape recorder or an electronic computer, or any other electric circuit is first handled by the first memory selector mechanism which identifies the control code units for transmission and auxiliary operations, and at the same time, prevents the transmission to the second selector mechanism of the code units unnecessary to operations beyond the second memory selector mechanism. When processing of the code unit in the first memory selector is complete, the incoming code is transferred to the second memory selector mechanism, and the first memory selector mechanism awaits the next code unit. When the incoming code is received by the second memory selector mechanism it is identified either as a code unit for controlling the operational state of the device, as a function control code unit or as a character code unit, an actuating signal to produce the action called for by the code unit is transmitted by the second memory selector mechanism to the appro-

appropriate mechanism. Among the code units for controlling the operational state, there is a code unit for the Kanji state, and a code unit for changing from the Kanji state to the normal state. Each such code unit is identified by the second memory selector mechanism which controls the apparatus so that it is in a state corresponding to the code unit. Function control code units are code units that control the action of the printing mechanism, activation and deactivation of punching mechanisms and mechanisms that control such actions as spacing, back spacing, carriage return, rotation or shifting of the platen, HT, VT, FF, and each code unit for such functions is identified, and the appropriate mechanism is actuated. In the normal operational state, a single character code unit represents one character, and as soon as a character code unit is identified by the second memory selector mechanism, the type selecting and printing mechanism is started. When the apparatus is in the Kanji operational state the second memory selector mechanism distinguishes the first code unit from the second code unit of the two code units that represent one character, and the command to start the type selecting and printing mechanism is given only when the second of the code units arrives at the second memory selector mechanism and is identified.

When the identification of the code unit and appropriate action in the second memory selector mechanism is complete, the incoming code unit is transferred to the memory mechanism, and the second memory selector mechanism awaits the next code unit. The transmittal of a code unit to the type selecting printing mechanism is performed, when the apparatus is in the normal operational state, by said storage mechanism and when the apparatus is in the Kanji operational state by the storage mechanism and the second memory selector mechanism. A code unit that has been transferred to the storage mechanism will be cleared when appropriate action is completed and the next code unit arrives from the second memory selector mechanism.

The fifth feature of the invention relates to the speed of printing. Since the time for carrying out printing when one character code unit for one character is received with the apparatus in the normal operational state is less than the time for two character code units when the apparatus is in the Kanji operational state, type-bars used in the normal operational state can be collected in one part of the type-bar case to minimize the amount of movement of the case in the forward and backward direction and in the leftward and rightward direction. For the same reason, the arrangement of the code units for the Kanji characters and the normal characters must be different in order to transmit the code units to the selecting drive mechanism for movement of the case in the forward and backward direction and leftward and rightward direction of the type-bar case. There are thus two means for transmitting character code units from the storage mechanism and the second memory selector mechanism to the type selecting printing mechanism and which switch over between the normal operational state and the Kanji operational state. Also the drive mechanism for carrying out the movements of the type-bar case in the forward and backward direction and in the leftward and rightward direction is such that the speed of action when the apparatus is in the normal operational state is much faster than the speed of action when the apparatus is in the

Kanji operational state in which one printing action takes place during the time required to handle two units as compared to the normal operational state in which one printing action takes place in the time required to handle only one code unit.

As a result of the present invention, when the aforementioned International Code for Information Interchange (henceforth referred to as the ISO code) is used, a Kanji teleprinter or Kanji tape punch typewriter which has many Kanji characters can be linked with an electronic computer or a data transmitting circuit which uses Roman alphabet characters, symbols, and Katakana characters for control and calculations. In connection with the linking of the Kanji teleprinter of the invention to an electronic computer, the problem which must be considered on the computer side is the treatment of the function code unit which establishes the Kanji operational state which is included in the input and output information. The function code unit can be a character code unit as such or can be a code unit which has not been used for any other character, and can be returned to the original state at the time of its output. In a case like a slip having a column of fixed form for characters expressible in the Kanji form, said problem can be resolved at the time of output by automatically inserting the function code in accordance with the form. In any case, the character code units which represent a great number of Kanji characters also represent Roman alphabet characters and symbols, and the character code units which represent Katakana characters will not be treated differently from any other code units but simply as a character code unit in the electronic computer.

A second result of the invention is that the Kanji teleprinter or the tape punch typewriter of this invention can be linked, when the ISO code is used, with an ordinary teleprinter or tape punch typewriter which processes only symbols and Katakana. Accordingly, if the ordinary teleprinter or tape punch typewriter can transmit the function code that designates the Kanji operational state, many code units for Kanji can be produced by combinations of code units for Roman alphabet characters, symbols and Katakana characters.

Among the characters which can be represented in Kanji form are not only Hiragana but also Katakana characters. Moreover, sonant characters can also be represented. It is thus conceivable that henceforth Katakana characters need not be used in teleprinters. In such case, if the Kanji operational state is indicated by an SO code unit, many characters which can be represented in Kanji form will correspond to a combination of two Katakana characters in an electronic computer and on an ordinary teleprinter or tape punch typewriter, and the linking of a Kanji teleprinter or a Kanji tape punch typewriter according to the invention to an information processing system can readily be made without requiring any special equipment.

One of the additional features of the invention is firstly, since the type for several characters are arranged on one type-bar, for example if type for eight characters is arranged on a single type-bar, the number of type-bars required will only be one-eighth the number of characters, and as a result not only can some steps in the fabrication of the apparatus can be eliminated but also the type-bar case can be made smaller and lighter so as to increase its mobility. If the maximum number of characters that can be represented by

combinations of 12 code elements, which is 4,096, is to be accommodated, the number of type-bars required will be 512, and if to accommodate a single type-bar, each section of the type-bar case has a dimension of 3 mm in the front to rear direction and 6 mm in the side to side direction, and there are 32 sections in the forward and backward direction and 16 sections in the leftward and rightward direction, the 512 type bars can be accommodated in a case which is about 100 mm × 100 mm, and the movements in the forward and the backward direction and the leftward and the side to side direction will both be about 100 mm. The type-bar case thus has a practical size. The rack on the back surface of the type-bars is used during the manufacture of the type-bars to accurately locate the positions of the type and so that the position of the type is accurate during operation of the apparatus.

A second additional feature of the invention is that because the width of the part of the apparatus that performs the printing is narrow, visual observation of the character printed on the platen is facilitated, and since the printing means is normally maintained at some distance from the platen, the last character printed can readily be observed visually.

A third additional feature of the invention is that the pressure with which the printing means strikes the platen can be regulated. In general the surface area of the type for Kanji characters and the surface area of the type for Roman alphabet characters is very different, so it is desirable that the printing pressure can be regulated. Also some of the characters and symbols, such as punctuation marks, used when the apparatus is in the Kanji operational state have small surface areas. In the apparatus of the invention, such symbols and the like with very small surface areas are collected on type bars in a location in the case and the location is identified by a code unit and in the Kanji operational state and in the normal operational state to regulate the printing pressure.

A fourth additional feature is that the use of a control code for transmission in the first memory selector mechanism becomes possible, and it is possible to use the Kanji teleprinter of the invention as terminal equipment in the control of an exchange center of a communication system. Said equipment is capable of identifying a message which is addressed to an individual station as a terminal station, and of receiving only that which is necessary for printing. Further, it can insert in the message a control code unit which enables the exchange center to control the terminal station. The function of the second memory selector mechanism is for controlling the principal function of the Kanji teleprinter or the Kanji tape punch typewriter of the invention, that is, to establish the Kanji operational state or the normal operational state, and to dispatch the necessary instructions for printing corresponding characters according to the code units, and to give the necessary instructions for the function and form controls and the like to each appropriate mechanism.

The use of the storage mechanism results in increasing the speed of action of each mechanism of the apparatus of the invention. If the time necessary for the first memory selector mechanism and the second memory selector mechanism to handle the code units is sufficient, and if the time required for identification of the code unit for establishing the operational state and the character code units and the like can be made shorter

than the time for storing the code units, the storage mechanism can be omitted, and the code units can be transmitted directly from the second memory selector mechanism to the type selecting mechanism when the apparatus is in the normal operational state, and when it is in the Kanji operational state the code units can be transmitted from the second memory selector mechanism and the first memory selector mechanism. However, by providing the storage mechanism, the time required for the operating cycle of a single code in the first memory selector mechanism and the time required for identifying the control code in the second memory selector mechanism can be reduced, and thus the operating speed of the entire apparatus can be increased.

A fifth additional feature is that the range of movements of the type-bar case can be reduced when the apparatus is in the normal operational state to one-fourth of the movements when the apparatus is in the Kanji state and the time required to print can be reduced to about one-half of that required when the apparatus is in the Kanji operational state. The time required to perform the printing action of the type-bar is no more than the time required to handle character code units when the apparatus is in the Kanji operational state and the time required to perform the printing action is no more than the time required to handle a single character code unit when the apparatus is in the normal operational state.

BRIEF DESCRIPTION OF DRAWINGS

FIG. 1 is a chart of the ISO code or International Code for Information Exchange showing the correspondence between the characters and symbols and seven element code units;

FIGS. 2A and 2B, which overlap slightly, are parts of a chart showing ISO code units assigned to various characters according to an arrangement of the invention;

FIG. 3 is a chart which is a part of FIGS. 2 and 2B and one arrangement of Kanji characters and code units;

FIG. 4 is a diagram showing the order of arrangement of type-bars in the type-bar case according to the invention and the relationship to the code units;

FIG. 5 is a diagram showing the correspondence between the arrangement of the characters on the type-bar and the code units;

FIGS. 6a-6c are perspective and elevation views of type-bars of the invention;

FIGS. 7, 8 and 9 are isometric projections of the type-bar case encasing the type bars of the invention;

FIG. 10 is a schematic diagram for showing the principle of the mechanism for producing selective leftward and rightward movement and forward and backward movement of the type-bar case;

FIG. 11 is an isometric projection of that part of FIG. 10 showing an arrangement of the additive selector mechanism;

FIG. 12 is an isometric projection of that part of FIG. 10 for operating the clutch mechanism for the operation of the additive selector;

FIG. 13 is a diagram showing the basic principle of the part of the apparatus which effects the raising and the printing of the type-bars;

FIG. 14 is an isometric projection of the mechanism for carrying out the raising action and printing action;

FIG. 15 is an isometric projection of the mechanism for controlling the printing pressure;

FIG. 16 is an isometric projection of the adding mechanism which effects raising selection of the type bars;

FIG. 17 is an isometric projection of the mechanism for spacing during printing and the mechanism which transmits the code units to the mechanisms of FIGS. 15 and 16;

FIG. 18 is an isometric projection of the control mechanism shown in FIGS. 19 and 20, and it shows particularly the common drive mechanism which effects the identification of function code units;

FIGS. 19 and 20, are diagrams of control mechanisms for control of the type selecting printing mechanism, form control mechanism and other control mechanisms of the apparatus by code units;

FIGS. 21 and 22 are isometric projections of the mechanism for transmission of code units to the first memory selector mechanism and the second memory selector mechanism and the storage mechanism;

FIGS. 23 and 24 are an isometric projection and an elevation view of means for identification and selection of functional codes in the first and second memory selector mechanisms; and

FIGS. 25, 26, 27, 28, 29, 30 and 31 are isometric projections of various control mechanisms controlled by function code units.

DETAILED DESCRIPTION OF THE INVENTION

A keyboard used to produce the code units for the Chinese, or Kanji, character teleprinter and the Chinese character tape punch typewriter of the invention is not described herein. The keyboard system of the prior U.S. application Ser. No. 212,330, filed Dec. 27, 1971 entitled "Keyboard System for Chinese Character Teleprinter, Chinese Character Typewriter, Monotype, etc." in the name of Shimeo Ogawa, is one such system which can be used in the present Chinese character teleprinter or Chinese character tape punch typewriter.

In the detailed description of the invention, the ISO Code has been used as an example, and the various terms thereof are used in the drawings and diagrams. However, the scope of the claims of the invention will not be limited thereto and thereby, since it is used only as an example. Also the diagrams and the descriptions of the mechanisms given herein serve only as examples, and the scope of the claims of the invention should not be considered as limited thereto and thereby.

FIG. 1 is a chart of the new international alphabet No. 5 or the aforementioned International Code for Information Exchange which has been studied by ISO and has become the CCITT recommended seven-element code units for transmission of data and messages. FIG. 1 shows the various conditions of the seven-elements, b_1 b_7 , each information unit having two states, the 0 state and the 1 state. By the combination of these states $2^7 = 128$ different code units can be formed. In FIG. 1, the columns at the left show the combination of the states of the four units, b_1 ... b_4 , indicated in the order from 0 to 15, and the rows at the top show the combinations of the states of the three units, b_5 , b_6 , b_7 , in the order from 0 7.

The 32 codes shown in 0 column and 1 column are not for characters but they are control codes, among which are control codes (TC) SOH, STX, ETX, EOT,

ENQ, ACK, DLE, NACK, SYN, ETB, which are control codes for the data transmission system to carry out accumulated switching or circuit switching and for checking communication and to check for hardware errors. The FE code characters are for back spacing (BS), horizontal tab (HT), line forward (LF), vertical tab (VT), form forward (FF), and carriage return (CR), respectively, and control the movement for carrying out the printing. DC₁ - DC₄ are for control of the operations of the terminal equipment, i.e. printing operations, operation or non-operation of a punching machine or starting or stopping of reader operations. IS₁, IS₂, IS₃, and IS₄ are control codes used for sorting of data. CAN is a control code used to cancel specific parts of data. IS₁, IS₂, IS₃, IS₄, CAN, ETB, and EM code characters and the functions carried out thereby have no direct relation with the invention, so their description is omitted herefrom. ESC is a code for establishing a new control code and is used to change the meaning of the code unit produced immediately following production of the code unit for the code ESC. SI and SO have the same meanings as the hithertofore used shift codes, SI designating SHIFT IN, and in the operational state according to this code, each code unit is that of a character indicated in columns 2 - 7 of FIG. 1. Code SO designates SHIFT OUT, and in Japan, in the operational state of the teleprinter apparatus which is established by the SO code unit, Katakana characters are assigned to the individual code units instead of the characters and symbols in columns 2 - 5 of FIG. 1. In the chart of FIGS. 2A and 2B, Katakana characters which correspond to the Roman alphabet characters and symbols are shown in the *x* and *y* row and column beside the respective alphabet characters and symbols. The SP code in column 2 is for a spacing code unit, and the DEL code at the bottom of column 7 is for an erasure code unit. DEL is used to nullify the code units already punched in a perforated tape by changing said punched code units to the code unit for DEL. The NUL code at the top of the 0 column produces a null code unit causing no operation.

In the present invention, the Chinese, or Kanji, characters are handled when the code unit for the code SUB in column 1, row 10 of FIG. 1 is present. In the Chinese, or Kanji, character operational state, two code units in a particular order together represent one Kanji character, and the apparatus carries out a spacing operation associated with the printing of the character and the printing operation. In the Chinese or Kanji character teleprinter or tape punching typewriter of the invention, the SI operational state, the SO operational state, or the SUB operational state are established when the respective control code units are received by the device. In the SI operational state, each code unit causes the device to print an alphabet character, a number or a symbol shown in the columns of FIG. 1 and to carry out the spacing operations associated with printing of such characters. In the SO operational state, each code unit causes the device to print Katakana characters corresponding to the code units and to carry out the spacing operations associated with printing of such characters. In the SUB operational state (the Chinese, or Kanji, character state) the code units are combined into sets of two code units in a particular order, and the code units cause the device to print the Chinese, or Kanji, characters, and to carry out the spacing operations for such characters. The control codes in

the 0 and 1 columns and the characters in columns 2 - 7 of FIG. 1 which the code units designate in the SI operational state are for programs which control electronic computers and the values used for calculations; they have been agreed to internationally as control codes to control message-switching and automatic error correction of data communication systems. The Katakana characters which the code units designate in the SO operational state are used for representing information expressed in the original Japanese. Consequently, Chinese or Kanji, characters which the code units designate in the SUB operational state according to this invention also serve to make the content of information more readily understandable. For processing information which includes such Kanji information by means of an information processing system, the apparatus of this invention is highly effective.

The number of code units which are available for the characters in columns 2 - 7 is 94, excluding codes SP and DEL: therefore, if they are grouped into sets of two there will be $94 \times 94 = 8,836$ sets. Currently available Chinese character teleprinters accommodate 2,300 - 2,800 code units, and it is now desirable to increase the number to 4,000. Therefore, to arrive at a number closest to this number, a combination of code units having 12 elements, or $2^{12} = 4,096$ code units, seems the most practical size for a machine or equipment, and the subsequent description is based on equipment of this size.

If in FIG. 1 the number of code units to be used to designate Kanji characters in the SUB operational state is limited to 64, i.e. to the code units for the spaces in columns 2 - 5 (including SP), then to obtain these 64 code units, only six code elements, $b_1, b_2, b_3, b_4, b_5, b_7$ are sufficient, and code element b_6 need not be used. A combination of two code units can be represented by 12 code elements, and the total number of such twelve-element code units which is available is 4,096. The manner of assigning code units to Kanji characters is shown in FIGS. 2A and 2B. Let the first of the two code units which represent one Kanji character be designated as the X code unit, and in FIGS. 2A and 2B X code units are shown in the horizontal rows. Let the second code unit immediately following the X code unit be designated as Y the code unit and Y code units are shown in the vertical columns. $Xb_1, Xb_2, Xb_3, Xb_4, Xb_5, Xb_7$ and $Yb_1, Yb_2, Yb_3, Yb_4, Yb_5, Yb_7$ are the elements of the X code units and the Y code units corresponding to code elements $b_1, b_2, b_3, b_4, b_5, b_7$, respectively. In both cases the code units for the characters in column 6 and column 7 in FIG. 1 are not used, so code element b_6 is omitted. In the X rows immediately beneath the X code units, the Roman alphabet characters, numbers, and symbols designated by the X code units in the SI operational state are shown in the lower row, and Katakana characters designated by the X code units in the SO operational state are shown in the upper row. Henceforth to indicate code units, the corresponding alphabet character, number or symbol will be used. The same relationship is shown in the Y columns to the right of the Y code units.

In FIGS. 2A and 2B, there is a column of spaces for each 64 X code units and a row of spaces for each 64 Y code units, for a total of 4,064 spaces, and each space contains a Chinese, or Kanji character, Hiragana character, Katakana character, Roman letter, numeral, or symbol, each of which is designated by two code

units in the SUB operational state. When so many characters are used, it is desirable that some consideration be given to the order of the arrangement and the frequency in use. The order of arrangement of characters is important when the keyboard of the apparatus for producing the code units is manipulated by man, and arrangement according to frequency in use will have a direct bearing on the efficiency and life of the printing machine when a Chinese character teleprinter or monotype or type group, or matrix is selected by mechanical movements. The block of spaces indicated by the 48 X and Y code units for 0 1 2 3 4 ... X Y Z [¥] ^ - in FIGS. 2A and 2B is capable of accommodating 48 x 48 = 2,304 characters, and the 2,304 characters which have hitherto been used in newspapers and the like can be accommodated therein. This is because of the construction of a keyboard preferably provided with 48 independent character keys, in the keyboard system described in the specification of said patent application Ser. No. 212,330. The block of spaces indicated by X code units ! " # % ! () * + , - . / and Y code units 0 1 2 3 4 ... X Y Z [¥] ^ - and the block of spaces indicated by Y code units S P " # % & ' () * + , - . / and X code units 0 1 2 3 4 ... X Y Z [¥] ^ - are for accommodating characters other than the 2,304 frequently used characters, i.e. characters having a low frequency of use. The block of spaces indicated by the X and Y code units S P ! " # % & ' () * + , - . / accommodates, as shown by FIGS. 2A and 2B, the characters designated by a single code units in the SI and SO operational states and characters having the lowest frequency of use. By bringing together and arranging the characters designated in the SI state and the SO state as in FIGS. 2A and 2B, these characters can be printed when the apparatus is in the SUB state by combining X code units and Y code units, as well as printing these characters by using one code unit when the apparatus is in the SI and SO operational states. This is a significant feature of the invention about which will more be described hereinafter. No characters are placed in the SP column of X code units. This is because the SP code unit is used as a spacing code when the apparatus is in the SUB operational state, SI operational state, and the SO operational state. In the SUB operational state when the Y code unit designated the SP code, Chinese characters can be designated by making the X code unit a unit other than that for the SP code, the therefore characters can be arranged in the Y code unit row for the SP code. Therefore it is possible to accommodate in the chart of FIGS. 2A and 2B 63 x 64 = 4,032 characters.

FIG. 3 shows part of one example of an arrangement of characters in the block of spaces designated by X and Y code units 0 1 2 3 4 ... X Y Z [¥] ^ -. FIG. 3 shows part of the characters arrangement for the character board and the keyboard system of said patent application Ser. No. 212,330. In FIG. 3 the 48 x 48 = 2,304 characters accommodated are sub-divided into four groups based on frequency of use, and those having the greatest frequency of use are in the central square block of spaces designated by the 24 code units <=>?@ABC.....PQRS. Those with the second greatest frequency of use are in the upper and the lower blocks of spaces designated by X code units <=>?@A B C P Q R S and Y code units T U V W X Y Z [Y] ^ - and 0 1 2 3 4 5 6 7 8 9 ; ; . Those with the third greatest frequency of use are in the left and the right

blocks of squares designated by Y code units, <=>?A B C - P Q R S and X code units, T U V W X Y Z [¥] ^ - and 0 1 2 8 9 ; ; . Those with the lowest frequency of use are in the blocks of spaces designated by the X and Y code units T U V W X Y Z [¥] ^ - and 0 1 2 3 4 5 6 7 8 9 ; ; respectively. Such groupings by frequency in use are used in the currently available Chinese character (Kanji) teletypes and in all automatic monotypes, and this system of grouping has been adopted in the present invention, so that when the apparatus of the invention is linked to and operated with the currently available machines the efficiency of said machines will not be affected. In FIG. 3 the characters accommodated in the block of spaces where Hiragana characters designated by X code units H I J K L M and Y code units <=>?@ABC.....PQRS are so-called "First class characters" (highest frequency in use) in Japanese typewriters, and as shown in FIG. 3 they should be arranged as close together as possible. Since Katakana characters and Roman letters A B C D X Y Z are, as shown in FIG. 3 used in conjunction with names of places, articles and the like they should be arranged close together. Characters with small surface areas requiring adjustment of printing pressure are contained in the 32 sections defined by the Y code units T U V W, and by the eight X code units D E F G and T U V W, and their positions have been arranged so as to make it possible to designate them by the same X and Y code units. For other characters, location according to frequency of use are selected first, and in each block of spaces for a given frequency of use, characters are arranged by the manner of reading the characters or by the form of the characters, and the characters are arranged for ready indexing by means of a key board system. Also in FIG. 3 are shown characters classified in the order of "A I U E O" (Japanese alphabet) and brought together in the same location for ready and easy indexing on the keyboard, without any relation to the frequency in use, but according to the keyboard system and the special features of the character-board described in patent application Ser. No. 212,330, and part of the example in which the characters are arranged in blocks according to the frequencies in use. An arrangement of characters in the "A" category and in the "1" category are shown in FIG. 3.

In the diagram of the type case shown in FIG. 4, each character arranged in each section of FIGS. 2A and 2B is included in a group of eight characters on one type-bar, and the arrangement of type-bars, each with a group of eight characters thereon, in the type-bar case, and the relationship of the characters with code elements for X code units and Y code units are shown. FIG. 5 shows a concrete example of a type-bar with an arrangement of eight characters and their relationships with the code elements. Accordingly, in FIG. 4 in the direction of X axis there are 15 type-bar sections, and in the Y-direction are 32 type-bar sections in the type-bar case. The X axis direction is the width and the Y axis direction is the length. Each of the sections contains a type-bar with eight raised characters as shown in FIGS. 5 and 6. In FIG. 4 for each column in the X axis direction there is shown a combination of code elements Xb₇, Xb₅, Xb₄ and Xb₃, and for each of the rows 0 - 31 in the Y axis direction there is shown a combination of code elements Yb₇, Yb₅, Yb₄, Yb₃ and Yb₂. Moreover, combinations of code elements Xb₁, Xb₂ and Yb₁ as shown in FIG. 5 designate the positions of

the eight characters on a single type-bar. Consequently, for each combination of an X and a Y code unit as described above in connection with FIGS. 2A and 2B, there will be a corresponding column and row of the type-case and a position on the type-bar, so that the position of the designated Kanji character on the type-bar and the particular type-bar will be determined, and the character corresponding to the X code unit and the Y code unit can be selected. The left hand type-bar of FIG. 5 is as indicated by comparing the code units for the numbers thereon according to the chart of FIGS. 2A and 2B and FIG. 3 with the code elements of FIG. 4 and FIG. 5, which is in the section designated by column 1 and row 2 of FIG. 4, and the middle type-bar of FIG. 5 is the type-bar which is contained in the section in column 9 and row 20 of FIG. 4. The right hand type-bar is the type-bar contained in the section in column 10 and row 14 of FIG. 4.

FIG. 6 shows the structure of the type-bar. On the front surface of type-bar 1 are located eight raised type members arranged according to the code units designating them, as explained above with reference to FIGS. 2A, 2B, 3, 4 and 5, and on the back thereof is rack 19. Rack 19 is plastic molded simultaneously with the type on the front surface, and this makes it easier to raise the type. The type and the teeth of the rack are placed opposite to each other and by means of the teeth the type members can be placed in a position opposite to the platen. Edges 20 and 21 of type-bar 1 serve as guides when the type-hammer, which will be described later, is actuated. Projection 22 at the bottom of the type-bar serves to protect the type surface when type-bar 1 is returned to the type-bar case after completion of a printing operation.

FIGS. 7, 8 and 9 show the construction of the type-bar case which accommodates the type-bars in the arrangement of FIG. 4. The type-bar case is a cast frame 30, the inside of which is partitioned into sections by thin panels 31 and 32 extending in the leftward and rightward direction and in the forward and backward direction.

Partition panels 31 extending in the leftward and the rightward direction and partition panels 32 extending in the forward the backward direction are, as shown by the construction of FIG. 9, alternately placed. Shoulders 33 and 34 are provided on the partition panels 31 and 32 and are supported by the upper edges of frame 30 and fixed to frame 30 by brackets 35 and 36 positioned thereover. At the lower part of the front and backs of each partition panel 31 is a hole 37 through which piano wires 38 are inserted to support support plates 40 for supporting the type-bars. A support plate 40 is provided for every row of FIG. 4, and each support plate is provided with a plurality of bell-shaped guide holes, one for each push-up pole (which will be described later) to push up a type-bar 1. The shoulders 42 and 43 at the opposite ends of support plate 40 are engaged, respectively, in guide grooves 44 in the lower edge of frame 30 and in guide grooves 46 in supporting frame 45 attached to frame 30 to maintain the relative position of the frames 45 accurately with respect to frame 30.

Projecting parts 48 and 49 projecting downwardly from the sides of frame 30 are connected to shaft 50 which drives the type-bar case in the forward and the backward direction and is capable of sliding freely in the direction of its own axis. Edge 51 of supporting

frame 45 attached to frame 30 is supported by roller 52, and guide plate 53 prevents the turning of frame 30 about shaft 50 so as to maintain the horizontal position of frame 30. Roller 52 is attached to guide plate 53 which in turn is fixed to bar 54, and the other end 55 of bar 54 has a ring shaped support bracket 56 thereon around shaft 50. Shaft 50 and bar 54 are moved by an additive selector mechanism in the forward and backward direction, as will be described later, to carry out the selective movements of the type-bar case in the forward and backward direction. The type-bar case can move freely from left to right on shaft 50 and bar 54. Rollers 577 and 578 attached to one end of frame 30 engage on opposite sides of a straight base 573 of a hollow triangular bar 57 through which the type case is moved by the additive selector mechanism in the leftward and rightward direction.

FIG. 10 is a diagram of the mechanism which causes the selective movements of the type bar case in the leftward and rightward direction and in the forward and backward direction according to the code elements of a set of code units to position the type-bar case with a section designated by code elements of FIG. 4 in a printing position. The code elements of the X code unit and Y code unit indicate directly the amounts of movement. Accordingly, when only element Yb_2 changes from 0 to 1 or from 1 to 0, and Yb_3, Yb_4, Yb_5 and Yb_7 do not change, the type bar case is made to move to the selected position corresponding to the code units by moving the type bar case in the forward and backward direction by the amount equivalent to only one section. Similarly, when only element Yb_3 changes from 0 to 1 or from 1 to 0, the type case must be moved an amount equivalent to two sections. When Yb_5 changes, the case must be moved an amount corresponding to eight sections, and when Yb_7 changes, the movement will correspond to 16 sections. When more than two code elements change, the amount moved for each changed code element will be added algebraically, and thus the selective movement of the type bar case corresponding to a code element change is performed. The aforementioned is also applicable for the selective movement in the leftward and rightward direction in accordance with changes in the code elements Xb_3, Xb_4, Xb_5 and Xbb_7 .

In FIG. 10, the same numbers are used for the shaft 50 and bar 54 which support the type bar case, and for the hollow triangular bar 57 which drives the type bar case in the leftward and rightward direction as are used in FIGS. 7-9. In FIG. 10 shaft 50 has the ends 501 and 502 thereof pivotally connected to end 581 of lever 58 and to end 591 of lever 59, respectively. Lever 58 rotates around fixed support 583, and lever 59 rotates around fixed support 593, and the other end 582 of lever 58 and the other end 592 of lever 59 are pivoted to ends 601 and 602 of link 60, respectively. Bar 54 has its one end 541 pivoted to shaft 50 at the central point 503 of shaft 50, and the other end 542 of bar 54 is pivoted on the end 611 of bar 61. Lever 61 rotates about fixed axis 612. By the actions of levers 58, 59 and 61 and link 60, shaft 50 and bar 54 can effect, without changing the direction of either, the same horizontal motion as the motion of the end 611 of lever 61. Therefore, only the motion in the forward and backward direction which is a component of the angular motion of end 611 of lever 61 is transmitted to the type bar case supported by shaft 50 and bar 54. Hollow triangular

bar 57 is connected at points 571 and 572 thereon to end 621 of lever 62 and to end 631 of lever 63, respectively. Lever 62 rotates about fixed point 622, and lever 63 rotates about fixed point 632, and hollow triangular bar 57 performs, without changing its direction, the same horizontal motion as does the end 631 of lever 63. Base 573 of triangular bar 57 which drives the type bar case performs straight movements in the leftward and rightward direction and only the leftward and rightward motion of the angular motion of end of 631 of lever 63 is transmitted to the type bar case. The additive selector mechanism which moves the type bar case in the forward and backward direction comprises levers 64, 65, 66 and 67, links 68, 69, 70, 71 and 72 and is driven by a selection means comprising clutch cam mechanisms 80, 81, 82, 83 and 84. Also the additive selector mechanism which moves the type bar case in the leftward and rightward direction comprises levers 73, 74 and 75 and links 76, 77, 78 and 79 and is driven by clutch cam mechanisms 85, 86, 87 and 88 also forming part of the selection means. Support 641 for lever 64 is connected to axis 613 located on lever 61, support 651 for lever 65 is located on the end 643 of lever 64, support 661 for lever 66 is connected to end 652 of lever 65, and support point 671 for lever 67 is connected to point 642 of other end of lever 64. Both ends 663 and 662 of lever 66 are pivotally connected, respectively, to ends 691 and 701 of links 69 and 70. Links 69 and 70 are moved by clutch cam mechanisms 81 and 82. The other end 653 of lever 65 is pivotally connected to end 681 of link 68, and link 68 is moved by cam mechanism 80. Also both ends 673 and 672 of lever 67 are pivotally connected, respectively, to ends 711 and 721 of links 71 and 72, and links 71 and 72 are moved by cam mechanisms 83 and 84, respectively. Support 731 for lever 73 is joined to the end 633 of the short arm of bell crank lever 63 and support 741 for lever 74 is joined to end 733 at one end of lever 73. Support 751 for lever 75 is joined to end 732 at the other end of lever 73. Both ends 742 and 743 of lever 74 and both ends 752 and 753 of lever 75 are pivotally connected to ends 761, 771, 781 and 791 of links 76, 77, 78 and 79, respectively. Links 76, 77, 78 and 79 are moved by cam mechanisms 85, 86, 87 and 88, respectively.

Cam mechanisms 80-88 correspond, respectively, to the code elements in FIG. 4 that define the position of the type bar case in the forward and backward direction and in the leftward and rightward directions as follows.

Cam mechanism	80—Y code element	Yb ₄
Do.	81— do.	Yb ₂
Do.	82— do.	Yb ₃
Do.	83— do.	Yb ₃
Do.	84— do.	Yb ₅
Do.	85— do.	Xb ₄
Do.	86— do.	Xb ₃
Do.	87— do.	Xb ₇
Do.	88— do.	Xb ₅

Each clutch mechanism has two stop positions one-half a rotation, i.e. 180°, apart, one for the 0 state and the other for the 1 state of each code element. When the incoming code element corresponds to the stop position of the clutch the state of rotation remains unchanged but when the state of the incoming code element is opposite to that which the stop position represents, the incoming code element will rotate the clutch mechanism 180° to the stop position corresponding to

the opposite state, i.e. from the 0 to the 1 state or vice versa. By the actions of cam mechanisms 126, 127, 128, 129, and 130 of clutch cam mechanisms 80 - 84, links 68 - 72 will be positioned such that they tend to move the type case to the front when the corresponding code element is 0 and when it is 1 they will be positioned in the opposite position tending to move the case to the back. If the stop position of the clutch cam mechanism corresponds to the 0 state and the code element which arrives is 1, the links will move from the front position to the rear. If the stop corresponds to the 0 state and the code element which arrives if 0, the opposite action will take place. When the state of the code element corresponds to the state represented by the stop position of the cam mechanism, there will be no change in the stop position. The amount of positional change of links 68 - 72 need not be the same, and a different value can be given to each code element. However the present designation, taking into account that the apparatus will be mass produced, will assume that each clutch cam mechanism produces the same amount of positional change of the corresponding link.

The positional changes of links 68 - 72 produced by changes in the states of the code elements are transferred as such to positional changes of levers 65, 66 and 67 which are link-connected thereto at points 653, 663, 662, 673 and 672. On lever 66 the position of support 661 must be so chosen that the ratio of the amount of positional change of support 661 when 663 experiences a positional change but 662 does not, to the amount of positional change of support 661 when 663 does not experience a change in position but 662 does, is 1:2. Similarly with lever 65, the position of support 651 must be so chosen that the ratio of the amount of positional change when one end 652 alone undergoes a positional change to the amount of the positional change of support 651 when the other end 653 alone changes is $3/4 = (1 + 2) : 4$. Similarly, the position of support 671 must be so chosen that the ratio of the amount of positional change when one end 672 alone undergoes a positional change and when the other end 673 alone undergoes a positional change is 1:2=8:16.

Furthermore, for lever 64 the position of support 641 must be chosen so that the ratio of the amount of positional change when one end 643 alone changes position to the amount of positional change when the other end 642 alone changes position must be $7:24 = (1 + 2 + 4) : (8 + 16)$. When links 69, 70, 68, 72, 71 perform, respectively, the same amount of positional change in accordance with the change in the code elements by means of the additive selector mechanism comprising levers 64, 65, 66, 67, the respective positional changes will affect connection 613 between lever 61 and lever 64 in the respective ratio 1:2:4:8:16 and lever 61 will perform the positional change of each of links 69, 70, 68, 72, 71 increased algebraically by the ratio 1:2:4:8:16. The positions of 613 and 611 are so selected when lever 61 moves the range of motion of support 613 relative to fixed support 612 is such as to cause 611 to move the type bar case a distance equal to an appropriate number of sections. Thus the selective motion in the forward and backward direction of the type bar case is carried out according to the changes in the states of the respective code elements which cause changes in the positions of the clutch cam mechanisms 80, 81, 82, 83, and 84.

The leftward and the rightward directional selective motion of the type bar case is achieved in a similar manner. The positional changes in clutch cam mechanisms 86, 85, 88 and 87 corresponding to the changes in the state of the X-code are transmitted in the respective ratio 1:2:4:8 to end 633 of bell crank lever 63 through levers 74, 75, and 73 from links 77, 76, 79, and 78, and the positional change is magnified the necessary selective motion of the type bar case in the leftward and rightward direction.

FIG. 11 illustrates the actual structure of the shaft 50, bar 54, link 60, levers 58 and 59, hollow triangular bar 57, levers 61, 62, 63, 64, 65, 66, 67, 73, 74 and 75, and links 68, 69, 70, 71, 72, 76, 77, 78 and 79 in isometric projection.

In such an additive selector mechanism it is important that the links 68, 69, 70, 71, 72, 76, 77, 78 and 79 be sufficiently long. That is the links must be sufficiently long so that errors in the positions of the type bar case caused by any slight difference in the forward and backward motion produced, for example, by clutch cam mechanism 80, or a slight displacement of ends 681 and 691 and of links 68 and 69, and the others, in the leftward and rightward directions, which is caused when levers 65, 66, 67, 64 and 61 comprising the additive selector mechanism start their individual rotational motions, can be neglected.

If the links are sufficiently long and adjustable connections are provided at certain points, and amount of displacement produced by the clutch cam mechanisms can be transmitted accurately as an amount of displacement in the forward and backward direction to the ends of the levers to which the links are connected, and even though the motion of the additive mechanism is composed of the rotational movements of the levers which are parts of the mechanism, the amount of displacement of each link which is transmitted will appear as part of the amount of displacement of end 611 of lever 61 end 631 of lever 63 in the forward and backward direction or leftward and rightward direction and will maintain the aforementioned ratio.

For example, with lever 66 if connection 662 is adjustable then any manufacturing error in the amount of displacement transmitted by clutch cam mechanisms 81 and 82 can be corrected and the ratio of the amounts of displacement of the ends of lever 66 produced by these mechanisms can be adjusted to 1:2. Similarly, by making connections 653, 643 and 611 and 742, 753, 733, 631 and 621 adjustable, manufacturing errors causing errors in the displacements produced by clutch cam mechanisms 80 - 88 and the manufacturing errors in levers 61, 62, 63, 64, 65, 66, 67, 73, 74 and 75 can also be corrected, thus making it possible to carry out the positioning operations of the type bar case more accurately. Also by making the length of some of the links very slightly adjustable, like links 69 and 77, in each additive mechanism, it is possible to adjust accurately the basic position of the type bar case in the forward and backward direction and in the leftward and rightward direction.

The structure of clutch cam mechanisms 80, 81, 82, 85 and 86 is different from that of clutch cam mechanisms 83, 84, 87 and 88. Clutch cam mechanisms 83, 84, 87 and 88 operate only when the apparatus is in the Chinese character operational state, and when extensive movements of the type bar case are to be made. In this type of clutch an eccentric cam as shown in FIG.

12 can be used. Clutch cam mechanisms 80, 81, 82, 85, 86 operate when the apparatus is in the normal or in the Kanji operational state, but in the normal operational state, the time required for such operation that is, the time required for shaft 153 shown in FIG. 12 to make one-half a revolution, must be one-third the time for the operation of the eccentric cam.

FIG. 12 shows the mechanisms for the two types of clutch cams and the driving mechanism therefor. Shaft 153 indicated in FIG. 10 is shown in broken form in FIG. 12. Clutch case 154 fixed on shaft 153 corresponds to cases 144, 145, 146, 149 and 150 of the clutches of FIG. 10, and clutch case 155 corresponds to cases 147, 148, 151 and 152 of the clutches of FIG. 10. A clutch disc corresponding to clutch discs 135, 136, 137, 140 and 141 are shown at 156 in FIG. 12, and mechanisms corresponding to the mechanisms 138, 139, 142 and 143 are shown at 157 of FIG. 12.

A cam corresponding to eccentric cams 129, 130, 133 and 134 in FIG. 10 are shown at 158 in FIG. 12 and it is fixed on clutch disc 157. A part corresponding to parts 120, 121, 124 and 125 engaged with the eccentric cams 129, 130, 133 and 134 are shown at 159 of FIG. 12. A cam corresponding to cams 126, 127, 128, 131 and 132 of FIG. 10 is shown at 160 in FIG. 12 and a part corresponding to parts 117, 118, 119, 122 and 128 connected with the cams 126, 127, 128, 131 and 132 are shown at 161 in FIG. 12. On part 161 are mounted two rollers 162 and 163 as shown in FIG. 12 which follow the profile cam 160 to move part 161 in the forward and backward direction. In order to maintain part 161 at the same level relative to shaft 153, part 161 has a groove 164 therein in which is fitted an extended part 165 of a sleeve on the shaft. A clutch lever 166, shown in FIG. 12 is provided on each clutch disc, and it disengages the clutch when one end 167 of the clutch disc is engaged by a corresponding stop lever 168 or stop lever 169 to stop the rotation of cam 160 and cam 158 which are connected to clutch discs 156 and 157, respectively. A rapid engaging type friction clutch formed by connecting a clutch disc and a clutch case often used in a teleprinter can be replaced by a gear clutch or any other suitable type clutch, and no description will be given therein of the internal clutch mechanism. Stop levers 168 and 169 are arranged to stop the clutch disc at positions 180° apart. Each clutch is provided with a set of stop levers.

Stop levers 168 and 169 stop the clutch mechanism in positions corresponding to the 0 state and the 1 state of the code elements, respectively. Two sets of stop lever actuators 89 - 97 and 98 - 106 are shown in FIG. 10, one pair for each pair of stop levers. Corresponding fingers 170 and 171 are shown in FIG. 12. Fingers 170 and 171 have depending projections 172 and 173 which engage the bent ends of stop levers 168 and 169 to move the stop levers. By this movement the state of the code elements is transmitted to the clutch cams.

As was described in connection with FIGS. 2A and 2B, code units made up of different code elements represent different characters in the Chinese character operational state, the SI operational state, and the SO operational state. The state of the code elements for the code units in the various states must be supplied to the same set of clutches. When FIG. 10 and FIGS. 1, 2A and 2B, and 4 are compared, the relationship between the elements of the code units and the states of the se-

lection means as controlled by the code unit elements becomes as shown in Table 1.

Table 1

Element of the Section Means	Controlling Code Elements for Chinese Character operational state	Code Elements for SI and SO Operational States
Clutch Cam Mechanism		
80	Yb_4	$SI=0, SO=1$
81	Yb_2	b_4
82	Yb_3	b_5
83	Yb_7	Fixed to 0 State
84	Yb_5	Fixed to 0 State
85	Xb_4	b_7
86	Xb_3	b_6
87	Xb_7	Fixed to 0 State
88	Xb_5	Fixed to 0 State
Selective Raising Mechanism		
1P	Xb_1	b_1
2P	Xb_2	b_2
4b	Yb_1	b_3

The selective raising mechanism will be described later. The code elements for setting the clutch cam mechanism for the SI and SO operational states are the code elements which will set clutch cam mechanism to the 0 state for the SI operational state and to the 1 state for the SO operational state. This will be described more fully later.

In FIG. 12 finger 170 operates the stop levers according to the state of the code elements in the Chinese character operational state, and finger 171 operates the stop levers according to the state of the code elements in the SI and SO operational states. Finger 170 is coupled with a bell crank 175 and held in engagement therewith by spring 177, and upon the rotation of bell crank 175, projections 172 on finger 170 are moved into position opposite to stop lever 168 or stop lever 169. When the code element is in the 0 state, projection 172 is moved opposite stop lever 168 and when it is in the 1 state the projection is moved into position opposite stop lever 169. The other end of bell crank 175 is coupled to a bar 179 and the state of the code elements is indicated by the displacements of bar 179. Thus, to change a clutch cam mechanism, the bell crank 175 is moved by movement of bar 179 to bring projection 172 of finger 170 into position opposite stop lever 169 or stop lever 168, depending on the state of the clutch mechanism and the incoming element to release end 167 of a clutch. Similarly, projection 173 on finger 171 is moved into position opposite stop lever 168 or 169 by means of bell crank 176 and spring 178 actuated by bar 180. The number of bars 179 and 180 is equal to the number of code elements, as shown in Table 1, necessary or designating a character. The bars will be connected to bell cranks corresponding to bell cranks 175 and 176 at the different clutch cam mechanisms according to Table 1 above. E.g., clutch cam mechanism 82 will have the bar for code elements Yb_3 and b_5 coupled thereto. Projections 172 and 173 on fingers 170 and 171 are different in shape to indicate that the direction of motion of the fingers corresponding to

the state of the code elements will be opposite depending on the shape of bell cranks 175 and 176. Springs 177 and 178 keep fingers 170 and 171 in constant contact with stop bar 181 and keep projections 172 and 173 separated from stop levers 168 and 169, respectively.

Operating arms 174 for each clutch cam mechanism are attached to shift bail shaft 107 and they correspond to arms 108 - 116 in FIG. 10. Shift bail shaft 107 forms the switch-over from the Chinese character operational state to the SO and the SI operational states and also initiates the movement of the type bar case. Sleeves 182 and 183 and arm 185 are fixed to shift bail shaft 107. Levers 188 and 189 are engaged in grooves in sleeves 182 and 183, and push pole 383 (described in connection with FIG. 19) acts on the levers to move the shift bail shaft 107 in the axial direction thereof. When the shift bail shaft 107 is positioned so that operating arms 174 are placed in position to engage fingers 171, the apparatus will operate in the SI and SO operational states. Link 394 (to be described in connection with FIG. 20) is engaged with stud 186 on the end of arm 185, and in order to initiate the selective movement of the type bar case, shift bail shaft 107 is turned by movement of link 394, and either finger 170 or finger 171 is pushed down by means of operating arm 174 to cause either stop lever 168 or stop lever 169 to operate. When stop lever 168 turns, as a result of being engaged by finger 170 or finger 171, stop lever 168 will be moved out of the way of end 167, so that clutch disc 156 or 157, when clutch lever 166 engages with stop lever 168 and is stopped, starts turning and immediately moves to the position with stop lever 169 and stops at the position to maintain the state. When clutch disc 156 or 157 reaches the position of stop lever 169 and stops, even if stop lever 168 is acted on by finger 170 or 171 and turns, the state of the clutch disc will be maintained. When stop lever 169 is acted on by finger 170 or 171, by the same operation, clutch disc 156 or 157 will move to the position of stop lever 168 and that state will be maintained. Cam 160 or cam 158 turns with clutch disc 156 or 157, and the action is transmitted to the aforementioned additive selector mechanism by means of links 161 and 159, and action of type bar case will be carried out. Shift bail shaft 107 in FIG. 10 and sections of clutch cam mechanisms 80 - 88 are shown as such in FIGS. 19 and 20, and the relation between FIG. 19 and FIG. 20 will be described later.

FIG. 13 is a diagram illustrating the means for selective raising of the type bars and printing. FIG. 14 is a drawing showing in detail the structure of selective raising and printing mechanisms. FIG. 15 shows the means for controlling the printing pressure and FIG. 16 shows the means for selective raising of types under control of the code elements. FIG. 17 shows a control mechanism which will be further described in connection with FIG. 20, which mechanism transmits to the system of FIG. 13 the action for selective raising of the type-bars, and a mechanism for supplying code elements for selection.

Referring to FIGS. 13 and 14, type-bar 1 is placed on top of support plate 40 in the aforementioned type bar case, and when positioning of the type bar case is complete, the selected type-bar 1 is raised by type pushing pole 190 to a position corresponding to the position of a type hammer located above the pushing pole. Type

pushing pole 190 is supported by upper guide 193 mounted in holder 192 and lower guide hole 194 in holder 192, and is moved in the vertical direction by lever 195. Under normal conditions lever 195 is held in the lower position against the action of spring 196, but when the printing action starts it rises and pushes up type pushing pole 190, which is guided in guide hole 40 in support plate 40 and pushes up type-bar 1. Type hammer 191 is a mechanism which is supported on shaft 199, and on the front surface of the type hammer are mounted two guide plates 200 and 201 and together with a groove 202 provided on the front surface of type hammer 191 they form a guide groove for type bar 1. Inside the type hammer 191 are type hammer gears 204 and 205, and a further gear 203 is mounted in type hammer 191 fixed on shaft 199, and there is also provided a mechanism that transmits the movement of the rising type-bar from shaft 199 to gear 203 and to gears 204 and 205. Gears 204 and 205 rotate about axles 206 and 207 in the type hammer 191. Special spring 208 and gear 209 are fixed on shaft 199, and gear 209 is engaged with a rack 210. Connection 211 on rack 210 is pivotally connected with a driving arm 212 extending from the selective raising mechanism. Normally, rack 210 is located in the rightward position in FIG. 14, being urged there by the action of driving arm 212. However it is acted on by spiral spring 208 while being controlled by the selective raising action of driving arm 212 so as to be moved to the left and moves to the position selected by the code elements Yb_1 , Xb_1 and Xb_2 . Movement of rack 210 releases the transmission mechanism comprising lever 213, link 214, arm 216 and shaft 215, and lever 195, under the action of spring 196, pushes up type pushing pole 190 and to insert the selected type-bar 1 into the guide groove formed in the type hammer 191. The rack 19 (FIG. 6) provided on the back surface of type-bar engages with gear 203. The speed of the rise of the type pushing pole 190 and the peripheral speed of gear 203 will be the same, since both are governed by movement of the same rack 210, so that smooth mutual engagement of the rack 19 and gear 203 is maintained.

After the type-bar 1 engages gear 203, the bar rises further and arrives at a position where the rack 19 on the bar can engage gear 205. Gear 205 rotates in the same direction as gear 203, with gear 204 as an intermediate gear, and type-bar 1 is further raised by means of the two gears 203 and 205. In the extreme case the lowest type (type in FIG. 6) on type-bar 1 can be raised to the position at gear 205.

Between the guide plates 200 and 201 attached to type hammer 191 opposite to gear 205 is, as shown in FIG. 14, an open space and the type on the type-bar 1 is, when the type-bar 1 is in the groove, opposite to platen 207 so that printing can be carried out. Parts 218 on guide plates 200 and 201, each act as a plate spring and press the edges 20 and 21 of type-bar 1 lightly against the type hammer to stabilize the position of the type. Type hammer 191 is pulled to the right in FIG. 14 by the action of typing spring 219, and is pushed to the left by link 220 for printing. Arm 221, sleeve 222 and arm 223 are fixed to each other, and rotate on shaft 225, and the extreme end of arm 221 is pivotally connected to link 220. The extreme end of arm 223 is engaged by cam lever 224, against which it is urged by the action of spring 227 connected to arm 223, and cam lever 224 is moved by type hammer posi-

tioning cam 226 mounted on shaft 856. Under normal conditions cam lever 224 is at the recessed part of cam 226, and the type hammer 191 is inclined toward the right in FIG. 14 and is sufficiently spaced from platen 217 so that the operator of the apparatus can easily see the last character printed on the paper on the platen. During the course of movement of the type bar case, cam 226 turns and rotates cam lever 224 in the clockwise direction, and through the actions of arm 223, sleeve 222, arm 221 and link 220, moves the type hammer 191 to a vertical position near platen 217. After the raising, printing and lowering of the type-bar 1, type hammer 191 returns to the normal position.

The printing action is performed by type striker 230. Type striker 230 is supported on arm 231 fixed on shaft 225 and arm 232 on shaft 199 and it moves horizontally. Spring 219 is connected between the end of arm 231 and type hammer 191. A stud 235 fixed to arm 231 is held in groove 234 on the end of striker 230 by spring 233.

At the other end of shaft 225 are mounted cams 236, 237 and 238 for adjusting printing pressure. Although arm 231 is urged to turn in the counterclockwise direction by the action of spring 219, type hammer 191 is spaced from platen 217 under normal conditions and is in contact with the left end of type striker 230, so spring 219 exerts no direct action thereon. Striker 230 and type hammer 191 are thus pulled back in the clockwise direction by spring 227 acting on arm 221 which in turn has a detent thereon engaging a detent on arm 231. At this time latch levers 239, 240 and 241 are already in the paths of the projections on cams 236, 237 and 238. When arm 221 turns in the counterclockwise direction and places type hammer 191 in the vertical position, one or the other of cams 236, 237 and 238 will engage the corresponding latch lever 239, 240 or 241 and block rotation of arm 231. Thus type hammer 191 will move away from the left end of type striker 230 and spring 219 will be extended so as to exert a strong force on arm 231.

When type-bar 1 is raised to the selected position, latch levers 239, 240 and 241 are disengaged from cams 236, 237 and 238 in order to perform the printing action. Accordingly, arm 231 will be released and will push type striker 230 due to the force of spring 219, and the left end of type striker 230 strikes the upper part of the type hammer 191 for pressing the type on the type bar against the platen to perform the printing action. The detent on arm 231 strikes the detent on arm 221 to stop the motion of arm 231, but type striker 230 moves to the left against the tension of spring 233 while stud 235 slides in groove 234. By this means, the type hammer is caused to carry out printing action satisfactorily on the surface of the platen. When the printing action is complete, type hammer 191 returns to the position in which it is supported by link 220 by means of the action of spring 219. When type-bar 1 is returned to the type bar case, cam 226 causes type hammer 191 and arm 231 to return to their normal states and latch levers 239, 240 and 241 are again engaged with cams 236, 237 and 238.

FIG. 15 illustrates the mechanism for actuating the latch levers for printing pressure adjustments by means of cams 236, 237 and 238. The mechanism is also shown diagrammatically in FIG. 13. The force exerted by spring 219 on type striker 230 will be greatest when latch lever 239 engages cam 236, since rotation of shaft

225 and arm 231 is blocked early in the movement of arm 221; thus the printing pressure will be a maximum. The printing pressure is about average when latch lever 240 engages cam 237, and the printing pressure is a minimum when the latch lever 241 engages cam 238. When printing in the Chinese, or Kanji character operational state, latch lever 239 is engaged with cam 236. When printing in the normal operational state, on the other hand, latch lever 239 is moved out of the path of cam 236 by pushing the lever end of latch lever 239 up by push pole 244 pivotally connected to the lower end of lever 243, and maintaining it in the raised position by latch 245 engageable with latch lever 239. Therefore, the printing pressure is controlled by the engagement of latch lever 240 with cam 237.

When punctuation marks and other symbols which require a small printing pressure are printed when the device is in the Chinese character operational state, the necessity for such a pressure requirement is indicated by a control mechanism (to be described in connection with FIGS. 19 and 20) through element 246, which acts on lever 247 to the lower end of which push pole 248 is pivotally connected. Push pole 248 acts on the lower end of latch lever 240, and latch lever 240 will be moved out of the path of cam 237 and held by latch 249. Post 801 is mounted on latch lever 240 and engages latch lever 239 to move it out of the path of cam 236 at the same time latch lever 240 is moved. Therefore, the pressure of the printing is under the control of latch lever 241 engaged with cam 238.

Latch lever 241 has a cam follower thereon which runs on the profile of cam 802 on shaft 856. A post 803 is mounted on latch lever 241, so that when cam 802 moves latch lever 241 to free it from cam 238, the action of cam 802 is transmitted to latch lever 239 and to latch lever 240 simultaneously to free them from cams 236 and 237. Therefore, regardless of which of the cams 236 or 238 is engaged with a latch lever, the arm 231 will be released and the printing action will be performed when cam 802 moves latch lever 241. Reset lever 804 has a follower therein which runs on the profile of cam 805 and disengages latches 245 and 246 from engagement with latch levers 239 and 240 under control of cam 805 to return the catch levers to the original positions.

FIG. 16 shows the mechanism for selective raising of the type-bars. The mechanism is also shown diagrammatically in FIG. 13. The selective raising mechanism is a mechanism which controls, by means of code elements the action of drive arm 212 which drives rack 210 shown in FIG. 14, and the basic arrangement is shown in FIG. 13.

Drive arm 212 in FIG. 13 is a floating arm with respect to its movement in its own plane, and it is connected to levers 810 and 811 which similarly can float. Lever 810 has an end 812 connected to one end 813 of drive arm 212, and one end 814 of lever 811 is connected to point 815 of the drive arm 212, both levers are able to turn freely in their own planes. On the other hand, cam lever 817 is pivotally connected to fixed support 816, and normally, it is pushed by a cam 818 on the shaft 856 only in the clockwise direction. Four selector levers, 819, 820, 821 and 822 are mounted on the same axis as cam lever 817, and the end 823 of selector lever 819 is connected to point 824 on lever 811 by link 825. End 826 of selector lever 820 is connected to point 827 on lever 810 by link 828. End 829 of selec-

tor lever 821 is connected to point 830 on lever 811 by link 831. End 832 of selector 822 is connected to point 833 on lever 810 by link 834. Each of the selector levers 819, 820 and 822 is acted on by cam lever 817 in the direction of the arrows and generally they are kept at positions in which they are fully turned in the clockwise direction. By the action of spring 208, each will be turned in the counterclockwise direction by the turning of cam 818 to carry out the selective raising action. Spring 208 exerts a force on rack 210 by means of gear 209, and the energy is distributed to each of the links 825, 828, 831 and 834 by means of drive arm 212 and levers 810 and 811, which are connected to the arm. Links 825, 828, 831 and 834 which are connected to selector levers 819, 820, 821 and 822, respectively, react on cam lever 817 to turn cam lever 817 in the counterclockwise direction. Engaged with the ends of selector levers 820, 821, and 822, as shown in FIGS. 13 and 16, are corresponding latch levers 835, 836, and 837. Therefore selector lever 820 can be engaged by latch lever 835 to prevent the counterclockwise motion of selector lever 82, or latch lever 835 can be moved out of the path of motion of selector lever 820 and selector lever 820 will then follow the complete path of motion of cam lever 817. When a code element for control of the rising of the type-bar and which is transmitted from the control mechanism is in the 0 state, selector lever 820 is engaged and blocked and when the code element is in the 1 state, selector lever 820 is free to move. Selector lever 821 is similarly controlled by latch lever 836, and selector lever 822 is similarly controlled by latch lever 837, and each is prevented from moving by the latch lever when the code element is in the 0 state, and when the code element is in the 1 state, levers 821 and 822 follow cam lever 817 and carry out a rotational motion. Since selector lever 819 is not engaged by a corresponding latch lever, it follows the complete course of movement of cam lever 817 for every rotation of cam 818.

FIG. 13 is a diagrammatic plan view; therefore, driving arm 212 and levers 810 and 811 are shown in the same plane. Actually, they are laid one on top of the other as shown in FIG. 16. Therefore, points 827 and 824 are one on top of the other at the same position. Points 833 and 830 also are on top of one another. The same relationship exists for connecting points 826 and points 829 and 832.

There is thus formed a floating type adding mechanism which comprises lever 810 and 811 and driving arm 212, and the amount of displacement and the individual turning motion of the four selector levers 819, 820, 821 and 822 is transferred to points 824, 827, 830 and 833 of floating type adding mechanism through links 825, 828, 831 and 834, and the displacements are compounded by a certain ratio, which depends on the configuration of the floating type adding mechanism, and are magnified, and rack 210 is operated by driving arm 212 to perform the selective raising of the type-bar. If only selector lever 819 operates, then point 824 of lever 811 moves, with point 830 as the center thereof, the same distance as point 823, and this is magnified at point 814, and since point 815 on driving cam 212 is joined to point 814, driving arm 212 is displaced with point 813 as the center thereof, and the movement is magnified at the end of driving arm 212 and is transmitted to rack 210. The displacement of end 826 of selector lever 820 is transmitted to the point 827, and the

displacement of point 812 due to movement of lever 810 around point 833 as a center resulting therefrom is transferred to point 813 on driving arm 212. In this case, driving arm 212 will turn around point 815 as the center, and the displacement will be transmitted to rack 210. Similarly, the displacement of selector lever 821 is transferred to driving arm 212 through lever 811, and the displacement of selector lever 822 is transferred to driving arm 212 through lever 810.

The total amount of displacement of selector lever 819 and the amount of displacement of levers 820, 821 and 822 to engage them with the corresponding latch levers, when transferred to the end of driving arm 212, is sufficient to move the rack 210 a distance sufficient to raise the type-bar 1 from the type bar case to place the uppermost character of the 8 characters arranged on type-bar 1 at the printing position opposite the platen. That is when each of selector levers 820, 821 and 822 is engaged with the corresponding latch lever due to code elements Xb_1 , Xb_2 and Yb_1 , as shown in FIG. 5, being in the 0 state so that the full motion of levers 820, 821 and 822 is prevented, the uppermost character (O, Su, Kin on the type pieces in FIG. 5) is moved to the printing position. Selector lever 820 is controlled according to the state of code element Xb_1 of FIG. 5, and the difference in distance of movement of the type-bar between the 0 state and the 1 state is, as shown in FIG. 5, equivalent to the spacing of two adjacent characters. Selector lever 821 is controlled according to the state of code element Xb_2 and a change of state moves the type-bar two spaces; and selector lever 822 is controlled according to the state of code element Yb_1 and moves the type bar four spaces. Accordingly, when only selector lever 820 is in the 1 state, the second character from the top (1, 7 and Go as shown on the type bars in FIG. 5), will be moved to the printing position. When only selector element 821 is in the 1 state the third character from the top (2, No, Hyaku in the type bars of FIG. 5) is moved to the printing position. When only selector element 822 is in the 1 state the fifth character from the top (4, Se, 0 on the type bars of FIG. 5) is moved to the printing position. When selector levers 820 and 822 are both in the 1 state, the sixth character from the top (5, To, Roku on the type bars of FIG. 5) is moved to the printing position. When selector levers 820, 821 and 822 are all in the 1 state the bottom character (7, Mi, San on the type bar of FIG. 5) is moved to the printing position. When selector levers 820 and 821 are in the 1 state the fourth character from the top (3, Ma, Ni on the type bars of FIG. 5) is moved to the printing position. When selector levers 821 and 822 are the 1 state the seventh character from the top (6, Ha, Sen on the type bars of FIG. 5) is moved to the printing position.

Since connection point 211 between the end of driving arm 212 and rack 210 is fixed on the path of motion of rack 210 (i.e. on a straight line), errors introduced in the positions of selected characters arising from the changes in the amount of the effective lengths of links 825, 828, 831, and 834 stemming from the amounts of leftward and rightward displacement of the ends of these links caused by the turning of driving arm 212 can be made negligibly small by making the length of each of these links sufficiently great. Manufacturing errors in the dimensions of driving arm 212, levers 810 and 811, selector levers 819, 820, 821, and 822 which

comprise the adding mechanism can be corrected by adjusting positions of the connections therebetween.

Cam 818 has a shape such that after completion of the raising of the type bar and printing the characters and the return of the type-bar into the type bar case, when cam 818 turns further, it turns cam 817 in the clockwise direction and after selector levers 835, 836, and 837, turns slightly in the counterclockwise, and comes to a stop position in a position in which levers 820, 821, and 822 have their movement blocked by latch levers 835, 836, and 837. By this action latch levers 835, 836, and 837 will also carry out storage of the code elements which control the raising of selected type-bars. As indicated by FIGS. 13 and 16, the apparatus has a plurality of memory bars 331 - 337 corresponding to code elements and forming part of a storage mechanism to be described hereinafter. Memory bar 331 is connected by link 841 to latch lever 835, memory bar 332 is connected by link 842 to latch lever 836. Memory bar 333 is connected by link 843 to latch lever 837. These memory bars are for control when the apparatus is in the normal state. A link 844 is also connected to one of a further plurality of bars connected to further memory bars to be described hereinafter. Link 844 is for control when the apparatus is in the Chinese character operational state, and is connected to latch lever 837.

Arm 865 of type bail 860 acts on links 841 and 842, and when link 841 and 842 are in a position corresponding to the 1 state, the arm of bail 864 acts to cause links 841 and 842 to actuate latch levers 835 and 836, and latch lever 835 and latch lever 836 are actuated to disengage from selector lever 820 and selector lever 821 and are held in this condition until cam 818 completes one complete revolution. When the apparatus is in the normal operational state, arm 864 of type bail 860 also acts on link 843, and when the apparatus is in the Chinese character operational state, the arm 864 acts on link 844. When link 843 or link 844 is in a position corresponding to the 1 state and when it is acted on by a bail arm, the action is transmitted to latch lever 837, the selector lever 822 and latch lever 837 are disengaged, and the condition is maintained until cam 818 completes one revolution. The operation of type bail 860 will be described later. Latch levers 835, 836 and 837 are shown in FIG. 13 as individual levers, but in practice they can be a series of links and levers as shown in FIG. 16.

Cams 845 and 846 on shaft 856, shown in FIGS. 13 and 17, are the cams used for spacing during printing operations. In the Chinese character operational state the printing of each character requires two spaces on the platen; that is the space required will be twice that required for printing a character in the normal operational state. Cam 845, as shown in FIG. 17, acts on lever 849 through cam lever 847 and link 848, and acts immediately after every printing action regardless of whether the operational state is the Chinese character operational state or the normal operational state. Lever 849 is connected to the clutch cam mechanism (not shown) which performs spacing of the platen, and the movement of lever 849 starts the operation of said clutch cam mechanism. Cam 846 is a cam that, at the time the spacing action started by lever 845 is complete, starts operation of lever 849 again by acting through cam lever 450 and link 851. However, link 851 engages lever 849 only when lever 852 is in the Chinese

character position, whereas in the normal operational state link 851 is pushed down by lever 852, and the movement of link 851 does not effect lever 849. Lever 852 is actuated by arm 866 of type bail 860, and in the normal operational state it pushes lever 852 counter-clockwise and pushes link 851 down. Contrariwise, in the Chinese character operational state, link 851 is left in the raised position, and each time the printing action is carried out twice. In the normal operational state only cam 845 is effective and for each printing action the spacing action takes place only once.

Cam 853 on shaft 856, shown only in FIG. 13, is a kind of safety device and it stops the revolution of shaft 153 that drives clutch cams that drive the type bar case. Shaft 153 is shown in FIGS. 10, 12, 19 and 20. The stopping of shaft 153 occurs at the time the raising of the type bar starts. As shown in FIG. 13 cam 853 acts on lever 854 which in turn moves link 855 to actuate clutch lever 468 as shown in FIG. 20. Clutch disc 469 is fixed on shaft 153 as shown in FIG. 20, and toothed driven clutch member 470 which moves in the axial direction of shaft 153 is coupled in a guide groove of clutch disc 469. Action of clutch lever 468 controls the coupling of clutch disc 469 and driven clutch member 470 with driving clutch 471. Driving clutch member 471 is fixed on a hollow shaft which rotates around shaft 153, and gears 472 and 473 on the hollow shaft are connected to a motor or a drive means (not shown) to receive power therefrom.

Lever 468 disengages driven clutch member 470 from driving clutch member 471 by means of the movement of link 855 driven by cam 853, and shaft 153 stops rotating. Lever 468 is maintained at the disengaged position by latch lever 467. Therefore, as will be described later, immediately before starting the movement of the type bar case for positioning to print the next character, latch lever 467 must be disengaged from clutch lever 468 by the action of the controller 465. When lever 468 is freed, driven clutch member 470 will mesh with driving clutch member 471 by the action of a spring (not shown), and the rotation of shaft 153 will start.

In FIG. 13, the cams 805, 802, 226, 818, 846, 845, 853, which control raising of the type bar, adjustment of printing pressure, starting of printing action, and rotation of shaft 153, are fixed on shaft 856. On the left end of shaft 856 is fixed a clutch disc mechanism 871 the connection of which with clutch case 873 is controlled by the action of stop lever 872. Clutch case 873 and gear 874 are connected to each other and rotate constantly around shaft 856, and gear 874 is driven from a motor (not shown) directly or by means of intermediate device. The command for raising the type-bar issued from the controller shown in FIG. 20 is, as shown in FIG. 13, transmitted by means 875, such as links, to stop lever 872, and when the stop lever is actuated, clutch disc mechanism 871 will be coupled with clutch case 873 and carry out one rotation of shaft 856 and the cams fixed on the shaft will be rotated.

Type bail 860, shown in FIG. 13 and FIG. 17, consists of arms 862, 863, 864, 865, 866, 867 and sleeve 868 each fixed on shaft 861. A groove in sleeve 868 has one end of lever 876 engaged therein, and the other end of lever 876 is engaged in a groove in sleeve 876a on shift bail shaft 107, and when shift bail shaft 107 moves left and right, respectively, in accordance with either the Chinese character or the normal operational state, type

bail 860 also moves left and right, being moved by lever 867, and takes a position corresponding to either the Chinese character or the normal operational state. In FIG. 17 the type bail is shown in the Chinese character operational state with the type bail 860 moved to the right, and in this position arm 866 will not act on lever 852, and arm 862 is positioned where it will not act on lever 243, and arm 864 is in a position where it acts on link 844. Arm 865 acts on links 841 and 842 and arm 863 acts on the link 246 in either position of the type bail. Arm 867 acts to rotate type bail 860, and as shown in FIGS. 13 and 20 lever 498 is actuated, its movement is transmitted to arm 867 by means of link 880, and type bail 860 will rotate, and arms 862, 863, 864 and 865 will carry out their respective operations.

FIGS. 19 and 20, which are the right and left halves, respectively, of a diagram, illustrate systematically and diagrammatically the selective control mechanism comprising first and second memory selector mechanisms and the storage mechanism. In teleprinters, means for storing codes and identifying function control codes and issuing signals or movements that control actions of the related mechanisms simultaneously is widely used, and this means is generally called the code bar mechanism. The code bar mechanism has memory elements corresponding to the code elements, and in order to identify the character code units, function code units and other code units simultaneously, function bars corresponding to special codes are provided among the stored codes, and said function bars carry out a special displacement to cause the related mechanisms to carry out their actions.

Referring to FIGS. 19 and 20, eight code bars 311 - 318 comprise a first memory selector mechanism, and they correspond to code elements $b_1 - b_8$ in FIG. 1, respectively. Similarly, eight code bars 321 - 328 form a secondary memory selector mechanism, and eight code bars 331 - 338 form a storage mechanism, each set of code bars corresponding to code elements $b_1 - b_8$ shown in FIG. 1.

In the first memory selector mechanism, function bars associated with code bars 311 - 318 are provided for the following function codes: A, B, C, D, E, F, SOH, STX, ETX, SOHc, HTXc, BEL, WRU, EOT, OTH, DLE, DLI, DLA, SR, Ys, Y_{10} , Y_{01} , Y_2 , Y_1 . These function bars are used to identify code units and initiate related actions. In the second memory selector mechanism having code bars 321 - 328, function bars are provided for the following function codes: X_1 , X_{01} , X_{10} , SIO, OR, DEL, OO, SPI, TFC, SUBO, SION, SUB, Ton, Tof, SO, SI, BS, SP, SIOS, HT, FF, LF, VT Pon, Pof. These function bars are also used to identify code units and initiate related actions.

In order to feed code units into the first and second memory selector mechanisms and identify function bars and initiate related actions, five clutch cam mechanisms 400, 410, 430, 450, and 460 are provided, and are mounted on a main shaft 407 which rotates at a constant rate to perform a series of control actions every time a code is received.

A gear 466 is mounted on main shaft 407 and is driven by motor (not shown) or some other drive means at a constant rate of rotation.

Clutch cam mechanisms 400, 410, 430, 450, 460 are provided, respectively, with clutch cases 401, 411, 431, 451, 461, and clutch disc mechanisms 402, 412, 432,

452, 462, and stop levers 405, 417, 439, 456, 464, respectively, assembled into rapid frictional clutch mechanisms which are conventionally used in teleprinters. The clutch cases are fixed on the main shaft 407 and are constantly rotating; the clutch disc mechanisms are coupled with the respective stop levers, and are normally stationary. When an outside impulse is received by a stop lever, the coupling between the stop lever and the corresponding clutch disc mechanism is disengaged, and the clutch disc mechanism is connected to the clutch case and rotates with main shaft 407. When the clutch mechanism is again engaged with the stop lever, the rotation of the clutch mechanism is stopped. A detailed description of the interior construction of the clutch disc mechanism will not be given herein since the mechanism is conventional.

In clutch cam mechanism 400, a code bar cam 403 and a trip cam 404 are fixed on clutch disc mechanism 402. Code bar cam 403 acts for receiving code elements for code bars 311 - 318 and 321 - 328 of the first memory selector mechanism and the second memory selector mechanism, respectively, and trip cam 404 acts to actuate stop lever 417 to engage clutch cam mechanism 410 so that it performs one rotation. Lines 409 and 406 indicate schematically a series of mechanisms by which the actions of cams 403 and 404 are transmitted. However, no description will be given of the details of the transmittal mechanisms since they can be conventional linkages or the like.

In clutch cam mechanism 410, a function bail cam 413, a function rod bail cam 414, a trip cam 415, and relay cam 416 are fixed on clutch disc mechanism 412 and rotate therewith. The action of function bail cam 413 is transmitted to a function bail 341 by means 418, and the action of function rod bail cam 414 is transmitted to function rod bail 342 by means 419. By the combination of the actions of these two cams, the functions of function bars A, B, C Y_2 , Y_1 of the first memory selector mechanism and the functions of the related mechanisms are initiated. The action of trip cam 415 is transmitted to cam lever 420, and by means of rods 422 and 423, which are mounted on cam lever 420, to clutch cam mechanisms 430 and 450, respectively, for starting these clutch cam mechanisms. The function of relay cam 416 is to disengage the connections between code bars 321 - 328 and the code bars 311 - 318 through means of 421 and rod reset bail 370.

In clutch cam mechanism 430, a function bail cam 433, a function rod bail cam 434, a latch release cam 435, a transfer cam 436, a function operating cam 437, and a trip cam 438 are fixed on the clutch disc mechanism 432 and rotate therewith. The action of function bail cam 433 is transmitted to function bail 391 by means 440, and the action of function rod bail cam 434 is transmitted to function pole bail 390 by means 441. By the combination of the cam actions of these two cams, the functions of function bars X_1 , X_{01} , X_{10} Pon, Pof of the second memory selector mechanism are initiated. Said functions are the same as those of the first memory selector mechanism. The function of latch release cam 435 is to restore, by means 442, the code bars 321 - 328 to an initial position. The function of transfer cam 436 is to transfer, by means 443, code units from the second memory selector mechanism to the storage mechanism. The action of function operating cam 437 is transmitted to the internal mechanism of the second memory selector mechanism by means

444, and carries out the platen carriage return and change-over between the Chinese character operational state and the normal operational state. The action of trip cam 438 is transmitted to cam lever 445 and it acts to start up clutch cam mechanisms 450 and 460 by means of trip rods 447 and 446 respectively.

Clutch cam mechanism 450 is for initiating type selecting and printing actions at the time the character codes are identified, and typing trip cams 453 and 454 and shift bail cam 455 are fixed on clutch disc mechanism 452 and rotate therewith. Stop lever 456, when the apparatus is in the Chinese character operational state, is acted on by trip rod 423, and when the apparatus is in the normal operational state is acted on by trip rod 447. It causes actuation of the clutch disc mechanism 452, and the clutch disc mechanism 252 and each of the cams 453, 454 and 455 carry out rotation. Typing trip cam 453 starts the mechanism which performs the action of raising type-bars and printing when the apparatus is in the normal operational state, and typing trip cam 454 starts the mechanism which performs the raising of the type and printing when the apparatus is in the Chinese character operational state. Shift bail cam 455 starts, by means 459, the mechanism for movement of the type bar case and at the same time transmits the code elements for controlling the distance the type bars are raised and the printing pressure to the mechanism for raising the type bars. When stop lever 456 acts, means 465 transmits that action to lever 467 to start the rotation of the driving shaft 153 for the type bar case moving mechanism.

When trip rod 446 actuates clutch disc mechanism 462, when the form control code units are identified, a cam 463 fixed on clutch cam mechanism 460 actuates, through means 479, a control mechanism associated with the platen, whether the device is in the Chinese character operational state or the normal operational state. The action of cam 463 is transmitted to the second memory selector mechanism by means 479. The action of trip rod 446 starts the action of a punching section under the control of the second memory selector mechanism.

The process of transfer of the code units received by the first and second memory selector mechanisms and their further transfer to the storage mechanism will now be described. FIGS. 21 and 22, which show specific mechanisms forming part of FIGS. 19 and 20 will be described in addition to FIGS. 19 and 20 to describe said mechanism. In FIG. 19 there is shown a receiving means 300 which is a receiving selector mechanism when the apparatus is a teleprinter and which is a multiwired code receiver mechanism when the apparatus is to be connected to a multiwired type tape reader or to other similar electronic or electric circuits. The code unit received by receiving means 300 is indicated by the displacement of respective code bar stop bars 301, 302 - 308 corresponding to the code elements. For each code unit received, receiving means 300 starts the action of clutch cam mechanism 400 by means 309.

Code bars 311 - 318 are each provided with ledges 319 and 320. A reset bar 408 which is actuated by code bar cam 403 through means 409, normally acts on ledges 319 of code bars 311 - 318 to keep code bars 311 - 318 at the extreme left hand position, and upon rotation of code bar cam 403 is turned counterclockwise to release the code bars 311 - 318. Code bars 311 - 318 are moved toward the right by the action of

springs 895. At this point, code bar 311 is paired with code bar stop bar 301, and when code bar stop bar 301, which corresponds to code element bi, is in a position corresponding to the 0 state, the end of code stop bar stop 301 will engage ledge 320 on code bar 311 and maintain code bar 311 at a position corresponding to the 0 state. When code bar stop bar 301 is in a position corresponding to the 1 state, code bar 311 moves toward right to a position corresponding to the 1 state without its movement being hindered. Code bars 312 - 318 and code bar stops 302 - 308 are paired with each other in the same manner.

Thus the code units received are represented by the positions of code bars 311 - 318 and are stored in the first memory selector mechanism. At the same time, clutch cam mechanism 410 is started by means of trip cam 404, and the identification action of the first memory selector mechanism will be performed. At the termination of the rotational motion of code bar cam 403, reset lever 408, having been acted on during this rotation through means 409, rotates clockwise, and returned code bars 311 - 318 to their normal extreme left hand positions.

Code bars 321 - 328 have engaged therewith, at their other ends, push rods 361 - 368 which are urged in a counterclockwise direction around studs 896 under the action of springs 898, and which are normally in contact with code bars 311 - 318. Push rods 361 - 368 which correspond to the respective code bars 311 - 318 which are changed to positions corresponding to the 1 state will be disengaged from normal contact with the code bars and turn further in the counterclockwise direction into the path of movement of bars among code bars 311 - 318 which have moved to 1 state positions. Therefore, the respective code bars among code bars 321 - 328 corresponding to code bars 311 - 318 which are in the 1 state positions will, when the code bars 311 - 318 are returned to their normal positions by means of reset bar 308 be pushed toward the left and will be moved into positions corresponding to the 1 state. Thus, the code elements stored in the first memory selector mechanism are transferred to the second memory selector mechanism and are represented therein by the positions of the code bars 321 - 328. The specific mechanism of FIG. 21 will be described in more detail hereinafter.

Each of the code bars 321 - 328 has a ledge 329 thereon which is engaged by one of a set of latches 371 - 378 to maintain the respective code bars 321 - 328 in the 1 state position, and even when code bars 311 - 318 start on the next code receiving action, the positions of bars 321 - 328 will be maintained by latches 371 - 378. At the time the action of the first memory selector mechanism is completed by means of the action of cam mechanism 410, clutch cam mechanism 430 starts, by the action trip cam 415, to start the action of the second memory selector mechanism.

When the code identification of the second memory selector mechanism is complete, the ends of latches 371 - 378 are disengaged from the ledges 329 by means of latch release cam 435 and means 442, described in more detail hereinafter, whereby those bars among bars 321 - 328 which have been at 1 state positions will be returned to 0 state positions by springs 498.

Just before the action of clutch cam mechanism 410 causes return of code bars 311 - 318 to their original positions at the end of one rotation of clutch cam

mechanism 410, rod reset bail 370 is acted on by release cam 416 to turn push rods 361 - 368 in the clockwise direction to remove them from the path of motion of code bars 311 - 318 and to engage push rods 361 - 368 with code bars 311 - 318 again after code bars 321 - 328 have returned to the 0 state positions. At this time the push rods which are associated with the code bars of code bars 311 - 318 which are in 1 state positions will move into the path of motion of the code bars. The timing is such that code bars 311 - 318 will return to their positions after completing moving appropriate push rods 361 - 368. The detailed structure of reset pawl 370 will be described hereinafter.

Open circles (O) at left end of code bars 311 - 318 of FIGS. 19 and 20 indicate that the left positions are 0 state positions, and the solid circles or dots at the right ends indicate that the right positions are 1 state positions. Similarly, with code bars 321 - 328 the 0 state positions at the right are indicated by open circles (O) and 1 state positions at the left are indicated by dots.

The function of transfer cam 436 is to initiate transfer of the code unit stored in code bars 321 - 328 to memory bars 331 - 338. That is, the action transfer cam 436 is transmitted to a transfer bail 260 by means 443. Transfer levers 261 - 268 and transfer bail cranks 251 - 258 are shown in a schematic way in FIG. 20, and certain of them are shown in FIG. 22 in a three dimensional view. The end of each transfer lever is coupled with one end of the corresponding transfer bail crank to act as a unit therewith. The transfer bail is normally in a position in which it is turned counterclockwise, and at this position, each transfer lever 261 - 268 has the lever end thereof pushed by part 269 of transfer bail 260, so that the ends of transfer bail cranks 251 - 258 engaging code bars 321 - 328 are maintained in position outside of the path of motion of code bars 321 - 328. When transfer cam 436 rotates with code bars 321 - 328 in either 0 state or 1 state positions in accordance with the code elements which they represent, transfer bail 260 will rotate clockwise, whereby transfer bail cranks 251 - 258 will turn so that ends 920 thereof move toward code bars 321 - 328, and transfer bail cranks 251 - 258 which correspond to code bars 321 - 328 which are in 0 state positions engage said code bars 321 - 328 and are held in engagement therewith; however, the ends of the transfer bail cranks corresponding to code bars 321 - 328 in 1 state positions are at locations past cutouts in the code bars, and said cranks will rotate toward the code bars, and transfer levers 261 - 268 corresponding thereto will then rotate freely in the clockwise direction. Push rods 271 - 278 are attached to the respective transfer levers at the lower ends 279 of the levers. Push rods 271 - 278 are always urged to rotate clockwise by the action of springs 932, and their right hand ends are in contact with memory bars 331 - 338. Details of the foregoing structure will also be described hereinafter.

During the clockwise rotation of transfer bail 260, transfer levers 261 - 268 will also tend to rotate clockwise; however, the transfer levers 261 - 268 corresponding to the code bars 321 - 328 which are in 0 state positions will be blocked and the right ends of the push rods corresponding thereto will be maintained in positions to contact with ledges 339 of memory bars 331 - 338. Only those transfer levers 261 - 268 corresponding to code bars 321 - 328 which are in 1 state

positions rotate freely, and the right ends of the push rods corresponding thereto will also move freely to the left and be rotated clockwise into abutting engagement with the ends 339 of memory bars 331 - 338. With the parts in this condition, when transfer bail 260 rotates counterclockwise when it returns to the normal position, push rods 271 - 278 attached to transfer levers 261 - 268 in 1 state positions, will push the memory bars 331 - 338 with which they are in abutting engagement to the right to place them in 1 state positions. Thus the code unit stored in code bars 321 - 328 is transferred to the memory bars 331 - 338.

When transfer bail 260 rotates clockwise, a part 270 thereof will push ends 280 of push rods 271 - 278 attached to transfer levers 261 - 268 and which are at 0 state positions because of the code bars in 0 state positions, and the push rods 271 - 278, which are pushed by transfer bail 260 will rotate clockwise freely and disengage from the ends 339 of corresponding memory bars 331 - 338, and said memory bars 331 - 338 will be moved to 0 state positions by the action of springs 938. Transfer levers 261 - 268 associated with code bars 321 - 328 which have in 1 state positions rotate clockwise freely, and notches in push rods 271 - 278 will engage over ends 339 of memory bars 331 - 338 without being influenced by lower end 270 at the end of movement of the transfer bail 260. Thus the code unit is cleared from the memory bars 331 - 338 by the action of transfer bail 260, and the next code unit is stored in memory bars 331 - 338.

In the subsequent sections the mechanism for identification of control codes in the first and second memory selector mechanisms and the auxiliary operations performed thereby are described.

The function bars in FIGS. 19 and 20 identified by A, B, C, D, E, F, SOH Y₂, Y₁ and X₁, X₀₁, X₁₀, Don, Pof are not limited to identifying these characters or codes as such, but they represent the functions of the mechanisms which are related to the function bars as will be more specifically described in connection with FIG. 24. The function bars and their rotating mechanisms in the first memory selector mechanism are actuated by the action of function bail 341 and function rod bail 342, and the second memory selector mechanism by the action of function bail 391 and function rod bail 390. FIGS. 19 and 20 illustrate schematically the conditions under which the function bars and the related mechanisms operate and the results thereof. Therefore, the action of such function bar and the result thereof will be described with reference to FIGS. 19 and 20.

As an example, function bar SOH will be described. The intersections of function bar SOH and code bar 311 and code bar 318 are marked with a solid circle ●, while the intersections of SOH and the other code bars 312 - 317 are marked with a O. This indicates that in order to select function bar SOH, the received code elements must be such as to move code bars 311 and 318 to the 1 state positions and code bars 312 - 317 to the 0 state positions, whereupon the function bar SOH is operated by the bail 341 and the action called for by code SOH is initiated. In the case of function bar Y₁, the intersections thereof with code bars 311, 312, and 318 are void or unmarked, the intersections with code bars 313, 315, and 317 are marked with a solid circle, ● and its intersections with code bars 314 and 316 are marked with a O. This signifies that when the received code units are such as to move code bars 313, 315, and

317 to the 1 state positions, and code bars 314 and 316 to the 0 state positions, function bar Y₁ can be actuated, and the action called for by said code will be initiated whether code bars 311, 312, and 318 are in 1 state positions or in 0 state positions. Thus the various function bars will be actuated in response to receipt of corresponding code units for the different functions.

As another example, function bar A will be described. In this case all intersections of function bar A and code bars 311 - 318 are marked with Δ. This means that they are associated with an addressing code and are generally assigned to a character code, but since the code can be different depending on where it is used it is marked with Δ. However they can be marked either with a solid circle or O or not marked at all, depending on the place and condition under which they are used.

Referring again to function bar SOH, function bar SOH and further code bar 343 are tied together as indicated by "✓". This indicates that when function bar SOH is indicated by a received code unit and is then actuated, bar 343 moves to the left. Similarly function bar STX and bar 343 are tied together as indicated by "↗". This indicates that when function bar STX is indicated by a received code unit and is actuated, bar 343 returns to the right. The intersection of function bar DLE and bar 344 is tied together in a manner as indicated by both ✓ and ↗. This indicates that when function bar DLE is indicated by a received code unit and actuated, bar 344 shifts first to the left and remains in that position until the next code unit is indicated and then it returns to the right. That is, the action of function bar DLE is to adapt the next incoming code unit to perform a special function.

These symbols are used for all function bars and code bars and for further code bars 343, 344, 345, 346, 347, 348, 386, 387, 388, and 389 in the first and second memory selector mechanisms. Further code bars 343, 344 ... 389 are all in the 0 state position when they are shifted to the right, and are all in the 1 state position when they are shifted to the left and each such bar is marked with a corresponding O and a solid circle at the appropriate end. If function bar Y₁ is again taken as an example, when the received code elements are such that code bars 313, 315, and 317 are in 1 state positions and code bars 314 and 316 are in 0 state positions, and only when bar 344 is in the 0 state position and bar 345 is in the 1 state position is function bar Y₁ operable to perform its function. The aforementioned relationship holds for all function bars and code bars and further code bars 343 389.

Next, the individual function bars will be described. The intersections of each function bar and code bars 311 - 318 and code bars 321 - 328 are marked with symbols designating an ISO code unit as shown in FIG. 1.

In FIG. 19 function code SOH means "start of heading". When the received code unit indicates this function bar and it is actuated, bar 343 shifts to the 1 state position making possible the selection of any one of function bars A, B, C, D, E, and F. The functions of all the function bars A, B, C, D, E and F is to make possible own station reception when they are actuated, and since it is possible to identify them with a single code unit or identify them with more than two code units, or since simultaneous addressing to several stations may be possible, they are shown as multi-bars. In FIG. 19

function bars C, D, E and F are single addressing codes, and when they are indicated and actuated, bar 345 will move to the 1 state position, and the apparatus is placed in the own-station reception operational state. Function bar B when indicated and actuated makes bar 346 move to the 1 state position. Function bar A can be actuated only when bar 346 is in the 1 state, and when function bar A is actuated, selection bar 345 is moved to the 1 state position to establish the own-station reception operational state. Bar 346 is returned to the 0 state position when function bar A is operated. Accordingly when the code unit for code A is received after the code unit for code B has been received as an address code, the own station reception operational state is established, thus illustrating the function of a combination of code characters A and B as an address code. Similarly, a combination of more than three code characters to indicate an identification mechanism corresponding to the address codes is possible.

Function bar STX is used to indicate the end of the address and the start of the text, and when it is indicated by a received code unit and actuated, it returns bar 343 to the 0 state position. Function bar ETX is used to indicate the end of the text, and the function bar therefor, by returning bar 345 to the 0 state position, terminates the own-station reception operational state. Bar 347 and function bars SOHc and ETXc perform what is called start and check functions to check that the SOH code unit and ETX code unit are being received alternately. Thus bar 347 is moved to the 1 state position by function bar ETX and is returned to the 0 state position by function bar SOH. Therefore, if the code unit for ETX is received, and is not followed not by the code unit for SOH, but is followed by the code unit for ETX again, the function bar ETXc is indicated and actuated. Similarly when the code unit for SOH is received, followed again by the code unit for SOH due to the failure of code unit ETX to arrive, function bar SOHc is actuated. When function bar ETXc or SOHc is actuated contact points 350 or contact points 349, operated by the function bars, are closed and an alarm or some other signal is actuated.

Bar 345 is returned to the 0 state position by the operation of function bar SOH. When 345 is in the 0 state position, function bar OTH is actuated for each received code unit and actuates bar 356. The actuation of bar 356 acts on rod 357 and trip rod 422. Rod 357 is connected to reset bar 408 and is actuated for each code unit received. However, only when it is acted on by bar 356 does it act on rod reset bail 370 to disengage push rods 361 - 368 from code bars 311 - 318 to prevent the transfer of the code stored in code bars 311 - 318 to code bars 321 - 328. When trip rod 422 is acted on by bar 356, it moves out of its position for actuating stop lever 439 and clutch mechanism 430 is not started. Therefore, when bar 345 is in the 0 state position, all actions down stream of the second memory selector mechanism will not be performed, and also in the first memory selector mechanism, the function bars SP, Ys, Y₁₀, Y₀₁, Y₂, Y₁ can not be actuated. Thus, the teleprinter receives the code units which are transmitted through a circuit and monitors them to check whether they contain an address that makes them acceptable to the station.

Function bar BEL is indicated by a signal code unit and initiates a signal by setting off a bell 351 or by clos-

ing contact points 352, and corresponds to code ENG of FIG. 1. Function bar WRU is indicated by a code unit to initiate the answer-back function. It is assumed in FIG. 19 that the answer-back function is initiated electrically and said function bar is illustrated as operating contacts 353. Code EOT is a control code indicating the end of a series of transmissions and it has no bearing on the text; so function bar EOT which is indicated and actuated by the code unit is shown as actuating contacts 354 to operate a signal. When function bars BEL, WRU, and EOT are operated, each acts on bar 356 to prevent, as forementioned, the transfer of code units to the second memory selector mechanism and to prevent actions of the mechanisms subsequent to the second memory selector mechanism.

Function bars DLE, DLI, DLA interrupt communication by controlling the terminal station from the central exchange and the control code is formed by pairing the code unit for DLE with a character code unit which immediately follows it. Accordingly, function bar DLE moves bar 344 into the 1 state position where it prevents the actuation of function bars A, B, C, D, E, F and SP, Y_s, Y₁₀, Y₀₁, Y₂ and Y₁ in response to the character code unit which is received immediately following the DLE code unit. Also by actuating bar 356 it prevents the start up and the transfer of code units to the second memory selector mechanism. Function bar DLI is operated in response to the code unit which immediately follows the code unit for DLE, and by affecting bar 356 prevents the start up and the transfer of code units to the second memory selector mechanism. Function bar DLA is indicated and actuated when the received code unit next after the code unit for DLE corresponds to the code unit for DLA, and closes contact 355 to generate a signal. If necessary several contacts 355 can be operated by function bar DLA.

Since function bars SP, Y_s, Y₁₀, Y₀₁, Y₂, and Y₁ operate only to exert effects on the printing activity in the Chinese character operational state, they will be described with the description of the second memory selector mechanism shown in FIGS. 19 and 20.

In the second memory selector mechanism, when function bar Ton is actuated bar 387 is shifted thereby to the 1 state position, and when function bar Tof is actuated bar 387 returns to the 0 state position. When 387 is in the 0 state position it blocks movement of the function bars for type selection, controlling the printing mechanism, form control, and switching operational states. When bar 387 is in the 1 state position, actuation of the function bars for all these functions become possible. As indicated in FIG. 20, function bar Ton is actuated when the code units for STX and DC₂ are received and the memory bars moved to the appropriate positions, and function bar Tof is actuated when code unit DC₄ is received. When function bar SUB is actuated, bar 386 is shifted to the 1 state position and changes the operational state of the apparatus to the Chinese character operational state. When function bar SIOC is actuated, bar 389 is shifted to the 1 state position so that if the next code unit received is a proper one, function bars SION and SIOS can be actuated. When function bar SION is actuated, bar 386 is returned to the 0 state position and restores the apparatus to the normal operational state. When bars 386 and 387 are both in the 1 state positions, function bars X₁, X₀₁, X₁₀, SIO, SUBC can be actuated, if the appropriate

code unit is received, to perform corresponding functions.

The functions of function bars X_1 , X_{01} , X_{10} , and SIO are to indicate receipt of an X code unit in the Chinese character operational state, and bar 388 is shifted to the 1 state position to prevent the actuation of function bars X_1 , X_{01} , and X_{10} when the next code unit, which is a Y code unit, is received. Function bar X_1 acts on bar 380, and function bars X_{01} and X_{10} act on bar 381, and function bar SIO acts on bar 382. However, when function bar Y_1 or function bar Y_2 in the first memory selector mechanism is actuated, it acts on bar 380 only if function bar X_1 is actuated, and the sum of the actions causes bar 380 to produce an output. Therefore only when an X code unit is indicated as having been received by the second memory selector mechanism and a Y code unit is indicated as having been received by the first memory selector mechanism, does the action of bar 380 take place.

Similarly, when function bar X_{01} or X_{10} is actuated, bar 381 will be acted on, but will produce an output only if either function bar Y_{01} or Y_{10} is actuated. Furthermore, when function bar SIO is actuated bar 382 is acted on but again it produces an output only when function bar Y_s in the first memory selector mechanism is actuated.

The output of bar 380 is transmitted through rod 246 (see also FIGS. 13 and 15) to the type bar raising and printing mechanism to the means to decrease the force necessary for the printing action for printing special symbols which require specially small pressure. As shown in FIG. 19, when either bar 381 or bar 382 produces an output, it is transmitted to trip rod 423, and by moving the end of trip rod 423 to a position to act on stop lever 456, signals the receipt of a Y code unit in the first memory selection mechanism, and when trip cam 415 operates, clutch cam mechanism 450 is operated. When both bar 386 and bar 387 are in the Chinese character operational state or the 1 state position, function bar SUBC is actuated for every code unit which is received and acts on bar 385 which disengages trip rod 447 from stop bar 456 so that the action of trip cam 438 is not exerted on clutch cam mechanism 450. Thus in the Chinese character operational state, trip rod 423 actuates clutch cam mechanism 450 only on receipt of alternate code units; that is each time a Y code unit is received in the first memory selector mechanism. Function bar SP is actuated in response to receipt of a code unit for code SP (spacing) in FIG. 1, and bar 348 is kept in the 1 state position until the next code unit is received. Therefore, when this SP code unit is transferred to the second memory selector mechanism, the function bar X_{01} will be in condition to be actuated. However, because bar 348 is in the 1 state position, the movement of function bar X_{01} is blocked. Thus the function of the SP code when an X code unit is being handled is prevented by bar 348.

Function bars X_{01} and Y_{01} are each responsive to code units in which element b_8 is 1 and element b_7 is 0, and they are able to be actuated upon receipt of code units for each of the 32 codes shown in columns 2 and 3 of FIG. 1. Function bar X_{01} , however, is blocked by means of bar 348 when the code unit for SP in the zero row of column 2 is received, but function bar Y_{01} can be actuated when the code unit for SP is received, and although SP is not used as an X code in the Chinese character operational state, it can be used as a Y code.

Function bar X_1 can be actuated in response to code units in which b_8 and b_7 are 1 and b_4 and b_6 are 0. It is thus actuated in response to code units for characters D, E, F, and G and T, U, V, and W in FIG. 1; and similarly function bar Y_1 can be actuated in response to code units for characters T, U, V, and W in FIG. 1.

Function bars SIO and SIOC act in response to the code unit for either code SI or CO, and function bars SION and Y_s are both in 0 state positions. Accordingly, they act in response to code units all codes in the O column and in the second column of FIG. 1. Function bar SIOS also acts in response to code units for all codes in the second column of FIG. 1. The purpose of this is to move the type bar case to a specific position for changing back from the Chinese character operational state to the normal operational state, and for that purpose, an SI code unit or an SO code is used as an X code unit to select a code character in the O column or in the second column of FIG. 1 as the Y code unit, and after carrying out the displacement of the type bar case in the same manner as when the apparatus is in the Chinese character operational state, the type bar raising and printing action are carried out in the normal state according to the code unit which has been received. Essentially, the action is performed by the combination of either an SI code unit or an SO code unit with the SP code unit. However two successive SI code units or two successive SO code units can be used, and as long as the Y code unit is for a code character in the O column and in the 2nd column, there will be no hindrance to the movements of the type bar case. When function bars X_{01} or X_{10} and Y_{01} or Y_{10} act to move bar 382 and when function bars SIO and Y_s act to move bar 382, clutch cam mechanism 450 is actuated to turn through one revolution, as aforementioned, by trip rod 423 acting on stop lever 456.

By the action of clutch cam mechanism 450, the action of cam 455 is transmitted to rods 394 and 395 by means of rod 459, and rod 394 acts on arm 185 on bail shaft 107 (FIG. 12) to start the aforementioned type bar case driving mechanism to carry out the movement of the type bar case. Rod 395 acts on bar 498 and transmits through rod 880 to the type bail 860 (FIGS. 13 and 17) the necessary movement of the type bail in connection with the type selective raising mechanism. When function bar SIOC is actuated and the apparatus is changed from the Chinese character operational state to the normal operational state, rod 395 will be disengaged from bar 498 by the movement of function bar SIOC which is coupled thereto. Thus the movement of the type bar case will be carried out but the action of the type bail 860 will not be carried out. Cam 453 acts by means 457 on rod 392 which does not have any effect when the apparatus is in the Chinese character operational state, but when the apparatus is in the normal operational state, it acts on lever 499 under the control of lever 396 and link 398, and the action of lever 499 is, as described above in connection with FIG. 13, transmitted by rod 875 to clutch cam mechanism 871 - 873 to initiate the operation of the type raising and printing mechanism.

The action of cam 454 is transmitted by means 458 to rod 393 which, when the apparatus is in the Chinese character operational state, initiates the operation of the type raising and printing mechanism by its action on bar 499 in the same manner as described above. In the normal operational state rod 393 is moved by

means of lever 396 and link 398 so that it does not act on lever 499.

When function bar SION is actuated following the actuation of function bar SIOC, lever 396 is turned counterclockwise thereby and is held at that position by means, such as a latch, 397. When lever 396 is held in the actuated position, link 398 is moved to the right and moves rod 393 from the position in which it acts on lever 499 and moves rod 392 to the position in which it acts on lever 499. However, at this point, cam 453 has already completed its action but cam 454 has not started its action so that when the Chinese character operational state is changed to the normal operational state, lever 499 will not operate and thus the type raising and printing mechanism will not operate, and only the positioning of the type bar case takes place. Link 398 also acts on rod 383 and moves it from a position where it acts on lever 188 to a position where it acts on lever 189. Rod 383 acts at the same time as 384 in response to the action of cam 437, and when it acts on lever 188, it moves operating arms 173 (see FIG. 12) to positions corresponding to the Chinese character operational state, and when it acts on lever 189 it moves operating arms 174 to positions corresponding to the normal operational state.

When bar 386 is returned to the 0 state position by the actuation of function bar SION, the normal operational state is established; function bars X_1 , X_{01} , X_{10} , SIO and SIOC become nonoperative, and since function bar SUBC also becomes nonoperative, trip rod 423 is actuated by cam 416 but does not act on stop lever 456. When character code units are being received, operation of clutch cam mechanism 450 is started for every code unit by trip rod 447 acting on stop lever 456 when clutch cam mechanism 430 operates. When function bars DEL, OO and SPI are actuated, bar 385, having been acted on by said function bars, moves trip rod 447 so that it does not act on stop lever 456, and the action of clutch cam mechanism 450 is stopped. Function bar SPI is actuated in response to receipt of the code unit for code SP, and each such function bar prevents type raising and printing action.

Function bar CR is actuated by cam 437 and in response to the code unit for code CR (carriage return) and acts on the aforementioned rod 384 to move it to a position where it acts on lever 500 and starts the carriage return operation.

Function bar BS is actuated in response to the code unit for code BC (back spacing), and it and function bars HT, FF, LF, and VT act on rods 511, 513, 514, 515, and 516, respectively. The actions of these rods are further transmitted under the control of cam 463 and rod 479 to transmitting means 521, 523, 524, 525, and 526 to carry out the functions of platen carriage return, horizontal tab (HT), forward movement (FF) of the platen, line forward (LF), and vertical tab (VT), respectively. Function bars CR, BS, HT, FF, LF, and VT operate both when the apparatus is in the Chinese character operational state and the normal operational state. No description of the operation of the platen will be given herein, since it is not relevant to the invention.

Function bar SP is actuated in response to receipt of a code unit for code SP. However, when the apparatus is in the Chinese character operational state, only when bar 388 is in the 0 state position is function bar SP actuated, and when bar 388 is in the 1 state position, the

code unit for SP is used as a character code unit so that function bar SP is not actuated. Function bar SIOS is actuated when function bar SION is actuated to change the apparatus from the Chinese character operational state to the normal operation state. It is actuated and carries out functions only for the character codes of the 0 row and the second row of FIG. 1, or the codes in the second row which are SP codes. Both function bars SP and SIOS move rod 512 which transmits this action to transmitting means 522 under control of cam 463 and rod 479. Means 522 actuates the mechanism which performs the spacing operations of the platen carriage. The platen carriage is not described herein.

Function bars SI and SO are actuated in response to code units for the SI code and the SO code, respectively, and when function bar SI is actuated lever 905 is turned and held in position by latch 904, and when function bar SO is actuated latch 904 is turned and lever 905 is returned to its initial position. The movement of lever 905 is transmitted to bar 480. Bars 481, 482, 483, 484, 485, and 486 are linked with code bars 321, 322, 323, 324, 325 and 327, respectively, and operating together transmit the necessary code elements from the second memory selector mechanism to the mechanism for moving the type bar case and to the type raising mechanism of the aforementioned type bar case. Function bar TFC is actuated every time bar 387 is in the 0 state position and acts on bar 385 to prevent cam 450 from being actuated by acting on rod 447 as described above.

Function bar Pon is actuated in response to a code unit for code DC_3 , and function bar Pof is actuated in response to a code unit for code DC_4 . When function bar Pof is actuated lever 488 is turned and moves rod 489 from the position in which it acts on bar 490, and lever 488 is held at that position by latch 487. When function lever Pon is actuated, latch 487 is moved to release lever 488 which returns to its initial position, and rod 489 resumes the position where it can act on lever 490. Rod 489 is connected with trip rod 446 and operates every time cam 438 operates, and when rod 489 acts on lever 490, that action is transmitted to the punching section by means of lever 490.

The transmission of code elements to the punching section is by levers 281 - 288 from memory bars 331 - 338. However the action of the punching section is not relevant to the invention, so its description will not be included herein.

FIG. 21 and FIG. 22 are isometric projections of parts of the apparatus of FIG. 19 and FIG. 20 respectively, showing in detail the mechanism by which the code elements represented by code bar stop bars 301 - 308 in FIGS. 19 and 20 are transferred to memory bars 331 - 338 through code bars 321 - 328.

As shown in FIG. 21, when the code elements to which code bar stop bar 301 corresponds is 1 code bar 301 is moved by receiving mechanism 300 as described in connection with FIG. 19. Code bar stop bar 301 is turned clockwise by bar 881 shown in FIG. 21 and moves to a position in which it will engage ledge 320 to block the movement of code bar 311 toward the right at a point in which the code bar 311 is in the 1 state position. When the stop bar 301 is not moved into the path of code bar 311, code bar 311 moves to a position in which it is in the 0 state position. Similar relations exist between code bar stop bars 301 - 308 and code bars 312 - 318. Reset lever 408 shown diagram-

matically in FIG. 19 is shown in FIG. 21 as being made of parts 890, 891, 892, 893 and 894. Arms 891 and 892 are fixed on shaft 893, and bar 890 is supported at the ends of the arms, and arm 894 is fixed on the lower end of shaft 893. Link 409 of FIG. 19 is also shown in FIG. 21 connected at the end of arm 894, and the other end of link 409 is acted on by cam 403 as indicated in FIG. 19. The action is transmitted to arm 894 which rotates shaft 893. Under the normal condition, bar 890 holds the code bars 311 - 318 in the extreme left hand positions by engagement with ledges 319 thereon. The parts of lever 408 rotate clockwise in response to the rotation of cam 403 to free the code bars 311 - 318 for movement toward the right. Therefore, code bars 311 - 318 can be acted on by the respective springs 895 attached thereto. The code bars among code bars 311 - 318 corresponding code bar stop bar 301 - 308 which are in 0 state positions are blocked and stopped at 0 state positions, while the remainder are pulled to the right to 1 state positions. During the period in which code bars 301 - 308 are in 0 state and 1 state positions, certain function elements will be actuated, as will be described hereinafter, and after completion of the actions the parts forming reset lever 408 will be turned counterclockwise by means of cam 403 and bar 890 engages code bars 311 - 318 and transfers them to the left hand position.

Code bars 321 - 328 are connected to their respective push rods 361 - 368 by studs 896 at the ends of the code bars 321 - 328 around which the push rods are pivoted. Springs 898 turn the respective push rods 361 - 368 counterclockwise and at the same time pull the code bars 321 - 328 toward the right. Code bars 321 - 328 will normally be in the 0 state position when the ends of the slots 899 in the code bars are against post 900. End parts 901 on push rods 361 - 368 are normally engaged with code bars 311 - 318 under the tension of spring 898. When code bars 311 - 318 are in 0 state positions, the ends 901 of push rods 361 - 368 bear against the top of projections 369 on code bars 311 - 318, but when certain code bars among code bars 311 - 318 change to the 1 state positions, end parts 901 of push rods 361 - 368 will engage the sides of projections 369 on code bars 311 - 318, and these push rods 361 - 368 corresponding to the code bars among code bars 311 - 318 in the 1 state positions, when they are pushed to the left, will push code bars 321 - 328 connected to them to the left to 1 state positions. The code bars among code bars 321 - 328 which are thus moved are maintained in the 1 state positions by latches 371 - 378.

Latch bail 379 shown schematically in FIG. 19 is comprised of bail bar 906, arms 907 and 908, shaft 909, and arm 910. Arms 907 and 908 are fixed on shaft 909, arm 910 is fixed at lower end of arm 909, and bail bar 906 is supported on the ends of arms 907 and 908 and rotates about shaft 909 as an axis. Link 442 is connected to the end of arm 910, and the other end of link 442, as shown in FIG. 19, is acted on by cam 435 to rotate latch bail 379. Shaft 909 also serves as an axis about which latches 371 - 378 are mounted for rotation. Latches 371 - 378 have springs 911 connected thereto tending to turn them clockwise, and when they are acted on by the latch bail 379, they are turned counterclockwise and are disengaged from code bars 321 - 328 and allow return code bars 321 - 328 to be returned to 0 state positions by springs 898.

Reset bail 370 indicated diagrammatically in FIG. 19 is comprised of rod 912, arms 913 and 914, shaft 915, and arm 916, as shown in FIG. 21. Arms 913 and 914 are fixed on shaft 915, arm 916 is fixed to the lower end of shaft 915. Rod 912 is supported by the ends of arms 913 and 914. Pole reset bail 370 is rotated about shaft 915 by link 421 connected with the end of arm 916, which in turn is acted on by cam 416 as indicated in FIG. 19. Rod 912 engages push rods 361 - 368 and moves ends 901 out of engagement from the sides of projections 369 on code bars 311 - 318, and permits the code bars 321 - 328 to move to the 0 state positions by disengaging them from those of code bars 311 - 318 which are in the 0 positions.

FIG. 22 shows the structure for transfer of code units from code bars 321 - 328 to memory bars 331 - 338. At the left end of each code bar 321 - 328 is projection 399, and transfer bell cranks 251 - 258 are mounted on shaft 918 adjacent projections 399. Transfer bell cranks 251 - 258 have springs 919 connected thereto tending to turn the bell cranks in the counterclockwise direction. The ends 920, when code bars 321 - 328 are in 0 state positions to the right, are contacted with the tops of projections 399, and when code bars 321 - 328 are in 1 state positions to the left, turn further in the counterclockwise direction and engage the sides of projections 399. At the end of each of the transfer bell cranks 251 - 258 is a notch 921 in which is engaged the upper end 922 of the corresponding transfer levers 261 - 268. Transfer bail 260 shown diagrammatically in FIG. 20, comprises bail 923, shaft 924, and arm 925. Bail 923 is fixed on shaft 924 at positions 926 and 927, and bail edges 269 and 270 which are inclined with respect to shaft 924 act on transfer levers 261 - 268 and push rods 271 - 278, respectively. Transfer levers 261 - 268 are mounted in respective grooves 928 in shaft 924, and rotate around shaft 924. Arm 925 is mounted at one end of shaft 924, and the end of the arm is connected with link 443. In FIG. 20 link 443 is indicated as simply engaged by cam 436, but actually it is coupled to cam 436 by means of lever 930 and link 931, as shown in FIG. 22.

Cam 436 normally acts on link 443 to turn transfer bail 260 counterclockwise, and when the lower parts of transfer levers 261 - 268 are moved to the right, the upper parts of transfer levers 261 - 268 turn transfer bell cranks 251 - 258 clockwise. Thus ends 920 are disengaged from projections 399 on code bars 321 - 328. Code bars 321 - 328 can then be moved to 0 state and 1 state positions corresponding to the code elements. After code bars 321 - 328 are moved to 0 state and 1 state positions corresponding to a new code unit, transfer bail 260 is turned clockwise by the action of cam 436 on link 443, and since the transfer bail cranks 251 - 258 turn counterclockwise due to the motion of transfer bail 260, the bail cranks among transfer bail cranks 251 - 258 which correspond with those code bars among code bars 321 - 328 which are in 0 state positions will be blocked by the engagement of ends 920 with projections 399, while the bail cranks among transfer bail cranks 251 - 258 which correspond to the code bars in the 1 state positions will turn sufficiently so that the ends 920 pass to the right of projection 399.

Push rods 271 - 278 are connected to the lower ends of transfer levers 261 - 268 and are urged clockwise by means of springs 932 connected between them and the

respective transfer levers 261 - 268. As transfer bail 260 rotates clockwise, the left ends 280 of push rods 271 - 278 are pushed counterclockwise by the edge 270 of transfer bail 260. Since movement of the transfer levers 261 - 268 is blocked by engagement of bail cranks 251 - 258 with code bars 321 - 328 which are in the 0 state positions, the right ends 933 of push rods 271 - 278 are released from engagement with memory bars 331 - 338, and these memory bars are returned to the left, or 0 state positions by means of springs 938. Then when the transfer bars among transfer bars 261 - 268 which correspond to the code bars among code bars 321 - 328 which are moved to the 1 state positions follow the rotational motion of transfer bail 260 so that left ends 280 of corresponding push rods 271 - 278 are not blocked by transfer bail 260. Therefore the right end parts of these push rods among push rods 271 - 278 move clockwise and engage edges 339 of the corresponding memory bars 331 - 338. Then when transfer bail 260 again rotates counter-clockwise due to the normal action of cam 436, the memory bars which are engaged by push rods among push rods 271 - 278, that is only memory bars among memory bars 331 - 338 which correspond to code bars among code bars 321 - 328 which are in 1 state positions, are pushed to the right into 1 state positions. These positions are maintained until displacement of code bars 321 - 328 in response to the next code unit takes place.

Bar 179 and bar 180 shown in FIG. 12 are designated by two numbers, depending on the configuration of the corresponding bell cranks 175 and 176; however, memory bars 331 - 338 are extended into bars 179 and 180 to transmit the code elements to the parts 175 and 176. Although in FIGS. 13, 19 and 20 memory bars 331 - 338 and fingers 99, 100, 94, 95, 103, 104, 96 and 97 are shown as simply being connected for the transmittal of the state of the code elements as represented by the positions of memory bars 331 - 338 to fingers 99, 100, 94, 95, 1-3, 104, 96 and 97, in actual practice the connection is through a mechanism comprised of bell crank 175 or 176 and the mechanism 179 or 180 shown in FIG. 12. FIGS. 19 and 20 do not show the specific mechanisms.

The transmittal of code elements from memory bar 331 to finger 841 is by means of bell crank 935 as shown in FIG. 22, and the same mechanisms connect memory bars 332 and 333 and fingers 842 and 843, as shown diagrammatically in FIG. 13. The ends of fingers 841, 842 and 843 are shown in FIG. 17 and their actions are as described in conjunction with FIG. 17. The connections shown in FIG. 20 from the code bars 321 - 325 and from code bar 327 to bars 481 - 486 are direct connections and cause bars 481 - 486 to move in the same way as the corresponding code bars. The actual mechanism connecting these bars is as shown in FIG. 22. Bar 481 is connected to lever 937 which is engaged in notch 936 in code bar 321, so that bar 481 moves at the same time code bar 321 moves. The connection between code bars 322, 323, 324, 325, and 327 and the respective bars 482 - 486 is similar to that between code bar 321 and bar 480. The type of connection used between memory bar 331 and finger 841 can also be for the connection between bar 481 and finger 844. The mechanism for connecting bar 482 and finger 90, bar 483 and finger 91, bar 484 and finger 89, bar 485 and finger 93, and bar 486 and finger 92, respec-

tively, is the same as the mechanism of 179 or the mechanism of 180 as shown in FIG. 12.

FIG. 23 is an isometric projection of the mechanism for actuating the function bars for function codes A, B, C, D, E, F, SOH Y_2 , Y_1 and X_1 , X_{01} , X_{10} , Pon and Pof when the positions of the code bars 311 - 318 and 321 - 328 shown in FIG. 19 and 20 are such as to represent a code unit for one such function. One set of parts is comprised of function bar 940, function rod 941, function lever 942, and latch bar 943 as shown in FIG. 23. In FIG. 24 these four parts and function bail 341, function rod bail 342, and end views of the corresponding code bars and their relationships are shown.

The action of one such set, for example for function bar SOH, will be described. Function bar 940 moves in the direction of its length in the left and the right direction in the figure with guide cam 944 and shaft 945 acting as guides therefor, and it is urged toward the left by spring 946. To the left of function bar 940 are positioned in order from the top, bars 347, 345, 344, 343, and code bars 311 - 318 and these bars, as shown in FIGS. 21 and 23 are provided with notches 959 in the edge facing each function bar 940 to select the respective function bar 940. Projections 947 - 958 on the left end of function bar 940 are positioned relative to bars 347, 345, 344, 343, and code bars 311 - 318 and are bent, as shown in FIGS. 21 and 23, corresponding to the code elements in the code unit for the function code which the function bar represents, and only when the code bars are positioned to align notches with the projections 947 - 958 on function bar 940 can the projections move into the notches of the code bars and allow the function bar to move. Otherwise the movement is prevented by the solid portions of the code bars or bars which are positioned so as not to have notches in positions which correspond to the code elements. This system is often used in teleprinters so the details thereof will not be given herein.

Normally, function bail 341 engages function bar 940 to push it to the right, and when the state positions of code bars 311 - 318 corresponding to a received code unit are established, all the functions bars are moved against the code bars and bars. Only function bars 940 having all the projections 947 - 954 corresponding with the notches in the code bars 311 - 318 and bars 347, 345, 344, 343 move toward the code bars and the other function bars are blocked when the projections hit the edges of the code bars and other bars. Function rod 941 rotates around shaft 960, and since it is held in contact with right upper end 962 of function bar 940 by means of spring 961, when function bar 940 moves to left and into the notches in the code bars and other bars, projection 963 on function rod 941 contacts with upper right end 962 of function bar 940. Then when all function bars 940 are pushed to the right by function bail 341, function rod 941 which is engaged with function bar 940 is also pushed to the right against the force of spring 961, and bent part 964 (FIG. 23) on function lever 942, which is engaged by part of function rod 941, moves function lever 942 to the right, and function lever 942 turns, against the force of spring 965, clockwise about shaft 945.

When function lever 942 rotates, part 966 thereof engages latch bar 943, and parts 967, 968, 969 and 975 on function lever 942 act on mechanisms engaged thereby. Function rod bail 342 moves up and down under control of cam 414. When it is moved upward,

it pushes up projection 963 on function rod 941 which is engaged with function bar 940 and has been pushed to the right by function bail 341, and releases it from projection 962 on function bar 940. When latch bar 943 is not actuated, it returns function lever 942 to the initial condition. When it is moved downward, it pushes down projection 970 on latch bar 943 and releases the engagement with projection 966 on function lever 942 and function lever 942 returns to its former condition. Function bail 341 and function rod bail 342, shown in FIG. 18 (which will be explained later) and FIG. 19, are actuated by the actions of cam 413 and cam 414 transmitted thereto during one revolution of clutch cam mechanism 410. The movement of function bars 940 into engagement with the code bars is carried out by the springs 946 and leftward movement of the function bail 341 within the 1st half revolution of cam 413. In the 2nd half of the revolution, function bar 940 is moved and held in the position to the right. Function rod bail 342 acts on function rod 941 toward the end of the revolution of cam 414, and at about the midpoint of that revolution it acts on latch bar 943. Consequently, when function bar 940 matches the notches in the code bars, function rod 941 which is engaged by function bar 940 returns to its initial position at the end of one revolution of clutch cam mechanism 410, but latch bar 943 which is connected to function lever 942 will resume the connection even when it is disengaged therefrom during the course of revolution of said cam mechanism before function rod 941 returns to its former condition. Therefore function lever 942 maintains its condition until latch bar 943 is disengaged about mid-way in the revolution of cam mechanism 410. When function lever 942 carries out its function solely by its displacement, such as closing of contact points or ringing of a bell, there is no necessity to maintain its position until the next function code unit is set by the positions of the code bars, so the corresponding latch bar 943 is not necessary and it can be omitted. Some latch bars 943 do not have a projection 970 on the right side, and some have a projection 971 bent leftward or bent rightward on the lower part thereof, as shown in FIG. 23. In this case, latch bar 943 is not acted on by rod bail 342, but is engaged by projection 969 on the lower part of an adjacent function lever to the left (or the right) thereof, as shown in FIG. 23 and is turned clockwise and disengaged from function lever 942. Consequently, the return of function lever 942 to its initial position is effected by the actuation of an adjacent function lever on the left (or on the right) thereof. The function bar which acts on bent projection 971 on the lower part of latch bar 943 need not be immediately adjacent thereto but can be the one next to the adjacent function bar. In this case, in order to prevent lower ledge 969 of the adjacent function lever from exerting its effect, this adjacent function lever has this projection removed therefrom. Projection 967 on function lever 942 is bent leftward and extended as shown in FIG. 23 and is normally engaged with projection 974 of the adjacent function lever on the left thereof and blocks action thereof. When there is no need to block this action, a function lever 942 which has no projection 967 is used.

When projection 967 is provided on function lever 942, and only when said function lever is in the actuated position can the adjacent function lever on the left thereof be actuated. Lower projection 968 is for trans-

mitting the action of function lever to other mechanisms, and such actions will be separately described.

When function bar 940 shown in FIG. 23 carries out the function according to SOH in FIG. 19, the upper end 975 of the corresponding function lever 942 is engaged with link 976, and when function lever 942 is actuated and is held in position by latch bar 943, link 976 is pulled by end 975 of function lever 942 and moves bar 343 to the left by means of bell crank 978 and spring 980. Bar 343 moves along the elongated grooves located at both ends thereof being guided by posts 979. When function lever 942 is not actuated, function lever spring 965 acts on link 976 through end 975 of function lever 942 and pushes the groove in bar 343 against post 979 by means of bell crank 978 as shown in FIG. 23 to move bar 343 to the 0 state position. When function lever 942 is actuated and maintained in this state by latch lever 943, link 976 is pulled to the right, and bell crank 978 is turned clockwise, and bar 343 is displaced to the left and the groove is pushed against post 979 from the right side to place bar 343 in the 1 state position. Further movement of function lever 942 causes bell crank 978 to turn further, stretching spring 980 further by the corresponding amount to make sure bar 343 is in the right position. Movement of bar 343 from the 1 state to the 0 state position is effected when the function lever 942 for the function bar STX which is adjacent to bar 343 as shown in FIG. 19, is actuated, and lower projection 969 of lever 942 acts on the extended part of latch bar 943 and the function lever 942 for the function bar SOH returns to its initial condition. Similarly, bar 344 is moved to the 1 state position when the function lever 942 for the function bar DLE (subsequently, instead of 942, a code indicating a function is added and expressed as function lever DLE) is actuated, and when latch bar 943 for the function lever for the DLE function bar is acted on by function rod bail 342 at the time the next function code is received, bar 344 returns to the 0 state position.

In FIG. 19, bar 343 is shown as moving to the 1 state position when the code unit for any of the function levers — A, C, D, E, and F is received. In this case the lower ends 968 of function levers for the A, C, D, E, and F and other function bars act on common bar 981 as shown in FIG. 25. Common bar 981 turns around shaft 982, and projection 983 at the left end thereof engages common function lever 984. Common function lever 984 is connected to bar 345 by means of link 977 in the same manner as is function lever 942 in FIG. 23, to move bar 345 to the 1 state position. Latch lever 943 which latches common function lever 984 of FIG. 25 has an extended part 971 acted on by the function lever for function bar SOH or ETX, as shown in FIG. 19, and thus common function lever 984 is returned to its normal position and bar 345 returns to the 0 state position. Bar 346 shown in FIG. 19 is connected only to function lever B and function lever A, which are adjacent to each other. The arrangement is actually as shown in FIG. 23 and 24, in which projection 974 on function bar 940 is acted on by projection 967 on function lever 942 for function bar B, and when function lever is held by latch lever 943 the action of the adjacent function lever for function bar A is possible. When the function lever for function bar A is actuated, it acts on latch lever 943 of function bar B to return the function lever for function bar B to its initial position. The function lever for function bar A acts on common bar 981, as

shown in FIG. 25. In the case of bar 347, since the function lever for the function bar SOH and the function lever for function bar ETX are, as shown in FIG. 19, placed on opposite sides of function bar STX, the function lever for function bar ETX moves bar 347 to the 1 state position, as has been described above, and the function lever for function bar SOH acts on latch bar 943 for function bar ETX and returns bar 347 to the 0 state position. The action of the function lever for function bar SP on bar 348 is the same as the action of the function lever for function bar DLE on bar 344 as described above.

In FIG. 19 bar 386 is moved to the 1 state position by the action of the function lever for function bar SUB and is returned to the 0 state position by action of the function lever for function bar SION, and bar 387 is moved to the 1 state position by the function lever for function bar Ton and is returned to the 0 state position by the function lever for function bar Tof. The operations are carried out by the same type of mechanism as moves bar 343 as described above. The movement of bar 388 in FIG. 19 is by any of the function levers for function bars X_{01} , X_{10} and SIO. Said operations are carried out by the same type of mechanism as described in connection with the function lever for function bar DLE of FIG. 19, and in order that movement can be given to any of the three function levers for function bars X_{01} , X_{10} and SIO, a special link such as link 985, shown in FIG. 23, which is connected to the three function levers is used.

Bar 389 shown in FIG. 20, is also actuated by the function lever for the function bar SIOC in the same manner as the function lever for the function bar DLE in FIG. 19 actuates bar 344.

FIG. 18 shows the structure of the connection between function bail 341 and cam 413, and the structure of the connection between function rod bail 342 and cam 414. Cam 413 and cam 414 are eccentric cams and, as diagrammatically shown in FIG. 19, they are part of mechanism 410, being rotated together, and links 986 and 987 are connected thereto to change the motion into a reciprocating motion. One end of link 986 is pivoted to arm 989 on rocker shaft 988. Rocker shaft 988 is supported by bearings at its ends 990 and 991, and the shaft performs a reciprocating angular motion in response to the movement of link 986. Arms 992 and 993 which are mounted on the two ends of rocker shaft 988 are connected to function bail lever 996 by means of links 994 and 995. Function bail lever 996 turns about its lower ends 997 and 998, and function bail 341 is secured to the top thereof by three screws in order to make possible accurate adjustment of its position. Function bail 341 is positioned so as to push the lower ends of all function bars 940 (only one is shown in FIG. 18) to the right. The structure of the respective connections between arms 992 and 993 and their respective links 994 and 995 has been designed such that, during the reciprocating angular motion of rocker shaft 988, said connection amplifies the displacement from the central point during the half rotation in the clockwise direction. Therefore, function bail lever 996 acts, during the reciprocating angular motion of the rocker shaft, most effectively during the clockwise displacement from the central point, and during about half the rotation of cam 413, allows the function bar 940 to move to the left from its right-most position to fit function bar 940 into the notches in code bars 311

- 318 (FIG. 24), after which function bail 341 function bar 940 moves function bars 940 to the right and thus completes the movement thereof.

The action of cam 414 is transmitted to arm 1040 through link 987 engaged with cam 414. Arm 1040 is fixed on shaft 1041 and it carries out a reciprocating angular motion and reciprocates shaft 1041 around the axis thereof. At both ends of shaft 1041 are fixed arms 1042 (only one end is shown in FIG. 28), and linked to the ends of arms 1042 are links 1044 (only one link is shown) which moves upward and downward. Function rod bail 342 is supported by links 1044 and moves upward and downward in the grooves in guides 1046 at both ends thereof (only one end is shown). Thus one rotational motion of eccentric cam 414 is converted into one cycle of upward motion and downward motion of function rod bail 342. In FIG. 18 only one function rod 941 is shown in association with function rod bail 342. Function rod bail 344, as shown in FIG. 24, in its upward motion acts on any function rod 941 engaged therewith, and in its downward motion acts on projections 970 of latch levers 943. The relationships and the operations of the mechanisms connecting function bail 391, function rod bail 390 and cams 433 and 434 shown in FIG. 19 are the same as for cams 413 and 414 and bails 341 and 342. Contacts 349, 350, 352, 353, 354 and 355, shown in FIG. 19, are actuated by the upper end (FIG. 24) of function lever 942 of function bar SOHc and other appropriate function levers for other function bars. The bell mechanism of FIG. 19 is not described in detail herein.

The action of bar 356 when the function levers for function bars BEL, WRU, EOT, OTH, DLE, DLI of FIG. 19 act thereon is shown in FIG. 26. Bar 356 is supported by arms 1001 and 1002. Arms 1001 and 1002 are fixed on sleeve 1003 to form a lever which is mounted for rotation about shaft 1004. Function lever 942 is for one of the function bars BEL, WRU, EOT, OTH, DLE, and DLI. Regardless of which of those function levers 942 is actuated, the lower part 968 acts on bar 356 and turns it counterclockwise with arms 1001 and 1002. The lower end of arm 1001 is pivotally connected to link 1005. Link 1005 has a long slot 1007 therein in which post 1006 is slidably positioned to guide link 1005. Link 1005 transmits the motion of arm 1001 to rod 422 to turn it clockwise and disengage rod 422 and stop lever 439. Cam 415 is part of the cam mechanism 410 of FIG. 19, and during one rotational motion it acts on cam lever 420. Cam lever 420 is fixed on shaft 1008, and turns shaft 1008 about its axis. The motion of lever 420 is also transmitted to lever 1001 which is fixed on shaft 1008.

Rod 422 has attached to the end thereof a stud 1012 which is mounted on one end of lever 1011. Therefore, when cam lever 420 turns counterclockwise around the axis of shaft 1008, rod 422 moves with cam lever 420, and is normally engaged with stop lever 439. Stop lever 439 is thereby disengaged from its engagement with clutch disc 432. When clutch disc 432 is freed from stop lever 439, it carries out one rotational motion of cam mechanism 430 as described in connection with FIG. 19. However, when rod 422 has been acted on by link 1005 and is disengaged from stop lever 439, the displacement of cam 415 will not be transmitted to stop lever 439; so that clutch cam mechanism 430 does not operate.

A link 1013 is pivotally connected to the bottom end of arm 1002, and when arm 1002 turns counterclockwise, link 1013 moves to the right to engage bar 357 with arm 1015. Arm 1015 is fixed on shaft 893 of reset lever 408 of FIG. 21 and it is moved by the action of cam 403 and transmits the movement to bar 357. The movement of bar 357 is transmitted by crank 1014 to the arm 916 on the lower end of rod reset bail 370 (FIG. 21). By this action push rods 361 - 368 are disengaged from code bars 311 - 318. Thus only one of the function levers 942 of the function bars BEL, WRU, EOT, OTH, DLE, and DL1 will act on bar 356 and prevent starting of cam mechanism 430, and the transfer of the code elements which are stored in code bars 311 - 318 to code bars 321 - 328 also will not occur.

Lever 1010 in FIG. 27 is rotated on shaft 1008 when cam 415 rotates. Stud 1009 on the end of lever 1010 has rod 423 pivotally mounted thereon, and spring 1009a normally urges rod 423 toward lever 1016, but normally it is kept out of engagement therewith by link 1017. However, when link 1017 moves to the left, rod 423 is engaged with lever 1016, and the movement generated by cam 415 is transmitted to lever 1016. Lever 1016 is coupled to arm 1018 on shaft 1019 having arm 1020 on the other end thereof engaging stop lever 456 and urging it into engagement with clutch disc 452. Movement of lever 1016 thus disengages stop lever 456 from clutch disc 452. The rightward movement of link 1017 occurs when a Y code unit is received when the apparatus is in the Chinese character operational state. Thus the starting of clutch cam mechanism 450 is by rotation of cam 415.

In FIG. 27 cam 438 is for moving rod 447 which is attached to stud 1021 mounted on cam lever 455 in accordance with the rotational motion of lever 445 about shaft 1022 by means of cam lever 445. Lever 445 is fixed on shaft 1022 and stop lever 456 is rotatable on shaft 1022. Normally, rod 447 is engaged with stop lever 456, and upon the rotation of cam 438 actuates clutch mechanism 450 by every rotation of cam 438, as diagrammatically shown in FIG. 20. However, when link 1023 moves to the right the rod 447 and stop lever 456 are disengaged and the clutch cam mechanism 450 is not operated. When the apparatus is in the Chinese character operational state, link 1023 moves to the right at the receipt of very code unit, in the manner just described, and when the apparatus is in the normal operational state, it is moved every time the code unit is one which does not require a printing operation. In this way cam mechanism 450 is prevented from operating and no printing action takes place. For this purpose, the left end of link 1023 is pivotally connected with the lower end of bar 385, which is actually in the form of a lever, and bar 385 is actuated by a function lever 942 (only one is shown in FIG. 27) for any one of the function bars DEL, OO, SP1, TFC, SUBC.

Link 1017 is connected to the top end of lever 1024 which turns on shaft 1025. Rotatably mounted on shaft 1025 are three pair of levers 1031 and 1032, 1033 and 1034, and 1035 and 1036. The lower ends of levers 1031 and 1032 are mutually connected by bar 380 as shown in FIG. 27. The top part of lever 1031 is acted on to turn it counterclockwise by lower part 968 of the function lever 942 for either function bar Y_1 or Y_2 of FIG. 19 (In FIG. 27 only the lower part 968 of one of the function levers is shown.) Similarly, lever 1032 is turned counterclockwise when function lever 942 cor-

responding to function bar X_1 of FIG. 19 is acted on. When either lever 1031 or lever 1032 turns, center point 1038 of bar 380 moves one-half the distance, and when both lever 1031 and lever 1032 turn together, center point 1038 of bar 380 moves a distance equivalent to the full movement of the levers, and the movement is transmitted to rod 246 which is pivotally connected to center point 1038. In FIG. 15 and 17 the other end of rod 246 is shown, and the manner in which it controls printing pressure has already been described.

Lever 1033 and lever 1034 in FIG. 27 are connected by bar 381 and lever 1035 and lever 1036 are connected by bar 382 in the same manner as are levers 1031 and 1032. Lever 1033 is turned by the function lever 942 which corresponds to either function bar Y_{01} or Y_{10} , and lever 1034 is turned by the function lever 942 corresponding to function bar X_{01} or X_{10} . Lever 1035 and lever 1036 are turned by the action of the function levers corresponding to function bars Y_s and SIO , respectively. Only when levers 1033 and 1034 move together does the center point of the bar 381 move lever 1024. Only when levers 1035 and 1036 move together does the center point of bar 382 move lever 1024. When lever 1024 is moved by bar 381 or bar 382, it turns counterclockwise, and by pulling link 1017 to the leftward, causes rod 423 to engage lever 1016 as described above.

Cam lever 445 which is actuated by cam 438 is fixed on shaft 1022 as has been described, and the action of cam lever 445 is transmitted by shaft 1022. Stop lever 464 which controls clutch cam mechanism 460, as shown in FIG. 20 is mounted on shaft 1022 in the same manner as lever 445. Stop lever 464 is not shown in FIG. 27; however, its association with clutch disc 462 is similar to the association of stop lever 456 with disc 452. The arm for rod 489, as shown in FIG. 20, for starting a punching mechanism is mounted on shaft 1022, although the detailed description thereof has been omitted herefrom.

When function bar SIOC in FIG. 20 is actuated, the lower end 968 of the function lever thereof turns lever 1050 counterclockwise, as shown in FIG. 28, and turns bell crank 1051 which is engaged by lever 1050 clockwise about shaft 1026. The movement of bell crank 1051 raises the left end of push rod 395. The right end of push rod 395 is pivotally connected to cam lever 459 which is actuated by cam 455, and the left end thereof corresponds to 880 shown in FIG. 17. Lever 498 is shown in FIG. 20 for convenience, since push rod 395 in actual practice acts directly on arm 867 shown in FIG. 17. Consequently, when the function lever for function bar SIOC is actuated, rod 395 is raised to a position where it cannot act on arm 867. Rod 394 is pivotally attached to cam lever 459 and each time cam 455 rotates, rod 394 acts on arm 185 of FIG. 12 and turns shaft 107.

As shown in FIG. 20 the actuation of the function lever for function bar SIOC makes it possible to actuate the function lever for the function bar SION in response to the next code unit received. FIG. 29 shows the lower part 968 of the function lever for the function bar SION and the lower part 968 of the function lever for the function bar SUB each acting on lever 396. The function lever for function bar SION turns lever 396 clockwise, the function lever for function bar SUB turns lever 396 counterclockwise, and spring 397

engaged with arm 1053 on shaft 396a on which lever 396 is mounted acts to urge lever 396 clockwise or counterclockwise depending on the position of lever 396. Means 397 shown in FIG. 20 as a latch and spring 397 of FIG. 39 differ in form, but they act the same. 5 Linked to arm 1053 is rod 398 which displaces rod 383 to the right and left, as shown in FIG. 12. Rod 383 is linked to cam lever 444 which is acted on by cam 437 as shown in FIG. 29. The relationship between the end of rod 383 and levers 188 and 189 has already been described in connection with FIG. 12. Rod 384 is pivotally connected to cam lever 444 and when the function lever for function bar CR is actuated, the lower end 968 thereof acts on lever 1054 to move rod 384 to a position where it acts on one end of lever 500, whereby the action of cam 437 is transmitted to lever 500. 15 Movement of lever 500 causes the return action of the carriage by conventional means, the description of which has been omitted.

In FIG. 29 the left end of lever 396 is coupled with the upper end of lever 1055 which rotates when lever 396 moves. Lever 1055 has rod 392 and rod 393 held in engagement therewith by a spring, and these rods move upward or downward to engage rod 392 or rod 393 with lever 499. In the Chinese character operational state, lever 396 is turned clockwise, rods 392 and 393 are raised, and rod 393 engages lever 499. In the normal operational state rod 392 engages lever 499. The movement of lever 499 is transmitted by link 875 to stop lever 872 shown in FIG. 13, and controls the operation of the type raising and printing mechanism. 20

FIG. 30 shows the mechanism which transmits the movement of the lower end 968 of the function lever for function bar SI. When the function lever for function bar SI is actuated, it is held in the actuated position by the corresponding latch bar 943 which is returned to its former position by the actuation of the function lever for function bar SO. Element 905 of FIG. 20 corresponds to the function lever for function bar SI and the element 904 corresponds to the latch bar 943 thereof. This function lever engages and rotates lever 1057 as shown in FIG. 30, and the movement is transmitted to finger 98 via link 1058, bell crank 1059, bar 480, and lever 1060. 25

FIG. 31 shows the mechanism for carrying out the functions of the function levers for function bars BS, SP, SIOS, HT, FF, LF, and VT. The lower ends 968 of these function levers, as shown by FIG. 31, engage the respective rods 511, 512, 513, 514, 515, and 516 and move them in response to the movements of the function levers. Rods 511 - 516 slide in grooves in shaft 517 and are urged to the left toward the function levers and shaft 517 by means of springs 518. Springs 518 also pull the rods counterclockwise and into contact with bail 519. Bail 519 normally engages the rods 511 - 516 at notched portions in which the ends of the rods are raised above the ends of bell cranks 531 - 536 to which rods 521 - 526 are connected. Bail 519 is linked to cam lever 479 by link 520 and upon being moved by cam 463 is turned clockwise to push the ends of rods 511 - 516 down. Among rods 511 - 516 only those which have been pushed to the right by the actuated function levers are moved down and against the ends of the corresponding levers 531 - 536 by the movement of bail 519. Rod 512 responds to the actuation of the function lever for either function bar SP or 30

SIOS. Levers 531 - 536 actuate parts of the platen mechanism through links and the like. The actions of the function levers for function bars Pof and Pon and their actions on rod 489 are similar to those described above and since they are not directly related to the present invention the description thereof will be omitted. 35

We claim:

1. In a teleprinter apparatus for typing or tape punching Roman alphabet characters, numbers, and symbols, and Chinese characters, and including a platen and means for spacing and rotating the platen and operating the tape punching means, the combination of code unit receiving means for receiving multi-element code units representing characters, symbols, numbers and functions to be carried out by the apparatus, a plurality of function means responsive to receipt of function code units for driving said apparatus for carrying out the functions represented by the function code units, conversion function means responsive to the receipt of conversion function code units for converting the apparatus from a normal operational state in which it prints Roman characters, numbers and symbols to a Chinese character operational state in which it prints Chinese characters and vice versa, one of said function means being spacing function means for driving said platen spacing means for every two code units received by said code unit receiving means and being coupled to said conversion function means for actuation when said apparatus is in the Chinese character operational state, printing means for printing characters, symbols and numbers on the platen, transmission means coupled to said code unit receiving means for receiving single code units and when they are for characters, numbers and symbols to be printed, transmitting them, further transmission means coupled to said code unit receiving means for receiving code units corresponding to characters, numbers and symbols, storing them and then transmitting them when the apparatus is in the normal operation state and when the apparatus is in the Chinese character operational state transmitting the second code unit of each pair directly to said printing means, one of said function means being normal printing function means coupled to said further transmission means for causing said further transmission means to store the code unit and transmit it to said printing means, one of said function means being Chinese character printing function means coupled to said further transmission means for coupling said further transmission means directly to said printing means, and one of said function means being tape punching function means for coupling the respective transmission means to the tape punching means. 40

2. The combination claimed in claim 1 in which said printing means comprises a type bar case having a plurality of type bars therein each having a plurality of raised type elements on a front face thereof and a rack on the back face thereof, said type bars being positioned vertically in said type bar case and being positioned in rows and columns in said type bar case with the type elements on the bars in each row being for characters represented by a set of code units different from the sets of code units for characters in the other rows and the type elements on the bars in each column being for characters represented by a set of code units different from the set of code units for characters in the other columns, and the position of each type ele- 45 50 55 60 65

ment on the individual bars being according to a set of code units different from the set of code units for the type elements in other positions on the individual bars, whereby the position of any individual character is according to a combination of code units which is different from the combination of code units for the other characters.

3. The combination as claimed in claim 2, in which the type bars having type thereon for the characters, numbers and symbols which are printed when the apparatus is in the normal state are grouped in one portion of said type case in order to reduce the amount of movement of the type bar case when the apparatus is in the normal operating state, said further transmission means having transmission parts for moving said type bar case in response to stored code units and having further transmission parts for moving said type bar case directly and switchover means for switching over from said transmission parts to the further transmission parts when switching from the normal operational state to the Chinese character operational state, whereby one printing action can be carried out in the time corresponding to receipt of one code unit when the apparatus is in the normal operational state, and one printing action can be carried out in the time corresponding to the receipt of two code units when the apparatus is in the Chinese character operational state.

4. The combination as claimed in claim 3, in which said printing means further comprises type bar case driving means for driving said type bar case in the directions of the rows and columns in response to the code units transmitted to the printing means by said transmission means for positioning the type bar case relative to the platen with the type bar containing the type element for a character beneath a printing position, type bar raising means including gears engaged with said racks on said type bars for raising the type bars out of the type bar case to a position at which the desired type element is opposite the position on the platen where it is to be printed, and type hammer means movable toward and away from said platen for driving said type bar against said platen when it is in the raised position for impressing the image of the type element on the platen.

5. The combination as claimed in claim 4, further comprising printing pressure altering means coupled to said type hammer means for adjusting the pressure with which said type hammer means strikes said type bar to one of a plurality of pressures, and a plurality of said function means equal in number to the number of pressures being coupled to said printing pressure altering means and being responsive, respectively, to the code units for different characters, symbols and numbers and actuating the printing pressure adjusting means depending on the printing pressure required to print the character, symbol or number for the code unit received.

6. The combination as claimed in claim 1 in which said transmission means comprises a first memory selector mechanism having means to receive and store therein a code unit received by said receiving means,

means for identifying code units which are to be transmitted and transmitting said code units, means for preventing transmission of code units which are not to be transmitted, and means for restoring the receiving and storing means to a condition to receive the next code unit, and said further transmission means comprises a second memory selector mechanism and a storage mechanism, said second memory selector mechanism having means for receiving a code unit from said first memory selector mechanism and identifying it as a code unit to be printed in the normal operational state or a code unit forming part of the pair of code units for a Chinese character and transmitting the code units to said storage mechanism and transmitting a second code unit of a pair of code units for a Chinese character directly to the printing mechanism, and said storage mechanism comprising means for storing and transmitting code units to said printing mechanism.

7. In a teleprinter apparatus for typing Roman alphabet characters, numbers, and symbols, and Chinese characters, and including a platen and means for spacing and rotating the platen, the combination of code unit receiving means for receiving multi-element code units representing characters, symbols, numbers and functions to be carried out by the apparatus, a plurality of function means responsive to receipt of function code units for driving said apparatus for carrying out the functions represented by the function code units, conversion function means responsive to the receipt of conversion function code units for converting the apparatus from a normal operational state in which it prints Roman characters, numbers and symbols to a Chinese character operational state in which it prints Chinese characters and vice versa, one of said function means being spacing function means for driving said platen spacing means for every two code units received by said code unit receiving means and being coupled to said conversion function means for actuation when said apparatus is in the Chinese character operational state, printing means for printing characters, symbols and numbers on the platen, transmission means coupled to said code unit receiving means for receiving single code units and when they are for characters, numbers and symbols to be printed, transmitting them, further transmission means coupled to said code unit receiving means for receiving code units corresponding to characters, numbers and symbols, storing them and then transmitting them when the apparatus is in the normal operation state and when the apparatus is in the Chinese character operational state transmitting the second code unit of each pair directly to said printing means, one of said function means being normal printing function means coupled to said further transmission means for causing said further transmission means to store the code unit and transmit it to said printing means, and one of said function means being Chinese character printing function means coupled to said further transmission means for coupling said further transmission means directly to said printing means.

* * * * *