



INTERNATIONAL APPLICATION PUBLISHED UNDER THE PATENT COOPERATION TREATY (PCT)

<p>(51) International Patent Classification <sup>6</sup> : <b>A62C 31/02</b></p>	<p><b>A1</b></p>	<p>(11) International Publication Number: <b>WO 00/12179</b> (43) International Publication Date: 9 March 2000 (09.03.00)</p>
<p>(21) International Application Number: PCT/US99/18816 (22) International Filing Date: 24 August 1999 (24.08.99)  (30) Priority Data: 60/098,142 27 August 1998 (27.08.98) US 09/179,097 27 October 1998 (27.10.98) US  (71) Applicant: BOWLES FLUIDICS CORPORATION [US/US]; P.O. Box 6300, Columbia, MD 21045-6300 (US). (72) Inventor: BOWER, Robert, E.; 6724 Sawyer Road, New Market, MD 21774 (US). (74) Agent: ZEGEER, Jim; 801 North Pitt Street, #108, Alexandria, VA 22314 (US).</p>		<p>(81) Designated States: AU, BR, CA, CN, IL, JP, KR, MX, European patent (AT, BE, CH, CY, DE, DK, ES, FI, FR, GB, GR, IE, IT, LU, MC, NL, PT, SE).  <b>Published</b> <i>With international search report.</i> <i>With amended claims.</i></p>

(54) Title: WATER BOTTLE WITH DRINKING AND SPRAY MODES

(57) Abstract

A liquid dispensing fitment for a liquid container (water bottle) having a mouth adapted to receive a fitment, comprising a skirt member (10) adapted for securement to the mouth of the liquid container, the skirt member (10) has first and second coaxial cylindrical members spaced to define a flow passage therebetween. The first of the cylindrical members (13) has a wall and a spaced detent element (25) on the wall to define closed, spray and drink positions. An actuating member has a liquid exit opening and a depending detent member with coating detent elements on the detent member coating with the spaced element at said closed, spray and drink positions. A spray forming device, such as a swirl cavity with openings for introducing water therein from the flow passage, causes a spray to issue to ambient through a single liquid outlet opening (22). For the drink position the spray forming device is disabled so as to allow a continuous liquid stream fluid to flow through the single liquid exit opening.

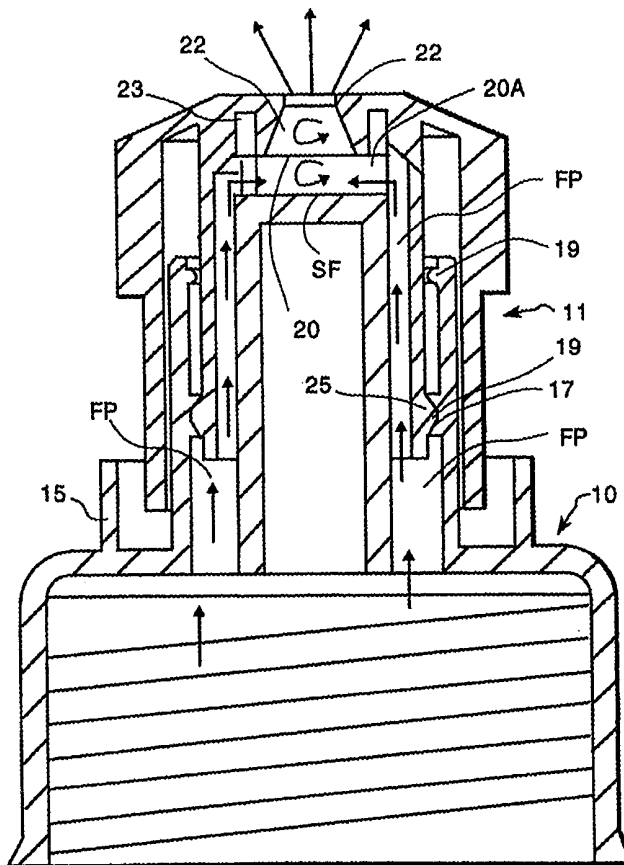

**FOR THE PURPOSES OF INFORMATION ONLY**

Codes used to identify States party to the PCT on the front pages of pamphlets publishing international applications under the PCT.

AL	Albania	ES	Spain	LS	Lesotho	SI	Slovenia
AM	Armenia	FI	Finland	LT	Lithuania	SK	Slovakia
AT	Austria	FR	France	LU	Luxembourg	SN	Senegal
AU	Australia	GA	Gabon	LV	Latvia	SZ	Swaziland
AZ	Azerbaijan	GB	United Kingdom	MC	Monaco	TD	Chad
BA	Bosnia and Herzegovina	GE	Georgia	MD	Republic of Moldova	TG	Togo
BB	Barbados	GH	Ghana	MG	Madagascar	TJ	Tajikistan
BE	Belgium	GN	Guinea	MK	The former Yugoslav Republic of Macedonia	TM	Turkmenistan
BF	Burkina Faso	GR	Greece			TR	Turkey
BG	Bulgaria	HU	Hungary	ML	Mali	TT	Trinidad and Tobago
BJ	Benin	IE	Ireland	MN	Mongolia	UA	Ukraine
BR	Brazil	IL	Israel	MR	Mauritania	UG	Uganda
BY	Belarus	IS	Iceland	MW	Malawi	US	United States of America
CA	Canada	IT	Italy	MX	Mexico	UZ	Uzbekistan
CF	Central African Republic	JP	Japan	NE	Niger	VN	Viet Nam
CG	Congo	KE	Kenya	NL	Netherlands	YU	Yugoslavia
CH	Switzerland	KG	Kyrgyzstan	NO	Norway	ZW	Zimbabwe
CI	Côte d'Ivoire	KP	Democratic People's Republic of Korea	NZ	New Zealand		
CM	Cameroon			PL	Poland		
CN	China	KR	Republic of Korea	PT	Portugal		
CU	Cuba	KZ	Kazakstan	RO	Romania		
CZ	Czech Republic	LC	Saint Lucia	RU	Russian Federation		
DE	Germany	LI	Liechtenstein	SD	Sudan		
DK	Denmark	LK	Sri Lanka	SE	Sweden		
EE	Estonia	LR	Liberia	SG	Singapore		

**WATER BOTTLE WITH DRINKING AND SPRAY MODES**

---

**REFERENCE TO RELATED APPLICATION**

This application is the subject of provisional application Serial No. 60/098,142 filed August 27, 1998 and entitled WATER BOTTLE WITH DRINKING AND SPRAY MODS which is  
5 incorporated herein.

**BACKGROUND OF THE INVENTION AND  
BRIEF DESCRIPTION OF THE INVENTION**

This invention relates to water bottles with drinking and spraying modes which enable the users to selectively  
10 spray water on their face or other parts of the body for cooling relief and for delivery of drinking water to a user's mouth.

Water delivery apparatus and devices are known in the art in which an adjustable nozzle which has a watering hose  
15 can produce either a spray or stream of water as disclosed in Porter U.S. Patent No. 4,815,635. Allemang U.S. Patent No. 5,326,124 discloses a bicycle water delivery apparatus in which water may be delivered to a sprayer or to a mouth and in which a diverting valve is selectively operable  
20 between first and second positions so as to form a path through which water may flow to be sprayed or to be directed to the mouth of the user. Steiner et al U.S.

Patent 5,788,125 discloses a sip and spray container having a separate spray and drink nozzles on a container. Squeeze bottles with sprayers and/or fluidic nozzles are known well in the patent literature. See Patents Nos. 4,052,002 and  
5 4,196,857, for example.

The present invention provides a personal water bottle delivery system which is simpler and less expensive to manufacture and to operate. It operates at low pressure and the spray quality is unaffected by pressure variation.  
10 The invention does not require external tubing which would result in a large pressure drop and therefore require more pumping. Preferably, the present invention does not require an internal feed tube, and the container does not have to be pressure-tight. The present invention is  
15 directed to a wide range of activities including cooling after exercise, cleaning, camping, cooking, etc.

In particular, the invention is directed to a water bottle fitment which is low in cost, easily used and is easily adapted to mass production.

20 According to the invention, the fitment is of the type that is a screw-on or snap-on fitment that incorporates a single valve element which is detented in (1) a closed position, (2) a spray position, and (3) a drink position, wherein water (or other fluid) is dispensed through a  
25 common opening for either the spray or the drink functions.

**DESCRIPTION OF THE DRAWINGS**

The above and other objects, advantages and features of the invention will become more apparent when considered with the accompanying drawings wherein:

5            Figures 1A and 1B are diagrammatic illustrations of a squeeze/water bottle incorporating the invention being used for spraying the user, the user's face or on the hair with cooling water, and Figure 1C is a diagrammatic illustration of the invention being utilized for drinking water from the  
10 water bottle wherein the water is directed to the user's mouth,

Figure 2 is an exploded isometric view of the fitment incorporating the invention,

15            Figure 3 is a sectional view of the water bottle fitment incorporating the invention in the closed position,

Figure 4 is a sectional view of the water bottle fitment incorporating the invention and the spray position,

Figure 5 is a sectional view of the water bottle fitment incorporating the invention in the drink position,

20            Figures 6A - 6F illustrate a further embodiment of the invention,

Figures 7A - 7F illustrate a further embodiment of the invention,

25            Figures 8A - 8F illustrate a further embodiment of the invention, and

Figures 9A - 9F illustrate a further embodiment of the invention.

(In Figures 6A - 9F, the letters A, C and E signify sectional views, and the letters B, D and F signify side elevational views.)

#### DETAILED DESCRIPTION OF THE INVENTION

5           As shown in Figures 1A, 1B and 1C, a single valve element fitment, which is detented in a closed position, spray position and a drink position, is capable of dispensing water through a common opening for the spray or drink functions in a sealed condition in a closed position.

10           In its most basic form, the invention comprises two molded components, namely, a skirted cap member 10 and an actuating member 11 having an exit aperture or outlet for delivering either a spray or a liquid in a uniform stream to the user.

15           Referring to the embodiment shown in Figures 2 - 5, cap member 10 and actuating member 11 are molded of a plastic material and adapted to be press-fitted into assembly. Cap member 10 includes a skirt 12 which is adapted to be secured to the neck of a bottle either by way  
20 of a snap fitting or, as illustrated in the drawings, a threaded fitment for the neck of a squeeze bottle. It will be appreciated that the threaded skirt 12 shown in the drawings, may include a safety seal which, when it is broken, indicates that the bottle has been tampered with.  
25 Moreover, a tamperproofing seal can be attached to the

bottle mouth. In addition, the actuating member 11 may include a similar structure for indicating to a user that the actuating member has been tampered with.

5 Cap member 10 includes skirt portion 12 and first, second and third coaxial cylindrical members 13, 14 and 15. First and second coaxial cylindrical members 13 and 14 are spaced a distance sufficient to define a cylindrical flow passage FP with center cylindrical member 13 being secured to the cap top CT by a plurality of wings 16. The interior  
10 surface of cylindrical member 14 is provided with a plurality of ribs 17, 18, 19 which constitute locating coacting detents.

A portion 20 of a spray device, such as swirl chamber or cover top SC, which will be described more fully  
15 hereafter is formed on the free end of cylindrical member 13 along with a seal surface SF. Swirl chamber portion 20 has at least one and preferably a pair of side apertures 20a for introducing fluid to the swirl chamber SC.

Actuating member 11 has a fluid exit aperture 22 and  
20 a manually graspable member 23. Internally, a cylindrical member 24 has an outwardly projecting detent/stop rib 25. On the upper interior portions of cylindrical member 24 is formed a second portion 27 of the swirl chamber SC and annular recess 28 for sealingly receiving the walls forming  
25 swirl chamber portion 20 and a seal surface 30, the recesses 28 and seal surface 30 sealing the flow passage

between members 13 and 14 to thereby block all flow of all fluid or liquid from the water bottle.

The actuating member is provided with three positions: (1) closed or fully down where the seal surfaces SF and 30 are sealingly engaged and where the flow stops or there is no flow through the nozzle, (2) in the middle position where swirl cavity SC portions 20 and 27 form the swirl cavity and there is flow through apertures or openings 20a to the swirl chamber or cavity portion 20, 27 to produce a conical fan as shown in Figure 4, and (3) and the all-open position where the swirl function is disabled and flow over the swirl nozzle (see the arrows in Figure 5) produces a stream for drinking.

Referring now to the spray position shown in Figure 4, assuming that it is a squeeze bottle that contains the liquid (water) being dispensed, when the bottle is squeezed, pressure is generated forcing liquid into the top. Liquid enters the swirl cavity SC, now formed by the juxtaposed upper swirl cavity portion 27 and the lower swirl cavity portion 20 on the upper end of cylindrical member 13, via side apertures 20a, and, as indicated, the liquid rises in the swirl cavity and exits through the outlet orifice 22 as a conical spray. The angle of momentum created by the swirling action causes a spray to disperse in a conical shape in the form of a conical spray which crosses itself to provide droplets of a given size and in a full coverage spray.



In the drink position shown in Figure 5, with the actuated member fully extended where the detent member 25 engages detent stop 19, when the bottle is squeezed generating force pressure and forcing fluid in the top, the swirl (spray) feature is disabled and fluid travels over and throughout the swirl cavity portion and fluid exits through the outlet orifice 22 in a continuous stream. Flow can also be generated by applying a vacuum (through sucking action) at the exit orifice with the above-described flow path or by a manually actuated pump.

In the embodiment of the invention illustrated in Figures 6A-6F, a modified form of the swirl chamber embodiment of Figures 2-5 is illustrated. In this embodiment, instead of a pull-type actuating member, a twist or screw-type engagement of the operating member 60 with cap member 61 is provided. In the closed condition shown in Figures 6A and 6B, the cap member 61 has a plurality of openings 63 which are sealed by the inner surface 64 operating member 60. A swirl chamber 65 coupled to a common outlet 66 is formed in operating member 60. Swirl chamber feed passages 68, 69 are formed in projection 61p on the end of cap member 61.

When the operating member 60 has been twisted or unscrewed partially as indicated in Figures 6C and 6D, the outlet apertures in cap member 61 are opened or exposed in communication with a passage 61p leading to the swirl chamber passages 68, 69. When pressure is applied to

liquid inside the water bottle (not shown in Figures 6A - 6F), the liquid passes through apertures or passages 64 and are guided to swirl chamber feed passages 69, 70 which causes the fluid to swirl in the swirl chamber and exit as a conical spray through the common outlet 60o.

As shown in Figures 6C and 6F, on further twisting of the operating member 60, the operating member 60 is spaced further from the cap 61 by action of the threads 63, 64 so that the swirl feed passages are now inoperative and fluid or liquid from the chamber under pressure flows over the projection and through the common outlet through the swirl chamber without any swirl action being imparted thereto.

In the embodiment shown in Figures 7A - 7E, instead of a swirl chamber for forming the spray, a plurality of fluted serrations 70 are formed in the projection 71 on the cap member 70 come into play. These fluted serrations 70s can be straight serrations so that the flow indicated by the arrows enters a plurality of parallel passages defined by the grooves or flutes in the serrations and the walls of the common outlet passage causing the flow to issue as a spray. It will be appreciated that the serrations can be in the form of spiral serrations so as to give a swirling motion to fluid exiting through the individual passages formed by the serrations.

Figures 7E and 7F illustrate the fully extended position of the operating member whereby the function of the serrations is disabled and the water or fluid flows

through an annular gap 60g formed between the end of projection 70p and the common outlet after 70o.

In the embodiment shown in Figures 8A - 8F, the liquid spray is formed when the operating member 80 is in the position shown in Figures 7C and 7D. In this embodiment, the projection 81p on cap member 81 is frustoconical or tapered so that when the operating member 80 is in the position illustrated in Figure 7C, fluid issuing through the annular gap between the projection 80p and the edge of opening 80o is sheared thereby causing a spray to issue through the nozzle's common outlet opening 80o. In the fully extended position of the operating member 80 shown Figure 8E, the annular gap between the projection 80p and the opening 80o is very large so that there is no shear action and the water flows in the drinking mode described earlier herein.

In the embodiment shown in Figures 9A - 9F, one or more fluidic oscillators are formed in the projection 91p formed in the cap 91. In this embodiment, the projection 91p is cylindrical and the one or more fluidic oscillators FO may be of any type such as is disclosed in U.S. Patents Nos. 4,508,267; 5,213,270; 4,463,904; RE 33,158; 4,151,944 and 4,184,636 or the full coverage spring device disclosed in U.S. Application Serial No. 08/768,935 filed December 18, 1996 by Raghu et al. In this illustrated embodiment, a power nozzle feed aperture 95 is formed transversely in projection 90p and feeds the power nozzle of the one or

more fluidic oscillators FO so as to cause a sweeping action of liquid flowing through the one or more fluidic oscillators FO and thereby the ensuing spray.

As shown in Figures 9E and 9F, when the operating member 90 has been fully extended, fluid flows around the projection 90p through the annular gap 90 AG to the common outlet aperture 90o bypassing and in effect disabling the one or more fluidic oscillator so that the large volume of water can flow without being converted to a spray.

In each of the embodiments shown in Figures 6A - 9F, the "closed" spray and "drink" positions are preferably located by detents.

Thus, the invention has "spray" and "drink" functions as well as a "closed" function. In contrast to commonly used nozzles on disposable water bottles, the invention is easy to use because to open, the user simply pulls on the top of the nozzle (which can have frangible securement means for indicating whether its been tampered with) until the end stops are reached. This opens internal flow channels and allows the water to pass without forming a spray. In the closed mode, these channels are obviously blocked and sealed to prevent leakage. The present invention has the additional feature of a spray mode where the liquid is made to spray from a nozzle at a lower flow rate than the drink function. This spray can be used for a variety of functions including cooling, drinking, cleaning, cooking. While the invention as shown on a

screw-on type fitment, it can obviously be a snap-on type fitment. In addition to the conventional tamper indicators (e.g. broken frangible connectors and locks), the drink container can have a seal on it which must be removed  
5 before the invention can be utilized.

While preferred embodiments of the invention has been illustrated and described, it will be appreciated that other embodiments, adaptations and modifications to the invention can be incorporated without departing from the  
10 scope of the invention.

**WHAT IS CLAIMED IS:**

1. A fitment for dispensing liquid from a container, comprising:

cap member means to mount said fitment on a container having one or more liquid openings thereon for passing liquid from said container,

an operating member mounted on said cap member having a central opening and at least three functional and positions relative to said cap member, including (a) a closed position, (b) spray position, and (c) a full flow drink position, said cap member and said operating member having abutting seal surfaces when said operating member is in said closed position,

said operating member having spray forming elements for issuing a spray through said central opening rendered operative when said operating member is in said spray position, relative to said cap member, and

said cap member and said operating member defining a substantially unimpeded flow passage to said central opening when said cap member and said operating member are in said full flow drink position.

2. The fitment described in Claim 1 wherein said cap member has a central projection which is coaxial with said central opening in said operating member.

3. The fitment defined in Claim 1 wherein said cap member has a central projection which is coaxial with said central opening, said cap member having an annular shoulder defining a annular liquid shear opening with said central projection on said cap member when in said spray position and a substantially larger annular opening in said full flow drink position.

4. The fitment defined in Claim 1 wherein said cap member has a fluted central projection having a plurality of flutes on the periphery thereof which is coaxial with said central opening, said operating member has an annular shoulder coaxial with said central opening such that when said operating member is in said spray position, liquid under pressure from said container flows through said plurality of flutes and form a spray in said central outlet.

5. The fitment defined in Claim 1 wherein said cap member has a central projection which is coaxial with said central opening, and a plurality of swirl chamber feed passages in said central projection, a swirl chamber formed at least in part in said operating member such that when said operating member is in said spray position said swirl chamber feed passages receive liquid and/or pressure from said container and feed the liquid to said swirl chamber and form a spray issuing from said central opening.

6. The fitment defined in Claim 5 wherein said swirl chamber is formed partly in said cap and partly in said operating member, respectively.

7. The fitment defined in Claim 1 wherein said cap member has a central projection, one or more fluidic oscillators formed in said central projection, said one or more fluidic oscillator having an outlet for issuing a jet  
5 of oscillating liquid spray through said central opening, when said operating member is in said spray position and said one or more fluidic oscillator being disabled when said operating member is in said full flow drink position.

8. The fitment defined in any one of Claim 1 including detent means between said cap and operating member define and locate said closed spray and full flow positions of said members.

9. The fitment defined in any one of Claim 1 wherein said means mounting said operating member on said cap member includes engaged threads on said members, respectively.

10. A liquid dispensing fitment for a liquid container having a mouth adapted to receive a fitment, comprising:



a skirt member adapted for securement to the mouth of  
5 said liquid container,

said skirt member having a first and second coaxial  
cylindrical members spaced to define a flow passage  
therebetween, the first of said cylindrical members having  
a wall and a spaced detent means on said wall,

10 an actuating member having a liquid exit opening and  
a depending detent member with coacting detent means on  
said detent member coacting with said spaced detent means  
to define closed, spray and drink positions for said  
actuating member,

15 a spray forming means for introducing liquid therein  
from said flow passage to cause a spray to issue to ambient  
through said liquid exit opening,

and means for disabling said spray forming means so as  
to allow a continuous liquid stream fluid to flow through  
20 said liquid exit opening.

11. A liquid dispensing fitment for a liquid  
container having a mouth adapted to receive a fitment,  
comprising:

a skirt member adapted for securement to the mouth of  
5 said liquid container,

said skirt member having a first and second coaxial  
cylindrical members spaced to define a flow passage  
therebetween, the first of said cylindrical members having

an interior wall and a spaced detent means on said interior  
10 wall,

an actuating member having a liquid exit opening and  
a depending detent member with coacting detent means on  
said detent member coating with said spaced detent means to  
define closed, spray and drink positions for said actuating  
15 member,

a swirl cavity with means for introducing liquid  
therein from said flow passage to cause a full coverage  
spray to issue to ambient through said liquid exit opening,  
and means for disabling said swirl cavity so as to  
20 allow a continuous liquid stream fluid to flow through said  
liquid exit opening.

**AMENDED CLAIMS**

[received by the International Bureau on 14 January 2000 (14.01.00);  
original claims 1-11 replaced by new claims 1-6 (3 pages)]

1. A fitment for dispensing liquid from a container,  
comprising:

a cap member for mounting said fitment on a container,  
said cap member having one or more liquid openings thereon  
5 for passing liquid from said container, a central  
projection formed on said cap member,

an operating member mounted on said cap member, said  
operating member having a central opening coaxial with said  
central projection and at least three functional positions  
10 relative to said cap member, including (a) a closed  
position, (b) spray position, and (c) a full flow drink  
position, said cap member and said operating member having  
abutting seal surfaces when said operating member is in  
said closed position,

15 said operating member and said projection having spray  
forming elements for forming and issuing a unitary full  
coverage spray through said central opening in said  
operating member, said spray forming elements being  
rendered operative when said operating member is in said  
20 spray position, relative to said cap member, and

said cap member and said operating member defining a  
substantially unimpeded flow passage to said central  
opening when said cap member and said operating member are  
in said full flow drink position.

2. The fitment defined in Claim 1 wherein said central projection has a plurality of swirl chamber feed passages, a swirl chamber formed at least in part in said operating member such that when said operating member is in said spray position said swirl chamber feed passages receive liquid and/or pressure from said container and feed the liquid to said swirl chamber and form a spray issuing from said central opening.

3. The fitment defined in Claim 2 wherein said swirl chamber is formed partly in said cap and partly in said operating member, respectively.

4. The fitment defined in Claim 1 wherein said cap member has an annular shoulder defining a annular liquid shear opening with said central projection on said cap member when in said spray position and a substantially larger annular opening in said full flow drink position.

5. The fitment defined in Claim 1 including one or more fluidic oscillators formed in said central projection, each said one or more fluidic oscillator having an outlet for issuing a jet of oscillating liquid spray through said central opening, when said operating member is in said spray position and said one or more fluidic oscillator being disabled when said operating member is in said full flow drink position.

6. A liquid dispensing fitment for a liquid container having a mouth adapted to receive a fitment, comprising:

5 a skirt member adapted for securement to the mouth of said liquid container,

said skirt member having a first and second coaxial cylindrical members spaced to define a flow passage therebetween, the first of said cylindrical members having an interior wall and a spaced detent means on said interior wall,

10 an operating member having a liquid exit opening and a depending detent member with coacting detent means on said detent member coacting with said spaced detent means to define closed, spray and drink positions for said actuating member,

15 a swirl chamber and a plurality of swirl chamber feed passages for introducing liquid therein from said flow passage into said swirl chamber to cause a unitary full coverage spray to issue to ambient through said liquid exit opening,

20 and means for disabling said swirl chamber so as to allow a continuous liquid stream fluid to flow through said liquid exit opening.

1/8

FIGURE 1A

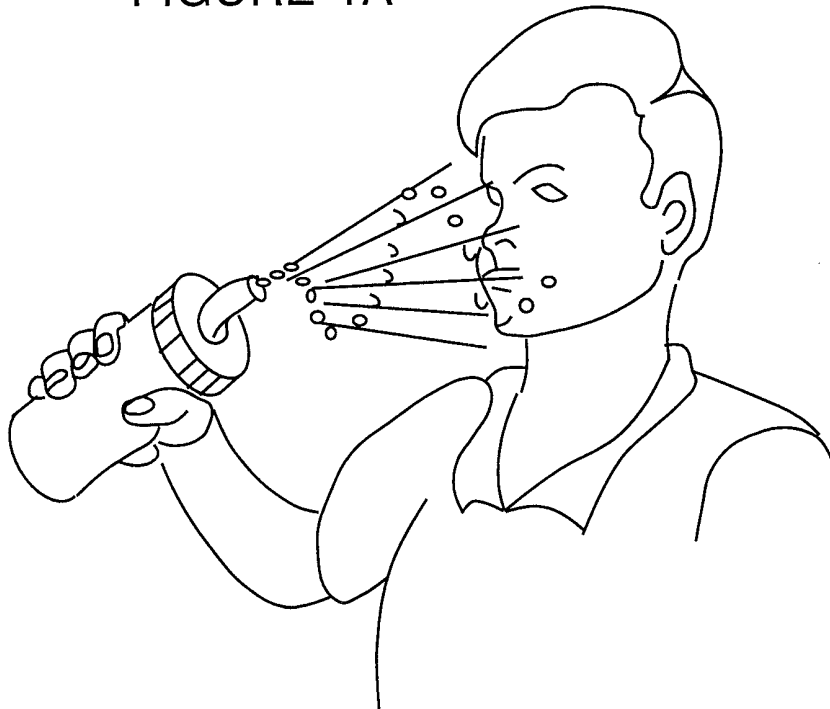
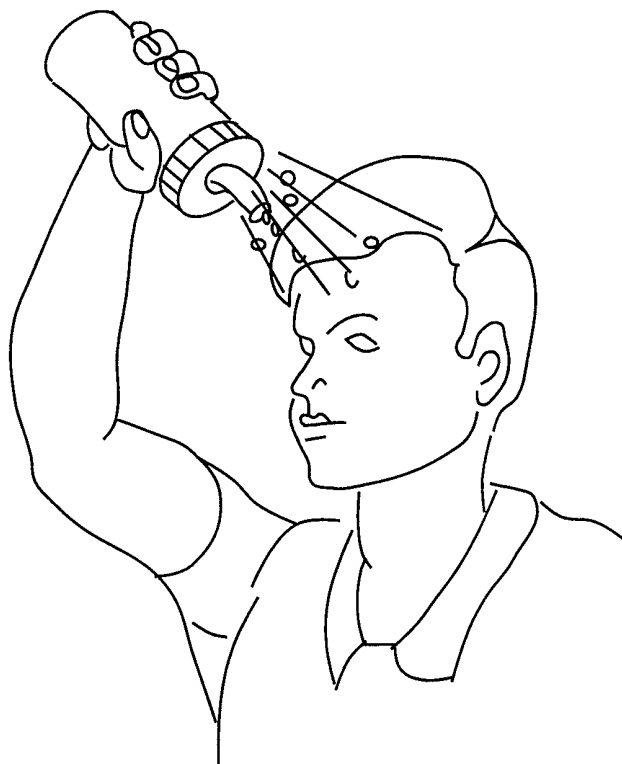

FIGURE 1B



2/8

FIGURE 1C



FIGURE 2

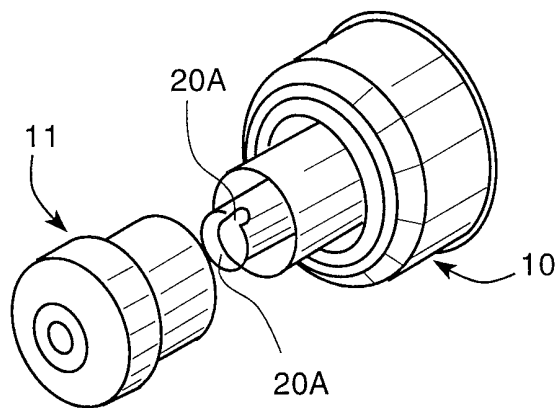

FIGURE 3

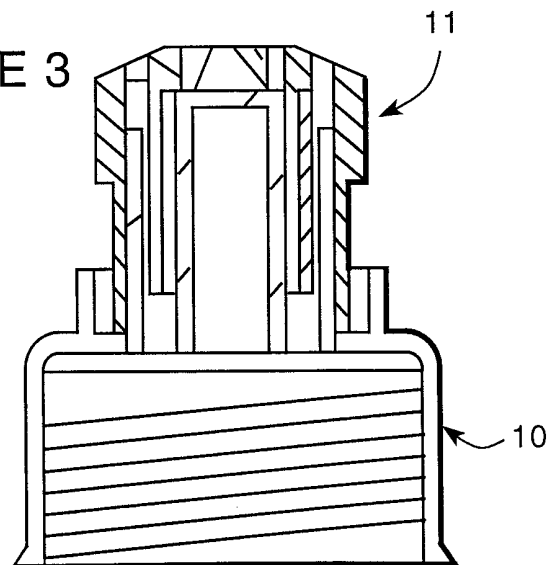

FIGURE 4

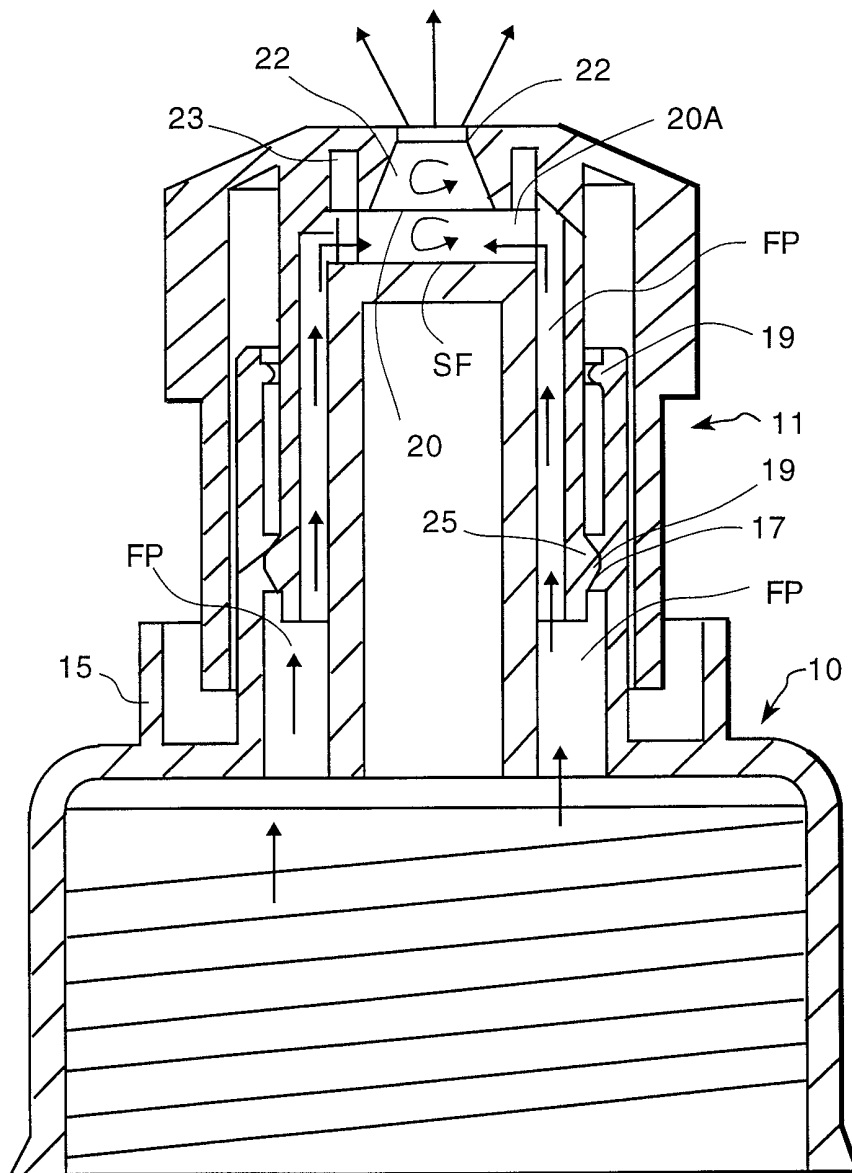



FIGURE 5

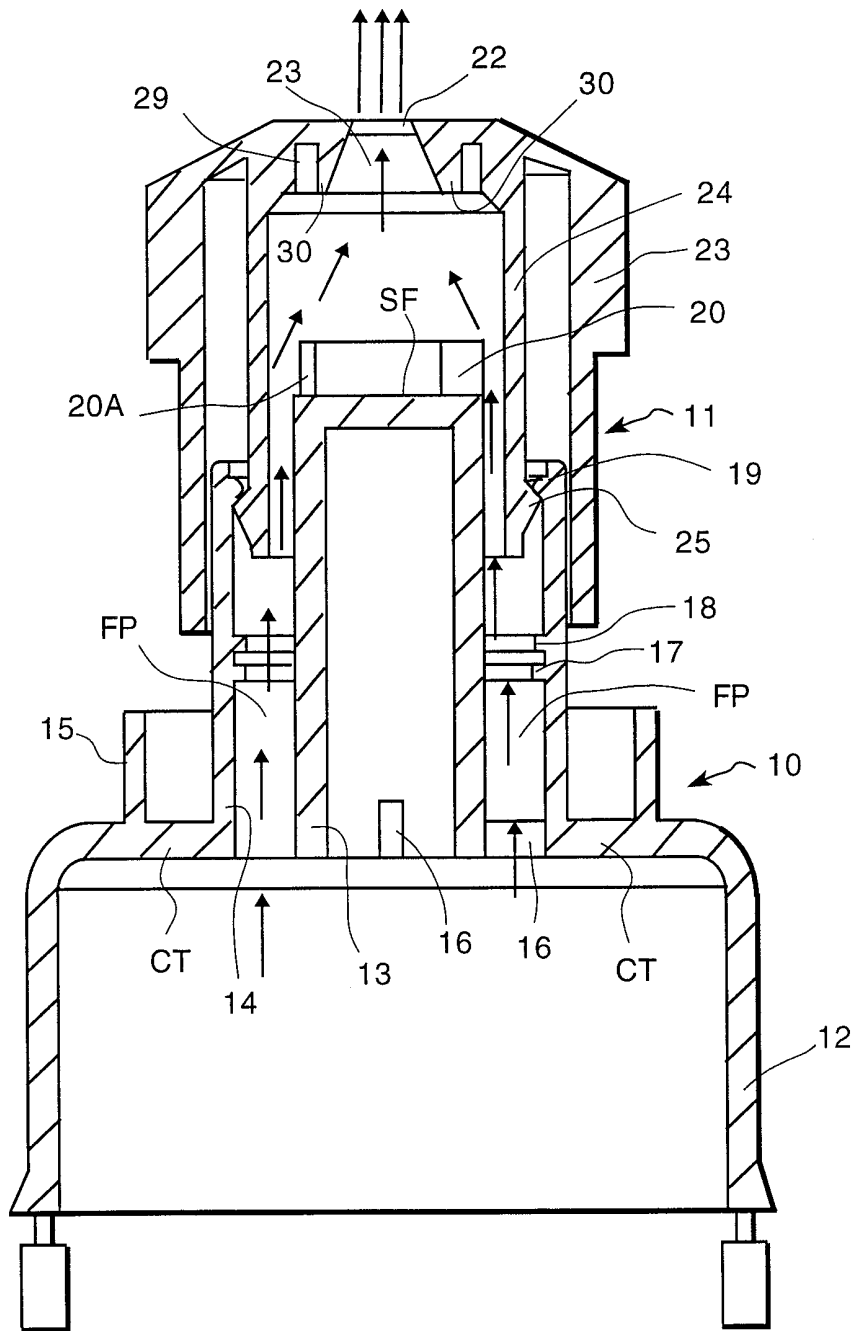

FIGURE 6A

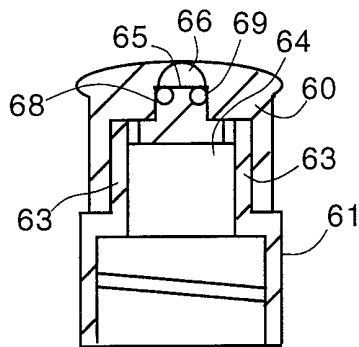

FIGURE 6B

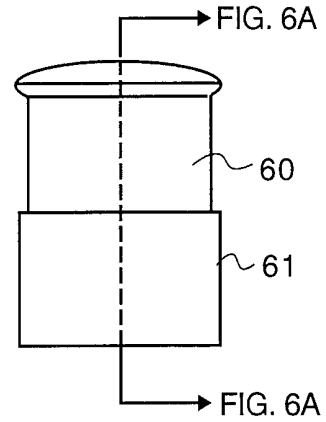

FIGURE 6C

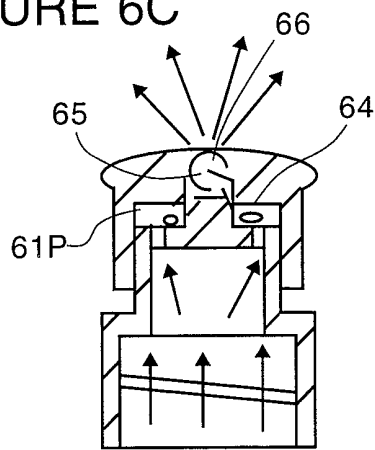

FIGURE 6D

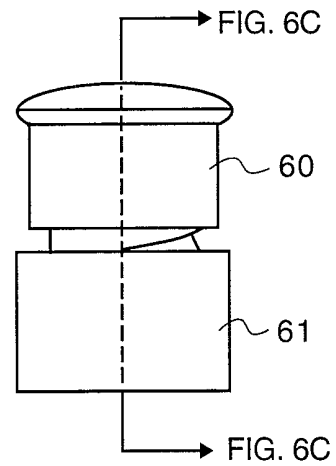

FIGURE 6E

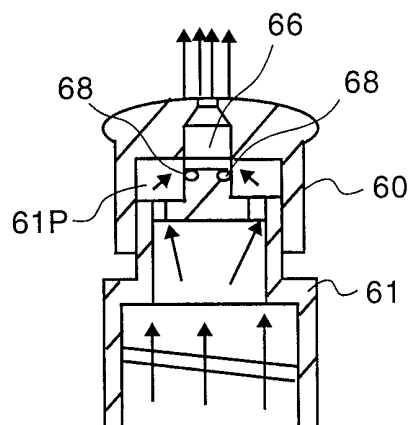

FIGURE 6F

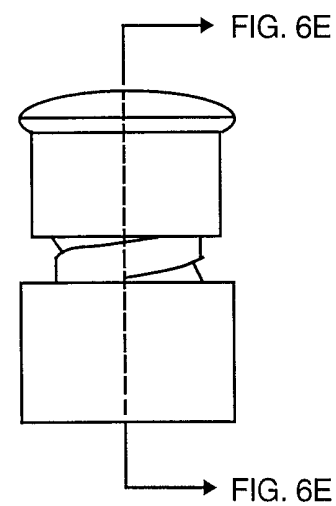

FIGURE 7A

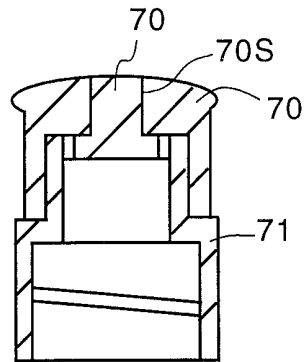

FIGURE 7B

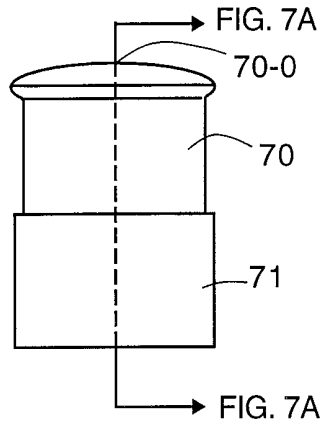

FIGURE 7C

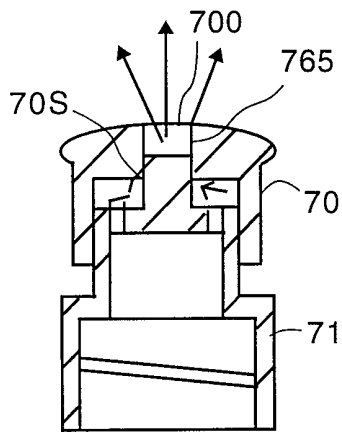

FIGURE 7D

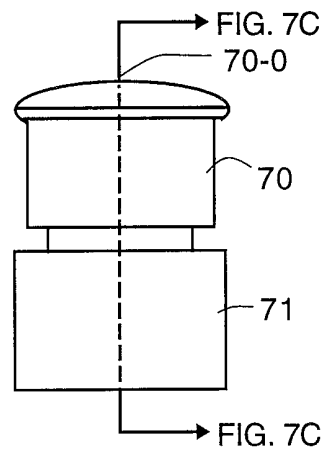

FIGURE 7E

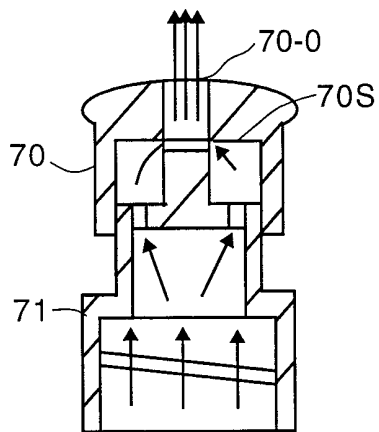

FIGURE 7F

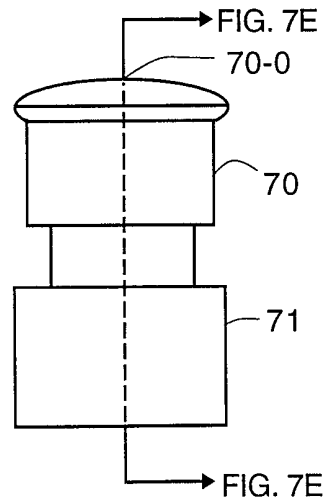

FIGURE 8A

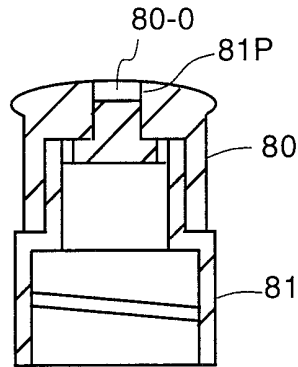

FIGURE 8B

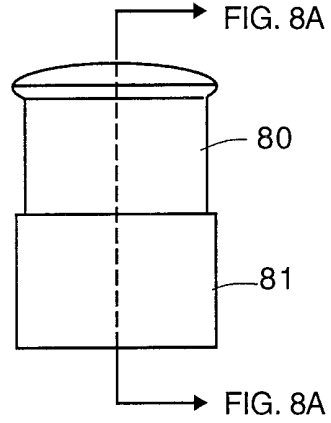

FIGURE 8C

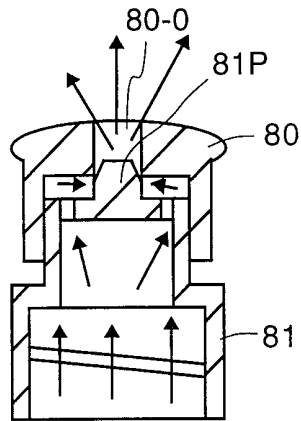

FIGURE 8D

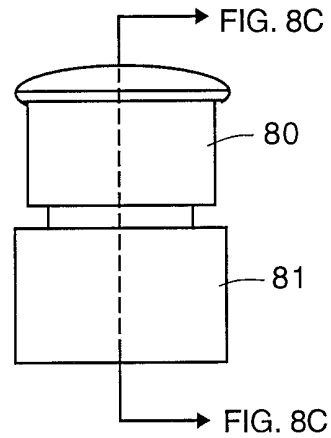

FIGURE 8E

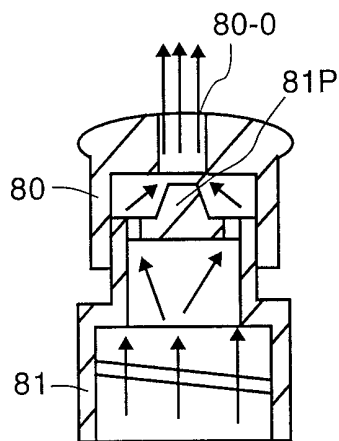

FIGURE 8F

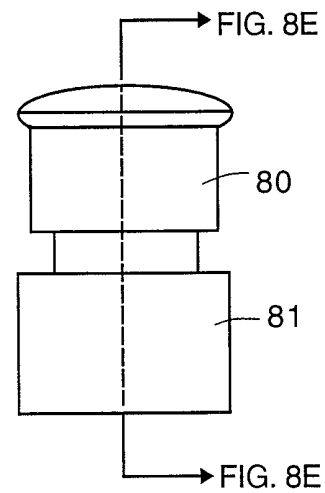

FIGURE 9A

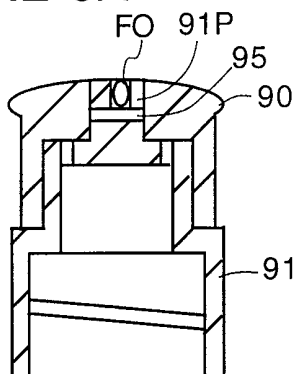

FIGURE 9B

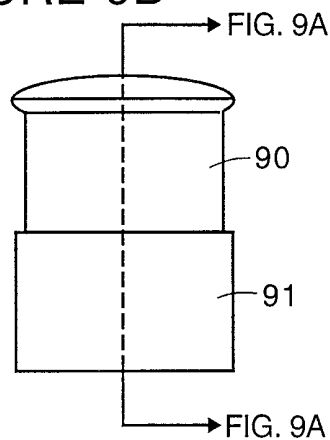

FIGURE 9C

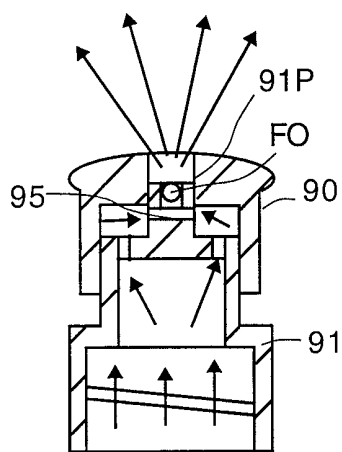

FIGURE 9D

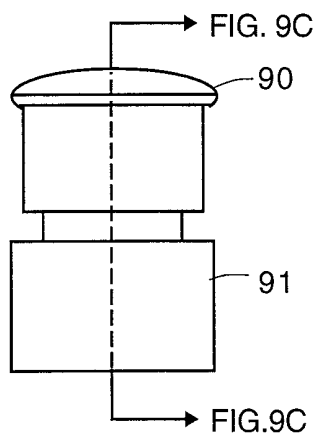

FIGURE 9E

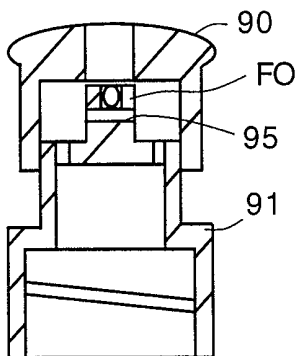
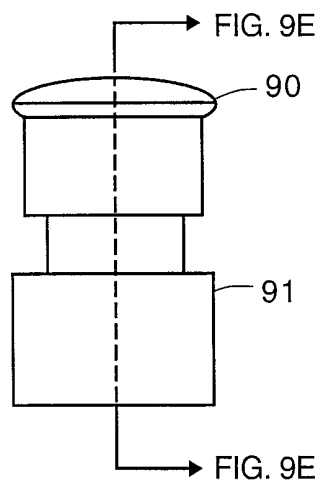

FIGURE 9F



## INTERNATIONAL SEARCH REPORT

International application No.  
PCT/US99/18816

## A. CLASSIFICATION OF SUBJECT MATTER

IPC(6) : A62C 31/02  
US CL : 239/390, 397

According to International Patent Classification (IPC) or to both national classification and IPC

## B. FIELDS SEARCHED

Minimum documentation searched (classification system followed by classification symbols)

U.S. : 239/390, 397

Documentation searched other than minimum documentation to the extent that such documents are included in the fields searched

Electronic data base consulted during the international search (name of data base and, where practicable, search terms used)

WEST 1.2

## C. DOCUMENTS CONSIDERED TO BE RELEVANT

Category*	Citation of document, with indication, where appropriate, of the relevant passages	Relevant to claim No.
X --- Y	US 4,667,881 A (MICHELLOTTI) 26 MAY 1987, See entire document.	1-6, 8, 10-11 ----- 7, 9
Y	US 5,213,270 A (STOUFFER ET AL) 25 MAY 1993, See entire document.	7
Y	US 2,785,926 A (LATASTE) 19 MARCH 1957, See entire document.	9
A	US 3,170,633 A (CASTELLI) 23 FEBRUARY 1965, See entire document.	1-11
A	US 3,967,765 A (MICALLEF) 06 JULY 1976, See entire document.	1-11

 Further documents are listed in the continuation of Box C.  See patent family annex.

* Special categories of cited documents:	*T* later document published after the international filing date or priority date and not in conflict with the application but cited to understand the principle or theory underlying the invention
*A* document defining the general state of the art which is not considered to be of particular relevance	*X* document of particular relevance; the claimed invention cannot be considered novel or cannot be considered to involve an inventive step when the document is taken alone
*E* earlier document published on or after the international filing date	*Y* document of particular relevance; the claimed invention cannot be considered to involve an inventive step when the document is combined with one or more other such documents, such combination being obvious to a person skilled in the art
*L* document which may throw doubts on priority claim(s) or which is cited to establish the publication date of another citation or other special reason (as specified)	*&* document member of the same patent family
*O* document referring to an oral disclosure, use, exhibition or other means	
*P* document published prior to the international filing date but later than the priority date claimed	

Date of the actual completion of the international search  
26 OCTOBER 1999

Date of mailing of the international search report

18 NOV 1999

Name and mailing address of the ISA/US  
Commissioner of Patents and Trademarks  
Box PCT  
Washington, D.C. 20231

Facsimile No. (703) 305-3230

Authorized officer

ANDRES KASHNIKOW *Diane Smith*  
Telephone No. (703) 308-1137

## INTERNATIONAL SEARCH REPORT

International application No.  
PCT/US99/18816

C (Continuation). DOCUMENTS CONSIDERED TO BE RELEVANT

Category*	Citation of document, with indication, where appropriate, of the relevant passages	Relevant to claim No.
A	US 5,664,732 A (SMOLEN, Jr. et al) 09 SEPTEMBER 1997, See entire document.	1-11
A	US 5,526,985 A (MARTIN) 18 JUNE 1996, See entire document.	1-11