

**(12) STANDARD PATENT**  
**(19) AUSTRALIAN PATENT OFFICE**

(11) Application No. **AU 2007215263 B2**

(54) Title  
**Device and method for single-needle in vivo electroporation**

(51) International Patent Classification(s)  
**A61N 1/32** (2006.01)

(21) Application No: **2007215263** (22) Date of Filing: **2007.02.09**

(87) WIPO No: **WO07/095140**

(30) Priority Data

(31) Number	(32) Date	(33) Country
<b>60/772,255</b>	<b>2006.02.11</b>	<b>US</b>

(43) Publication Date: **2007.08.23**

(44) Accepted Journal Date: **2011.07.07**

(71) Applicant(s)  
**Genetronics, Inc.**

(72) Inventor(s)  
**McHugh, George;Tjelle, Torunn Elisabeth;Mathiesen, Iacob;Kjeken, Rune**

(74) Agent / Attorney  
**FB Rice, Level 23 44 Market Street, Sydney, NSW, 2000**

(56) Related Art  
**US 5702359**  
**US 2002/0198512**

(19) World Intellectual Property Organization  
International Bureau



(43) International Publication Date  
23 August 2007 (23.08.2007)

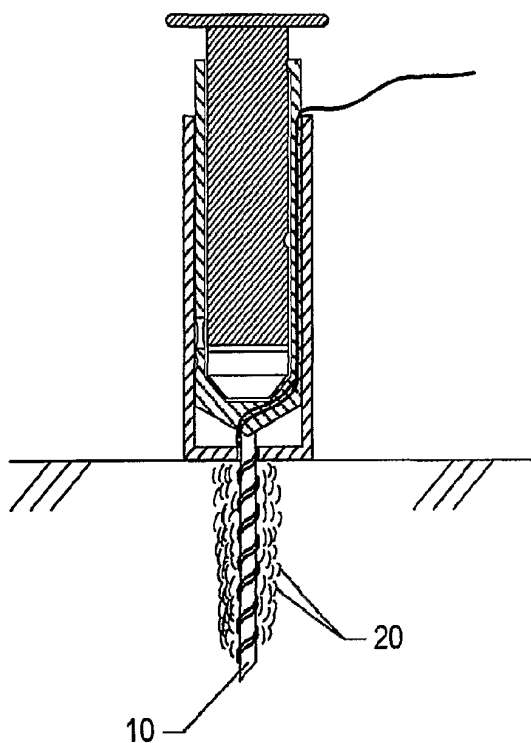
PCT

(10) International Publication Number  
WO 2007/095140 A3

- (51) International Patent Classification:  
A61N 1/32 (2006.01)
- (21) International Application Number:  
PCT/US2007/003615
- (22) International Filing Date: 9 February 2007 (09.02.2007)
- (25) Filing Language: English
- (26) Publication Language: English
- (30) Priority Data:  
60/772,255 11 February 2006 (11.02.2006) US
- (71) Applicant (for all designated States except US): GEN-ETRONICS, INC. [US/US]; 11494 Sorrento Valley Road, San Diego, CA 92121-1318 (US).
- (72) Inventors; and
- (75) Inventors/Applicants (for US only): KJEKEN, Rune [NO/NO]; 11494 Sorrento Valley Road, San Diego, CA 92121-1318 (US). MATHIESEN, Iacob [NO/NO]; 11494 Sorrento Valley Road, San Diego, CA 92121-1318 (US). TJELLE, Torunn, Elisabeth [NO/NO]; 11494 Sorrento Valley Road, San Diego, CA 92121-1318 (US). MCHUGH, George [US/US]; 11494 Sorrento Valley Road, San Diego, CA 92121-1318 (US).
- (74) Agents: MURDOCK, Douglas, C. et al.; BioTechnology Law Group, 527 N. Highway 101, Suite E, Solana Beach, CA 92075-1173 (US).
- (81) Designated States (unless otherwise indicated, for every kind of national protection available): AE, AG, AL, AM, AT, AU, AZ, BA, BB, BG, BR, BW, BY, BZ, CA, CH, CN, CO, CR, CU, CZ, DE, DK, DM, DZ, EC, EE, EG, ES, FI, GB, GD, GE, GH, GM, GT, HN, HR, HU, ID, IL, IN, IS, JP, KE, KG, KM, KN, KP, KR, KZ, LA, LC, LK, LR, LS, LT, LU, LV, LY, MA, MD, MG, MK, MN, MW, MX, MY, MZ, NA, NG, NI, NO, NZ, OM, PG, PH, PL, PT, RO, RS, RU, SC, SD, SE, SG, SK, SL, SM, SV, SY, TJ, TM, TN, TR, TT, TZ, UA, UG, US, UZ, VC, VN, ZA, ZM, ZW.
- (84) Designated States (unless otherwise indicated, for every kind of regional protection available): ARIPO (BW, GH, GM, KE, LS, MW, MZ, NA, SD, SL, SZ, TZ, UG, ZM, ZW), Eurasian (AM, AZ, BY, KG, KZ, MD, RU, TJ, TM), European (AT, BE, BG, CH, CY, CZ, DE, DK, EE, ES, FI, FR, GB, GR, HU, IE, IS, IT, LT, LU, LV, MC, NL, PL, PT, RO, SE, SI, SK, TR), OAPI (BF, BJ, CF, CG, CI, CM, GA, GN, GQ, GW, ML, MR, NE, SN, TD, TG).
- Published:  
— with international search report

[Continued on next page]

(54) Title: DEVICE AND METHOD FOR SINGLE-NEEDLE *IN VIVO* ELECTROPORATION



(57) Abstract: Described is a device and method for administration of molecules to tissue *in vivo* for various medical applications, the device comprising a single hypodermic injection needle and at least two spaced elongate electrodes which provide for the ability, when the needle is inserted into tissue, such as skin or muscle, to pulse tissue with a non-uniform electric field sufficient to cause reversible poration of cells lying along or in close proximity to the track made by the needle upon its insertion into said tissue.

WO 2007/095140 A3



— *before the expiration of the time limit for amending the claims and to be republished in the event of receipt of amendments*

*For two-letter codes and other abbreviations, refer to the "Guidance Notes on Codes and Abbreviations" appearing at the beginning of each regular issue of the PCT Gazette.*

**(88) Date of publication of the international search report:**

10 January 2008

## **DEVICE AND METHOD FOR SINGLE-NEEDLE *IN VIVO* ELECTROPORATION**

### **FIELD OF THE INVENTION**

[001] This invention relates to electroporation of cells *in vivo*, particularly cells of a patient's tissues. More specifically, this invention relates to novel devices and methods for delivering molecules to cells situated at, near and/or adjacent to a predetermined insertion track site of an elongate single-needle electrode. Still more specifically, the invention concerns the electroporated delivery of substances into cells along and in the vicinity of the needle track made by insertion of the electrode from the surface of a tissue and into the tissue to a depth of from 3 millimeters to 3 cm, which tissues can comprise any tissues, including without limitation skin, striated and smooth muscle, mucosa, and organs.

### **BACKGROUND OF THE INVENTION**

[002] The following description includes information that may be useful in understanding the present invention. It is not an admission that any such information is prior art, or relevant, to the presently claimed inventions, or that any publication specifically or implicitly referenced is prior art.

[003] Electroporation has been applied to delivering molecules to subsurface tissues using various multiple-electrode designs such as arrays of two or more electrodes that typically are designed as needle electrodes for insertion into said tissue. Generally, such arrays define a treatment zone lying between the needle electrodes of the array. Such treatment zones therefore comprise a three dimensional volume of tissue wherein cells within the treatment zone are exposed to an electric field of an intensity sufficient to cause temporary or reversible poration, or even sometimes irreversible poration, of the cell membranes to those cells lying within and or near the three dimensional volume.

[004] Current practices for electroporating cells in tissue include use of significant voltages in order to impart through the three dimensional treatment zone a relatively uniform electric field. By "relatively uniform" is meant that electric lines of force coincident with application of an electric pulse sufficient to cause poration is imparted across the cells somewhat evenly throughout the three dimensional treatment zone volume. Ultimately, a large number of electrode needles combined with large injection volumes and high electrical fields have been necessary to ensure a sufficient overlap between an injected drug and the tissue volume experiencing the electrical field since typically, the injection bolus that is delivered to the tissues quickly spreads from the

injection site. Use of high electric fields and large electrode arrays has several drawbacks. For example, use of many needles and high electric field (voltages) causes more pain while high injection volume makes dosing difficult to control as it causes waste of the drug (most of the drug is not getting into the cells as it will be outside the treatment zone). Also, use of such multiple needle devices is cumbersome and a cause for apprehension from the standpoint of the patient.

**[005]** Besides the invasive aspect of a device with multiple needles, typical electroporation techniques, as stated above, result in variability in electroporation of cells within a treatment zone. This is a drawback to medical use of electroporation in that dispersion of treatment molecules of the injected bolus into surrounding tissue results in loss of control as to the amount of such treatment molecule that is ultimately transfected into cells within the treatment zone by the electroporation event. Thus, a need exists in the electroporation arts for a device and method to narrow or refine control over "dosing" of treatment molecules into specific and well defined delivery sites within a patient's tissue. Likewise, there is still a need in the art for methodologies and devices that can electroporate with less invasiveness and impart less pain from the electric field pulse employed in the delivery of therapeutic substances to various tissues including skin, muscle, mucosa and organs.

**[005A]** Any discussion of documents, acts, materials, devices, articles or the like which has been included in the present specification is not to be taken as an admission that any or all of these matters form part of the prior art base or were common general knowledge in the field relevant to the present invention as it existed before the priority date of each claim of this application.

**[005B]** Throughout this specification the word "comprise", or variations such as "comprises" or "comprising", will be understood to imply the inclusion of a stated element, integer or step, or group of elements, integers or steps, but not the exclusion of any other element, integer or step, or group of elements, integers or steps.

### SUMMARY OF THE INVENTION

[005C] According to one aspect of the invention, there is provided a device for electroporation of tissue in vivo for delivering therapeutic substances into cells of said tissue comprising:

a. at least one single electroporating needle capable of penetrating said tissue, said needle comprising:

an elongated hollow shaft adapted for delivery of a fluid comprising a therapeutic substance to said tissue, said shaft having a length running from one end of the needle to a tip of the needle at the other end of the needle, and

at least two electrodes exposed along an outer surface of said shaft that are adapted to deliver a generally cylindrical electric field, said exposure selected from electrodes spaced and electrically isolated from one another and situated linear and parallel to one another and parallel to the length of said shaft, or spiraling and parallel to one another along the length of said shaft; and

b. electric conduits capable of connecting each of said electrodes to an electrical energy source, wherein when said shaft is inserted into said tissue and said electrodes are energized by said energy source, said electrodes are capable of generating an electric field in a treatment zone surrounding said shaft sufficient to cause cells in said treatment zone to become reversibly porated so as to allow said cells to take up said therapeutic substance.

[005D] According to another aspect of the invention, there is provided a method of electroporating cells of tissue in vivo with a therapeutically useful composition comprising:

a. providing at least one single electroporating needle capable of penetrating said tissue, said needle comprising:

an elongated hollow shaft adapted for delivery of a fluid comprising a therapeutic substance to said tissue, said shaft having a length running from one end of the needle to a tip of the needle at the other end of the needle, and

at least two electrodes exposed along an outer surface of said shaft that are adapted to deliver a generally cylindrical electric field, said exposure selected from electrodes spaced and electrically isolated from one another and situated linear and parallel to one another and parallel to the length of said shaft, or spiraling and parallel to one another along the length of said shaft; and

providing electric conduits capable of connecting each of said electrodes to an electrical energy source;

b. providing a reservoir containing said composition, said reservoir and composition being in fluid communication with a lumen running through said shaft;

c. forming a channel in a preselected treatment site on a patient by inserting said shaft into said tissue *in vivo* in said patient;

d. injecting said composition from said reservoir through said lumen into said treatment site comprising said channel;

e. providing a source of electrical energy to each of said electrodes sufficient to cause reversible poration of cells in said treatment site; and

f. activating said source of electrical energy to provide an electric pulse thereby electroporating said cells for their uptake of said composition.

[006] In a first embodiment, this invention provides for electroporation of cells *in situ*, particularly cells that are located subcutaneously, intradermally, subdermally, and/or intramuscularly (particularly skeletal muscle, striated, and smooth muscle, e.g., heart, muscle). In a related embodiment, the invention provides for the electroporation of cells near and/or adjacent to the track made by insertion of the single elongate needle electrode into tissue. For example, cells that become electroporated using the invention device are those situated within a radius from the needle track anywhere from between 0.0 and 5mm so as to comprise a generally cylindrical treatment zone imparted by the novel design and pulsing of and of the electric field imparted into the tissue by the single-needle electrode.

[007] In a second embodiment, the invention provides for any number of structural arrangements providing for at least two opposite electrode leads (i.e., at least one anode and at least one cathode) situated in association with a single elongate electrically inert shaft, which shaft itself can comprise electrodes and an electrically inert material, such as a medically acceptable plastic or polycarbonate, filling the space between the electrodes a 0.05 mm to a 1.5 mm between, or can comprise just elongate opposing spaced electrodes.

In either embodiment, the electrodes of the tissue penetrating single needle electrode or electrode containing shaft have spaced dimensions of between 0.05 mm and 1.5 mm. In a related embodiment, the electrodes themselves can have a length exposed along the elongate shaft anywhere from the whole needle length to just a section of the needle, such as near the shaft penetration tip. Further, the electrodes can have cross sectional dimensions of between 0.005 and 0.80 mm. In yet another structural arrangement embodiment, the single needle electrode can comprise a hypodermic needle comprising at least two elongate electrodes spaced along at least a portion of the length of the hypodermic needle exterior. For example, the hypodermic needle can include at least two electrodes (i.e., an anode and a cathode) running along a portion of the length of the needle. (See **Figure 1A**) In working embodiments, each electrode is connected to a source of electric energy for generating an electric field between opposite poles, i.e., one electrode is an anode and the other a cathode electrode. In other examples, multiple electrodes can be formed on the exterior of a hypodermic injection needle such as disclosed in **Figure 3** comprising multiple straight and parallel electrodes, or as depicted in **Figures 2 and 4** comprising multiple electrodes spiraled around the injection needle. In still further embodiments, the single-needle electrodes can be manufactured using any number of well understood methods including etching and layering per Micro electro-mechanical systems (MEMS) technologies. In such manufacturing methods, micromachining processes are used to add or strip away layers of substances important to the proper annealing, insulation, and conduct of electric pulses and circuitry. **Figures 13A, B, C, D and E** are photographs of the embodiment wherein the electrodes are etched on to the delivery needle shaft. Specifically, gold electrode layering has been coated above a layer of and inert substance (parlyene) which itself had been layered over the hypodermic needle shaft. Additional methods for manufacturing the elongate electrodes include extrusion technologies wherein the electrode leads are formed into and or along the shaft of an electrically inert composition having insulating qualities, such a plastic, a polyester derivative, or polyvinylchloride (PVC), or insulative carbon fiber. As shown in **Figure 14 A and B**, an elongate hollow needle can be extruded with electrode component, such as for example, wire either along opposite sides of the hollow shaft or in a spiral fashion as shown in **Figure 14 B**. Further still, the needle shaft can also comprise sections with no exposed electrodes. For example, one end of the needle shaft connects to a hub forming a connector for connecting to a source of fluid, such as for example, a syringe. Insulation near or along such section of the shaft may provide for additional lessening of electric



stimulus sensation noticeable by the patient. In yet a further embodiment with respect to any such electrode configuration described herein, each of the electrodes are individually energizable so that any combination of the electrodes may be energized in pairs (i.e., a cathode and anode) simultaneously together, or in any given sequence, and further using any type of pulse including without limitation monopolar, bipolar, exponential decaying, or pulse train combinations of any of the former.

**[008]** In a third embodiment, the invention provides for use of relatively low voltage and/or low current, which in turn not only provides sufficient electrical energy for causing reversible poration of cells in the treatment zone, but also allows for a low pain level experienced by subjects during application of electric pulses into the surrounding tissue, said application using nominal electric field strengths of generally between 1 and 100 V, typically between 2 and 50V, and more preferably between 3 and 25V. In a related aspect, electric current employed in the invention device and methods uses generally between 1-400 mAmps, typically between 5-200 mAmps, and more preferably between 20 and 100 mAmps. In a related embodiment, the amperage chosen depends on the total surface area of the electrodes. For example, the device may employ a range between 10 to 40, or 25 to 100, or 50 to 150, or 125 to 200, or 175 to 250, or 225 to 300, or 250 to 300 or 300 to 400 mAmps depending upon the total electrode surface area of each electrode. The smaller the surface area, the lower the amperage necessary to achieve an electroporating electric field in the *in situ* tissue. Pulses can be applied for between 1 and 1000 millisecond.

**[009]** In another embodiment, the invention provides for delivery of treatment molecules at various concentrations (e.g., for example, between 0.05 $\mu$ g-3 mg/ml) and preferably at low bolus volumes (e.g., for example, generally 1 $\mu$ l to 1ml). In a related embodiment, using a structural embodiment inclusive of a delivery tube associated with the single needle electrode shaft, the volume of treatment molecules immediately following injection into the tissue (such as a controlled injection wherein the injectate is delivered during insertion of the needle) surprisingly remains to a substantial level in the vicinity of the injection needle track. Treatment molecules are contemplated to include therapeutic drugs, e.g., small molecules, organic compounds, as well as proteins, and nucleic acids encoding polypeptides having either a biologic activity or that will induce an immune response in the host once such polypeptide is expressed in the electroporated cell. The polypeptides once expressed in the cell are available for interacting with cellular metabolic machinery and immune system pathways.

[010] In yet another embodiment, electrical energy used to pulse the tissue provides for a unique electric field that is unlike prior applied fields used for electroporation of similar tissues. Specifically, prior art electric fields intentionally and inherently impart what has been recognized in the electroporative arts as a “uniform” electric field meaning that the applied electrical energy is of sufficient strength to impart a nominal field strength and a relatively even voltage drop across the treatment zone created by widely separating the electrodes a given distance apart from one another and placing the target treatment zone optimally central between said spaced electrodes. Such electrode array designs when pulsed in tissue tend to electroporate cells primarily within the zone bordered by the electrodes generally in the vicinity of the electric lines of force and to a smaller degree a zone of cells situated just adjacent and surrounding the three dimensional treatment zone.

[011] In contrast, the current invention uses electric fields that comprise a generally cylindrical or columnar “non-uniform” field that is created about the length of the needle shaft thereby creating a treatment zone of cells lying within an area close enough to the centrally placed electrodes to be subjected to an electroporation field “outside” the immediate location of the electrodes, of sufficient strength to porate said cells. Such a treatment zone is completely external to and surrounding the central needle and electrodes and the non-uniform field dissipates relative to the distance outward from the electrode/needle. Generally, it is thought that the dissipation in electrical energy as the distance from the single needle electrode increases is parallel to the dissipation found in other physical phenomenon wherein energy, here energy sufficient to reversibly porate cells, dissipates at an exponential rate. However, such dissipation rate if applicable does not negatively affect the functioning of the invention device or the intended outcome of delivering substances into cells in a defined zone. Thus, since electrical energy necessary to cause cell poration dissipates with the distance from the electrical field source, the area around the needle tract that is susceptible to electroporation is inherently confined to a central core correlating to the length of the needle track and laterally to a given radius forming therefore a generally cylindrical treatment zone of variable radii depending upon the pulse energy imparted to the electrodes. In a further related embodiment, the more energy used to pulse, the greater the potential to damage cells directly in contact with the electrodes. It is yet a further intention of the invention methods to employ the ability to cause such damage for the purpose of further stimulating the immune system. Thus, treatment regimens can be used that intentionally impart a greater rather than a lesser energy so as to provide a stimulus for immune response activity around the treatment site.

[012] In other embodiments, the device can be used to deliver drugs, natural polypeptides having a biologic activity, and genes encoding such polypeptides that can be expressed *in situ* in cells within the treatment zone for treating disorders or for modulating an immune response in the host and/or for treating a variety of diseases including but not limited to diseases caused by pathogenic organisms and viruses and cancers.

[013] Other features and advantages of the invention will be apparent from the following drawings, detailed description, and appended claims.

### BRIEF DESCRIPTION OF THE DRAWINGS

[014] Figure 1A is a drawing depicting a hypodermic needle with elongate electrodes integrated therein. The needle features a port for dispensing a liquid formulation from a lumen running there through, and a port for connecting to a fluid carrying reservoir.

[015] Figure 2 depicts an alternate embodiment of the invention device wherein the anode and cathode electrodes are parallel to one another through a plane formed in a spiral around the needle.

[016] Figure 3A is another alternate embodiment wherein a delivery needle comprises a multiplicity of anode and cathode electrodes running straight and parallel along the length of the delivery needle. As also depicted, this figure includes an example of a connector for connecting the electrodes to a source of electrical energy. Figure 3B depicts a view of the cross section of one example of an invention electrode along line A-A. As shown, in one configuration, the electrodes can be layered by any number of techniques known to those of skill in the fabrication arts on the outer sections of a delivery tube and lumen. In the drawing is depicted an inner needle 53 with lumen 54 surrounded by an insulating material 55 on which is layered the electrodes.

[017] Figure 4 is another example of an embodiment comprising electrodes spiraled around the delivery needle. The electrodes so spiraled can comprise a multiplicity of anode and cathode pairs, but typically comprise one or two pairs of electrodes, each pair comprising an anode and a cathode.

[018] Figures 5A-C depict one embodiment of the invention wherein the invention electrode is shown comprising further embodiments including a reservoir, typically a syringe styled reservoir, and a sharps cover which is capable of retracting as the needle is inserted into a patient tissue. The drawing also shows other features that can be embodied within the invention device such as a resilient membrane which can be pierced such as by a needle to fill the reservoir and mechanisms for allowing the sharps cover and the syringe plunger to be held in place either in an extended or retracted position. Moreover, the

retractable sharps cover also act as a needle guide and can be fitted with stops to act as a depth guide. Although not shown, the single needle electrode can be fitted to a syringe and attached to an automatic needle delivery/simultaneous fluid delivery electroporation device such as that depicted in US Patent Application 10/612,304 and PCT/GB2003/002887. In such embodiment, the device would only have one needle and one syringe.

[019] Figure 6 shows a depiction of the invention device in use wherein during insertion or after the electrode/delivery needle is inserted into the tissue, the fluid material administered, the electrodes are energized so as to impart an electric field outward from the needle track and into the tissue. The electric field dissipates outward into the tissue from the site of the inserted needle.

[020] Figure 7 shows a top view of a hypothetical tissue and a depiction of typical electric field that the invention device would generate in the tissue surrounding the needle track and having lateral dimensions (a) and (b).

[021] Figures 8A-C are drawings showing prior art arrays with typically relatively uniform lines of force and corresponding electric fields between array needles as opposed to that of the invention wherein a non-uniform lines of force and respective electric field surrounds the array and dissipates rapidly therefrom. For example, Figure 8A shows three opposing electrodes in a linear array wherein the lines of force between the electrodes are relatively uniform. In Figures 8B and C is depicted circular arrays wherein the treatment zone is central to the electrodes and under relatively uniform lines of force and respective electric fields (individually pulsed in opposing pairs, Figure 8B, or pulsed in pairs of opposing electrodes in different orientations, Figure 8C.).

[022] Figures 9A-D show yet a further embodiment of the invention device which comprises a guide for resting the needle and reservoir for penetration of tissue to be treated at an acute angle for use in methods that include delivery of treatment substances near the tissue surface. This angle is typically between 3 and 25 degrees from the plane formed by the general area of the tissue surface.

[023] Figure 10 shows partial view of delivery needles comprising electrodes exposed near the tip of the delivery needle. Figure 10A depicts a needle supporting straight electrodes while Figure 10B depicts a needle supporting spiral electrodes. The leads for each of the positive and negative anodes are depicted running up an internal section of the needle. Also, this depiction is intended to represent that the upper portion of the elongate

needles can comprise insulation either around the electrode leads and/or coating the upper needle shaft.

[024] Figures 11A and B show results of electroporation in a tissue wherein cells primarily near the needle track have been affected by poration. In Figure 11A is a series of photos showing adjacent slices of tissue while Figure 11B shows a close-up of a central slice directly along the needle track.

[025] Figure 12 shows the results of a single injection into rabbit high muscle of a nucleic acid containing an expression vector encoding a fluorescent marker protein (GFP) using an electroporation device according to the invention.

[026] Figures 13A, B, C, D, and E show magnified photographs of a prototype hypodermic needle wherein gold elongate electrodes have been etched onto a standard injection needle using MEMS technology, i.e., micro layering, and etching and relayering of materials onto the base injection needle shaft such that the electrodes comprise 1/4 of the needle shaft circumference each. Figure 13 A shows one view of the needle showing one long electrode running the length of the needle. In Figure 13 B, a detail photo is shown from an angle allowing visualization of the terminal sections of both gold electrodes. Figure 13 C is another perspective showing detail of the terminal sections of the electrodes etched onto the needle shaft. Figures 13D and E show another embodiment wherein the MEMs crafted electrodes are 1/16 the circumference of the needle shaft.

[027] Figures 14 A, B, and C are drawings showing additional embodiments of single-needle design where in the shaft comprises electrically inert material such as for example, plastic extruded with electrode leads built into the extruded hypodermic shaft. Figure 14A depicts straight electrodes running parallel to the needle shaft. Figure 14B depicts electrodes in a spiral about the shaft. Figure 14C depicts the cross section AA—AA of Figure 14A showing one embodiment wherein the electrode of the shaft can be connected to electrode leads positioned on the needle hub.

[028] Figure 15 is a graph showing the level of rabbit anti-human IgG antibodies produced following electroporation pulse using the single needle invention (■) versus no electroporation (▲)

[029] Figure 16 is a graph showing the level of rabbit anti-SEAP antibodies produced following electroporation pulse using the single needle invention (■) versus no electroporation (▲)

[030] Figures 17 A and B are photographs showing results of green florescent protein (GFP) expression following injection of plasmid DNA encoding GFP followed by no

electroporation. In combination of natural and fluorescent light, Figure 17A shows adjacent slices of tissue in the vicinity of the injection/needle track site. The photos show no expression without electroporation.

[031] Figures 18A and B are photographs showing combination of natural light and green fluorescence, or fluorescence alone respectively, wherein injection of plasmid DNA encoding GFP was followed by electroporation carried out using a single needle electrode comprising a 23 gauge needle and anode and cathode electrodes having a width of 1/16 the circumference the needle shaft. In this experiment, the electrodes were pulsed at a constant current of 50 mA.

[032] Figures 19A and B are photographs showing combination of natural light and green fluorescence or fluorescence only, wherein injection of plasmid DNA encoding GFP was followed by electroporation carried out using a single needle electrode comprising a 23 gauge needle and anode and cathode electrodes having a width of 1/16 the circumference the needle shaft. In this experiment, the electrodes were pulsed at a constant current of 100 mA.

[033] Figures 20A and B are photographs showing combination of natural light and green fluorescence or fluorescence only, wherein injection of plasmid DNA encoding GFP was followed by electroporation carried out using a single needle electrode comprising a 23 gauge needle and anode and cathode electrodes having a width of 1/4 the circumference the needle shaft. In this experiment, the electrodes were pulsed at a constant current of 50 mA.

[034] Figures 21A and B are photographs showing combination of natural light and green fluorescence or fluorescence only, , wherein injection of plasmid DNA encoding GFP was followed by electroporation was carried out using a single needle electrode comprising a 23 gauge needle and anode and cathode electrodes having a width of 1/4 the circumference the needle shaft. In this experiment, the electrodes were pulsed at a constant current of 100 mA.

[035] Figures 22A and B are photographs showing combination of natural light and green fluorescence or fluorescence only, wherein injection of plasmid DNA encoding GFP was followed by electroporation was carried out using a single needle electrode comprising a 23 gauge needle and anode and cathode electrodes having a width of 1/4 the circumference the needle shaft. In this experiment, the electrodes were pulsed at a constant current of 150 mA.

[036] Figures 23A and B are photographs showing combination of natural light and green florescence or fluorescence only, respectively, wherein injection of plasmid DNA encoding GFP was followed by electroporation was carried out using a single needle electrode comprising electrodes 1mm spacing without fluid delivery embodiment. In this experiment, the electrodes were pulsed at a constant current of 75 mA.

[037] Figures 24A and B are photographs showing combination of natural light and green florescence or fluorescence only, respectively, wherein injection of plasmid DNA encoding GFP was followed by electroporation was carried out using a single needle electrode comprising electrodes 1mm spacing without fluid delivery embodiment. In this experiment, the electrodes were pulsed at a constant current of 150 mA.

[038] Figures 25A and B are photographs showing combination of natural light and green florescence or fluorescence only, respectively, wherein injection of plasmid DNA encoding GFP was followed by electroporation was carried out using a single needle electrode comprising electrodes 1mm spacing without fluid delivery embodiment. In this experiment, the electrodes were pulsed at a constant current of 250 mA.

#### **DETAILED DESCRIPTION OF THE PREFERRED EMBODIMENTS**

[039] In a first embodiment, the invention comprises a device for electroporation of tissue *in vivo* comprising a hollow shaft made of a material capable of insertion into a biologic tissue or organ *in situ* and of delivering therethrough a fluid medium (i.e., a delivery needle shaft), said shaft further comprising at least two electrodes exposed at least in part on an outer surface of said shaft, wherein said electrodes are spaced from one another and situated parallel with respect to one another along said needle shaft. Embodiments for electrodes can employ a variety of electrode structural designs. For example, anode and cathode electrodes can be placed in association with a delivery needle that run parallel to one-another and to the length of the delivery needle such as disclosed in **Figures 1 and 3**, or that are parallel to each other but are spiraled around the needle shaft as depicted in **Figures 2 and 4**. The invention device also includes electric conduits connecting each of said electrodes to an electrical energy source wherein said electrodes when said needle is inserted into a patient tissue are capable of being energized individually, generating an electric field to cells in a treatment zone surrounding said needle sufficient to cause cells along and near a track made by insertion of said needle into said tissue to become reversibly porated so as to allow treatment molecules to enter said cells.

[040] Manufacture of such electrode containing fluid delivery needles can be carried out by any number of well know methods including micromachining such as commonly understood as MEMs technology. For example, a standard hypodermic needle (which can be any gauge such as 20gauge, 21 gauge, 22 gauge, 23 gauge, 24 gauge, 25 gauge 26 gauge, 27 gauge, 28 gauge and 29 gauge) can be coated with an electrically inert material followed by deposition of electrically conductive material such as gold, followed in turn by etching away conductive material in the orientation desired on the surface of the needle. Specifically, generally the process comprises cleaning the hypodermic needle shaft in preparation for deposition of the inert substance, for example, a polymer having properties of evenly adhering to surfaces, such as parylene. Following stripping of the metal shaft, parylene is deposited, such as by vacuum deposition, on to the needle. This is in turn patterned using a laser to deposit electrode conductable material, such as gold, followed in turn by selective removal of the gold to form electrodes in a predetermined pattern on the needle shaft. In the current invention, the use of MEMs technology provides for an ability to manipulate the three dimensional needle and coatings and etchings on a miniature scale. The capability to manufacture a single needle electrode is proven by the photographs of Figures 13A to E. Manufacture can also be carried out by extrusion technology. As depicted in Figures 14A-C, in this aspect the electrodes 202 and 203 (Fig. 14A) are extruded as fine wire filaments with an electrically inert substance such as polyvinylchlorine or the like in a linear fashion. The tip of the needle 204 can be machined or cut to a penetrating tip and at the other end fitted to a hub 200 comprising electrode leads 201a and 201b and a fitting 205 for attachment to a source of fluid medium. Figure 14B depicts an example of a structural embodiment comprising an extruded needle with spiral electrodes and electrode leads 210 and 211.

[041] In a second embodiment, the invention comprises a method for delivering molecules to cells *in vivo* comprising providing to a patient's tissue containing said cells an injection needle further comprising at least two elongate electrodes (i.e., a cathode and an anode) positioned along the needle shaft and at least a reservoir containing said molecules wherein said reservoir and molecules are in fluid communication with a lumen running through said needle shaft, injecting the molecules into said tissue, and energizing the electrodes with electrical energy to provide an electric pulse sufficient to cause cells in the vicinity of the injection site and needle track to become reversibly porated, thereby electroporating said cells for their uptake of said molecules.



**[042]** In a third embodiment, the device provides for electroporation of cells in a narrowly defined location, particularly cells along or near the track made by the injection needle. Generally, the cells considered within the treatment site are those cells lying in a radius around the needle track of about 5mm, more typically about 3mm, and even more particularly about 2mm, and most particularly about 1mm. In a related embodiment, the generation of electric field sufficient for electroporation of cells within said treatment site is a field that weakens outward from the central injection needle such that the treatment site is defined by the inability of the pulse energy to extend into the tissues beyond a certain distance from the electrodes.

**[043]** In a further related embodiment, the invention calls for the novel use of a single elongate probe (which comprises the injection needle and electrodes) for performing *in situ* electroporation of a highly localized set of cells in the tissue.

**[044]** In another embodiment, the invention device may be used with any of a variety of electric pulsing conditions. For example, the electrodes can be charged with at least one pulse of constant current in the range of between 1-400 mAmps, typically between 5-200 mAmps, and more preferably between 20 and 100 mAmps.. In another example, the electrodes can be charged with a voltage pulse in the range of 1 to 100 volts. Further, the electric pulse can be either a monopolar or a bipolar pulse wherein said pulse can be a single, a double or a multiple pulse sequence having various characteristics such as a set voltage drop, variable shaped pulse trains, or pulses employing constant current.

**[045]** In other embodiments, the device and method provide for delivering or transfecting pharmaceutical drugs, proteins, nucleic acids including DNA and RNA, and synthetic modifications thereof as are well known to those of skill in the art, into patient tissues, particular to cells residing in the subcutaneous, intradermal, and subdermal spaces as well as skeletal and striated muscle compartments of a mammalian body, and organs including heart, lung, pancreas, spleen, liver, and organs of the alimentary tract. Once transfected with the selected material, cells will be directly affected by the activity of the drug, or protein or nucleic acid. Where nucleic acids are transfected, typically such nucleic acids are employed for the protein encoded thereby which can be expressed in the cells of the treatment site. Further, the substances can comprise cytokines, chemokines, and immune relevant bioactive molecules including such active molecules as immune modulating molecules selected from the group consisting of IL-1, IL-2, IL-3, IL-4, IL-5, IL-6, IL-7, IL-8, IL-9, IL-10, IL-11, IL-12, GM-CSF, M-CSF, G-CSF, LIF, LT, TGF- $\beta$ , IFN, TNF- $\alpha$ , BCGF, CD2, or ICAM.

[046] In another embodiment, the material to be delivered to the cells can be delivered in a liquid form in a volume of between 0.01ml to 1ml. In one embodiment, nucleic acid encoding a polypeptide can be dissolved in 0.9% sodium chloride (NaCl). The exact solvent, however, is not critical to the invention. For example, it is well known in the art that other solvents such as sucrose are capable of increasing nucleic acid uptake in skeletal muscle. In a related embodiment, the volume to be delivered can be adjusted in relation to the length of the needle (since the length of the needle shaft will determine both the volume of the substance being transported therethrough) and, the needle track made so as to determine the volume of the space available for said substance to fill upon it being expressed through the needle and into the needle track and surrounding tissue. For example, a 2mm long needle can be used for delivering substances to skin layer tissues and provide for injection of a volume in the range of 0.01ml to 0.05ml, while a 5mm long needle can be used to deliver volumes in the range of 0.1ml to 0.15ml, and a 1.5 to 2 cm long needle can be used for delivering volumes in the range of 0.3ml to 0.5ml.

[047] Other substances may also be co-transfected with the molecule of interest for a variety of beneficial reasons. For example, the molecule P199 (Lee, et al. PNAS., 4524-8, 10, 89 (1992)), which is known to seal electroporabilized membranes, may beneficially affect transfection efficiencies by increasing the survival rate of transfected muscle fibers.

[048] With reference to **Figure 6**, the electrode carrying hypodermic needle is inserted into a patient tissue to a desired depth of penetration. The plunger of the attached syringe is activated to inject the volume of liquid containing the selected material for injection, and the electrodes are immediately thereafter, or alternatively simultaneously with the injection of the material, energized with at least one pulse of electric energy sufficient to cause at least some of the cells in the treatment zone to become reversibly porated. Although the syringe plunger is typically activated using animate means, such as by use of the hand, the syringe can also be affixed to a holding device such as disclosed in **Figure 9**, or even an automatic dispensing apparatus, such as a device disclosed in US patent application 10/612,304 filed July 3, 2003 which is herein incorporated in its entirety by reference.

[049] In other embodiments, the invention can be applied to electroporation of cells at various depths from the surface of a body tissue. For example, besides electroporation of cells residing within muscle tissue compartments in which delivery of substances are initiated by injection of materials into the tissue in an orientation approximating 90 degrees from the surface of the tissue, in one embodiment the invention device can be

used to electroporate cells in the subcutaneous, intradermal, or subdermal spaces of skin. It can also be used to electroporate substances into lymph nodes, or tissue layers in other organs such as cardiac and blood vessel tissue. With respect to electroporating cells in any of these locals, use of the device for electroporating cells in such tissue layers can include use of either short needles having a length sufficient for penetrating outer portions of the tissue layers (i.e., skin, subdermal, etc.) for injection and electroporation at approximately a 90 degree angle to the tissue surface, or where a delivery needle is relatively long, such as between 3 and 4 cm, insertion of the single needle can be made at an acute angle to the surface tissue using a holding device as depicted in Figure 9A. This will allow for electroporation of a larger portion of tissue within the desired layer. Further, the acute angle of insertion can be between 3 to 25 degrees of angle from the tissue surface. Such tissue surface can be described as forming generally a flat surface area forming a plane encompassing the site for insertion of the single needle/electrode. As depicted in Figure 9A to D, the syringe can be connected to an attachment means which is designed to hold the syringe at a set angle on a planar guide tray 100 with the needle placed a set distance  $X$  into the tissue as determined based on the predetermined desired depth of insertion of the needle into the tissue. The guide tray with exposed needle is brought into contact with the tissue surface such that the needle inserts the tissue at the prescribed acute angle. After the needle is so inserted and the therapeutic substance expelled from the syringe, the electrodes can be energized to bring about delivery of the injected material into the subcutaneous, intradermal, or subdermal cells. Use of the device at an oblique angle as discussed above can also apply to electroporating various layers of organ tissue.

#### Examples:

[050] The following examples are given to illustrate various embodiments which have been made of the present invention. It is to be understood that the following examples are not comprehensive or exhaustive of the many types of embodiments which can be prepared in accordance with the present invention.

#### Example I.

[051] Turning now to various aspects of the invention, the device can comprise molecule delivery reservoir 20 and electrode needle 10 components as shown for example in (Figure 5). Additional embodiments include sharps cover 11, resilient membrane 12 sealing a portion of the structure comprising the reservoir 20 for uses in filling the reservoir (such as by piercing of a syringe needle), and mechanisms such as dimples 13

and recesses **14** and **14\*** in the reservoir **20** housing structure for keeping the sharps cover **11** in a semi fixed position of either open/retracted (Figure **5C**), or closed/covered (Figures **5A** and **B**). Further embodiments include mechanisms for keeping the plunger **9** in a semi fixed open/retracted or a closed/expelled position, such as, for example, dimples **15** and recesses **16** and **16\***. It should be clear to one of skill in the art that regardless of the method employed to provide for semi fixed positioning of the sharps cover **11** and plunger **9**, such positioning can easily be changed with either animate energy, such as force by hand, or mechanically, such as by an electronically driven actuator. The distal end of the sharps cover **11** can include removably attached thereto a sterility cover **60**. The electrode needle **10** further can comprise a lumen running therethrough ending in tissue piercing tip **22**, and orifice **25** for connecting to the reservoir **20** (See Figure **1**). The injection needle **10** can be of a gage between 18 and 29 standard hypodermic needle gauge sizes. In a preferred embodiment, the delivery needle comprises at least one pair of electrodes, such as electrodes **21a** and **21b** of Figure **1**. The electrodes comprise at least one anode and one cathode electrodes which are in electrical communication with electrode leads **24a** and **24b**. Depending upon the design chosen for any particular invention product, the leads can terminate in a lead terminal **23** (see Figures **3** and **4**, for example), or connect by any other means with lead wires running from the electrode to a source of electrical energy, such as a pulse generator. The needle component **10** can further include a connector **26** (Figures **3** and **4**) for attaching to a hypodermic syringe reservoir, or to a syringe reservoir affixed with a locking mechanism to detachably fasten the needle component **10** to a hypodermic syringe port.

[052] In further embodiments, the reservoir **20** can be manufactured with a predetermined substance for treating a particular condition. Alternatively, the reservoir can be filled with a substance of interest by either drawing such substance into the reservoir through the electrode needle **10** by extracting the plunger **9**, or preferably, the reservoir can first be cleared of the plunger by retracting the plunger to the open position followed by delivering to the reservoir the substance by injecting it into the reservoir via the resilient seal **12**, similarly to the procedure commonly performed in the extracting of drugs from sterile vials into syringes and introducing them into another reservoir.

[053] The delivery needle **10** with its array of electrodes (such as electrodes **21a** and **b**, **31a** and **b**, **51a** and **b** and **52a** and **b**, or **41** and **42**, Figures **1-4**, respectively) can be inserted into the tissue, usually at an approximate 90 degrees to the tissue surface, or alternatively at an acute angle with respect to the tissue surface, and the substance injected

into the needle track and local tissues. The electrodes can be energized using a pulse generator either following the injection of said substance, or can be energized simultaneously with said injection of substance. As depicted in **Figure 6**, when energized with an electric pulse, the electrodes support the generation of an electric field **20** that provides for sufficient energy to cause reversible poration of the cells within said field. The electric field generated is non-uniform in that it exponentially decreases by the distance from the needle track **80** (**Figure 7**). Thus, the electric field sufficient to provide such poration has, depending upon the energy employed, symmetrical lateral dimensions (a) x (b) (shown in **Figure 7**) forming a set diameter of an electroporating electric field which, with respect to the needle track length, forms a defined three dimensional volume. Generally, the poration sufficient electric field has a radius from the electrode needle **10** of between 0 and 5 mm, typically between 0 and 4 mm, and preferably between 0 and 3 mm and most preferably between 0 and 2 mm.

**[054]** As is easily understood by those having skill in the electroporation arts, the field generated by the current invention's single needle electrode, unlike prior electroporation apparatuses, is a non-uniform electric field wherein the field intensity is greater near the needle and diminishes as measured outward from the electrodes. In contrast to the current electrode arrangement, **Figure 8** depicts prior electrode arrangements wherein a uniform electric field is employed across a large volume treatment site. The instant invention is measurably distinct from former concepts that suggested a need to utilize a "uniform" field. Here, the invention employs a non-uniform field which provides for reversible poration of cells to a greater amount near the position of the delivery needle, i.e., the needle tract. This in turn allows a clear benefit to determine the precise location of those cells receiving a known dose of therapeutic materials. This invention through its embodiments therefore provides for "fitting" the electric field to the injection site so as to distribute material to cells more uniformly and confined to a local tissue area as opposed to the variable distribution allowed for with electroporation systems that use a conventional uniform electric field and an outer array of electrodes.

**[055]** With respect to the electrodes generally, they can comprise any metal but preferably are a metal that does not impart a toxicity due to metal ions to the cells of the electroporated tissue. Such materials include gold, tungsten, titanium nitride, platinum, platinum iridium, and iridium oxide. The electrode material can be formed on the delivery tube (i.e., injection needle) such that there is a layer of insulation between the electrodes and the delivery tube as suggested in **Figure 3B**. Alternatively, the needle can comprise a

material that is nonconductive itself eliminating a specific need to insulate the electrodes from the injection tube. In this aspect, the delivery tube can be constructed from any suitable material for insertion into tissue *in situ* that is non-conductive, including, such as a ceramic, or hardened biocompatible plastic, including polyvinylchlorine or the like.

[056] In a further embodiment, the delivery needle/electrode component can be designed such that the electrodes 90 or 101 (Figure 10) are exposed for electroporation only near the tip of the needle as depicted in Figures 9A, and 10A and B. The unexposed portions 91 and 102 of the electrodes can be insulated and run along the delivery needle exterior or internal to the needle. Specifically, where it is desired to position the defined treatment volume (defined by the dimensions of the electroporation electric field imparted to the tissue by the electrode array) in a particular tissue, with the intent of avoiding electroporation of other tissues, electrodes, such as disclosed in Figure 10, can be used, for example, to electroporate deep muscle tissue and avoid other tissues lying closer to the tissue surface, such as fat cell layers, or alternatively to electroporate tissues near the surface, such as for example, subdermal tissues, as suggested in Figure 9A. Such embodiments provide for additional control over placement and size of the treatment volume.

#### Example II

[057] In this example, results are depicted for delivering molecules by reversible poration to cells situated along and near the track formed by the insertion of the invention single hypodermic needle electrode into a tissue.

[058] As depicted in Figures 11A and B, rabbit quadriceps muscle was injected with DNA encoding beta-galactosidase in a bolus comprising 0.2 ml and concentration of 1 mg/ml. The electrodes were pulsed using 2 pulses of 250 mAmps, 20 millise duration. Following electroporation, the beta-galactosidase gene was expressed in cells affected by the electroporation. At day 4 after electroporation, the rabbits were sacrificed and the muscles were prepared in 3 mm thick slices through the site on insertion of the single needle/electrode. Following chemical fixation, the beta galactosidase expressing cells in the muscle slices were visualized by an enzymatic reaction. The arrows in Figure 11A depict the direction of the insertion of the delivery tube into the rabbit muscle. As shown, staining occurs predominantly along the track formed by insertion into the tissue of the needle delivery electrode.

### Example III

[059] This example describes experiments that employ an electroporation device according to embodiments of the invention to deliver DNA encoding green fluorescent protein (GFP) into rabbit quadriceps muscle, the results are shown in Figure 12.

[060] Here, several New Zealand white male rabbits, each weighing 4-5 kg (Perry Scientific, San Diego, California), were each injected with an expression vector (gWizGFP, lot 12311, purchased from Aldevron, LLC, Fargo, ND; see also Gene Therapy Systems, Inc., San Diego, CA) encoding a bright GFP (Cheng, et al. (1996), Nature biotechnology, vol. 14:606-9) the expression of which was under the control of a modified human cytomegalovirus immediate early promoter/enhancer.

[061] Prior to injection, each rabbit was first sedated with acepromazine (1mg/kg) and then anesthetized by intramuscular injection of a mixture of ketamine (35 mg/kg) and xylazine (5 mg/kg) in the presence of glycopyrrolate (0.01 mg/kg), which had been previously administered subcutaneously to prevent uneven heart beating as a result of the ketamine/xylazine treatment. The rabbit was then shaved at the site where the injection was to be made, i.e., into the quadriceps muscle. A hole was poked in the skin covering the muscle by first inserting an 18 gauge needle, and then slightly widened using a scalpel. A single needle electroporation device, made from an 18 gauge needle with two parallel electrodes applied opposite one another to the outer surface of the needle (as depicted in Figure 1), was then slowly inserted into the muscle tissue, periodically pausing to inject DNA every few millimeters to a final insertion depth of approximately 25 mm. A total of 500 ul of DNA-containing solution containing 100 ug gWizGFP was injected into each injection site. Shortly after completing the injection and while the needle/electrode device was still inserted to its final insertion depth, electroporation was commenced.

Specifically, five 250 mA pulses, each of twenty millisecond (ms) duration, were applied to the electroporation needle device at 10Hz intervals (i.e., 100 ms) using an Elgen 1000 (Inovio AS, Oslo, Norway) current-clamped pulse.

[062] Four days post-treatment the animals were humanely euthanized. Skin covering the region of the leg where the vector was delivered was carefully removed, after which each animal was placed at -20°C for about 1 hour. Treated muscle was then removed using a scalpel and then placed at -20°C for another 1 to 2 hrs. The frozen muscle tissue was then sectioned into slices approximately 3 mm thick using a rotating meat slicer. Muscle slices were arranged in plastic trays and examined for GFP expression using a Leica MZ 12 dissection microscope fitted with a UV light and GFP filter combination. Figure 12 is a

representative photo of the results obtained by this analysis, and clearly shows that an electroporation device according to the invention can be used to successfully deliver an agent, for example an expression vector encoding a desired protein that is then expressed in active form, into cells.

#### Example IV

[063] In this example, data for which is shown in Figures 15 and 16, using the invention electrode configuration, plasmids encoding SEAP (pSEAP#3348, Aldevron) and IgG (pLNOH 2hg3 #11765, Aldevron) were electroporated into cells of test animal tissues (i.e., intramuscular injection into the tibialis anterior of the animal) and the expression monitored to prove success of expression in rabbit muscle as well as measuring immune responses against both a “weak” and a “strong” antigen (SEAP and IgG, respectively). In these experiments the SEAP and IgG plasmid were administered at a final concentration of 1 ug/ul.

[064] Animals used were New Zealand White male rabbits 3.5 to 4.5 kg. Electroporation was carried out using an Elgen 1000 (Inovio AS, Oslo, Norway Serial number 009) which further comprised a current-clamped pulse generator (prototype) and a single needle prototype wherein the electrodes ran parallel to the injection track and approximately between 1 mm apart. The electrodes were pulsed for 20 millisecond pulse length with 5 pulses each at 150 mA with a 250 millisecond interval between pulses (i.e., a frequency of about 4 Hz). The electrodes extended into the tissue to about 1.0 cm depth.

[065] The experiments each comprised a two-step delivery process, i.e., injection of the plasmid solution (200 ul) using a 29 gauge insuline syringe with injection during insertion of the needle to distribute DNA at different depths, followed by removal of the injector needle and insertion of the single needle electrode.

[066] As shown in Table I below, each of the IgG and SEAP experiments had two groups of test animals, i.e., one set of animals receiving electroporation and the other not (control)

[067] Table I

Group #	Current	Treatment
1	150-250 mA	100 ul x 2 SEAP 1mg/ml, 100 ul x 2 left tibialis, IgG 1 mg/ml 100 ul x 2 right tibialis
2	No EP	100 ul x 2 SEAP 1mg/ml, 100 ul x 2 left tibialis, IgG 1 mg/ml 100 ul x 2 right tibialis



[068] Samples were taken Day 0, 14 and day 21. The rabbits were then terminated on day 21 with subcutaneous injection of 0.5 ml hypnorm (Hypnorm 0.1 ml/kg) followed by i.v. injection of 1 ml/kg of 10% Pentobarbital in the ear vein.

[069] As is clear from the results of Figures 15 and 16, the levels of antibody titer elicited from the single needle delivery are far in excess of the negative control. Specifically, the two test antigens (IgG and SEAP) elicited titers relative to one another as expected with IgG being a much stronger antigen than SEAP (see titer scale). Both antigens elicited antibody production in the electroporated samples and virtually no antibody production in the non-electroporated samples.

#### Experiment V

[070] In this experiment, prototype MEMs manufactured single needle electrodes were tested in rabbit tissue using a variety of pulsing energies and green fluorescent protein expression. As indicated in Table II, three different electrode embodiments were tested, (1) a single needle electrode in which the anode and cathode electrodes were applied to a 23 gauge needle at 1/16 the circumference of the needle each and applied to the full length of the needle by MEMs technology (Figures 13D-E), (2) a single needle electrode wherein the electrodes are 1/4<sup>th</sup> the circumference of the needle shaft each (Figures 13A-C), and (3) a single needle arrangement wherein the electrodes are 1 mm apart without a fluid medium delivery tube. As shown in Table II, the various combinations of pulsing were performed.

[071] The protocol used for each animal in this experiment comprised injecting the GFP plasmid at the noted concentrations, electroporating the tissue using an embodiment of the single needle electrode, followed by sacrificing of the animals and performing tissue preparation by slicing the treated muscle in adjacent slices and observing fluorescence. Generally, due to the difficulty of slicing the tissue so as to retrieve slices parallel to the injection track, GFP fluorescence in the figure photos often show up as circles or ellipses. These fluorescence patterns prove that the single needle concept is functional and provides for electroporation of tissue at very low voltages and relative electric current in defined locations surrounding the needle track and within the tissue.

[072] Table II

Electrode design	Tissue site	Constant current	Voltage (average V)	Number of pulses	pGFP DNA concentration/volume
Electrodes 1/4 shaft circumference	Quadriceps	0.0	0.0	0.0	0.2 mg/ml
Electrodes 1/16 shaft circumference	Quadriceps	50 mA	8	2	0.2 mg/ml
	Quadriceps	100 mA	18	2	0.2 mg/ml
Electrodes 1/4 shaft circumference	Quadriceps	50 mA	11	2	0.2 mg/ml
	Quadriceps	100 mA	15	2	0.2 mg/ml
	Quadriceps	150 mA	20	2	0.2 mg/ml
	Quadriceps	250 mA	33	2	0.2 mg/ml
Electrodes 1mm spacing without fluid delivery embodiment	Tibialis	75 mA	13	2	1.0 mg/ml
	Tibialis	150 mA	18	2	1.0 mg/ml
	Tibialis	250 mA	28	2	1.0 mg/ml
	Quadriceps	150-200	20	2	1.0 mg/ml
	Quadriceps	250-500	40	2	1.0 mg/ml
	Quadriceps	600-1000 mA	50	2	1.0 mg/ml

[073] Figures 17A and B show both natural light and florescent light, respectively, photographs of GFP expression following injection of plasmid DNA encoding GFP with no electroporation. As indicated, there is virtually no green florescent protein expression. Thus, it is clear that without electroporation there is not sufficient uptake and expression of the desired gene.

[074] With respect to electroporation *in situ* using the 1/16 width electrode model, the ability to express electroporated GFP is shown in Figures 18A and B and 19A and B. Figures 18A and B show GFP expression results upon electroporation with a constant current of 50 mA, while Figures 19A and B show electroporation at 100 mA.

[075] For GFP expression using the 1/4 circumference single needle electrode, results are provided in Figures 20A and B, 21A and B, and 22A and B, wherein electroporation was carried out using 50, 100, and 150 mA, respectively.

[076] GFP expression was also testing using an embodiment wherein the single needle electrode did not comprise a fluid delivery tube associated with the electrodes. As shown in Figures 23A and B, 24A and B, and 25A and B, this invention device embodiment was tested at 75, 150, and 250 mA each at constant current. Here, the amount of GFP plasmid was five times the concentration of the experiments shown in Figures 19-22.

Consequently, the treatment zone appears more readily.

[077] All of the compositions and methods disclosed and claimed herein can be made and executed without undue experimentation in light of the present disclosure. While the compositions and methods of this invention have been described in terms of preferred embodiments, it will be apparent to those of skill in the art that variations may be applied to the compositions and methods and in the steps or in the sequence of steps of the method described herein without departing from the spirit and scope of the invention. More specifically, the described embodiments are to be considered in all respects only as illustrative and not restrictive. All similar substitutes and modifications apparent to those skilled in the art are deemed to be within the spirit and scope of the invention as defined by the appended claims.

[078] All patents, patent applications, and publications mentioned in the specification are indicative of the levels of those of ordinary skill in the art to which the invention pertains. All patents, patent applications, and publications, including those to which priority or another benefit is claimed, are herein incorporated by reference to the same extent as if each individual publication was specifically and individually indicated to be incorporated by reference.

[079] The invention illustratively described herein suitably may be practiced in the absence of any element(s) not specifically disclosed herein. Thus, for example, in each instance herein any of the terms “comprising”, “consisting essentially of”, and “consisting of” may be replaced with either of the other two terms. The terms and expressions which have been employed are used as terms of description and not of limitation, and there is no intention that use of such terms and expressions imply excluding any equivalents of the features shown and described in whole or in part thereof, but it is recognized that various modifications are possible within the scope of the invention claimed. Thus, it should be understood that although the present invention has been specifically disclosed by preferred embodiments and optional features, modification and variation of the concepts herein disclosed may be resorted to by those skilled in the art, and that such modifications and variations are considered to be within the scope of this invention as defined by the appended claims.

\* \* \*

What is claimed is:

1. A device for electroporation of tissue in vivo for delivering therapeutic substances into cells of said tissue comprising:
  - a. at least one single electroporating needle capable of penetrating said tissue, said needle comprising:
    - an elongated hollow shaft adapted for delivery of a fluid comprising a therapeutic substance to said tissue, said shaft having a length running from one end of the needle to a tip of the needle at the other end of the needle, and
    - at least two electrodes exposed along an outer surface of said shaft that are adapted to deliver a generally cylindrical electric field, said exposure selected from electrodes spaced and electrically isolated from one another and situated linear and parallel to one another and parallel to the length of said shaft, or spiraling and parallel to one another along the length of said shaft; and
  - b. electric conduits capable of connecting each of said electrodes to an electrical energy source, wherein when said shaft is inserted into said tissue and said electrodes are energized by said energy source, said electrodes are capable of generating an electric field in a treatment zone surrounding said shaft sufficient to cause cells in said treatment zone to become reversibly porated so as to allow said cells to take up said therapeutic substance.
2. The device according to claim 1 further comprising an expandable or contractible reservoir in fluid communication with said hollow shaft.
3. The device according to claim 2 wherein said reservoir comprises a syringe.
4. The device according to claim 3 wherein said reservoir has a variable volume capacity selected from the group consisting of 0.0 to 0.5 ml, 0.0 to 1 ml, 0.0 to 3 ml, and 0.0 to 5 ml.
5. The device according to any one of claims 1 to 4 wherein said electrical energy source is an electroporation pulse generator.
6. The device according to claim 5 wherein said electroporation pulse generator

is capable of generating electric pulses wherein the average voltage can range between 1 to 200 V.

7. The device according to claim 5 or 6 wherein said electroporation pulse generator is capable of generating electric pulses having a current of 1 mAmp to 400 mAmps.

8. The device according to claim 7 wherein said current is within a range selected from the group consisting of between 10 and 40 mAmps, 25 and 100 mAmps, 50 and 150 mAmps, 125 and 200 mAmps, 175 and 250 mAmps, 225 and 300 mAmps, 250 and 300 mAmps, and 300 and 400 mAmps.

9. The device according to any one of claims 6 to 8 wherein said electroporation pulse generator is capable of generating electric pulses having a frequency selected from the group consisting of 1 to 10,000 Hz.

10. The device according to any one of claims 6 to 9 wherein said electroporation pulse generator is capable of generating electric pulses having a time length selected from the group consisting of 0.1 us to 1000 ms.

11. The device according to any one of the preceding claims wherein said hollow shaft is a hypodermic needle sized to the gauge of an injection needle selected from the group consisting of 20 gauge, 21 gauge, 22 gauge, 23 gauge, 24 gauge, 25 gauge, 26 gauge, 27 gauge, 28 gauge and 29 gauge.

12. The device according to any one of the preceding claims wherein said hollow shaft is electrically insulated from each electrode.

13. The device according to any one of the preceding claims wherein said tissue comprises any tissue type or organ selected from the group consisting of skin, subcutaneous tissue, intradermal tissue, subdermal tissue, skeletal muscle, striated muscle, smooth muscle, organs, heart, breast, lung, pancreas, liver, spleen and mucosa.

14. A method of electroporating cells of tissue in vivo with a therapeutically useful composition comprising:

a. providing at least one single electroporating needle capable of penetrating said tissue, said needle comprising:

an elongated hollow shaft adapted for delivery of a fluid comprising a therapeutic substance to said tissue, said shaft having a length running from one end of the needle to a tip of the needle at the other end of the needle, and

at least two electrodes exposed along an outer surface of said shaft that are adapted to deliver a generally cylindrical electric field, said exposure selected from electrodes spaced and electrically isolated from one another and situated linear and parallel to one another and parallel to the length of said shaft, or spiraling and parallel to one another along the length of said shaft; and

providing electric conduits capable of connecting each of said electrodes to an electrical energy source;

b. providing a reservoir containing said composition, said reservoir and composition being in fluid communication with a lumen running through said shaft;

c. forming a channel in a preselected treatment site on a patient by inserting said shaft into said tissue in vivo in said patient;

d. injecting said composition from said reservoir through said lumen into said treatment site comprising said channel;

e. providing a source of electrical energy to each of said electrodes sufficient to cause reversible poration of cells in said treatment site; and

f. activating said source of electrical energy to provide an electric pulse thereby electroporating said cells for their uptake of said composition.

15. The method according to claim 14 wherein said composition comprises any of a drug, a nucleic acid, an antigen, a nucleic acid encoding an expressible antigen, a nucleic acid encoding an expressible immune modulating molecule.

16. The method according to claim 15 wherein said immune modulating molecule is a cytokine or a chemokine.

17. The method according to claim 16 wherein said immune modulating molecule is selected from the group consisting of IL-1, IL-2, IL-3, IL-4, IL-5, IL-6, IL-7, IL-8,

IL-9, IL-10, IL-11, IL-12, GM-CSF, M-CSF, G-CSF, LIF, LT, TGF- $\beta$ , IFN, TNF- $\alpha$ , BCGF, CD2, or ICAM.

18. The method according to any one of claims 14 to 17 wherein said cells comprise cells of a live patient selected from the group consisting of subcutaneous cells, intradermal, subdermal cells, skeletal muscle cells, striated muscle cells, smooth muscle cells, organ cells, breast tissue cells, pancreas cells, spleen cells, heart cells, liver cells and mucosa cells.

19. The method according to any one of claims 14 to 18 wherein said electrodes comprise gold and/or titanium.

20. The method according to any one of claims 14 to 19 wherein said treatment site is located on a patient thigh, arm, or torso.

21. The method according to any one of claims 14 to 20 wherein said composition is injected in a total volume selected from the group consisting of 0.01 ul, 50 ul, 100 ul, 150 ul, 200 ul, 250 ul, 300 ul, 400 ul, and 500 ul.

22. The method according to any one of claims 14 to 21 wherein said composition is injected in a total active ingredient concentration selected from the group consisting of 2 ng/ml to 3 mg/ml.

23. The method according to any one of claims 14 to 22 wherein said composition is injected either before or simultaneous with activating said energy source sufficient to reversibly porate said cells.

24. The method according to claim 23 wherein said composition after injection resides in and around said channel formed by said shaft insertion into said tissue.

25. The method according to any one of claims 14 to 25 wherein said composition is electroporated into said cells of said treatment site.

26. The method according to claim 21 wherein said treatment site comprises a

zone of tissue/cells surrounding a track in said tissue made by said needle and extending radially out from said tract a distance selected from the group consisting of 1 mm, 2 mm, 3 mm, 4 mm and 5 mm.

27. The method according to any one of claims 14 to 26 wherein said source of electrical energy is an electroporation pulse generator.

28. The method according to claim 27 wherein said electroporation pulse generator is pulsed such that the nominal voltage is between 1 to 200 V.

29. The method according to claim 27 or 28 wherein said electroporation pulse generator is pulsed at a constant current selected from the group consisting of 1 to 400 mAmps.

30. The method according to claim 29 wherein said current is within a range selected from the group consisting of between 10 and 40 mAmps, 25 and 100 mAmps, 50 and 150 mAmps, 125 and 200 mAmps, 175 and 250 mAmps, 225 and 300 mAmps, 250 and 300 mAmps, and 300 and 400 mAmps.

31. The method according to any one of claims 27 to 30 wherein said electroporation pulse generator is pulsed at a frequency selected from between the range 1 to 10,000 Hz.

32. The method according to any one of claims 27 to 31 wherein said electroporation pulse generator is pulsed for a time length between about 0.1 us to 1000 ms.

33. The method according to any one of claims 15 to 32 wherein said shaft is sized to a gauge of an injection needle selected from the group consisting of 20 gauge, 21 gauge, 22 gauge, 23 gauge, 24 gauge, 25 gauge, 26 gauge, 27 gauge, 28 gauge and 29 gauge.

34. The device according to any one of claims 1 to 13, wherein the electrodes are disposed along opposite sides of said shaft.



35. The device according to any one of claims 1 to 13, wherein each electrode has a length substantially equal to the length of said shaft.

36. The device according to any one of claims 1 to 13, wherein the electrodes run the entire length of said shaft.

37. A device for electroporation of tissue in vivo for delivering therapeutic substances into cells of said tissue, or a method of electroporating cells of tissue in vivo with a therapeutically useful composition, substantially as herein described with reference to the accompanying drawings.

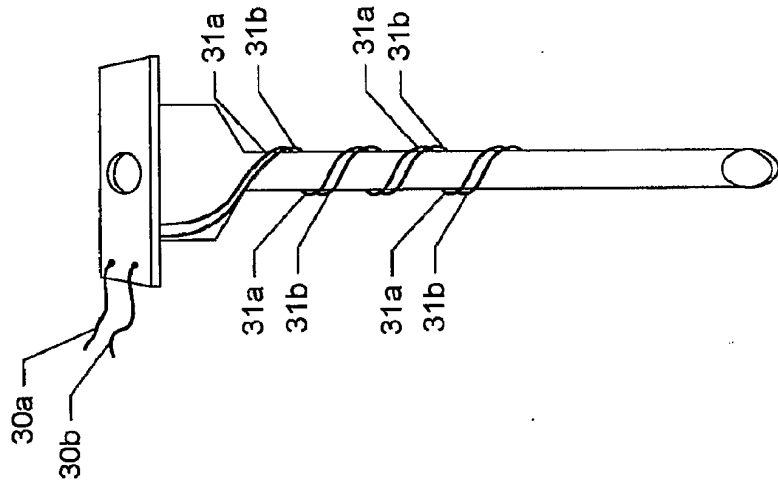


Fig. 1

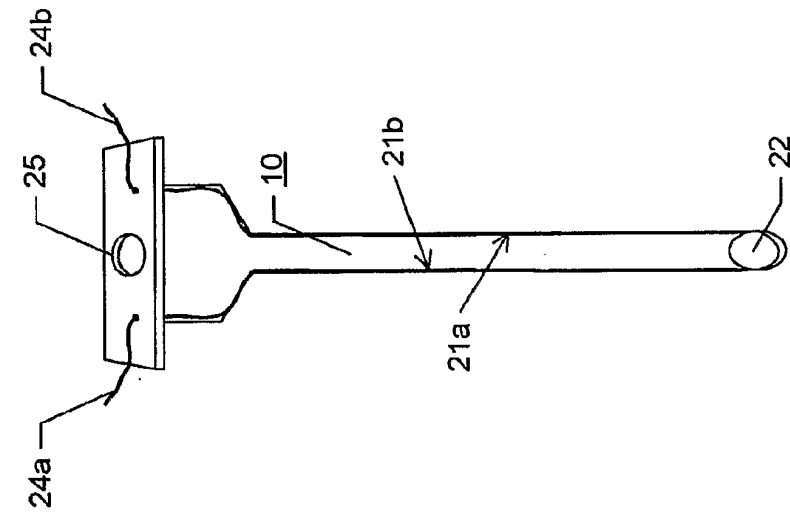


Fig. 2

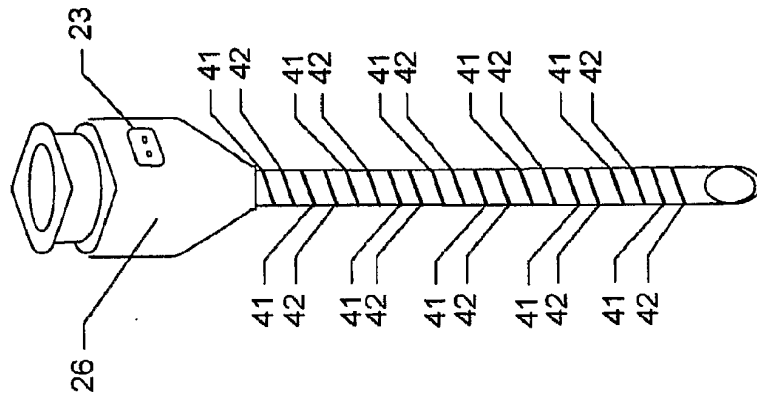


Fig. 4

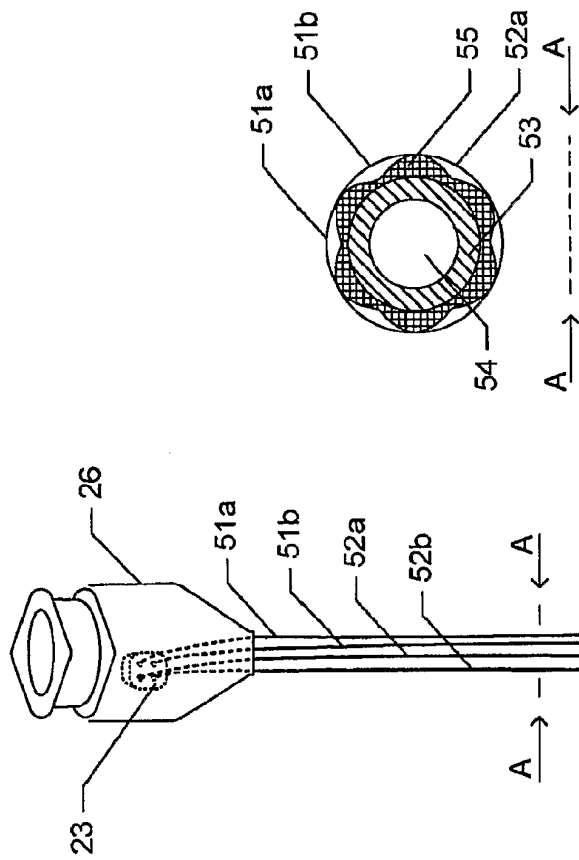


Fig. 3B

Fig. 3A

3/19

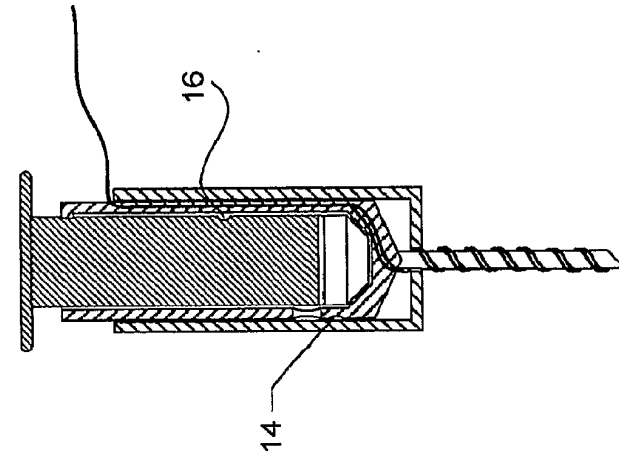


Fig. 5C

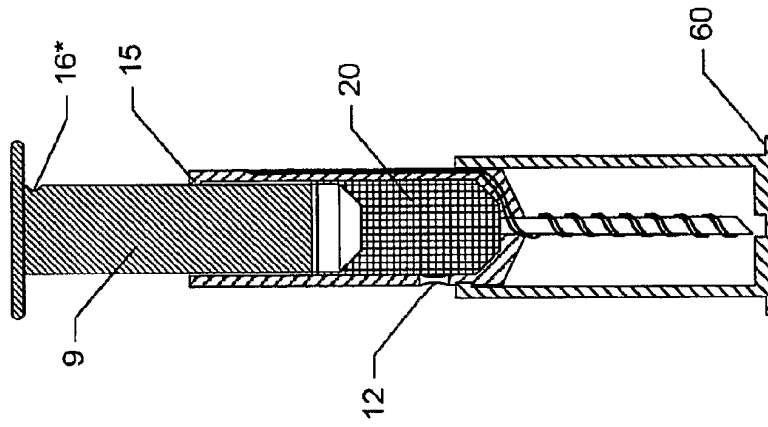


Fig. 5B

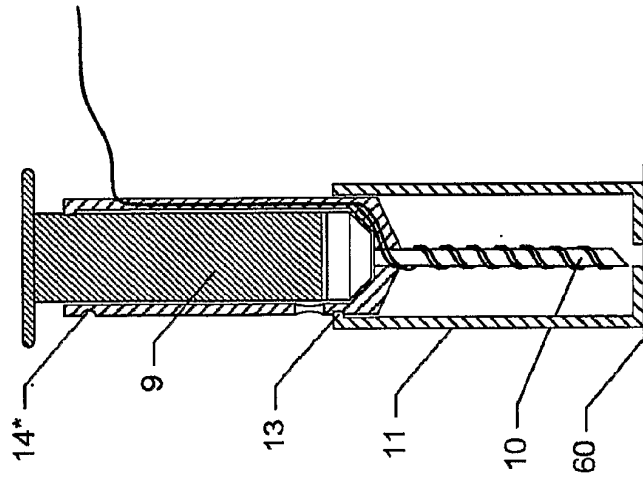


Fig. 5A

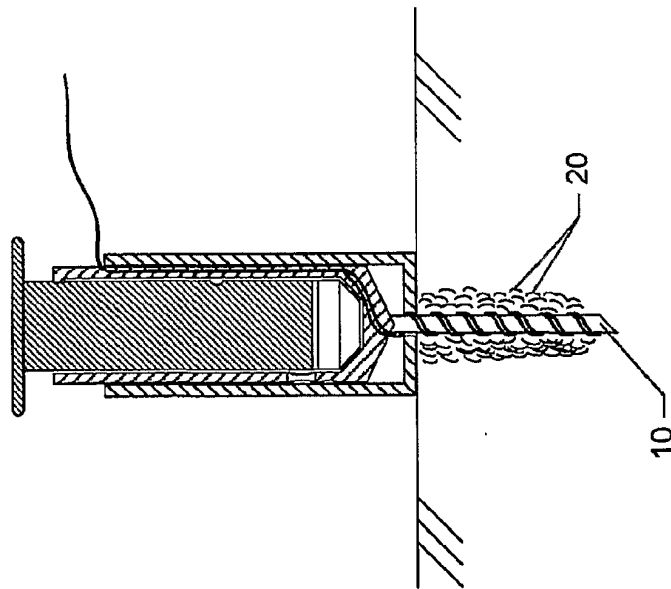


Fig. 6

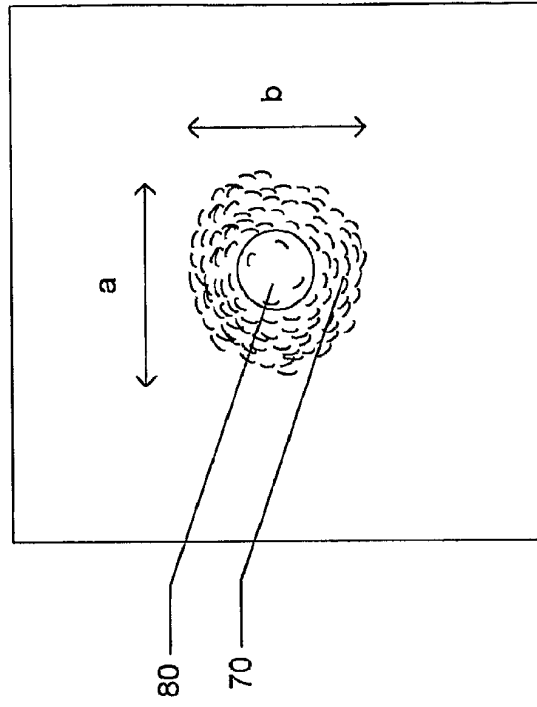
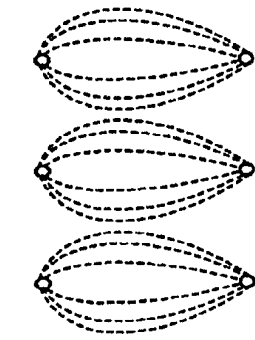
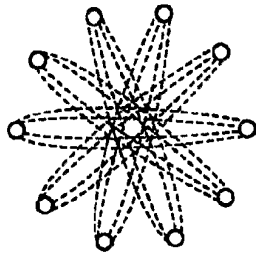


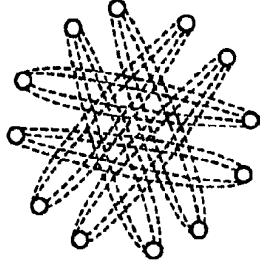
Fig. 7



**Fig. 8A**

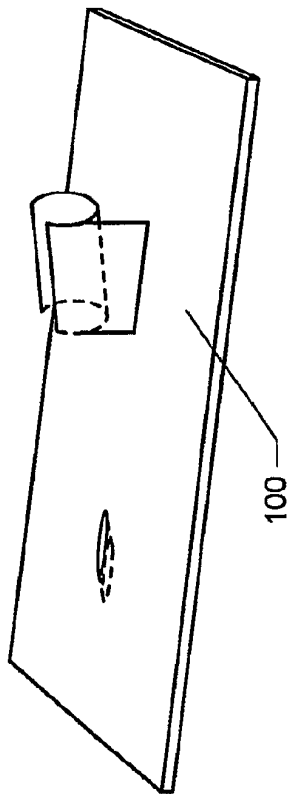


**Fig. 8B**

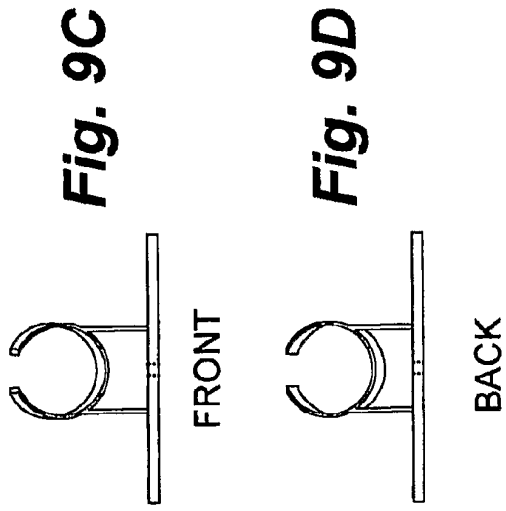


**Fig. 8C**

6/19



**Fig. 9B**

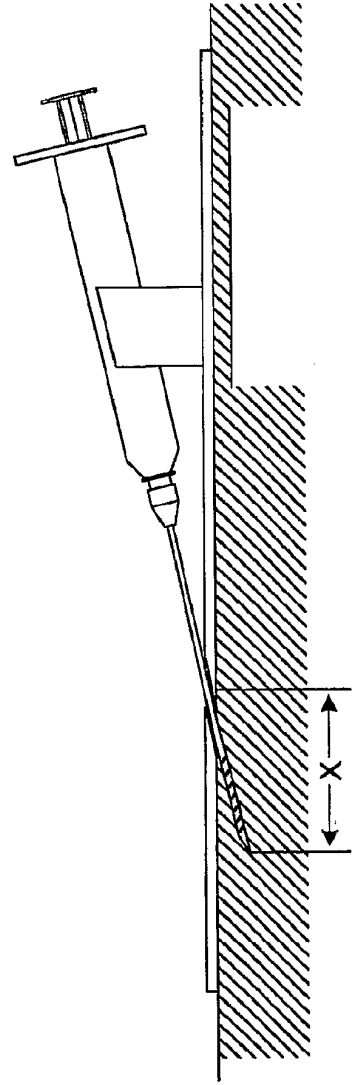


**Fig. 9C**

FRONT

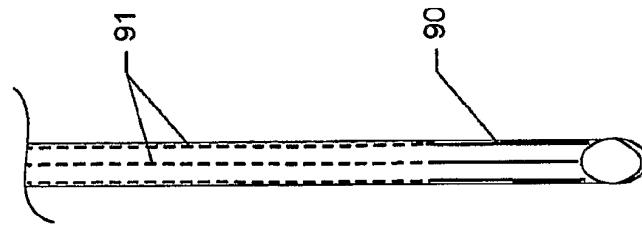
**Fig. 9D**

BACK

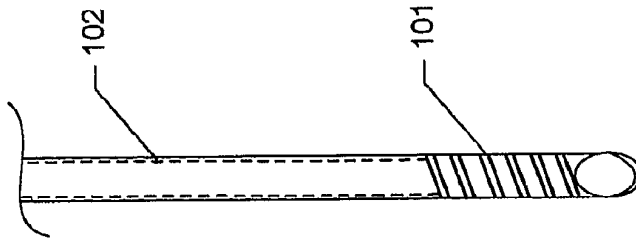


**Fig. 9A**

7/19



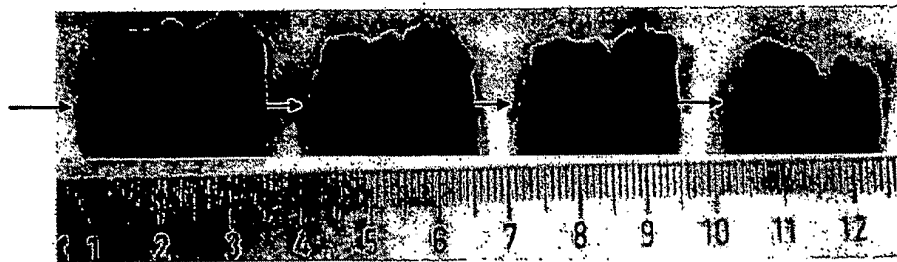
**Fig. 10A**



**Fig. 10B**



8/19

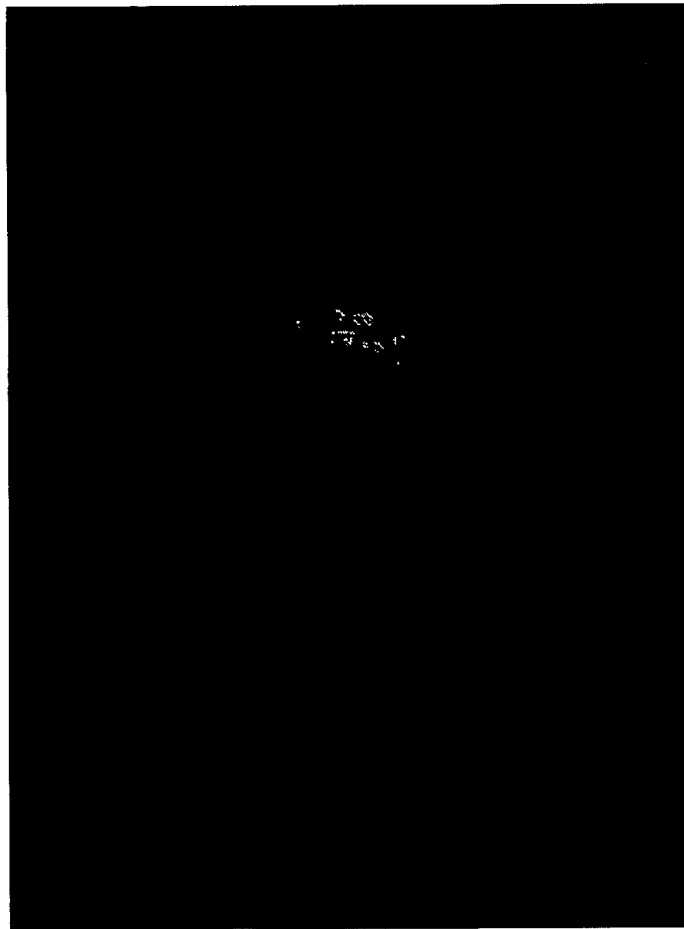


**Fig. 11A**



**Fig. 11B**

9/19

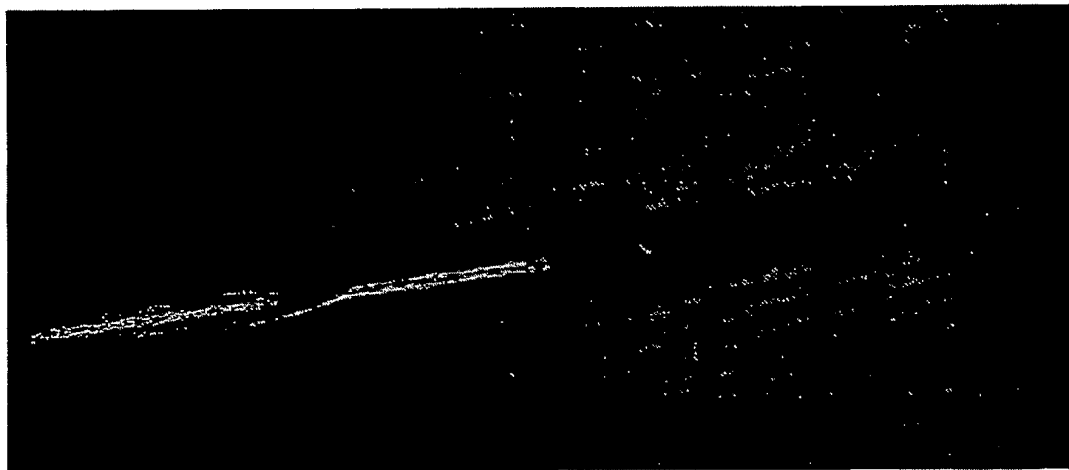


**Fig. 12**

10/19

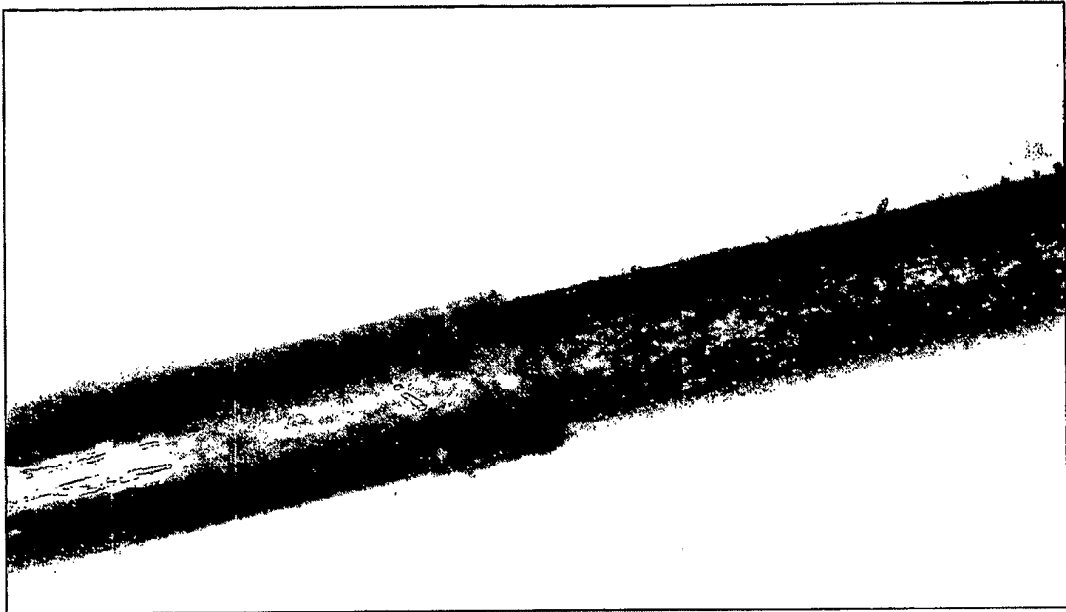


***Fig. 13A***

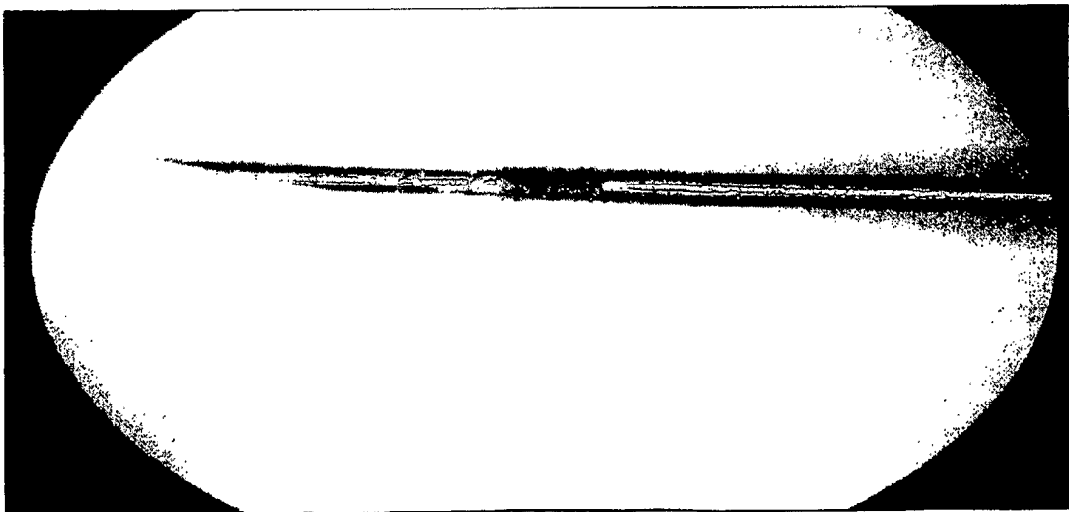


***Fig. 13B***

11/19

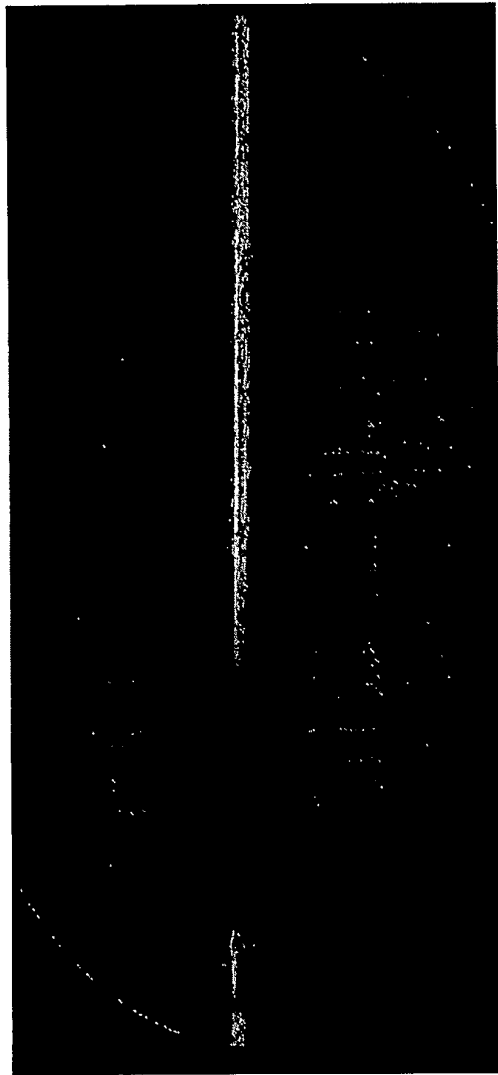


**Fig. 13C**



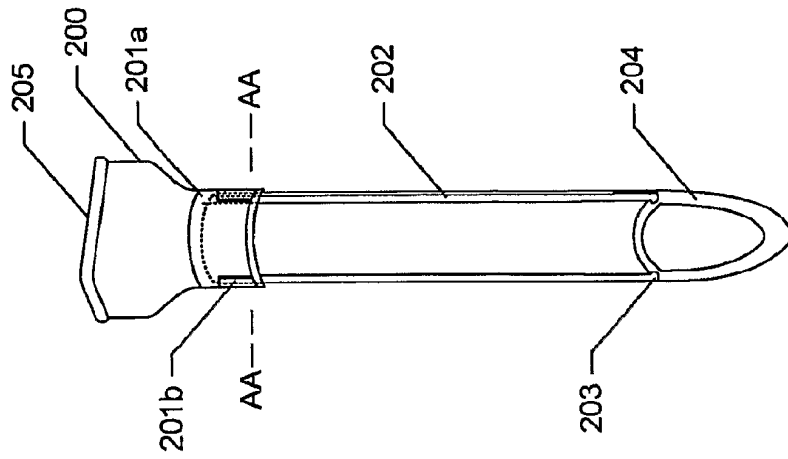
**Fig. 13D**

12/19

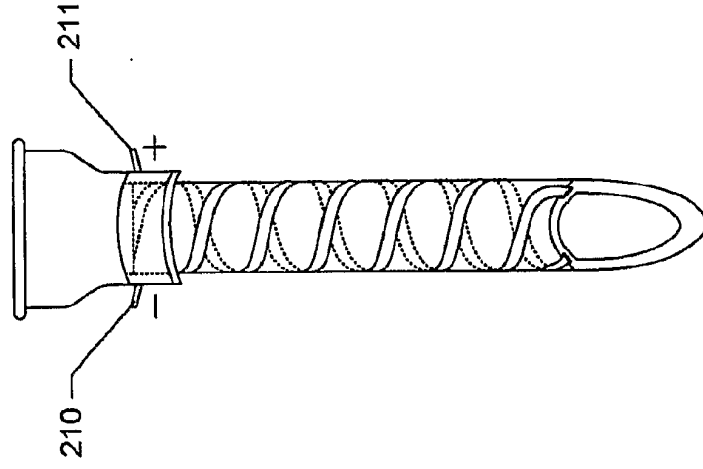


**Fig. 13E**

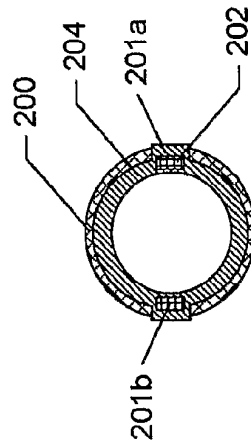
13/19



**Fig. 14A**

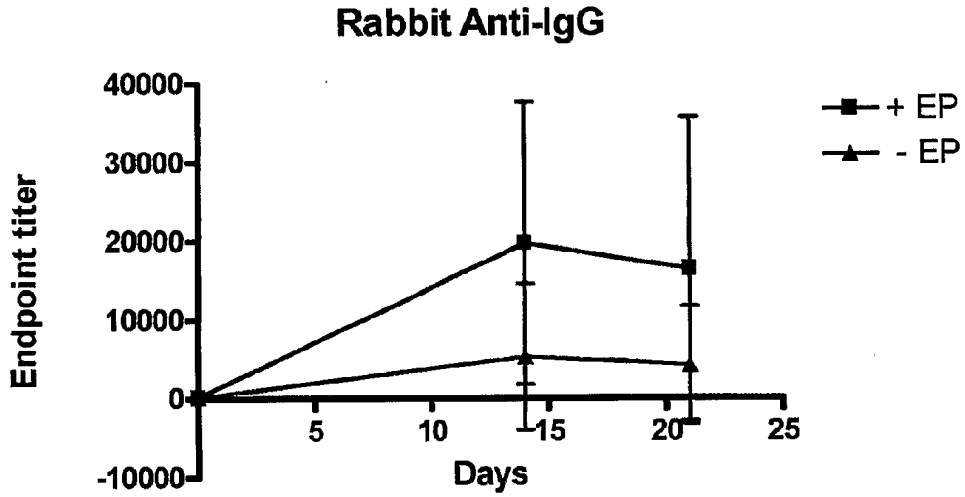


**Fig. 14B**

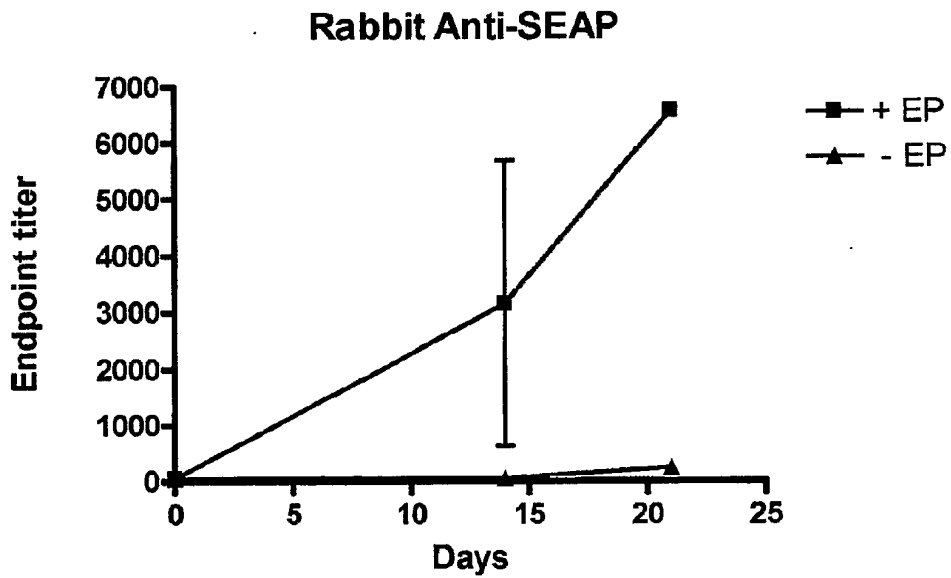


**Fig. 14C**

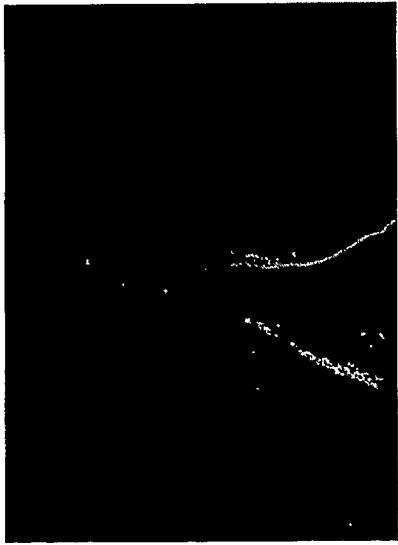
14/19



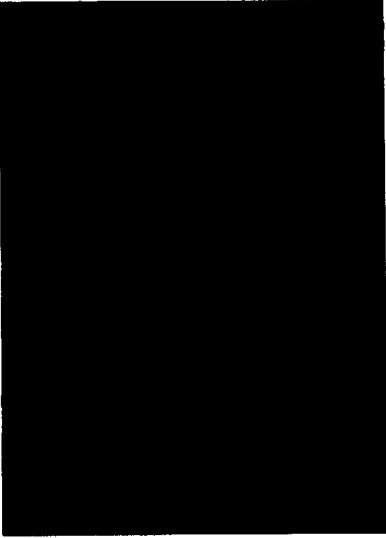
**Fig. 15**



**Fig. 16**



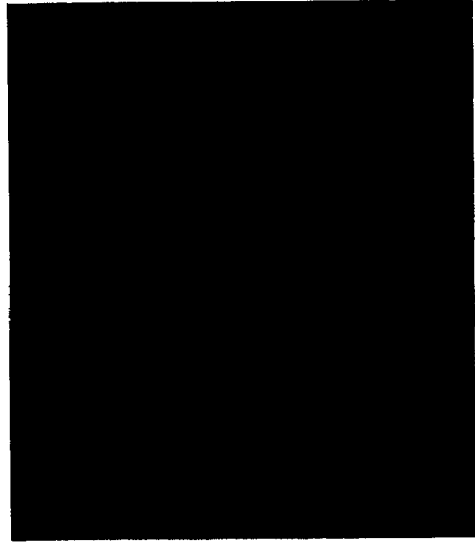
**Fig. 17A**



**Fig. 17B**



**Fig. 18A**

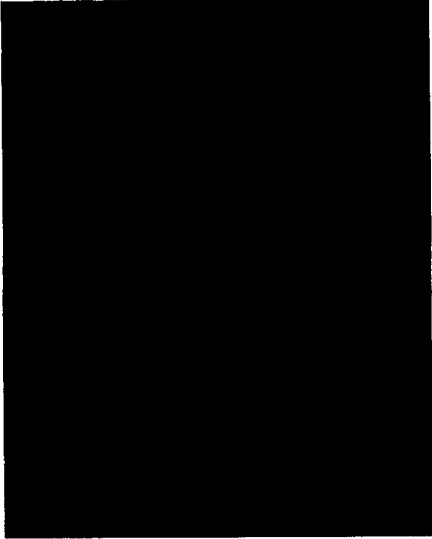


**Fig. 18B**

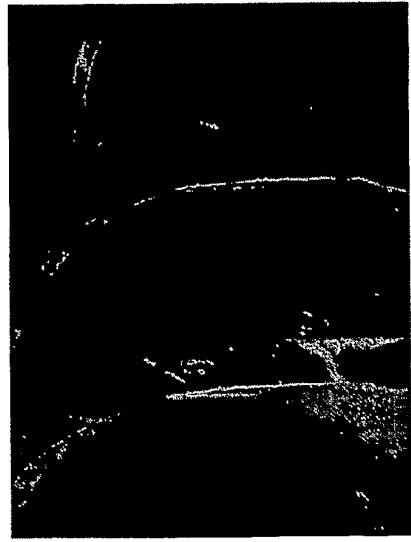




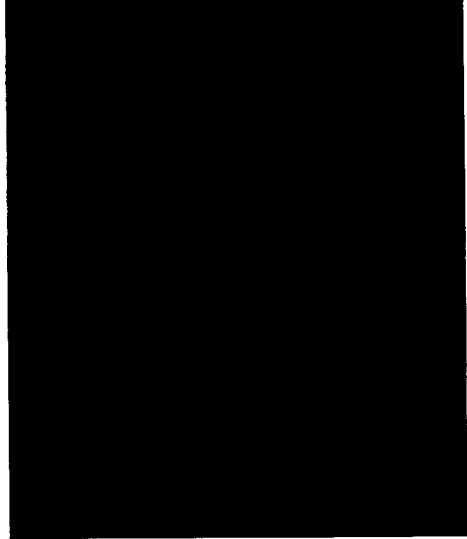
**Fig. 19A**



**Fig. 19B**

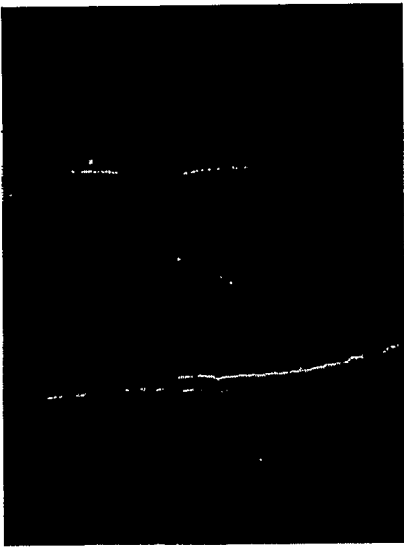


**Fig. 20A**

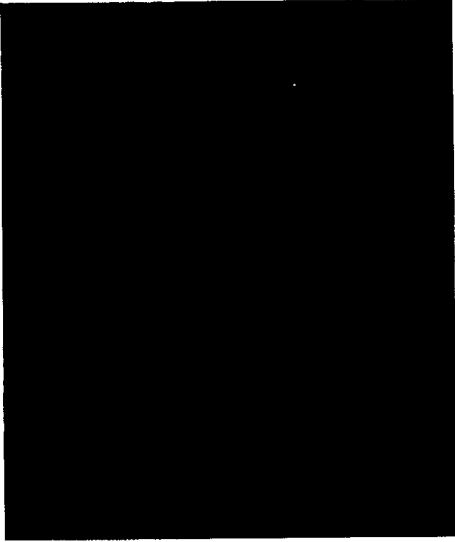


**Fig. 20B**

17/19



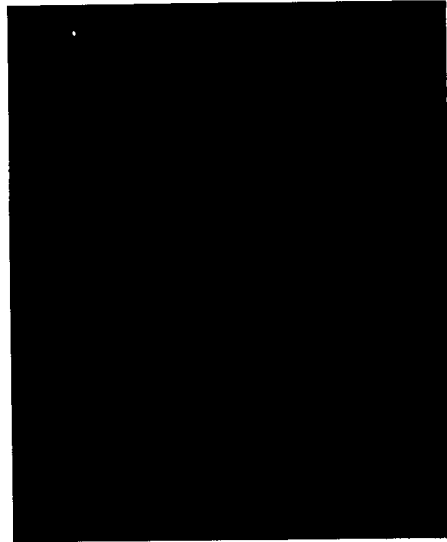
**Fig. 21A**



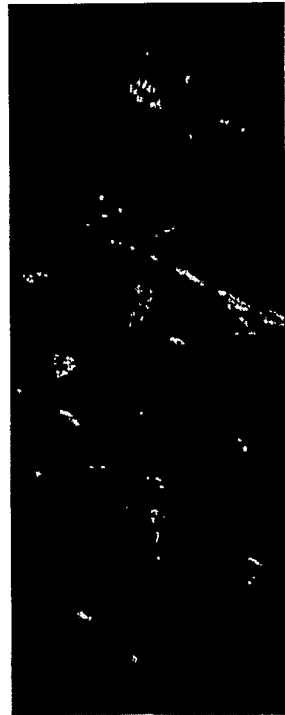
**Fig. 21B**



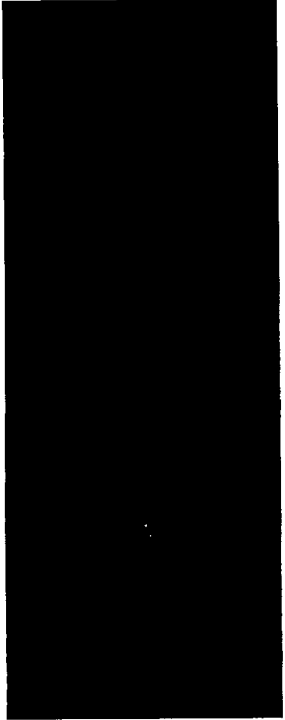
**Fig. 22A**



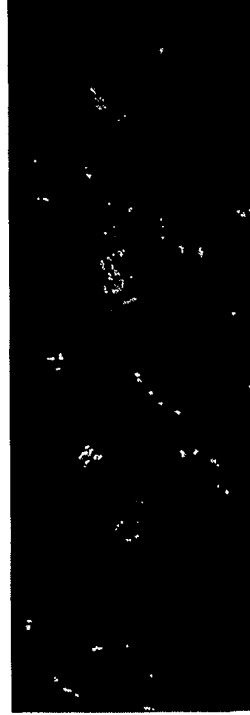
**Fig. 22B**



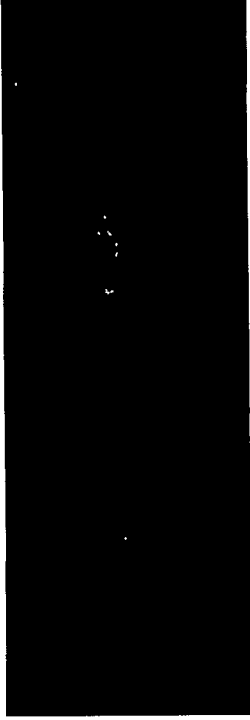
**Fig. 23A**



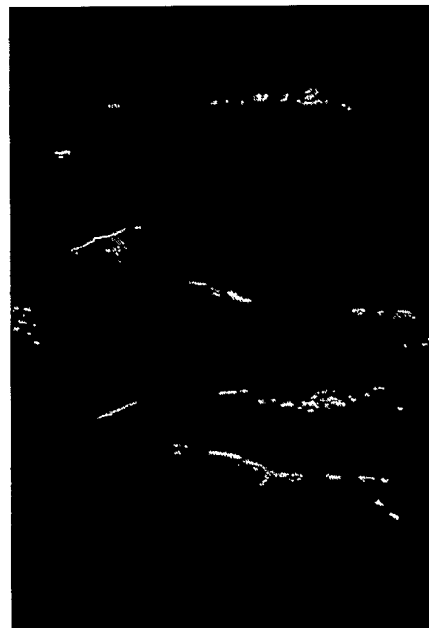
**Fig. 23B**



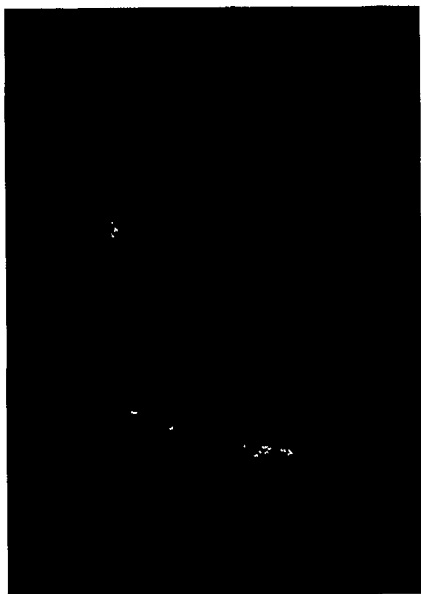
**Fig. 24A**



**Fig. 24B**



**Fig. 25A**



**Fig. 25B**