

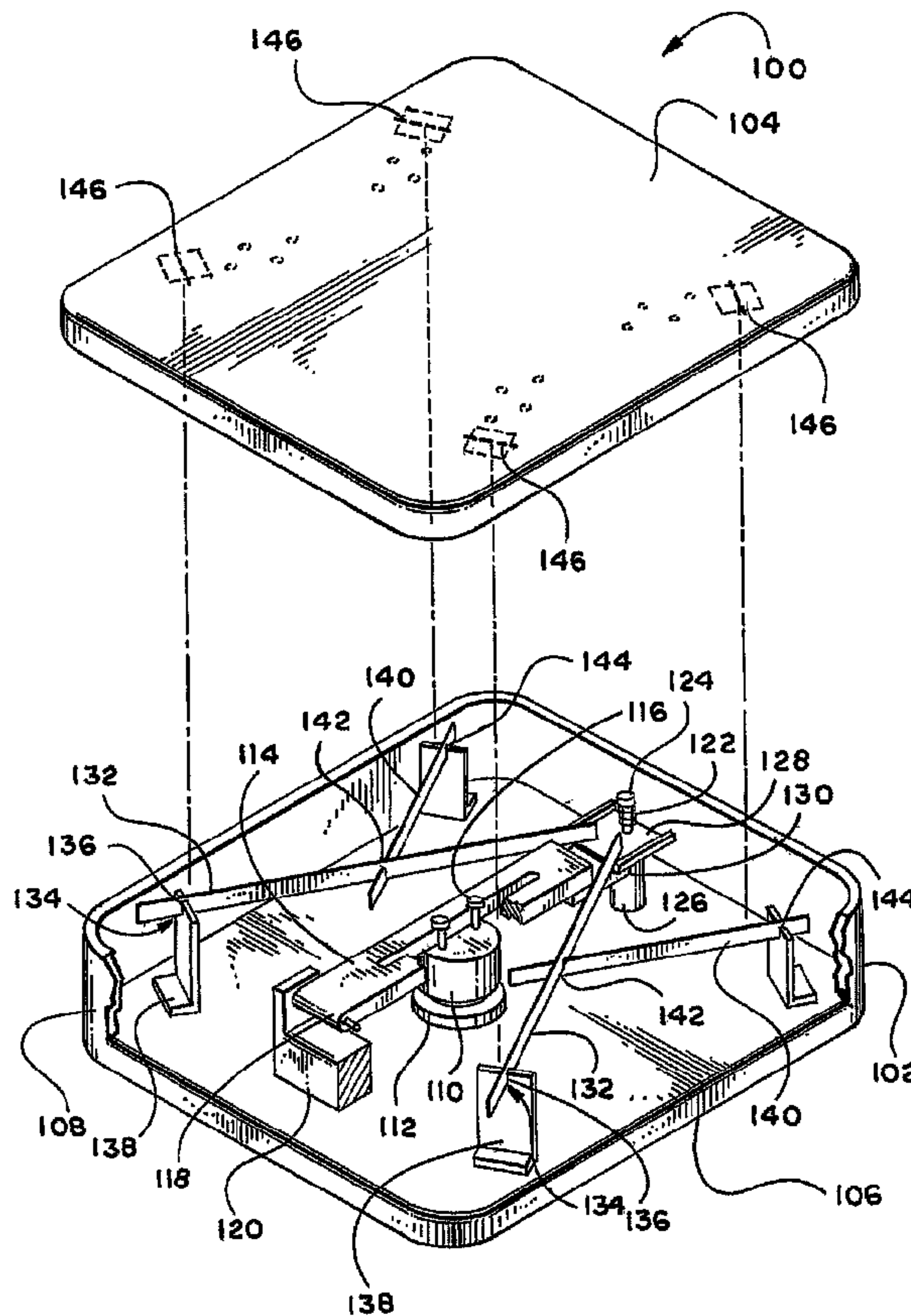

(86) Date de dépôt PCT/PCT Filing Date: 2003/10/30
 (87) Date publication PCT/PCT Publication Date: 2004/05/27
 (45) Date de délivrance/Issue Date: 2008/01/22
 (85) Entrée phase nationale/National Entry: 2005/04/29
 (86) N° demande PCT/PCT Application No.: US 2003/034579
 (87) N° publication PCT/PCT Publication No.: 2004/043324
 (30) Priorité/Priority: 2002/11/08 (US10/290,839)

(51) Cl.Int./Int.Cl. *A61H 1/00* (2006.01)
 (72) Inventeur/Inventor:
 KROMPASICK, DONALD E., US
 (73) Propriétaire/Owner:
 JUVENT, INC., US
 (74) Agent: MOFFAT & CO.

(54) Titre : APPAREILS ET PROCÉDES DE TRAITEMENT THERAPEUTIQUE DE TISSUS LESES, DE FRACTURES OSSEUSES, DE L'OSTEOPENIE OU DE L'OSTEOPOROSE
 (54) Title: APPARATUSES AND METHODS FOR THERAPEUTICALLY TREATING DAMAGED TISSUES, BONE FRACTURES, OSTEOPENIA, OR OSTEOPOROSIS



(57) Abrégé/Abstract:

Systems and methods for therapeutically treating damaged tissues, bone fractures, osteopenia, or osteoporosis. Systems and methods according to various embodiments of the invention include an oscillating platform for therapeutically treating damaged

(57) **Abrégé(suite)/Abstract(continued):**

tissues, bone fractures, osteopenia, osteoporosis, or other tissue conditions in a body. The oscillating platform supports a body. The oscillating platform includes an upper plate; a lower plate; a drive lever supported from the lower plate; a damping member in contact with the drive lever; and a distributing lever arm in contact with the upper plate. The drive lever actuates at a first predetermined frequency. Next, the damping member damps the actuation of the drive lever, creating an oscillating force at a second predetermined frequency. A portion of the oscillating force transfers from the damping member to the distributing lever arm. Then a portion of the oscillating force transfers from the distributing lever arm to the platform so that the body on the platform receives an oscillation at a frequency effective for treatment of damaged tissues, bone fractures, osteopenia, osteoporosis, or other tissue conditions.

(12) INTERNATIONAL APPLICATION PUBLISHED UNDER THE PATENT COOPERATION TREATY (PCT)

(19) World Intellectual Property
Organization
International Bureau



(43) International Publication Date
27 May 2004 (27.05.2004)

PCT

(10) International Publication Number
WO 2004/043324 A1

- (51) International Patent Classification⁷: A61H 1/00, 23/02
- (21) International Application Number:
PCT/US2003/034579
- (22) International Filing Date: 30 October 2003 (30.10.2003)
- (25) Filing Language: English
- (26) Publication Language: English
- (30) Priority Data:
10/290,839 8 November 2002 (08.11.2002) US
- (71) Applicant: EXOGEN, INC. [US/US]; 1450 Brooks Road, Memphis, TN 38116 (US).
- (72) Inventor: TALISH, Roger, J.; 5 Harman Court, Hillsborough, NJ 08844 (US).
- (74) Agent: CARTER, David, M; Carter, Deluca, Farrell and Schmidt, LLP, 445 Broad Hollow Road, Suite 225, Melville, NY 11747 (US).
- (81) Designated States (*national*): AE, AG, AL, AM, AT, AU, AZ, BA, BB, BG, BR, BW, BY, BZ, CA, CH, CN, CO, CR, CU, CZ, DE, DK, DM, DZ, EC, EE, ES, FI, GB, GD, GE, GH, GM, HR, HU, ID, IL, IN, IS, JP, KE, KG, KP, KR, KZ, LC, LK, LR, LS, LT, LU, LV, MA, MD, MG, MK, MN, MW, MX, MZ, NI, NO, NZ, OM, PG, PH, PL, PT, RO, RU, SC, SD, SE, SG, SK, SL, SY, TJ, TM, TN, TR, TT, TZ, UA, UG, UZ, VC, VN, YU, ZA, ZM, ZW.
- (84) Designated States (*regional*): ARIPO patent (BW, GH, GM, KE, LS, MW, MZ, SD, SL, SZ, TZ, UG, ZM, ZW), Eurasian patent (AM, AZ, BY, KG, KZ, MD, RU, TJ, TM), European patent (AT, BE, BG, CH, CY, CZ, DE, DK, EE, ES, FI, FR, GB, GR, HU, IE, IT, LU, MC, NL, PT, RO, SE, SI, SK, TR), OAPI patent (BF, BJ, CF, CG, CI, CM, GA, GN, GQ, GW, ML, MR, NE, SN, TD, TG).
- Published:**
— with international search report

[Continued on next page]

(54) Title: APPARATUSES AND METHODS FOR THERAPEUTICALLY TREATING DAMAGED TISSUES, BONE FRACTURES, OSTEOPENIA, OR OSTEOPOROSIS

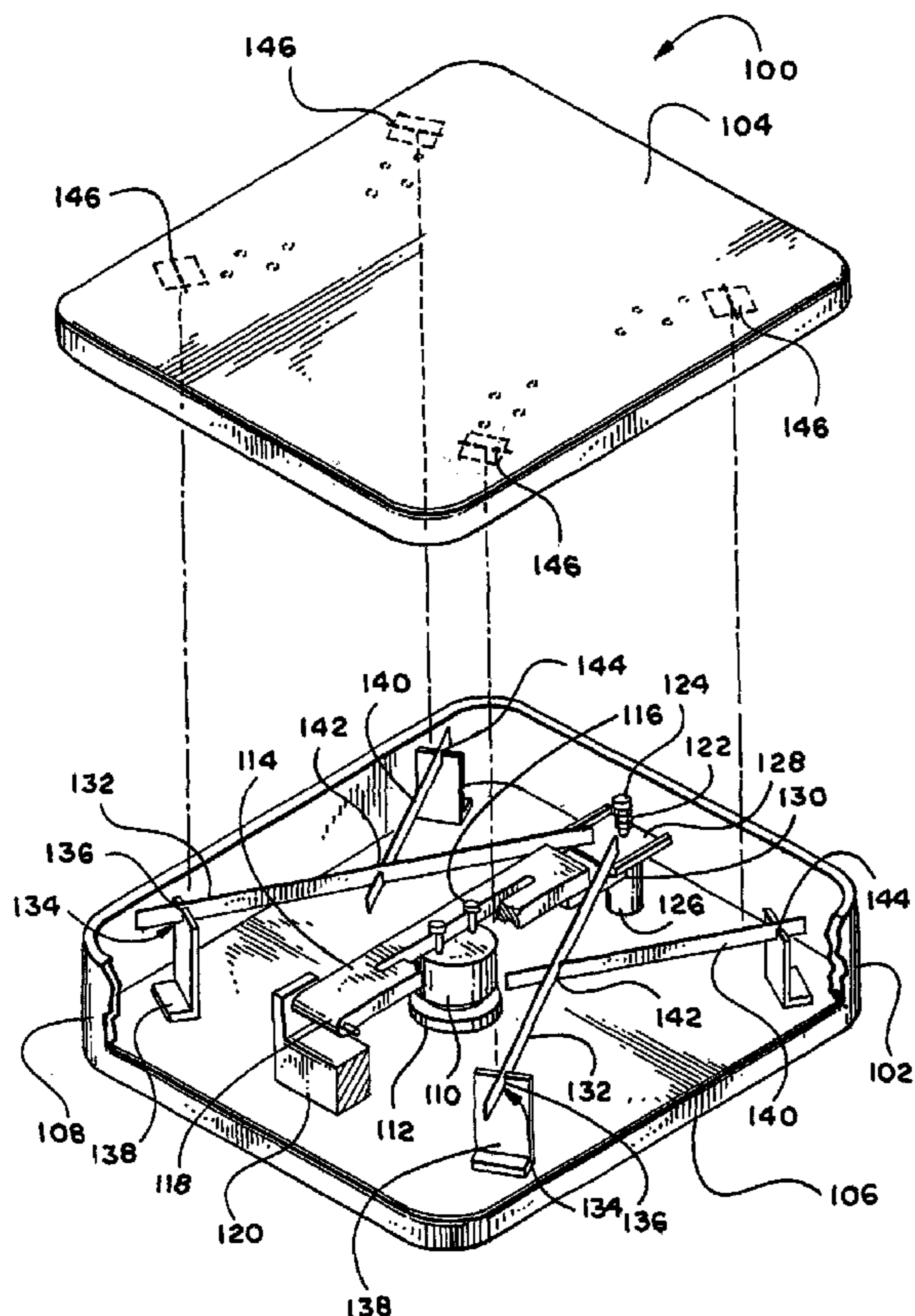

(57) Abstract: Systems and methods for therapeutically treating damaged tissues, bone fractures, osteopenia, or osteoporosis. Systems and methods according to various embodiments of the invention include an oscillating platform for therapeutically treating damaged tissues, bone fractures, osteopenia, osteoporosis, or other tissue conditions in a body. The oscillating platform supports a body. The oscillating platform includes an upper plate; a lower plate; a drive lever supported from the lower plate; a damping member in contact with the drive lever; and a distributing lever arm in contact with the upper plate. The drive lever actuates at a first predetermined frequency. Next, the damping member damps the actuation of the drive lever, creating an oscillating force at a second predetermined frequency. A portion of the oscillating force transfers from the damping member to the distributing lever arm. Then a portion of the oscillating force transfers from the distributing lever arm to the platform so that the body on the platform receives an oscillation at a frequency effective for treatment of damaged tissues, bone fractures, osteopenia, osteoporosis, or other tissue conditions.

WO 2004/043324 A1

WO 2004/043324 A1



— *before the expiration of the time limit for amending the claims and to be republished in the event of receipt of amendments*

For two-letter codes and other abbreviations, refer to the "Guidance Notes on Codes and Abbreviations" appearing at the beginning of each regular issue of the PCT Gazette.

**APPARATUSES AND METHODS FOR THERAPEUTICALLY
TREATING DAMAGED TISSUES, BONE FRACTURES,
OSTEOPENIA, OR OSTEOPOROSIS**

5 BACKGROUND OF THE INVENTION

FIELD OF THE INVENTION

The invention generally relates to the field of stimulating tissue
10 growth and healing, and more particularly to apparatuses and methods
for therapeutically treating damaged tissues, bone fractures,
osteopenia, osteoporosis, or other tissue conditions.

DESCRIPTION OF RELATED ART

15

When damaged, tissues in a human body such as connective
tissues, ligaments, bones, etc. all require time to heal. Some tissues,
such as a bone fracture in a human body, require relatively longer
periods of time to heal. Typically, a fractured bone must be set and
20 then the bone can be stabilized within a cast, splint or similar type of
device. This type of treatment allows the natural healing process to
begin. However, the healing process for a bone fracture in the human
body may take several weeks and may vary depending upon the
location of the bone fracture, the age of the patient, the overall general
25 health of the patient, and other factors that are patient-dependent.
Depending upon the location of the fracture, the area of the bone
fracture or even the patient may have to be immobilized to encourage
complete healing of the bone fracture. Immobilization of the patient
and/or bone fracture may decrease the number of physical activities the
30 patient is able to perform, which may have other adverse health
consequences.

Osteopenia, which is a loss of bone mass, can arise from a decrease in muscle activity, which may occur as the result of a bone fracture, bed rest, fracture immobilization, joint reconstruction, arthritis, and the like. However, this effect can be slowed, stopped, and even
5 reversed by reproducing some of the effects of muscle use on the bone. This typically involves some application or simulation of the effects of mechanical stress on the bone.

Promoting bone growth is also important in treating bone fractures,
10 and in the successful implantation of medical prostheses, such as those commonly known as "artificial" hips, knees, vertebral discs, and the like, where it is desired to promote bony ingrowth into the surface of the prosthesis to stabilize and secure it.

Numerous different techniques have been developed to reduce
15 the loss of bone mass. For example, it has been proposed to treat bone fractures by application of electrical voltage or current signals (e.g., U.S. Patent Nos. 4,105,017; 4,266,532; 4,266,533, or 4,315,503). It has also been proposed to apply magnetic fields to stimulate healing
20 of bone fractures (e.g., U.S. Patent No. 3,890,953). Application of ultrasound to promoting tissue growth has also been disclosed (e.g., U.S. Patent No. 4,530,360).

While many suggested techniques for applying or simulating
25 mechanical loads on bone to promote growth involve the use of low frequency, high magnitude loads to the bone, this has been found to be unnecessary, and possibly also detrimental to bone maintenance. For instance, high impact loading, which is sometimes suggested to achieve a desired high peak strain, can result in fracture, defeating the purpose
30 of the treatment.

It is also known in the art that low level, high frequency stress can be applied to the bone, and that this will result in advantageous promotion of bone growth. One technique for achieving this type of stress is disclosed, e.g., in U.S. Patent Nos. 5,103,806; 5,191,880; 5,273,028; 5,376,065; 5,997,490, and 6,234,975. In this technique, the patient is supported by a platform that can be actuated to oscillate vertically, so that the oscillation of the platform, together with acceleration brought about by the body weight of the patient, provides stress levels in a frequency range sufficient to prevent or reduce bone loss and enhance new bone formation. The peak-to-peak vertical displacement of the platform oscillation may be as little as 2 mm.

However, these systems and associated methods often depend on an arrangement of multiple springs supporting the platform, with the result that precise positioning of the patient on the platform becomes important. Moreover, even a properly positioned patient standing naturally will exert more force on some portions of the platform than others, with the result that obtaining true vertical motion of the patient becomes difficult or impossible.

There remains a need in the art for an oscillating platform apparatus that is highly stable, and relatively insensitive to positioning of the patient on the platform, while providing low displacement, high frequency mechanical loading of bone tissue sufficient to promote healing and/or growth of damaged tissues, bone tissue, reduce or prevent osteopenia or osteoporosis, or other tissue conditions.

Furthermore, there remains a need for apparatuses and methods for therapeutically treating damaged tissues, bone fractures, osteopenia, osteoporosis, or other tissue conditions.

SUMMARY OF THE INVENTION

The invention described herein satisfies the needs described above. More particularly, apparatuses and methods according to various embodiments of the invention are for therapeutically treating damaged tissues, bone fractures, osteopenia, osteoporosis, or other tissue conditions. Furthermore, apparatuses and methods according to various embodiments of the invention can be an oscillating platform apparatus that is highly stable and relatively insensitive to positioning of the patient on the platform, while providing low displacement, high frequency mechanical loading of bone, muscle, tissue, etc. sufficient to promote healing and/or growth of bone tissue, or reduce, reverse, or prevent osteopenia or osteoporosis, or other tissue conditions. Note that a platform according to the invention can be referred to as an “oscillating platform” or as a “mechanical stress platform.”

One aspect of apparatuses and methods according to various embodiments of the invention focuses on a platform for therapeutically treating bone fractures, osteopenia, osteoporosis, or other tissue conditions. The platform supports a body. The platform includes an upper plate; a lower plate; a drive lever supported from the lower plate; a spring in contact with the drive lever; and a distributing lever arm in contact with the upper plate. The drive lever is actuated at a first predetermined frequency. Next, the damping member creates an oscillating force at a second predetermined frequency on the drive lever. A portion of the oscillating force transfers to the distributing lever arm. Then a portion of the oscillating force from the distributing lever arm transfers to the platform so that the body on the platform receives an oscillation.

30

A particular method for therapeutically treating a tissue in a body having a mass includes supporting a body with a platform. The method

includes actuating the platform at a first frequency, and then oscillating the platform to create an oscillating force with a second frequency associated with a resonance frequency of the mass of the body. Finally, the method includes distributing the oscillating force to the mass
5 of the body on the platform.

Another particular method for therapeutically treating tissue in a body includes supporting a body with a mass on a platform. The platform includes an upper plate; a lower plate; a drive lever supported
10 by the lower plate; a damping member in contact with the drive lever; and a distributing lever arm in contact with the upper plate. The method also includes actuating the drive lever at a first predetermined frequency; oscillating the damping member to create an oscillating force with a second predetermined frequency; transferring a portion of the
15 oscillating force from the damping member to the distributing lever arm; and distributing a portion of the oscillating force from the distributing lever arm to the platform so that the body's mass on the platform receives an oscillation.

20 There is provided an apparatus for therapeutically treating a tissue in a body; the apparatus comprising:
a platform configured to support a body, the platform comprising,
an upper plate; and
a lower plate;
25 a drive lever supported from the lower plate;
an actuator configured to actuate the drive lever with respect to the upper plate and lower plate at a first predetermined frequency;
a damping member configured to create an oscillation force at a second predetermined frequency; and
30 a distributing lever arm configured to receive the oscillation force from the spring and to transfer a portion of an oscillation force to the upper plate.

Objects, features and advantages of various apparatuses and methods according to various embodiments of the invention include:

- 5 1. providing the ability to therapeutically treat damaged tissues, bone fractures, osteopenia, osteoporosis, or other tissue conditions in a body;
2. providing the ability to therapeutically treat tissues in a body to reduce or prevent osteopenia or osteoporosis;
- 10 3. providing the ability to therapeutically treat damaged tissues, bone fractures, osteopenia, osteoporosis, or other tissue conditions in a body at a frequency effective to promote tissue or bone healing, growth, and/or regeneration; and
- 15 4. providing an apparatus adapted to therapeutically treat damaged tissues, bone fractures, osteopenia, osteoporosis, or other tissue conditions in a body.

Other objects, features and advantages of various aspects and embodiments of apparatuses and methods according to the invention are apparent from the other parts of this document.

20

BRIEF DESCRIPTION OF THE DRAWINGS

FIG. 1 is a top plan view of an oscillating platform according to various embodiments of the invention, viewed through the top plate, and showing the internal mechanism of the platform.

25

FIG. 2 is a side sectional view taken along line 1-1 in FIG. 1, and partially cut away to show details of the connection of the oscillating actuator to the drive lever.

30

FIG. 3 is an exploded perspective view of the oscillating platform shown in FIG. 1, and partially cut away to show the internal mechanism of the platform.

5 FIG. 4 is a top plan view of another oscillating platform according to various embodiments of the invention, viewed through the top plate, and showing the internal mechanism of the platform.

10 FIG. 5 is a side sectional view along line A-A in FIG. 4, showing the oscillating platform in an up-position.

FIG. 6 is a side sectional view along line A-A in FIG. 4, showing the oscillating platform in a mid-position.

15 FIG. 7 is a side sectional view along line A-A in FIG. 4, showing the oscillating platform in a down-position.

FIG. 8 is a side sectional view along line B-B in FIG. 4.

20 FIG. 9 is a side sectional view along line A-A in FIG. 4.

FIG. 10 is a rear section view along line C-C in FIG. 4, showing the oscillating platform.

25 FIG. 11 is a side-sectional view of another oscillating platform according to various embodiments of the invention, showing the internal mechanism of the platform.

30 FIG. 12 is a side-sectional view of another oscillating platform according to various embodiments of the invention, showing the internal mechanism of the platform.

DETAILED DESCRIPTION OF SPECIFIC EMBODIMENTS

Apparatuses and methods in accordance with various
embodiments of the invention are for therapeutically treating tissue
5 damage, bone fractures, osteopenia, osteoporosis, or other tissue
conditions. Furthermore, apparatuses and methods in accordance with
various embodiments of the invention provide an oscillating platform
apparatus that is highly stable, and relatively insensitive to positioning
of the patient on the platform, while providing low displacement, high
10 frequency mechanical loading of bone tissue sufficient to promote
healing and/or growth of tissue damage, bone tissue, or reduce,
reverse, or prevent osteopenia and osteoporosis, and other tissue
conditions.

15 FIGs. 1-3 illustrate an oscillating platform according to various
embodiments of the invention. FIG. 1 shows a top plan view of the
platform **100**, which is housed within a housing **102**. The platform **100**
can also be referred to as an oscillating platform or a mechanical stress
platform. The housing **102** includes an upper plate **104** (best seen in
20 FIGs. 2 and 3), lower plate **106**, and side walls **108**. Note that the
upper plate **104** is generally rectangular or square-shaped, but can
otherwise be geometrically configured for supporting a body in an
upright position on top of the upper plate **104**, or in a position otherwise
relative to the platform **100**. Other configurations or structures can be
25 also used to support a body in an upright position above, or otherwise
relative to the platform. FIG. 1 shows the platform **100** through top
plate **104**, so that the internal mechanism can be illustrated. Oscillating
actuator **110** mounts to lower plate **106** by oscillator mounting plate
112, and connects to drive lever **114** by one or more connectors **116**.

30

Oscillating actuator **110** causes drive lever **114** to rotate a fixed
distance around drive lever pivot point **118** on drive lever mounting

block **120**. The oscillating actuator **110** actuates the drive lever at a first predetermined frequency. The motion of the drive lever **114** around the drive lever pivot point **118** is damped by a damping member such as a spring **122**, best seen in FIGs. 2 and 3. The damping member or spring **122** creates an oscillation force at a second predetermined frequency. One end of spring **122** is connected to spring mounting post **124**, which is supported by mounting block **126**, while the other end of spring **122** is connected to distributing lever support platform **128**. Distributing lever support platform **128** is connected to drive lever **114** by connecting plate **130**. Distributing lever support platform **128** supports primary distributing levers **132**, which rotate about primary distributing lever pivot points **134**, which may be formed by the surface of the primary distributing lever **132** bearing against the end of a notch **136** in a support **138** extending from lower plate **106**. Secondary distributing levers **140** are connected to primary distributing levers **132** by linkages **142**, which may be simply mutually engaging slots. Secondary distributing levers **132** rotate about pivot points **144** in a manner similar to that described above for the primary distributing levers **132**.

Upper plate **104** is supported by a plurality of contact points **146**, which can be adjustably secured to the underside of the upper plate **104**, and which contact the upper surfaces of primary distributing levers **132**, secondary distributing levers **140**, or some combination thereof.

In operation, a patient (not shown) sits or stands on the upper plate **104**, which is in turn supported by a combination of the primary distributing levers **132** and secondary distributing levers **140**. When the apparatus is operating, oscillating actuator **110** moves up and down in a reciprocal motion, causing drive lever **114** to oscillate about its pivot point **118** at a first predetermined frequency. The rigid connection between the drive lever **114** and distributing lever support platform **128** results in this oscillation being damped by the force created or exerted

by the spring **122**, which can desirably be driven at a second predetermined frequency, in some embodiments its resonance frequency and/or harmonic or sub-harmonics of the resonance frequency. The oscillatory displacement is transmitted from the distributing lever support platform **128** to primary distributing levers **132** and thus to secondary distributing levers **140**. One or more of the primary distributing levers **132** and/or secondary distributing levers **140** distribute the motion imparted by the oscillation to the free-floating upper plate **104** by virtue of contact points **146**. The oscillatory displacement is then transmitted to the patient supported by the upper plate **104**, thereby imparting high frequency, low displacement mechanical loads to the patient's tissues, such as the bone structure of the patient supported by the platform **100**.

In this particular embodiment, the oscillating actuator **110** can be a piezoelectric or electromagnetic transducer configured to generate a vibration. Other conventional types of transducers may be suitable for use with the invention. For example, if small ranges of displacements are contemplated, e.g. approximately 0.002 inches (0.05 mm) or less, then a piezoelectric transducer, a motor with a cam, or a hydraulic-driven cylinder can be employed. Alternatively, if relatively larger ranges of displacements are contemplated, then an electromagnetic transducer can be employed. Suitable electromagnetic transducers, such as a cylindrically configured moving coil high performance linear actuator may be obtained from BEI Motion Systems Company, Kimchee Magnetic Division of San Marcos, California. Such a electromagnetic transducer may deliver a linear force, without hysteresis, for coil excitation in the range of 10-100 Hz, and short-stroke action in ranges as low as 0.8 inches (2 mm) or less.

30

Furthermore, the spring **122** can be a conventional type spring configured to resonate at a predetermined frequency, or resonance

frequency. The resonance frequency of the spring can be determined from the equation:

Resonance Frequency (Hz) = [Spring Constant (k) / Mass (lbs)]^{1/2}. For
5 example, if the oscillating platform is to be designed for treatment of humans, the spring **122** can be sized to resonate at a frequency between approximately 30-36 Hz. If the oscillating platform is to be designed for the treatment of animals, the spring **122** can be sized to resonate at a frequency up to 120 Hz. An oscillating platform
10 configured to oscillate at approximately 30-36 Hz utilizes a compression spring with a spring constant (k) of approximately 9 pounds (lbs.) per inch in the embodiment shown. In other configurations of an oscillating platform, oscillations of a similar range and frequency can be generated by one or more springs, or by other devices or mechanisms designed to
15 create or otherwise dampen an oscillation force to a desired range or frequency.

FIG. 2 is a side sectional view taken along line 1-1 in FIG. 1, and partially cut away to show details of the connection of the oscillating
20 actuator **110** to the drive lever **114**. The drive lever **114** includes an elongate slot **148** (also shown in FIGs. 1 and 3) for receiving connectors **116**. The elongate slot **148** permits the oscillating actuator **110** to be selectively positioned along a portion of the length of the drive lever **114**. The connectors **116** can be manually adjusted to position the
25 oscillating actuator with respect to the drive lever **114**, and then readjusted when a desired position for the oscillating actuator **110** is selected along the length of the elongate slot **148**. By adjusting the position of the oscillating actuator **110**, the vertical movement or

displacement of the drive lever **114** can be adjusted. For example, if the oscillating actuator **110** is positioned towards the drive lever pivot point **118**, then the vertical movement or displacement of the drive lever **114** at the opposing end near the spring **122** will be relatively greater than when the oscillating actuator **110** is positioned towards the spring. Conversely, as the oscillating actuator **110** is positioned towards the spring **122**, the vertical movement or displacement of the drive lever **114** at the opposing end near the spring **122** will be relatively less than when the oscillating actuator **110** is positioned towards the drive lever pivot point **118**.

FIG. 3 is an exploded perspective view of the oscillating platform **100** shown in FIG. 1, and partially cut away to show the internal mechanism of the platform **100**. In this embodiment as well as other embodiments, the invention is contained within a housing **102**. The housing **102** can be made from any material sufficiently strong for the purposes described herein, e.g. any material that can bear the weight of a patient on the upper plate. For example, suitable materials can be metals, e.g. steel, aluminium, iron, etc.; plastics, e.g. polycarbonates, polyvinylchloride, acrylics, polyolefins, etc.; or composites; or combinations of any of these materials.

Also shown in this embodiment is a series of holes **150** machined through the upper plate **104** of the platform **100**. The holes **150** are arranged parallel with each of the primary distributing levers **132** and secondary distributing levers **140**. These holes **150** (also shown in FIG. 1) provide different points of connection or attachment for contact points **146**, thereby varying the points at which these contact points contact the distributing levers **132**, **140**, and thus the amount of lever arm and mechanical advantage used in driving the upper plate **104** to vibrate.

FIGs. 4-10 illustrate another oscillating platform according to various embodiments of the invention. FIG. 4 shows a top plan view of the platform 400, which is housed within a housing 402. The platform 400 can also be referred to as an "oscillating platform" or a "mechanical stress platform." The housing 402 includes an upper plate 404 (best seen in FIGs. 5-9), lower plate 406, and side walls 408. Note that the upper plate 404 is generally rectangular or square-shaped, but can otherwise be geometrically configured for supporting a body in an upright position on top of the upper plate 404, or in a position otherwise relative to the platform. Other configurations or structures can be also used to support a body in an upright position above, or otherwise relative to the platform. FIG. 4 shows the platform 400 through upper plate 404, so that the internal mechanism can be illustrated. An oscillating actuator 410 mounts to lower plate 406. The oscillating actuator 410 is an electromagnetic-type actuator that consists of a stationary coil 412 and armature 414. The oscillating actuator 410 is configured so that when the stationary coil 412 is energized, the armature 414 can be actuated relative to the stationary coil 412. The stationary coil 412 mounts to the lower plate 406, while the armature 414 connects to a drive lever 416 by one or more connectors 418.

Oscillating actuator 410 causes drive lever 416 to rotate a fixed distance around drive lever pivot point 420 on drive lever mounting block 422. The oscillating actuator actuates the drive lever 416 at a first predetermined frequency. The drive lever mounting block mounts to the lower plate 406. The motion of the drive lever 416 around the drive lever pivot point 420 is damped by a damping member such as a spring 424, best seen in FIGs. 5-8. The damping member or spring 424 creates an oscillation force at a second predetermined frequency, such as its resonance frequency or a harmonic or sub-harmonic of the resonance frequency. The spring 424 fits around a damping member mounting post such as a spring mounting post 426 which extends

between a damping member mounting block such as a spring mounting block **428** and the upper plate **404**. The spring mounting post **426** mounts to the lower plate **406**.

5 A hole **430** near one end of the drive lever **416** permits the spring mounting post **426** to extend upward from the spring mounting block **428**, through the drive lever **416**, and to the bottom side of the top plate **404**. One end of the spring **424** is connected to a spring mounting block **428** while the other end of the spring **424** is connected to a lever
10 bearing surface **432** which mounts to the bottom side of the drive lever **416** and around the hole **430** through the drive lever **416**. Lever bearing surface **430** is connected to drive lever **416** by a threaded connector **434** that fits within the hole **430**. Thus the spring **424** extends between the bottom side of the drive lever **416** and the spring
15 mounting block **428**.

A crossover bar **436** mounts to the bottom side of the drive lever **416** with connector **438**, and extends in a direction substantially perpendicular to the length of the drive lever **416**. At each end of the
20 crossover bar **436**, side distributing levers **440** mount to the crossover bar **436** with connectors **442** at one end of each side distributing lever **440**. Each side distributing lever **440** then extends substantially perpendicular from the length of the crossover bar **436** and substantially parallel to a respective sidewall **408** of the platform **400**. Each side
25 distributing lever **440** rotates about side distributing lever pivot points **444** located near the opposing ends of the side distributing levers **440**. A lift pin **446** adjacent to the side distributing lever pivot point **444** and extending substantially perpendicular from the side distributing lever arm **440** bears against the end of a notch **448** in a support **450**
30 extending from upper plate **404**.

Upper plate **404** is supported by a plurality of contact points **452** which result from the bearing contact between the upper surface of the lift pin **446** and a portion of the notch **448** in the support **450**.

5 A printed circuit board (PCB) **454** mounts to the lower plate **406** by connectors **456**. The PCB **454** provides control circuitry and associated executable commands or instructions for operating the oscillating actuator **410**.

10 An access panel **458** in the upper plate **404** provides maintenance access to the internal mechanism of the platform **400**.

In operation, a patient (not shown) sits or stands on the upper plate **404**, which is in turn supported by the lift pins **446**. When the apparatus is operating, oscillating actuator **410** moves up and down in a reciprocal motion, causing drive lever **416** to oscillate about its pivot point **420** at a first predetermined frequency. The rigid connection between the drive lever **416** and drive lever mounting block **422** results in this oscillation being damped by the force exerted by the spring **424**, which can be driven at a second predetermined frequency, in some embodiments its resonance frequency, or a harmonic or sub-harmonic of the resonance frequency. The damped oscillatory displacement is transmitted from the drive lever **416** to crossover bar **436** and thus to side distributing lever arms **440**. One or more of the side distributing lever arms **440** distribute the motion imparted by the oscillation to the free-floating upper plate **404** by virtue of the lift pins **446** and contact points **452**. The oscillatory displacement is then transmitted to the patient supported by the upper plate **404**, thereby imparting high frequency, low displacement mechanical loads to the patient's tissues, such as a bone structure of the patient supported by the platform **400**.

15
20
25
30

It is desired that a high frequency, low displacement mechanical load be imparted to the bone structure of the patient supported by the platform. To achieve this load, in some embodiments the horizontal centerline distance between the damping member or spring **424** and the drive lever pivot point **420** is approximately 12 inches (304.8 mm); and the horizontal centerline distance between the oscillating actuator **410** and the drive lever pivot point **420** is approximately 3 inches (76.2 mm). The ratio of the distance from the damping member or spring **424** to the drive lever pivot point **420**, and from the oscillating actuator **410** to the drive lever pivot point **420** may be about 4 to 1, and is also called the drive ratio. Furthermore, in this embodiment, the horizontal centerline distance between the side distributing lever pivot point **444** near the drive lever pivot point **420** and the side distributing lever pivot point **444** near the damping member or spring **424** should be approximately 12 inches (304.8 mm); and the horizontal centerline distance between each side distributing lever pivot point **444** and the respective lift pin may be approximately 3/4 inch (19 mm). The ratio of the distance from the side distributing lever pivot point **444** near the drive lever pivot point **420** to the side distributing lever pivot point **444** near the spring **424**, and from each side distributing lever pivot point **444** and the respective lift pin is about 16 to 1 in some embodiments, and is also called the lifting ratio. In the configuration shown and described, the oscillating platform **400** provides a specific drive ratio and lifting ratio. Other combinations of drive ratios and lifting ratios may be used with varying results in accordance with various embodiments of the invention.

Moreover, in this particular embodiment, the oscillating actuator **410** is an electromagnetic-type actuator configured to actuate or generate a vibration, such as a combination coil and armature or a solenoid. Other conventional types of actuators may be suitable for use with the invention. In the configuration shown and described, the

oscillating actuator may be configured to actuate at approximately 30-36 Hz.

Furthermore, the damping member or spring **424** can be a
5 conventional type coil spring configured to resonate in a range of
predetermined frequencies. For example, if the oscillating platform is to
be designed for treatment of humans, the damping member or spring is
sized to resonate at a frequency between approximately 30 and 36 Hz.
If the oscillating platform is to be designed for the treatment of vertebrae
10 animals, the damping member or spring is sized to resonate at a
frequency range between approximately 30 Hz and 120 Hz. In the
configuration shown, the damping member or spring is a compression
spring with a spring constant of approximately 9 pounds (lbs.) per inch.
In other configurations of an oscillating platform, oscillations of a similar
15 range and frequency can be generated by one or more damping
members or springs, or by other devices or mechanisms designed to
create or otherwise dampen an oscillation force to a desired range or
frequency.

20 FIGs. 5-7 illustrate the platform **400** of FIG. 4 in operation. FIG. 5
is a side sectional view along line A-A in FIG. 4, showing the platform
400 in an up-position. FIG. 6 is a side sectional view along line A-A in
FIG. 4, showing the platform **400** in a mid-position. FIG. 7 is a side
sectional view along line A-A in FIG. 4, showing the platform **400** in a
25 down-position. In FIGs. 5-7, the internal mechanism of the platform **400**
is shown in operation with respect to a load (not shown) placed on the
upper plate **404**. These views illustrate the relative positions of the
drive lever **416**, side distribution lever arms **440**, and the spring **424**
while various loads are placed on the upper plate **404**.

30

As shown in FIGs. 5-7, when a specific load is placed on the upper
plate **404**, the side distributing lever arms **440** respond to the respective

load on the upper plate **404**. In all instances, the load creates a downward force on the upper plate **404** that is transferred from the supports **450** to a respective lift pin **446** and further transferred to the side distributing lever arms **440**, the crossover bar **436**, and then to the drive lever **416** and spring **424**. For example, in FIG. 5, when a load weighing approximately fifty pounds (22.5 kilograms) is placed on the upper plate **404**, a side distributing lever arm **440** nearest to and adjacent to the drive lever pivot point **420** is displaced upward towards the crossover bar **436**, whereas the side distributing lever arm **440** nearest to and adjacent to the spring **424** is displaced downward from the crossover bar **436**. The drive lever **416** is displaced generally upward from the drive lever pivot point **420** with the spring **424** in a relatively extended position.

In FIG. 6, when a load weighing approximately 140 pounds (63 kilograms) is placed on the upper plate **404**, the side distributing lever arm **440** nearest to and adjacent to the drive lever pivot point **420** is displaced to a substantially parallel orientation with the front side distributing lever arm **440** nearest to and adjacent to the spring **424**. The drive lever **416** is displaced generally horizontal from the drive lever pivot point **420** with the spring **424** in a relatively compressed position compared to FIG. 5.

Finally, in FIG. 7, when a relatively large load of approximately 300 pounds (135 kilograms) is placed on the upper plate **404**, the side distributing lever arm **440** nearest to and adjacent to the drive lever pivot point **420** is displaced downward towards the crossover bar **436**, whereas the side distributing lever arm **440** nearest to and adjacent to the spring **424** is displaced upward from the crossover bar **436**. The drive lever **416** is displaced generally downward from the drive lever pivot point **420** with the spring **424** in a relatively compressed position compared to FIGs. 5 and 6.

FIG. 8 is a side sectional view of the platform **400** along line B-B in FIG. 4. This view illustrates the platform **400** in a no-load position, and details the relative positions of the upper plate **404**, side distribution lever arms **440**, and crossover bar **436** in a no-load position.

FIG. 9 is a side sectional view of the platform **400** along line A-A in FIG. 4. This view further illustrates the platform **400** in a no-load position, and details the relative positions of the drive lever **416**, crossover bar **436**, spring **424**, and oscillating actuator **410** in a no load position.

FIG. 10 is a rear section view of the platform **400** along line C-C in FIG. 4, showing the platform **400** in a no-load position, and details the relative positions of the drive lever **416**, oscillating actuator **410**, crossover bar **436**, side distribution lever arms **440**, and upper plate **404**.

FIG. 11 illustrates another oscillating platform **1100** according to various embodiments of the invention. In FIG. 11, a cross-sectional view of the internal mechanism of an oscillating platform **1100**. This embodiment is shown with a housing **1102** including an upper plate **1104**, lower plate **1106**, and side walls **1108**. Note that the upper plate **1104** is generally rectangular or square-shaped, but can otherwise be geometrically configured for supporting a body in an upright position on top of the upper plate **1104**, or in a position otherwise relative to the platform. Other configurations or structures can be also used to support a body in an upright position above, or otherwise relative to the platform. Oscillating actuator **1110** mounts to lower plate **1106** by oscillator mounting plate **1112**, and connects to drive lever **1114** by one or more connectors (not shown).

Oscillating actuator **1110** causes drive lever **1114** to rotate a fixed distance at a first predetermined frequency around drive lever pivot point **1116** on drive lever mounting block **1118**. The motion of the drive lever **1114** around the drive lever pivot point **1116** is damped by a damping member such as a cantilever spring **1120**. The cantilever spring **1120** then creates an oscillation force at a second predetermined frequency, such as its resonance frequency or a harmonic or sub-harmonic of the resonance frequency. One end of the cantilever spring mounts to a spring mounting block **1122**, while the other end of cantilever spring **1120** is in contact with the drive lever **1114** or spring contact point **1124**. The spring contact point **1124** may be an extension piece mounted to the underside of the drive lever **1114** and configured for contact with the cantilever spring **1120**.

One or more lift pins **1126** extend from a lateral side of the drive lever **1114**. The lift pins **1126** engage a respective notch **1128** in one or more corresponding supports **1130** mounted to the underside of the upper plate **1104**. The free-floating upper plate **1104** is supported by one or more contact points **1132** between the lift pins **1126** and the supports **1130**.

The second predetermined frequency, such as the resonance frequency or a harmonic or sub-harmonic of the resonance frequency, of the cantilever spring **1120** can be adjusted by a node point **1134**. The node point **1134** consists of a dual set of rollers **1136**, a roller mounting block **1138**, connectors **1140** and an external knob **1142**. The cantilever spring **1120** mounts between the dual set of rollers **1136** so that the rollers **1136** can be positioned along the length of the cantilever spring **1120**. The dual set of rollers **1136** mount to the roller mounting block **1138** via connectors **1140**. The position of the roller mounting block **1138** can be adjusted along the length of the cantilever spring

1120 by an external knob **1142** that slides along a track **1144** parallel with the length of the cantilever spring **1120**.

5 The position of the node point **1134** can be manually or automatically adjusted, or otherwise pre-set along the length of the cantilever spring **1120**. When the node point **1134** is adjusted to a specific position along the cantilever spring **1120**, the node point **1120** acts as a fixed point or fulcrum for the cantilever spring **1120** so that a resonant length of the cantilever spring **1120** can be set to a specific amount. Note that the resonant length of the cantilever spring **1120** depends upon the mass of the load placed on the upper plate **1104** and the mass of the combined drive lever **1114** and cantilever spring **1120**. The end of the cantilever spring **1120** in contact with the drive lever **1114** or spring contact point **1124** can then resonate when the oscillating actuator **1110** is activated. For example, with a fixed mass placed on the upper plate **1104**, as the node point **1134** is positioned towards the drive lever **1114** or spring contact point **1124**, the resonant length of the cantilever spring **1120** becomes relatively lesser. Alternatively, as the node point **1134** is positioned towards the spring mounting block **1122**, the resonant length of the cantilever spring **1120** becomes relatively greater.

15 FIG. 12 is a side-sectional view of another oscillating platform **1200** according to various embodiments of the invention, showing the internal mechanism of the platform. The view of this embodiment details another configuration of the internal mechanism of the oscillating platform **1200** with a cantilever spring with a sliding node. Other configurations or structures can be also used to perform the disclosed functions of the oscillating platform.

30

Generally, a housing (not shown) houses the internal mechanism. The housing includes a lower plate **1202** or base. An upper plate (not

shown) for supporting a body or a mass opposes the lower plate **1202**. An oscillating actuator (not shown), such as those disclosed in previous embodiments, mounts to lower plate **1202**, and contacts the drive lever **1204** in a manner similar to that shown in FIG. 11. Generally, the drive lever **1204** is positioned adjacent to the upper plate to transfer oscillation movement from the drive lever to the upper plate and then to a body supported by or in contact with the upper plate.

A node mounting block **1206** and an associated servo stepper motor **1208** mount to the lower plate **1202**. The node mounting block **1206** and servo stepper motor **1208** connect to each other via a connector **1210**. When adjusted, the node mounting block **1206** can move with respect to the lower plate **1202** via a slot **1212** machined in the lower plate **1202**. The node mounting block **1206** includes a first roller **1214** mounted to and extending from the upper portion of the node mounting block **1206**.

A damping member such as a cantilever spring **1216** mounts to the lower plate **1202** with a fixed mounting **1218**. The cantilever spring **1216** extends from the fixed mounting **1218** towards the proximity of the node mounting block **1206**. The first roller **1214** mounted to the node mounting block **1206** contacts a lower portion of the extended cantilever spring **1216**. As the node mounting block **1206** is moved within the slot **1212**, the first roller **1214** moves with respect to the cantilever spring **1216**. Similar to the configuration shown in FIG. 11, this type of configuration is called a "sliding node." A sliding node-type configuration causes the damping member such as a cantilever spring **1216** to change its frequency response as the node mounting block **1206** changes its position with respect to the damping member such as the cantilever spring **1216**.

As described above, the drive lever **1204** mounts to or contacts the lower portion of the upper plate. A roller mount **1220** extends from the lower portion of the drive lever **1204** towards the cantilever spring **1216**. A second roller **1222** mounts to the roller mount **1220**, and
5 contacts an upper portion of the extended cantilever spring **1216**.

In this configuration, the oscillating actuator (not shown) causes drive lever **1204** to rotate a fixed distance at a first predetermined frequency around a drive lever pivot point (not shown). The motion of
10 the drive lever **1204** around the drive lever pivot point is damped by a damping member such as the cantilever spring **1216**. The cantilever spring **1216** then creates an oscillation force at a second predetermined frequency, such as its resonance frequency or a harmonic or sub-harmonic of the resonance frequency.

15

The second predetermined frequency, such as the resonance frequency or a harmonic or sub-harmonic of the resonance frequency, of the cantilever spring **1216** can be adjusted as the position of the node mounting block **1206** is changed with respect to the cantilever
20 spring, i.e. sliding node configuration. The position of the node mounting block **1206** can be manually or automatically adjusted, or otherwise pre-set along the length of the damped member or cantilever spring **1216**. Note that the resonant length of the damped member such as the cantilever spring **1216** depends upon the mass of the load
25 placed on the upper plate and the mass of the combined drive lever **1204** and cantilever spring **1216**. The end of the cantilever spring **1216** in contact with the drive lever **1204** or a spring contact point can then resonate when the oscillating actuator is activated.

30

In the embodiments of an oscillating platform shown in FIGs. 11 and 12, and in other structures in accordance with various embodiments of the invention, the platform (also referred to as an

“oscillating platform” or “mechanical stress platform”) may be configured to allow different users to selectively adjust the platform to compensate for different weights of each user. For example, in a physical rehabilitation environment, patients or users having different weights
5 may want to utilize the same oscillating platform. Each patient or user could set-up the oscillating platform for an anticipated user weight on the upper plate so that the oscillating platform can apply an oscillation force of a desired resonance frequency or harmonic or sub-harmonic of the resonance frequency to the user when he or she sits or stands on
10 the upper plate. An external knob may be provided on the oscillating platform to permit the user to selectively adjust the oscillating platform in accordance with the user’s weight.

In some embodiments such as those shown in FIGs. 11 and 12,
15 the external knob controls the position of the sliding node, effectively changing the resonant length of the damped member such as a cantilever spring. In other embodiments, the external knob would control the position of the oscillating actuator relative to the drive lever. This type of configuration would allow the user to adjust the “effective
20 length” of the drive lever and increase or decrease the vertical displacement of the drive lever as needed. The “effective length” of the drive lever is the distance from the centerline of the oscillating actuator to the end of the drive lever nearest the damping member or spring. For example, a user may increase the “effective length” of the drive
25 lever by positioning the oscillating actuator towards the drive lever pivot point so that the corresponding vertical displacement of the drive lever can be increased. Conversely, a user may decrease the “effective length” of the drive lever by positioning the oscillating actuator towards the damping member or spring so that the corresponding vertical
30 displacement of the drive lever can be decreased.

Thus, by positioning the oscillating actuator to a predetermined position in accordance with the weight of the user, or by positioning the sliding node in accordance with the weight of the user, the oscillating platform can provide a therapeutic vibration within a specific resonance
5 frequency, or harmonic or sub-harmonic of the resonance frequency, range that is optimal for stimulating tissue or bone growth for different users having a range of different weights.

In other embodiments of the invention, the oscillating actuator may
10 be configured for a single position. For example, in a home environment, a single patient only may utilize the oscillating platform. To reduce the amount of time necessary to set-up and operate the oscillating platform, the oscillating actuator may have a pre-set position in accordance with the particular patient's weight. The patient can then
15 utilize the oscillating platform without need for adjusting the position of the oscillating actuator.

Finally, the embodiments disclosed above can also be adapted with a "self-tuning" feature. For example, when a user steps onto an
20 oscillating platform with a self-tuning feature, the user's mass may be first determined. Based upon the mass of the user, the oscillating platform automatically adjusts the various components of the oscillating platform so that the oscillating platform can apply an oscillation force of a desired resonance frequency or harmonic or sub-harmonic of the
25 resonance frequency to the user when he or she sits or stands or is otherwise supported by the oscillating platform. In this manner, the oscillating platform can provide a therapeutic treatment in accordance with the various embodiments of the invention, without need for manually adjusting the oscillating platform according to the user's mass,
30 and reducing the possibility of user error in adjusting or manually tuning the oscillating platform for the desired treatment frequency.

While the above description contains many specifics, these specifics should not be construed as limitations on the scope of the invention, but merely as exemplifications of the disclosed embodiments. Those skilled in the art will envision many other possible variations that
5 within the scope of the invention as defined by the claims appended hereto.

CLAIMS

1. A method for oscillating a platform comprising the steps of:
supporting an object with a mass on a platform, the platform comprising:
 - an upper plate;
 - a lower plate;
 - a drive lever supported by the lower plate;
 - a damping member in contact with the drive lever; and
 - a distributing lever arm in contact with the upper plate;actuating the drive lever at a first predetermined frequency including activating an oscillating actuator to create a vertical displacement of the drive lever;
oscillating the damping member to create an oscillating force with a second predetermined frequency;
transferring a portion of the oscillating force from the damping member to the distributing lever arm; and
distributing a portion of the oscillating force from the distributing lever arm to the platform so that the object's mass on the platform receives an oscillation.
2. The method of claim 1, wherein the oscillating actuator consists of at least one of the following:
 - an electromagnetic transducer, a piezoelectric transducer, or an electromagnetic coil and armature.
3. The method of claims 1 or 2, wherein the damping member is a coil spring.
4. The method of any of claims 1 to 3, wherein the damping member is a cantilever spring with at least one end mounted to the lower plate.
5. The method of any of claims 1 to 4, wherein the second predetermined frequency is between 30 and 36 Hz.

6. The method of any of claims 1 to 4, wherein the second predetermined frequency is between 30 and 120 Hz.
7. The method of any of claims 1 to 6, further comprising the step of:
biasing the drive lever to compensate for a weight of the object.
8. The method of claim 7, wherein the biasing the drive lever to compensate for a weight of the object, comprises:
shortening an effective length of the drive lever when a relatively heavy weight is placed on the upper plate; and
increasing the effective length of the drive lever when a relatively light weight is placed on the upper plate.
9. The method of any of claims 1 to 8, further comprising the step of:
biasing a resonance length of the damping member.
10. An apparatus for therapeutically treating tissue in a body, the apparatus comprising:
a platform configured to support a body, the platform comprising:
an upper plate; and
a lower plate;
a drive lever supported from the lower plate;
a drive lever mounting block mounted to the lower plate and configured to support one end of the drive lever;
a drive lever pivot point, wherein the drive lever is configured to rotate about an axis with respect to the drive lever mounting block;
an actuator configured to actuate the drive lever with respect to the upper plate and lower plate at a first predetermined frequency;
a damping member configured to create an oscillation force at a second predetermined frequency;
a damping member mounting block mounted to the lower plate;

a damping member post mounted to the damping member mounting block, and configured to concentrically receive the damping member;

a distributing lever support platform mounted to an end of the drive lever, wherein one end of the damping member mounts to the damping member post and the opposing end of the damping member mounts to the damping member platform so that when the drive lever actuates, the damping member damps the drive lever actuation; and

a distributing lever arm configured to receive the oscillation force from the damping member and to transfer a portion of an oscillation force to the upper plate.

11. The apparatus of claim 10, wherein the actuator comprises:

a coil mounted to the lower plate and configured to be electrically energized; and
an armature mounted to the drive lever and configured to be actuated by an electrically energized coil.

12. The apparatus of claim 10, wherein the actuator comprises a transducer mounted between the lower plate and the drive lever, wherein the transducer is configured to actuate the drive lever.

13. The apparatus of any of claims 10 to 12, wherein the distributing lever arm comprises:

a primary distributing lever arm in contact with the upper plate and mounted to the lower plate while extending to a damper spring platform, wherein the primary distributing lever arm can receive a portion of the oscillation force transferred from the damping spring platform; and

wherein the primary distributing lever arm is in substantial bearing contact with the upper plate so that a portion of the oscillation force is transferred from the primary distributing lever arm to the upper plate.

14. The apparatus of claim 13, further comprising:

a secondary distributing lever arm in contact with the upper plate and mounted to

the lower plate while extending to a portion of the primary distributing lever arm, wherein the secondary distributing lever arm can receive the oscillation transferred from the primary distributing lever arm; and

wherein the secondary distribution lever arm is in bearing contact with the primary distributing lever arm so that the oscillation is further transferred to the upper plate.

15. The apparatus of any of claims 10 to 14, wherein the second predetermined frequency is between 30 and 36 Hz for a person's body supported on the upper plate.

16. The apparatus of any of claims 10 to 14, wherein the second predetermined frequency is between 30-120 Hz for an animal's body supported on the upper plate.

17. The apparatus of any of claims 10 to 16, wherein the damping member has a spring constant of 9 pounds per inch.

18. The apparatus of any of claims 10 to 17, wherein a ratio of a distance from the damping member from the drive lever pivot point and a distance from the actuator to drive lever pivot point is 4 to 1, and a ratio of a distance from the distributing lever pivot point to the drive lever pivot point and a distance from a lift pin to the drive lever pivot point is 16 to 1.

19. An apparatus for therapeutically treating tissue in a body, the apparatus comprising:

a platform configured to support a body, the platform comprising:

an upper plate;

and a lower plate;

a drive lever supported from the lower plate;

an actuator configured to actuate the drive lever with respect to the upper plate and lower plate at a first predetermined frequency;

a damping member configured to create an oscillation force at a second predetermined frequency; and

a distributing lever arm configured to receive the oscillation force from the damping member and to transfer a portion of an oscillation force to the upper plate, the distributing lever arm comprising:

a support mounted to the upper plate;

a crossover bar mounted to the drive lever and configured to transfer a portion of the oscillation force to the distributing lever arm; and

wherein the distributing lever arm receives a portion of the oscillation force transferred from the crossover bar, and the distributing lever arm transfers a portion of the oscillation force to the support.

20. The apparatus of claim 19, wherein the distributing lever arm is a side distributing lever arm.

21. The apparatus of claim 20, further comprising:

a plurality of supports mounted to the upper plate; and

a corresponding plurality of side distributing lever arms that receive a portion of the oscillation force transferred from the crossover bar, wherein each respective side distributing arm transfers a portion of the oscillation force to a respective support.

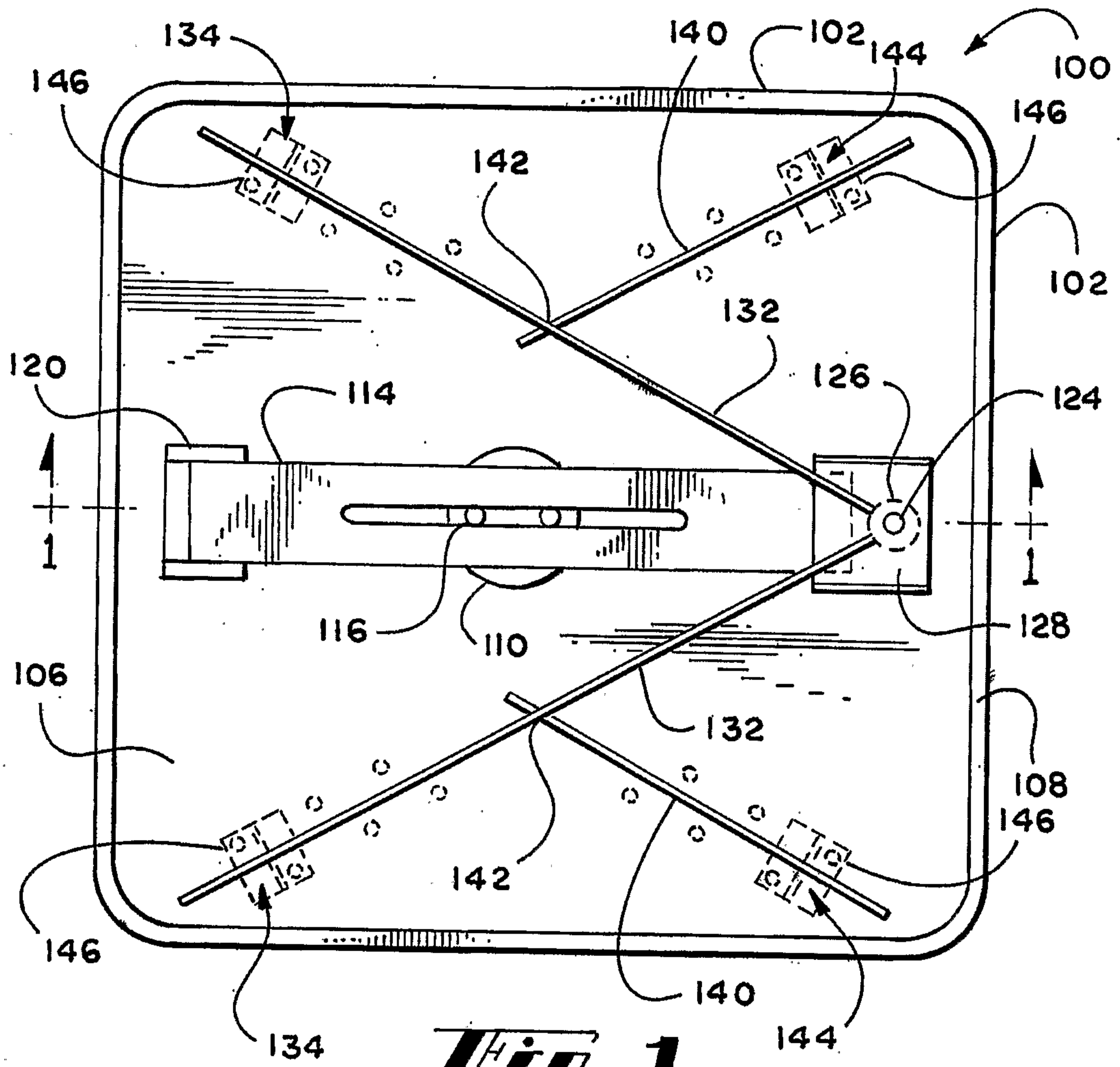

Fig. 1

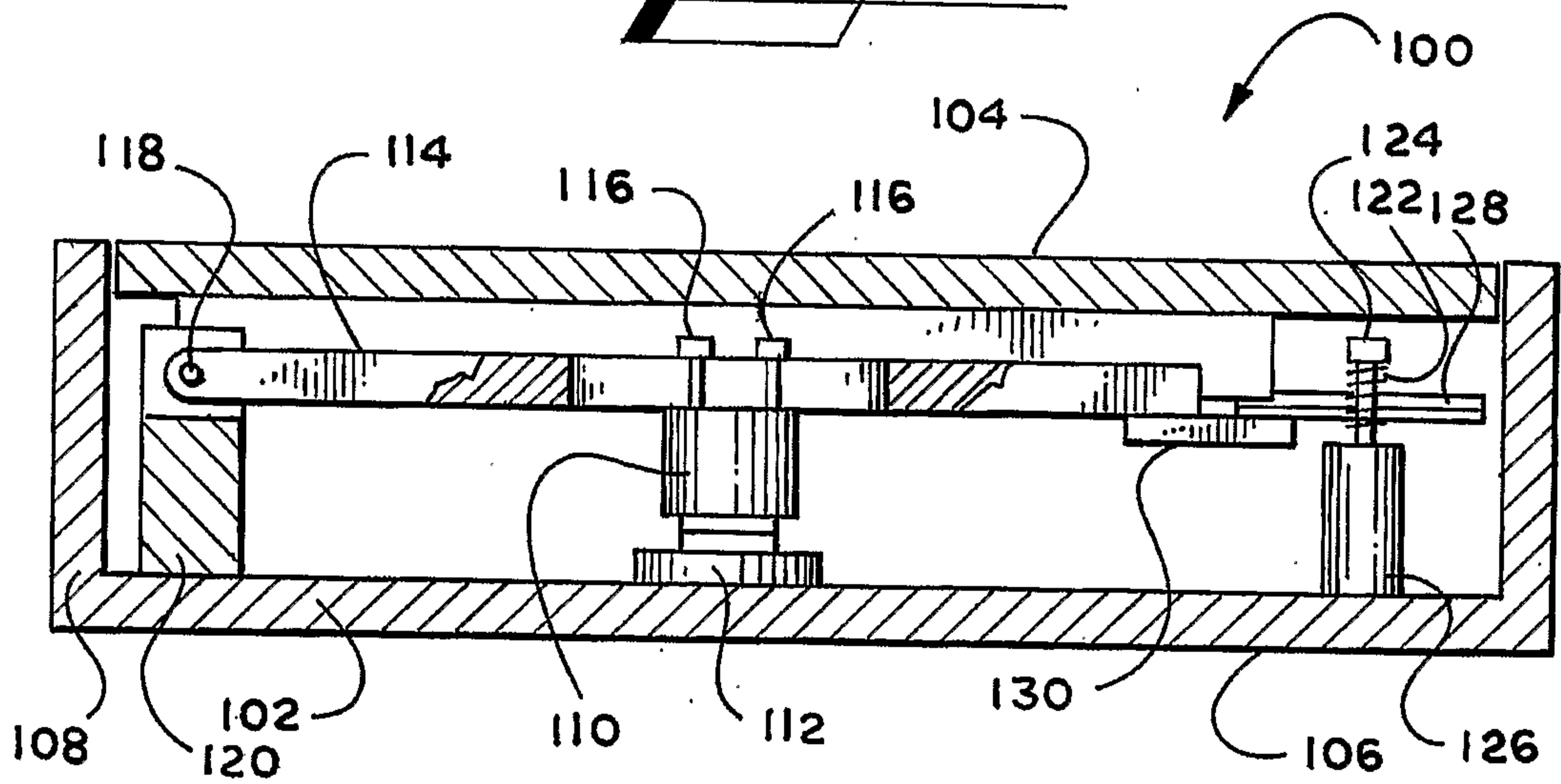

Fig. 2

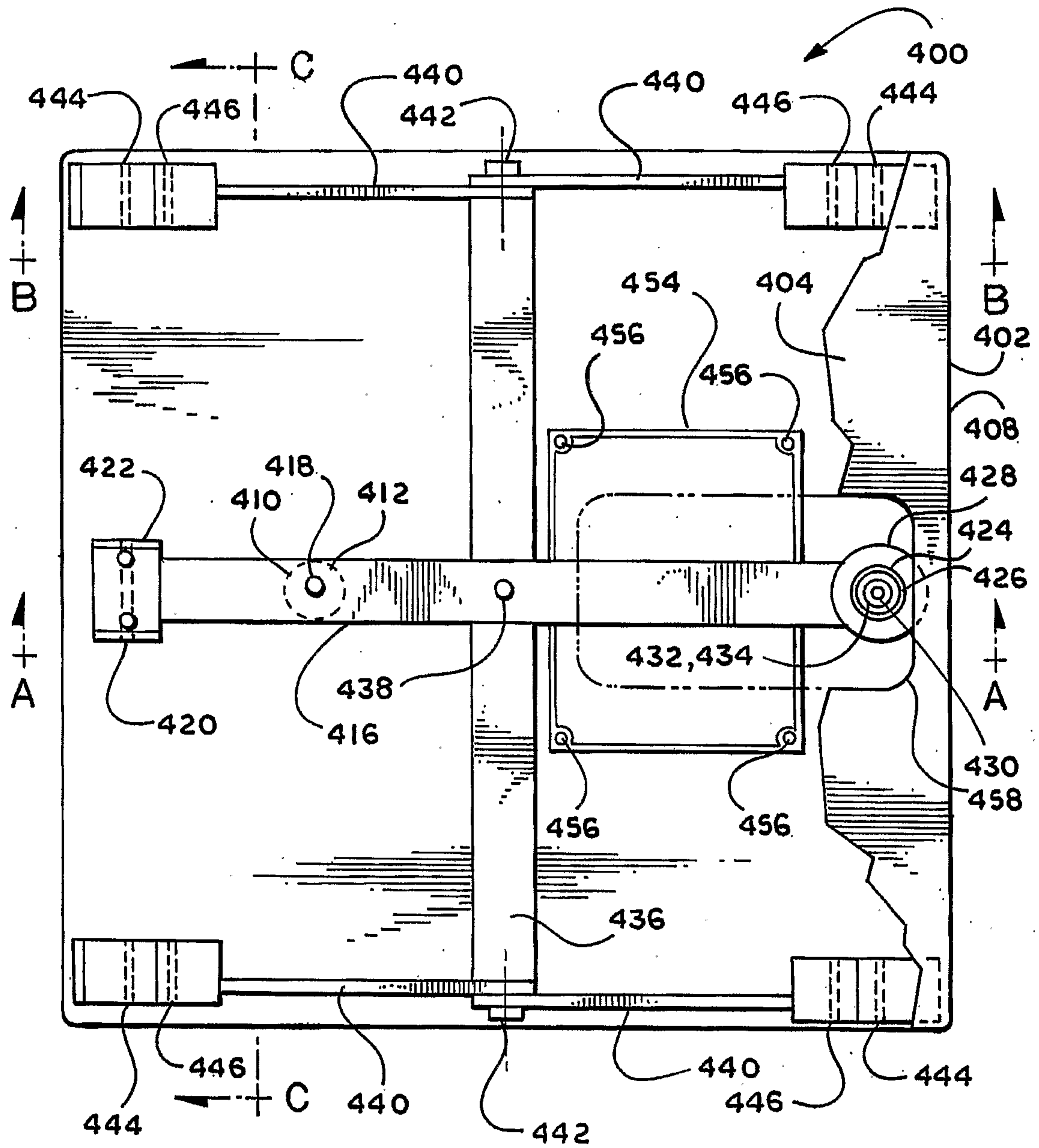
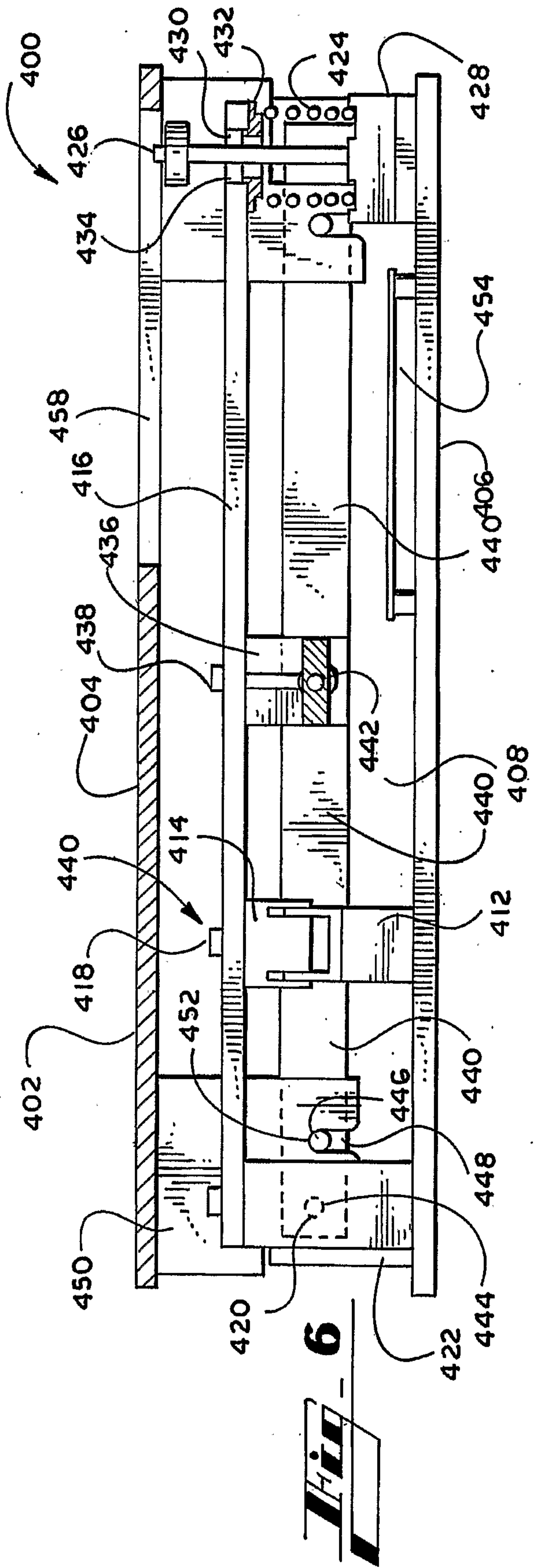
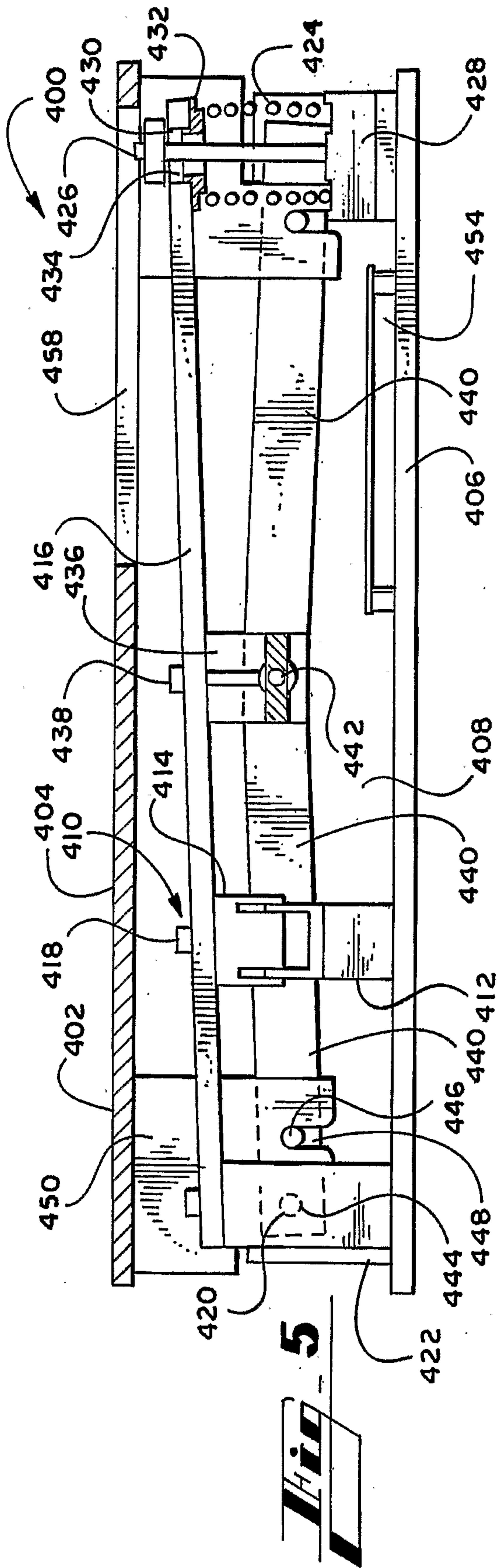
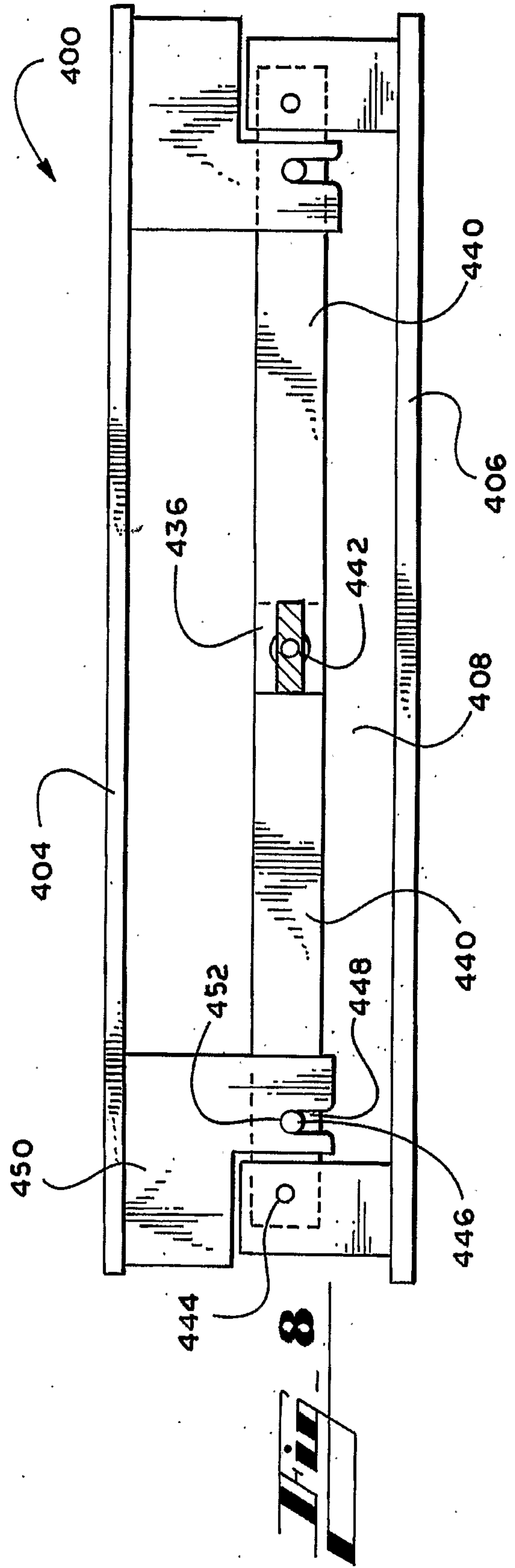
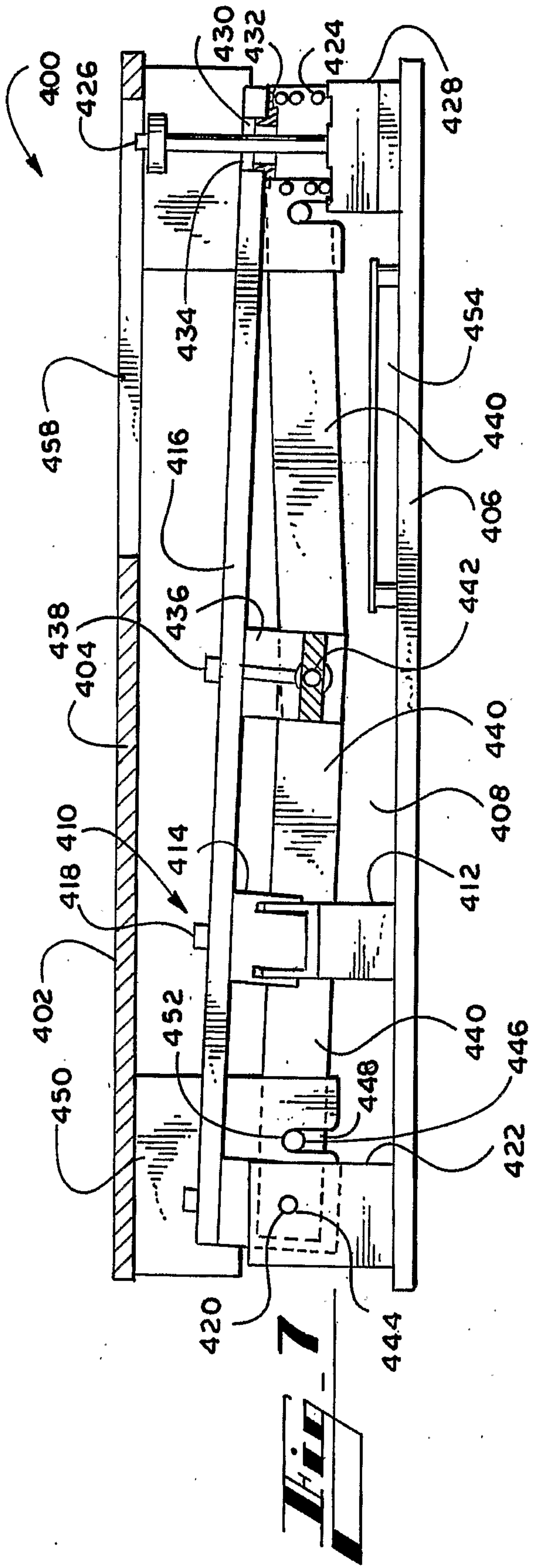

Fig. 4





6/7

