

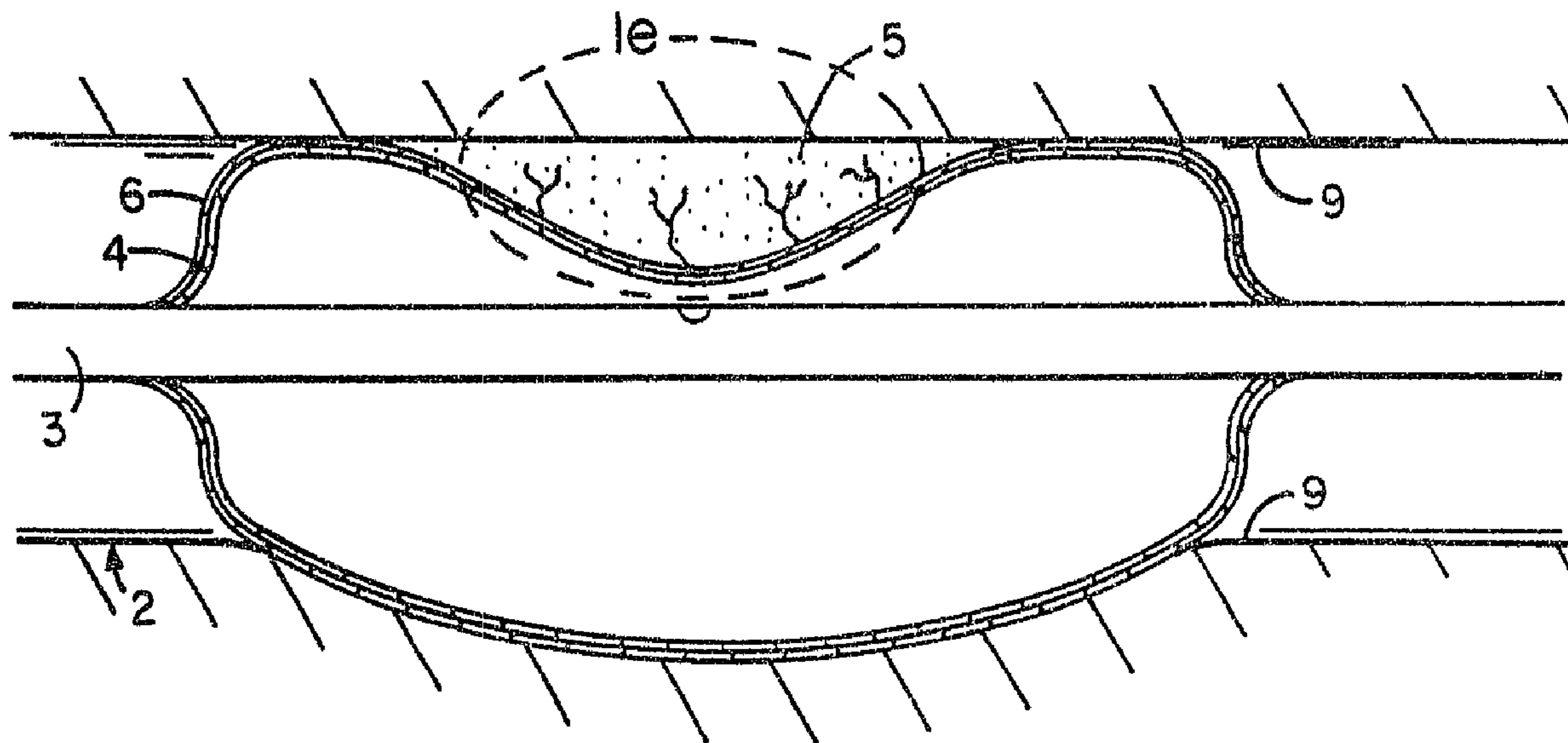

(86) Date de dépôt PCT/PCT Filing Date: 1991/12/27
 (87) Date publication PCT/PCT Publication Date: 1992/07/23
 (45) Date de délivrance/Issue Date: 2002/03/05
 (85) Entrée phase nationale/National Entry: 1993/06/22
 (86) N° demande PCT/PCT Application No.: US 1991/009805
 (87) N° publication PCT/PCT Publication No.: 1992/011896
 (30) Priorités/Priorities: 1990/12/28 (07/635,732) US;
 1991/11/22 (07/795,976) US

(51) Cl.Int.⁵/Int.Cl.⁵ A61M 25/10
 (72) Inventeur/Inventor:
 Sahatjian, Ronald, US
 (73) Propriétaire/Owner:
 BOSTON SCIENTIFIC CORPORATION, US
 (74) Agent: OYEN WIGGS GREEN & MUTALA

(54) Titre : DISPOSITIF POUR L'ADMINISTRATION DE MEDICAMENTS
 (54) Title: DRUG DELIVERY SYSTEM



(57) Abrégé/Abstract:

The invention features a catheter (1) and methods for delivering drug to tissue at a desired location of the wall of a body lumen (2). The catheter (1) is constructed for insertion in a body lumen (2) and has a catheter shaft (3) and an expandable portion (4) mounted on the catheter shaft (3). The expandable portion (4) is expandable to a controlled pressure to fill the cross-section of the body lumen (2) and press against the wall (9) of the body lumen (2). In one embodiment, at least a portion of the exterior surface of the expandable portion (4) is defined by a coating (6) of a tenaciously adhered swellable hydrogel polymer. Incorporated in the hydrogel polymer is an aqueous solution of a preselected drug (8) to be delivered to the tissue or plaque. The hydrogel polymer and drug (8) are selected to allow rapid release of a desired dosage of the drug (8) from the hydrogel polymer coating during compression of the hydrogel polymer coating against the wall (9) of the lumen (2) when the expandable portion (4) is expanded. In other embodiments the polymer is released from the expandable portion (4) in response to pressure, to coat the wall (9) of the body lumen (2).



INTERNATIONAL APPLICATION PUBLISHED UNDER THE PATENT COOPERATION TREATY (PCT)

<p>(51) International Patent Classification ⁵ : A61M 31/00, 29/00, 5/32</p>	<p>A1</p>	<p>(11) International Publication Number: WO 92/11896 (43) International Publication Date: 23 July 1992 (23.07.92)</p>
<p>(21) International Application Number: PCT/US91/09805 (22) International Filing Date: 27 December 1991 (27.12.91) (30) Priority data: 635,732 28 December 1990 (28.12.90) US 795,976 22 November 1991 (22.11.91) US (71) Applicant: BOSTON SCIENTIFIC CORPORATION [US/US]; 480 Pleasant Street, Watertown, MA 02172 (US). (72) Inventor: SAHATJIAN, Ronald ; 29 Saddle Club Road, Lexington, MA 02173 (US). (74) Agent: WILLIAMS, John, N.; Fish & Richardson, 225 Franklin Street, Boston, MA 02110-2804 (US).</p>	<p style="text-align: center; font-size: 2em;">2098984</p> <p>(81) Designated States: AT (European patent), BE (European patent), CA, CH (European patent), DE (European patent), DK (European patent), ES (European patent), FR (European patent), GB (European patent), GR (European patent), IT (European patent), JP, LU (European patent), MC (European patent), NL (European patent), SE (European patent).</p> <p>Published <i>With international search report.</i></p>	

(54) Title: DRUG DELIVERY SYSTEM

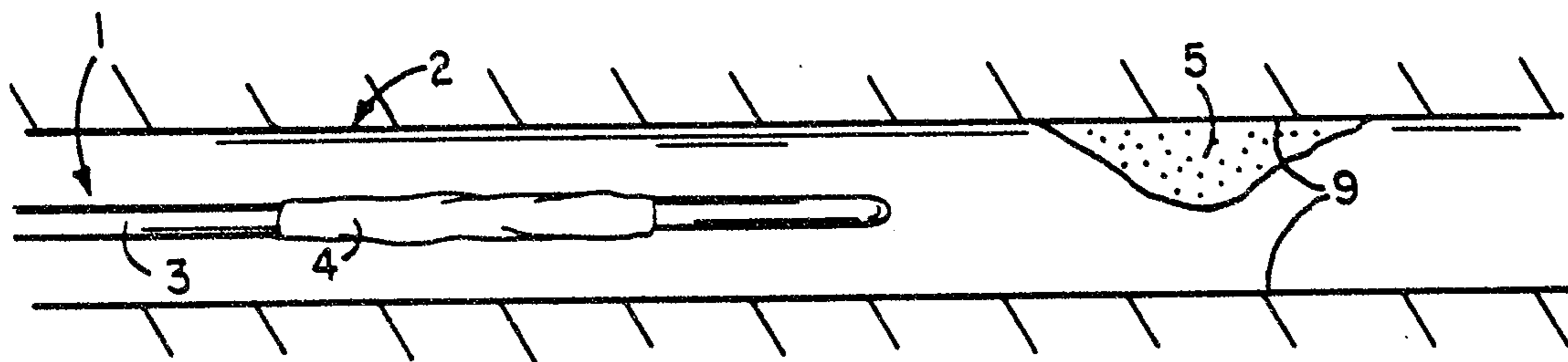

(57) Abstract

The invention features a catheter (1) and methods for delivering drug to tissue at a desired location of the wall of a body lumen (2). The catheter (1) is constructed for insertion in a body lumen (2) and has a catheter shaft (3) and an expandable portion (4) mounted on the catheter shaft (3). The expandable portion (4) is expandable to a controlled pressure to fill the cross-section of the body lumen (2) and press against the wall (9) of the body lumen (2). In one embodiment, at least a portion of the exterior surface of the expandable portion (4) is defined by a coating (6) of a tenaciously adhered swellable hydrogel polymer. Incorporated in the hydrogel polymer is an aqueous solution of a preselected drug (8) to be delivered to the tissue or plaque. The hydrogel polymer and drug (8) are selected to allow rapid release of a desired dosage of the drug (8) from the hydrogel polymer coating during compression of the hydrogel polymer coating against the wall (9) of the lumen (2) when the expandable portion (4) is expanded. In other embodiments the polymer is released from the expandable portion (4) in response to pressure, to coat the wall (9) of the body lumen (2).

- 1 - 2098984

DRUG DELIVERY SYSTEMField of the Invention

The invention relates to delivery of drugs to the walls of body lumens.

Background of the Invention

Systemic administration of drugs treats the organism as a whole, even though the disease may be localized, such as occlusion of a duct or vessel. Localization of a drug poses special problems in cases involving the walls of ducts and vessels, since, by nature, these organs serve as transport systems.

Arthrosclerotic disease, for example, causes localized occlusion of the blood vessels resulting from the build-up of plaque. As the deposits increase in size, they reduce the diameter of the arteries and impede blood circulation. Angioplasty, which involves the insertion of catheters, such as balloon catheters, through the occluded region of the blood vessel in order to expand it, has been used to treat arthrosclerosis.

The aftermath of angioplasty in many cases is problematic, due to restenosis, or closing of the vessel, that can occur from causes including mechanical abrasion and the proliferation of smooth muscle cells stimulated by the angioplasty treatment. Restenosis may also occur as a result of clot formation following angioplasty, due to injury to the vessel wall which triggers the natural clot-forming reactions of the blood.

Summary of the Invention

In one aspect, the invention features a catheter and method for delivering drug to tissue at a desired location of the wall of a body lumen. The catheter is constructed for insertion in a body lumen and has a catheter shaft and an expandable portion mounted on the catheter shaft. The expandable portion is expandable to

a controlled pressure to fill the cross-section of the body lumen and press against the wall of the body lumen. At least a portion of the exterior surface of the expandable portion is defined by a coating of a tenaciously adhered swellable hydrogel polymer. Incorporated in the hydrogel polymer is an aqueous solution of a preselected drug to be delivered to the tissue. The hydrogel polymer and drug are selected to allow rapid release of a desired dosage of the drug from the hydrogel polymer coating during compression of the hydrogel polymer coating against the wall of the lumen when the expandable portion is expanded.

Various embodiments may include one or more of the following features. The catheter is adapted for insertion in a blood vessel, and the expandable portion is an inflatable dilatation balloon adapted for inflation at pressures in the range for effecting widening of a stenosed blood vessel. The pressure is in the range of about 1 to 20 atmospheres. The hydrogel polymer and drug are effective to release about 20% or more of the drug during inflation in the pressure range. The compression is effective to deliver the drug over a duration of about 10 minutes or less. The hydrogel polymer coating is about 10 to 50 microns thick in the swelled, uncompressed state. The hydrogel polymer is selected from the group consisting of polycarboxylic acids, cellulosic polymers, gelatin, polyvinylpyrrolidone, maleic anhydride polymers, polyamides, polyvinyl alcohols, and polyethylene oxides. The hydrogel polymer is polyacrylic acid. The drug is an anti-thrombogenic drug selected from the group consisting of heparin, Pebac, enoxaprin, aspirin and hirudin. The drug is an anti-proliferative drug selected from the group consisting of monoclonal antibodies, capable of blocking smooth muscle cell proliferation, heparin, angiopeptin and enoxaprin. The expandable portion is

- 3 - 2098984

adapted for application of heat to the polymer material to control the rate of administration. The catheter further comprises a sheath member, extendable over the balloon to inhibit release of the drug into body fluids during placement of the catheter. The balloon catheter is a perfusion catheter having an expandable balloon. The expandable portion includes a stent, mountable in the blood vessel by expansion thereof. The drug is bound in the hydrogel polymer for slow time release of the drug after the compression of the hydrogel polymer by the expansion. The hydrogel polymer is a polyacrylic acid including an ammonium anion and the drug is heparin. The stent is expandable by a balloon. The catheter where the stent and balloon both include the swellable hydrogel coating incorporating the drug. The expandable portion is prepared by introducing an aqueous solution of the drug to the hydrogel polymer coating, the catheter is introduced to the body lumen to position the expandable portion at the point of desired drug application, and the expandable portion is expanded to enable delivery of the drug by compression of the hydrogel polymer coating against the wall at the body lumen. The expandable portion is positioned at a point of occlusion in the blood vessel and expanding the expandable portion at pressures sufficient to simultaneously dilate the vessel and deliver the drug by compression of the hydrogel polymer coating.

In a particular aspect, the invention includes a balloon catheter for delivering drug to tissue at a desired location of the wall of a blood vessel. The catheter is constructed for insertion in a blood vessel and has a catheter shaft and an expandable dilatation balloon mounted on the catheter shaft. The expandable balloon is expandable by an expansion controller to engage the tissue at a controlled pressure in the range

of about 1 to 20 atmospheres to fill the cross-section of the blood vessel and press against the wall of the blood vessel. At least a portion of the exterior surface of the expandable balloon is defined by a coating of a tenaciously adhered swellable hydrogel polymer with a thickness in the range of about 10 to 50 microns in the swelled state, and incorporated within the hydrogel polymer coating, an aqueous solution of a preselected drug to be delivered to the tissue. The hydrogel polymer and drug are selected to allow rapid release of a desired dosage of about 20% or more of the drug solution from the hydrogel polymer coating during compression of the hydrogel polymer coating against the wall of the vessel when the expandable portion is expanded in the pressure range.

In various embodiments, the hydrogel polymer is selected from the group consisting of polycarboxylic acids, cellulosic polymers, gelatin, polyvinylpyrrolidone, maleic anhydride polymers, polyamides, polyvinyl alcohols, and polyethylene oxides. The hydrogel polymer is polyacrylic acid. The drug is an anti-thrombogenic drug selected from the group consisting of heparin, Pebac, enoxaprin, aspirin and hirudin. The drug is an anti-proliferative drug selected from the group consisting of monoclonal antibodies, capable of blocking smooth muscle cell proliferation, heparin, angiopeptin and enoxaprin. The catheter further comprises a sheath member, extendable over the balloon to inhibit release of the drug into body fluids during placement of the catheter.

In another aspect, the invention features a catheter for delivering drug to tissue at a desired location of the wall of a body lumen, comprising. The catheter is constructed for insertion in a body lumen having a catheter shaft and an expandable portion mounted

on the catheter shaft, the expandable portion is expandable to a controlled pressure to fill the cross-section of the body lumen and press against the wall of the body lumen. At least a portion of the exterior surface of the expandable portion is defined by a coating of a body-fluid soluble polymer, and incorporated within the soluble polymer, a preselected drug to be delivered to the tissue. The soluble polymer and drug are selected to allow release of the polymer from the surface of the balloon during compression of the polymer coating against the wall of the body lumen when the expandable portion is expanded to coat the wall of the body lumen.

Various embodiments include the following. The polymer is selected from the group consisting of polycaprolactone, polyorthoesters, polylactic acids, polyglycolic acids, and albumin. The catheter where the drug is selected from anti-thrombogenic drugs and anti-proliferative drugs. The catheter where the expandable portion is adapted for application of heat to the polymer material to control the rate of administration. The catheter where the polymer is a meltable polymer, and the release of the polymer is aided by the application of heat.

In general, an advantage of the invention is the application of drugs by active diffusion directly into the tissue within the body requiring treatment. The drug is preferably applied in a rapid but low-stress, low energy manner that does not further injure the tissue to be treated, and administration is selectively and evenly distributed over the treated area such that the drug can be taken up by tissue and plaque, without, e.g., being washed away by body fluids.

Description of Preferred Embodiments

We first briefly describe the drawings.

2098984

- 6 -

Drawings

Figs. 1-1a are enlarged views of a method of preparing an embodiment of the invention.

5 Fig. 1b is an enlarged cross-sectional view of an embodiment of the drug delivery balloon catheter of the invention being moved through a vessel toward an occlusion to be treated.

10 Fig. 1c is an enlarged cross-sectional view of the balloon in Fig. 1b, now fully inflated and at the site of occlusion.

Fig. 1d is a further enlarged, schematic cross-sectional view of the portion of Fig. 1c indicated in the circle 1e, but taken prior to full inflation.

15 Fig. 1e, which corresponds to the portion of Fig. 1c indicated in the circle 1e, is an enlarged, schematic cross-sectional view, as in Fig. 1d, but with the balloon under full inflation to release the drug coated on the balloon.

20 Fig. 2 is an enlarged cross-sectional view of another embodiment of the drug delivery balloon catheter of the invention including a sheath for covering the catheter as it is being moved through a vessel toward the occlusion to be treated.

25 Fig. 2a is an enlarged cross-sectional view of the catheter of Fig. 2 with the sheath retracted and balloon inflated at the site of occlusion.

30 Fig. 3 is an enlarged, schematic cross-sectional view of another embodiment of the drug delivery balloon catheter in which the drug, originally held within a polymer applied to a thermal balloon of the invention, is now entering the surrounding tissue.

35 Fig. 3a is a further enlarged, schematic illustration of the embodiment of Fig. 3 and illustrates the entry of the drug, shown as circles, into the surrounding tissue.

- 7 -

Figure 4 shows a balloon catheter with the hydrogel and drug coated endoprosthesis mounted on the balloon section, in the region of the thrombus, before radial expansion of the balloon section and endoprosthesis.

Figure 4a is an enlargement of Figure 4 showing the hydrogel polymer and drug coated endoprosthesis and Fig. 4b is a cross-section along the line b-b in Fig. 4a.

Figure 5 shows the endoprosthesis compressed against the vessel wall by radial expansion of the balloon section with the drug diffused into the compressed thrombus before removal of the balloon catheter.

Figure 6 shows the endoprosthesis positioned against the drug inside the compressed thrombus, after removal of the balloon catheter.

General Description

Referring to Figs. 1-1e, in one embodiment, the invention includes a drug delivery balloon catheter device 1 comprising a catheter body 3 having a balloon 4 attached at its distal end. The balloon 4 on the catheter 3 includes a swellable hydrogel polymer coating 6. As shown in Figs. 1-1a, a drug 8 in an aqueous solution is absorbed into the hydrogel with the balloon in the deflated state prior to insertion into the patient by the physician, e.g., the hydrogel-coated balloon may be immersed in a small tube or vial containing the drug. The drug may also be applied in the form of droplets, such as from an eyedropper, or the drug may be precipitated into the hydrogel prior to sterilization and sold as a finished device. Exposure of the hydrogel to the solution causes the hydrogel to swell.

As shown in Fig. 1b, typically the device 1 is inserted into the duct or vessel 2 having a region to be treated, such as an occlusion due to a deposition of

5 plaque 5 on the vessel wall tissue 9. The device 1 is
moved along the vessel to position the balloon 4 at the
occlusion site, as shown in Fig. 1c. The vessel may be,
for example, a narrow, tortuous opening through which the
catheter is passed by torquing from the distal end. As
the balloon is inflated the pressure created by the
balloon against the tissue compresses the hydrogel and
the drug is quickly and freely released for transfer by
active diffusion into the plaque and tissue. The
10 pressure applied to the plaque and tissue by the
expansion of the balloon during application of the drug
enhances transfer of the drug into the tissue and plaque.
This process is referred to here as active diffusion.
The balloon and catheter may be exposed to the body
15 fluids of the lumen for a considerable time, e.g., up to
about 15 minutes in some angioplasty procedures. An
advantage of this invention is that large amounts of the
drug, e.g., greater than 20%, even 30-50% or more, of the
drug solution contained in the hydrogel, is diffused into
20 the effected area in the short time duration which the
hydrogel is compressed, e.g., 2-10 minutes after the
balloon is inflated at the treatment site. The inflation
pressure needed to dilate the vessel which also
approximates the compression of the coating, is in the
25 range of 1 to 20, typically about 2 to 10 atmospheres.
The balloon is preferably a compliant material such as
polyethylene which conforms to the shape of the lumen
wall. The balloon may also be formed of other materials
used in angioplasty, e.g., a nondistending material, such
0 as polyethylene terephthalate (PET). Transporting the
drug in the hydrogel prevents substantial release of the
drug to body fluids prior to reaching the treatment area
and during the drug application phase and allows large
dosages to be delivered at a desired location.

- 9 - 2098984

In the embodiment of Fig. 1c, the balloon coating 6 is a swellable, compressible coating formed of the hydrogel and drug in solution. In Fig. 1d, the balloon 4 is shown inflated such that the coating 6, which has an initial thickness, is in contact with the occlusion 5 but not under substantial pressure. Further inflation of the balloon 4, as shown in Fig. 1e, compresses the hydrogel coating 6 against the occluded areas 5 causing quick release of the drug (represented by circles) contained in the coating 6 directly into the plaque and nearby healthy tissue, as indicated by the directional arrows, much in the nature of squeezing liquid from a sponge. The introduction of the drug into the plaque and tissue occurs simultaneously with widening of the occlusion by the dilatation balloon. Thus, as cracking of the plaque and stimulation of smooth muscle cells beneath the plaque and along healthy tissue of the vessel wall are caused by dilatation, a therapeutic drug is simultaneously applied to the effected area, e.g., to counteract the effects of the trauma. The thickness of the balloon 4 remains substantially the same, while the thickness of the coating 6 decreases due to the compression of the coating and the release of the drug 8. (Figs. 1d-1e are schematic drawings and are not to scale with respect to the thickness of the balloon relative to the thickness of the hydrogel coating.) The drug carried by the balloon is evenly applied to plaque and tissue and isolated by the pressure of the balloon from the flow of body fluids in the lumen such that the drug, e.g., an anti-proliferative, may actively diffuse through the cracks formed in the plaque and reach the smooth muscle tissue. (It will also be understood that, as an alternative procedure, after dilation with a conventional angioplasty balloon catheter, a catheter carrying a drug-delivery,

inflatable balloon, such as has been described, may be used to treat the vessel.)

The hydrogel coating is characterized by the ability to incorporate a substantial amount of the drug, typically in aqueous solution form, and is swellable such that the aqueous drug solution can be effectively squeezed out of the coating when pressure is applied by inflation of the balloon. Administration of the drug in this way enables the drug to be site specific, such that release of high concentrations and/or highly potent drugs may be limited to direct application to the diseased tissue. Furthermore, the drug is applied to the diseased tissue by the sponge-like coating in an even, gentle manner without disrupting or injuring the healthy tissue, while diffusion of the drug into the tissue is facilitated by the application of the pressure of the inflated balloon. The pressure also effectively forms a seal that prevents the flow of body fluids from washing the drug downstream of the treatment area. The dosage applied to the tissue may be controlled by regulating the time of presoaking the drug into the hydrogel coating to determine the amount of absorption of the drug solution by the hydrogel coating. Other factors affecting the dosage are the concentration of the drug in the solution applied to the coating and the releasability of the hydrogel coating, determined by, for example, the thickness of the hydrogel coating, its resiliency, porosity and the ability of the hydrogel coating to retain the drug, e.g., electrostatic binding or pore size, or the ionic strength of the coating, e.g., changed by changing the pH.

The drug may be an anti-thrombogenic drug, such as heparin or a heparin derivative, Pebac (dextrophenylalanine proline arginine chloromethylketone) or an anti-proliferative, such as heparin (also known to

have anti-proliferative properties), enoxaprin, angiopeptin, or monoclonal antibodies capable of blocking smooth muscle cell proliferation, or it may be hirudin or acetylsalicylic acid (i.e., aspirin). Dosages applied to the tissue, for example, of heparin are typically in the range of 10-30 mg of heparin solution containing 200-1,000 units of sodium heparin. For use with hydrogels, the drug is preferably water soluble, so that the drug may be easily absorbed into the coating matrix.

The sponge-like characteristics of the hydrogel allows the aqueous drug solution to be effectively squeezed out of the coating when pressure is applied by inflation of the balloon. The hydrogel and drug combination are preferably noncomplexed, i.e., held together through the ability of the hydrogel to swell and absorb the drug solution, thereby allowing the preferable free-release of the drug at the treatment site.

In particular embodiments it may be advantageous to select a hydrogel coating for a particular drug such that the drug is not substantially released into body fluids prior to application of pressure by expansion of the balloon. Binding of the drug may also be accomplished by electrostatic attraction of the drug to the coating or a coating additive or by mechanical binding, e.g., employing a coating having a pore size that inhibits inward flow of body fluids or outward flow of the drug itself, that might tend to release the drug. Hydrogels are particularly advantageous in that the drug is held within the hydrogen-bond matrix formed by the gel.

The hydrogel is a cross-linked polymer material formed from the combination of a colloid and water. Cross-linking reduces solubility and produces a jelly-like polymer that is characterized by the ability to swell and absorb a substantial amount of the drug,

- 12 -

typically in aqueous solution form. The hydrogel coating is also particularly hydrophilic, water swellable, and lubricous (i.e., having a low coefficient of friction). Preferred hydrogels are polyacrylic acid polymers available as HYDROPLUS® (Boston Scientific, Watertown, MA) and as described in U.S. Patent No. 5,091,205.

The drug, e.g., heparin in aqueous solution, is absorbed into the coating without complexing and is freely released therefrom. Such hydrogel-drug combinations deliver about half of the drug solution in response to pressures in the range of balloon angioplasty in the vascular system. In other particular embodiments, the hydrogel polymer includes acid groups and incorporates a drug which is anionic in nature that is bound by electrostatic attraction to cations in the coating, such as an ammonium cation, as described in "Lubricous Antithrombogenic Catheters, Guidewires, and Coatings," by Ronald Sahatjian et al. U.S. patent No. 5,135,516.

(see also corresponding International Publication No. WO91/08790, published June 27, 1991). The coating incorporating the quaternary ammonium salt is effective to deliver an initial fast release of drug during compression and a slow release of drug remaining in the compressed coating after compression and is particularly useful for coating vascular stents as described further below.

In general, when dry, the hydrogel coating is preferably on the order of about 1 to 10 microns thick, with a 2 to 5 micron coating typical. Very thin hydrogel coatings, e.g., of about .2-.3 microns (dry) and much thicker hydrogel coatings, e.g., more than 10 microns (dry), are also possible. Typically, the hydrogel

- 13 -

coating thickness may swell by about a factor of 6 to 10 or more when the hydrogel coating is hydrated. For example, a hydrogel coating of about 1 to 3 microns thickness, when dry, usually swells to about 10-30
5 microns thickness, when hydrated. Most preferably, the thickness of the coating is about 10 to 50 microns in the swelled, uncompressed state, and incorporates about 20-30mg of drug solution.

10 Referring to Fig. 2, in another embodiment of a drug delivery balloon catheter, the catheter 3 is preferably very small in diameter and flexible, much in the nature of a guidewire, formed, in this case, of hollow tubing to which the coated balloon 4 is attached. The balloon is covered by a protective sheath 7 while the
15 instrument I is inserted into the vessel or duct 2 and positioned at the treatment region. As the coated balloon 4 is positioned at the occluded site 5, (Fig. 2a) the protective sheath 7 is drawn back to expose the balloon 4. In an alternative embodiment, the sheath
20 remains stationary while the guidewire-like catheter moves the coated balloon forward into the occluded region. The sheath 7 protects the coating and inhibits premature release of the drug. Such a sheath might be particularly advantageous with coatings and drugs without
25 substantial chemical or mechanical binding. Additionally, the balloon catheter may be a thermal balloon catheter with electrodes 43, as more fully described below. The application of such heat may be employed to facilitate the release of the drug from the
30 coating, to facilitate penetration of the drug into the tissue, or to facilitate the therapeutic action of the drug.

A procedure for preparing a drug delivery balloon with a hydrogel coating and an experiment of drug

- 14 -

delivery for the above embodiments are presented in the following examples.

Examples

Example 1

5 A hydrogel coating on an angioplasty balloon may be formed as follows. The surface of the balloon (polyethylene) of an angiographic catheter is prepared by wiping down with clean cloth. The balloon has an O.D. (outer diameter) of about 3.5 mm (inflated). The balloon is coated with a solution of 4,4' diphenylmethane diisocyanate (MDI) in methylethylketone for 30 minutes. After drying in an air oven at 85° C for 30 minutes, the balloon is dipped in a 1.7% solution of poly(acrylic acid) homopolymer having a molecular weight of about 10 3,000,000 in dimethylformamide (DMF) and tertiarybutyl alcohol. After drying at about 85° C for 30 minutes, a smooth coating is obtained. The balloon is oven dried for 8 hours at 50° C. One function of the drying steps is to remove solvent from the coating. The surface of the balloon becomes instantly lubricous upon exposure to water. The polyisocyanate solution is at a concentration of about .5 to 10% by weight. The polyacrylic acid is at a concentration of about .1 to 10% by weight. The poly(carboxylic acid) to polyisocyanate molar ratio is generally about 1:1. The formation of the hydrogel is further described in U.S. patent No. 5,091,205 supra.

25 A solution of heparin salt may be applied to the coating. The solution is 10,000 units heparin sodium injection (Fisher Scientific, Pittsburgh, PA) USP Grade 30 (1000 units/ml which is then added to 650cc distilled water) and may be applied by dipping for, e.g., about 1 minute at room temperature. The heparin does not form a complex with the hydrogel solution and is freely released in response to compression of the polymer.

After a catheter is prepared for use as discussed above, the catheter may be introduced into the patient using the Seldinger technique and expanded at a desired location to compress the hydrogel and deliver the heparin solution.

Example 2

Delivery of a drug from a hydrogel coating on a balloon was investigated in the following experiment. Tritium-labeled Pebac was absorbed into a 3.5 mm Slider® (balloon catheter from Boston Scientific Corporation) balloon coated with about a 40 micron thick (in the swelled state) coating as described in Example 1. The coating was dried and the radioactivity was counted. The balloon was then wetted with saline to swell the coating area. The balloon was inflated over a period of about one minute to about 4 atmospheres and held at this pressure for about 10 minutes in a thrombus created in an AV shunt from a baboon. The balloon was withdrawn and the amount of the drug in the thrombus was counted with a radiation counter. The experiment was performed with two different balloons using two different concentrations of Pebac, one balloon with 1-2 mg Pebac, and one balloon with 4mg Pebac. Both balloons delivered about 50% of the Pebac into the thrombus.

Other Embodiments

Referring to Fig. 3, in another embodiment, the drug 44 is held within a polymer coating applied to the exterior of a thermal balloon, central wall portions 42 of which are shown in Fig. 3. The balloon is positioned in the lumen in the region to be treated and inflated such that the polymer coating is in contact with the tissue as shown in Figs. 3-3a. Heating of the balloon 42 melts the polymer and releases the drug 44 in a gentle, even, low-energy manner into the affected tissue. Suitable polymers include, but are not limited to,

- 16 -

albumin, and collagen, e.g., gelatin, such as gel foams, which typically melt between about 40-60° C or polyvinylpyrrolidone (PVP), which dissolves rapidly when heated. The thermal balloon typically operates between
5 40-80° C. A suitable heated balloon system for this embodiment or that of Fig. 2a is discussed in Lennox et al., "Heated Balloon Catheters and the Like," U.S. Patent No. 4,955,377.

10 Inflating liquid is heated as a result of I^2R losses by radiofrequency current flowing in the inflation fluid, e.g., saline, between the electrodes 43 (see Figs. 2a and 3), the liquid in turn heating the balloon wall. In the alternative, drugs which melt and which could be applied either with a meltable or non-meltable polymer binder
15 might be used.

An advantage to the meltable coatings is that the polymer may be cross-linked, (e.g., by physical or chemical cross-linking) after application of the drug 44 to the balloon to inhibit release of the drug 44 as the
20 balloon 42 is introduced through the body lumen to the area of treatment. The polymer itself typically does not melt off the balloon, but rather softens in a manner permitting release. However, in embodiments where the polymer is bioabsorbable, e.g., polycaprolactone,
25 polyorthoesters, polylactic acids, and polyglycolic acids, some or even all of the polymer may dissolve off of the balloon.

The balloon may also be coated with a polymer incorporating a drug and inflated to press against the
30 wall of the body lumen, where the polymer is selected to separate from the balloon and coat the wall of the lumen, in response to such pressure with or without the application of heat from the balloon. After application of the polymer, the balloon can be deflated and removed.
35 In this embodiment, the polymer may be a blood soluble

2098984

polymer such as albumin, collagen or the like, incorporating a drug such as heparin. The polymer produces a smooth coating on the wall of the lumen and releases the drug to the tissue over time as the polymer dissolves. Other soluble polymers are meltable and bioabsorbable polymers discussed above.

In another embodiment (see Figures 4-6) an endoprosthesis (stent) is used in combination with a balloon catheter drug delivery system. An endoprosthesis 50 is placed over the balloon catheter 51, and then coated with a noncomplexed hydrogel coating 52. The drug 8, shown as circles, in aqueous solution is then absorbed into the hydrogel coating 52. The balloon 51 and hydrogel and drug coated endoprosthesis 50 are slid until they reach the region of the occlusion 53 in the vessel 54. This is shown in Fig. 4. An enlargement of the drug and hydrogel polymer coated endoprosthesis 50 is shown in Figs. 4a and 4b (thickness of coating 52 is greatly exaggerated). After the balloon 51 and hydrogel and drug coated endoprosthesis 50 have been positioned inside the vessel 54, the endoprosthesis 50 is radially expanded by the admission of pressure to the balloon 51 and compressed against the vessel wall 54 with the result that occlusion 53 is compressed, and the vessel wall 54 surrounding it undergoes a radial expansion. The pressure from inflating the balloon squeezes the hydrogel 52, freely releasing the drug 8 into the tissue. The endoprosthesis 50 is held in position in the expanded state as shown in Fig. 5. The pressure is then released from the balloon and the catheter is withdrawn from the vessel. Figure 6 shows the drug 8 inside the compressed thrombus with the endoprosthesis expanded and left in position, with the balloon catheter being withdrawn from the lumen. It will be understood that only the endoprosthesis may include the hydrogel polymer coating.

2098984

- 18 -

In the embodiments employing a hydrogel-coated stent, the hydrogel and drug are selected such that an initial high dosage of drug is delivered to adjacent tissue upon initial compression of the polymer and thereafter a slow, sustained time-release of drug remaining in the hydrogel polymer occurs. Preferred hydrogel-drug combinations are those that employ a binding of the drug, such as electrostatic binding, e.g., by using a polyacrylic acid hydrogel in combination with an ammonium cation and heparin. In this case, the coating continues to release drug after expansion of the stent and removal of the balloon catheter. The stent may be a balloon-expandible stent as described above or a self-expanding stent, e.g., of the type formed with superelastic materials such as Nitinol.

Any of the embodiments discussed herein can be used with a protective sheath as described in Figs. 2-2a. In addition, a heated balloon catheter may be used in all combinations of the embodiments above to enhance and control the rate of drug-solution delivery into tissue. Other compressible sponge-like polymers, e.g., non hydrogels which release drug solutions in response to pressure, might be used as described with respect to the embodiment of Fig. 1 et seq.

Still other embodiments are within the claims.

- 19 - 2098984

Claims

1 1. A catheter for delivering drug to tissue at a
2 desired location of the wall of a body lumen, comprising:

3 a catheter constructed for insertion in a body
4 lumen having a catheter shaft and an expandable portion
5 mounted on said catheter shaft, said expandable portion
6 being expandable to a controlled pressure to fill the
7 cross-section of the body lumen and press against the
8 wall of said body lumen,

9 at least a portion of the exterior surface of the
10 expandable portion being defined by a coating of a
11 tenaciously adhered swellable hydrogel polymer, and
12 incorporated within said hydrogel polymer, an aqueous
13 solution of a preselected drug to be delivered to said
14 tissue,

15 said hydrogel polymer and drug selected to allow
16 rapid release of a desired dosage of said drug from said
17 hydrogel polymer coating during compression of said
18 hydrogel polymer coating against the wall of the lumen
19 when said expandable portion is expanded.

1 2. The catheter of claim 1 wherein said catheter
2 is a dilatation catheter adapted for insertion in a blood
3 vessel, and said expandable portion is an inflatable
4 dilatation balloon adapted for inflation at pressures in
5 the range for effecting widening of a stenosed blood
6 vessel.

1 3. The catheter of claim 2 wherein said pressure
2 is in the pressure range of about 1 to 20 atmospheres.

1 4. The catheter of claim 1 or 2 wherein said
2 hydrogel polymer and drug are effective to release about

- 20 -

3 20% or more of said drug during inflation in said
4 pressure range.

1 5. The catheter of claim 1 or 2 wherein said
2 compression is effective to deliver said drug over a
3 duration of about 10 minutes or less.

1 6. The catheter of claim 1 or 2 wherein said
2 hydrogel polymer coating is about 10 to 50 microns thick
3 in the swelled, uncompressed state.

1 7. The catheter of claim 1 or 2 wherein said
2 hydrogel polymer is selected from the group consisting of
3 polycarboxylic acids, cellulosic polymers, gelatin,
4 polyvinylpyrrolidone, maleic anhydride polymers,
5 polyamides, polyvinyl alcohols, and polyethylene oxides.

1 8. The catheter of claim 7 wherein said hydrogel
2 polymer is polyacrylic acid.

1 9. The catheter of claim 1 or 2 wherein said drug
2 is an anti-thrombogenic drug selected from the group
3 consisting of heparin, Pebac, enoxaprin, aspirin and
4 hirudin.

1 10. The catheter of claim 1 or 2 wherein said
2 drug is an anti-proliferative drug selected from the
3 group consisting of monoclonal antibodies, capable of
4 blocking smooth muscle cell proliferation, heparin,
5 angiopeptin and enoxaprin.

1 11. The catheter of claim 1 or 2 wherein said
2 expandable portion is adapted for application of heat to
3 said polymer material to control the rate of
4 administration.

- 21 - 2098984

1 12. The catheter of claim 1 or 2 wherein said
2 catheter further comprises a sheath member, extendable
3 over said balloon to inhibit release of said drug into
4 body fluids during placement of said catheter.

1 13. The catheter of claim 2 wherein said balloon
2 catheter is a perfusion catheter having an expandable
3 balloon.

1 14. The catheter of any one of claims 1 or 2
2 wherein said expandable portion includes a stent,
3 mountable in said blood vessel by expansion thereof.

1 15. The catheter of claim 14 where said drug is
2 bound in said hydrogel polymer for slow time release of
3 said drug after said compression of said hydrogel polymer
4 by said expansion.

1 16. The catheter from claim 15 where said
2 hydrogel polymer is a polyacrylic acid including an
3 ammonium anion and said drug is heparin.

1 17. The catheter of claim 14 wherein said stent
2 is expandable by a balloon.

1 18. The catheter of claim 17 wherein said stent
2 and balloon both include said swellable hydrogel coating
3 incorporating said drug.

1 19. A balloon catheter for delivering drug to
2 tissue at a desired location of the wall of a blood
3 vessel, comprising:

4 a catheter constructed for insertion in a blood
5 vessel having a catheter shaft and an expandable

6 dilatation balloon mounted on said catheter shaft, said
7 expandable balloon being expandable by an expansion
8 controller to engage said tissue at a controlled pressure
9 in the range of about 1 to 20 atmospheres to fill the
10 cross-section of the blood vessel and press against the
11 wall of said blood vessel,

12 at least a portion of the exterior surface of the
13 expandable balloon being defined by a coating of a
14 tenaciously adhered swellable hydrogel polymer having a
15 thickness in the range of about 10 to 50 microns in the
16 swelled state, and incorporated within said hydrogel
17 polymer coating, an aqueous solution of a preselected
18 drug to be delivered to said tissue,

19 said hydrogel polymer and drug selected to allow
20 rapid release of a desired dosage of about 20% or more of
21 said drug solution from said hydrogel polymer coating
22 during compression of said hydrogel polymer coating
23 against the wall of the vessel when said expandable
24 portion is expanded in said pressure range.

1 20. The catheter of claim 19 wherein said
2 hydrogel polymer is selected from the group consisting of
3 polycarboxylic acids, cellulosic polymers, gelatin,
4 polyvinylpyrrolidone, maleic anhydride polymers,
5 polyamides, polyvinyl alcohols, and polyethylene oxides.

1 21. The catheter of claim 19 wherein said
2 hydrogel polymer is polyacrylic acid.

1 22. The catheter of claim 17 or 19 wherein said
2 drug is an anti-thrombogenic drug selected from the group
3 consisting of heparin, Pebac, enoxaprin, aspirin and
4 hirudin.

23. The catheter of claim 17 or 19 wherein said drug is an anti-proliferative drug selected from the group consisting of monoclonal antibodies, capable of blocking smooth muscle cell proliferation, heparin, angiopeptin and enoxaprin.

5 24. The catheter of claim 19 wherein said catheter further comprises a sheath member, extendable over said balloon to inhibit release of said drug into body fluids during placement of said catheter.

10

15

20

25

30

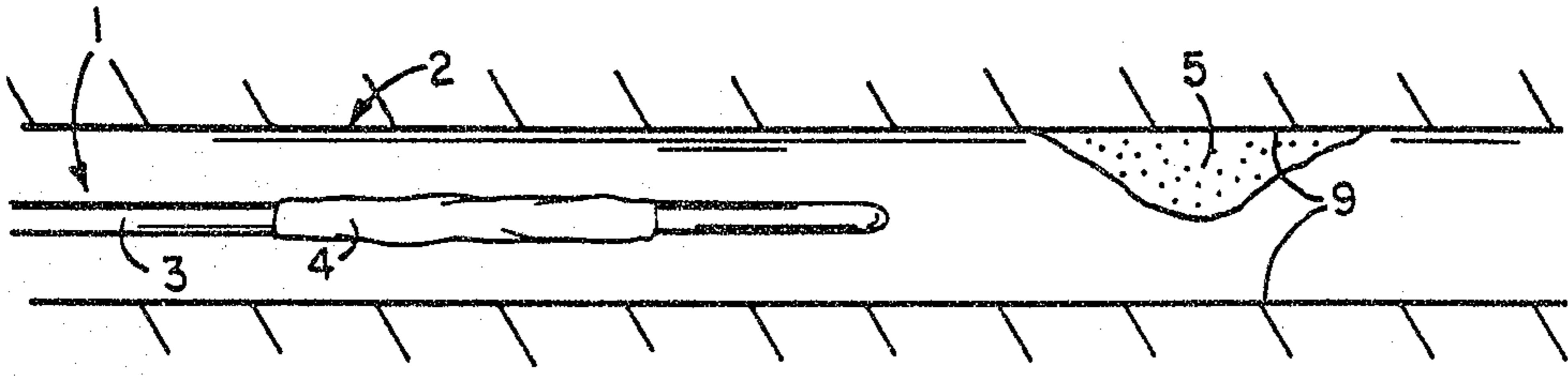
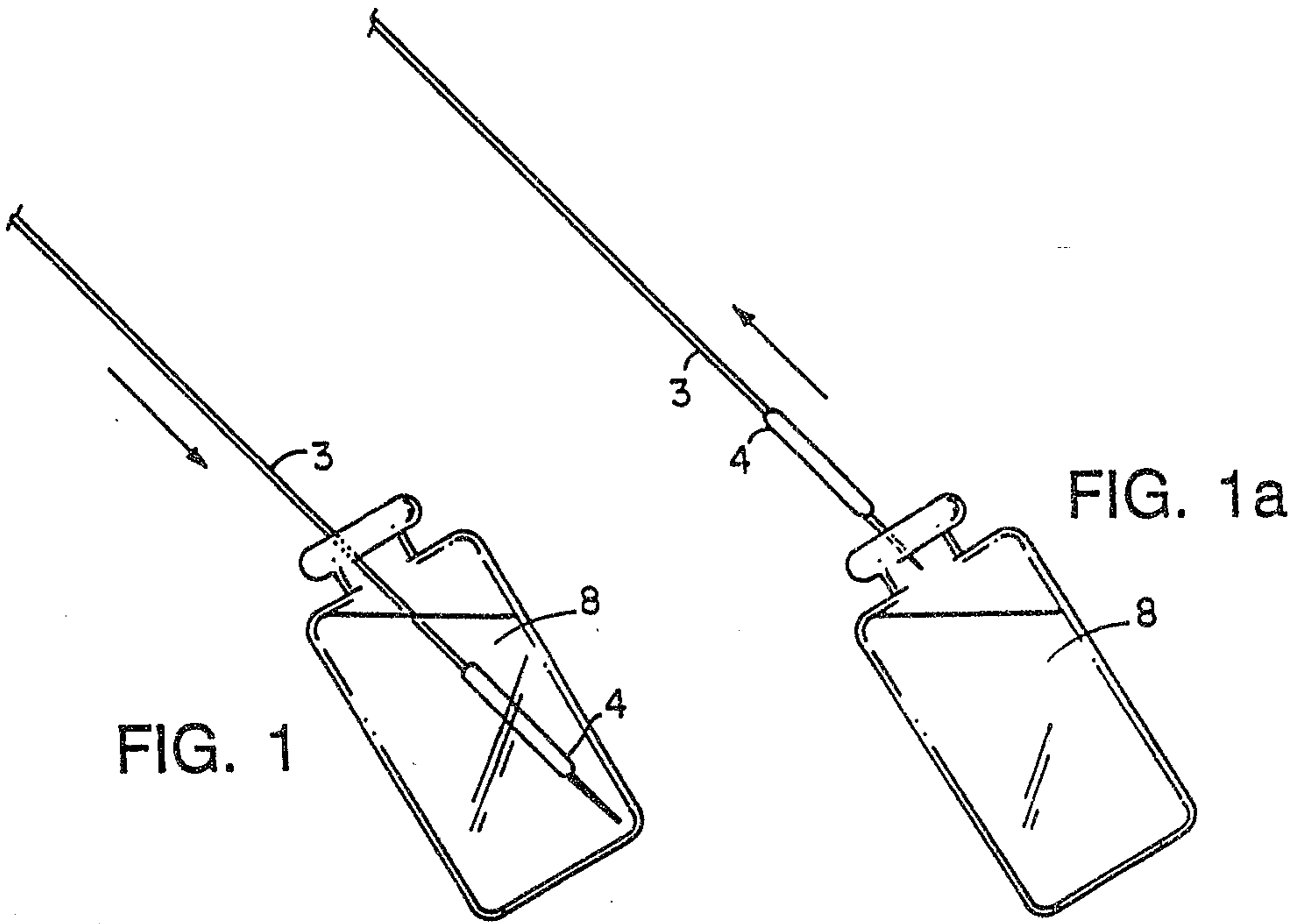

FIG. 1b

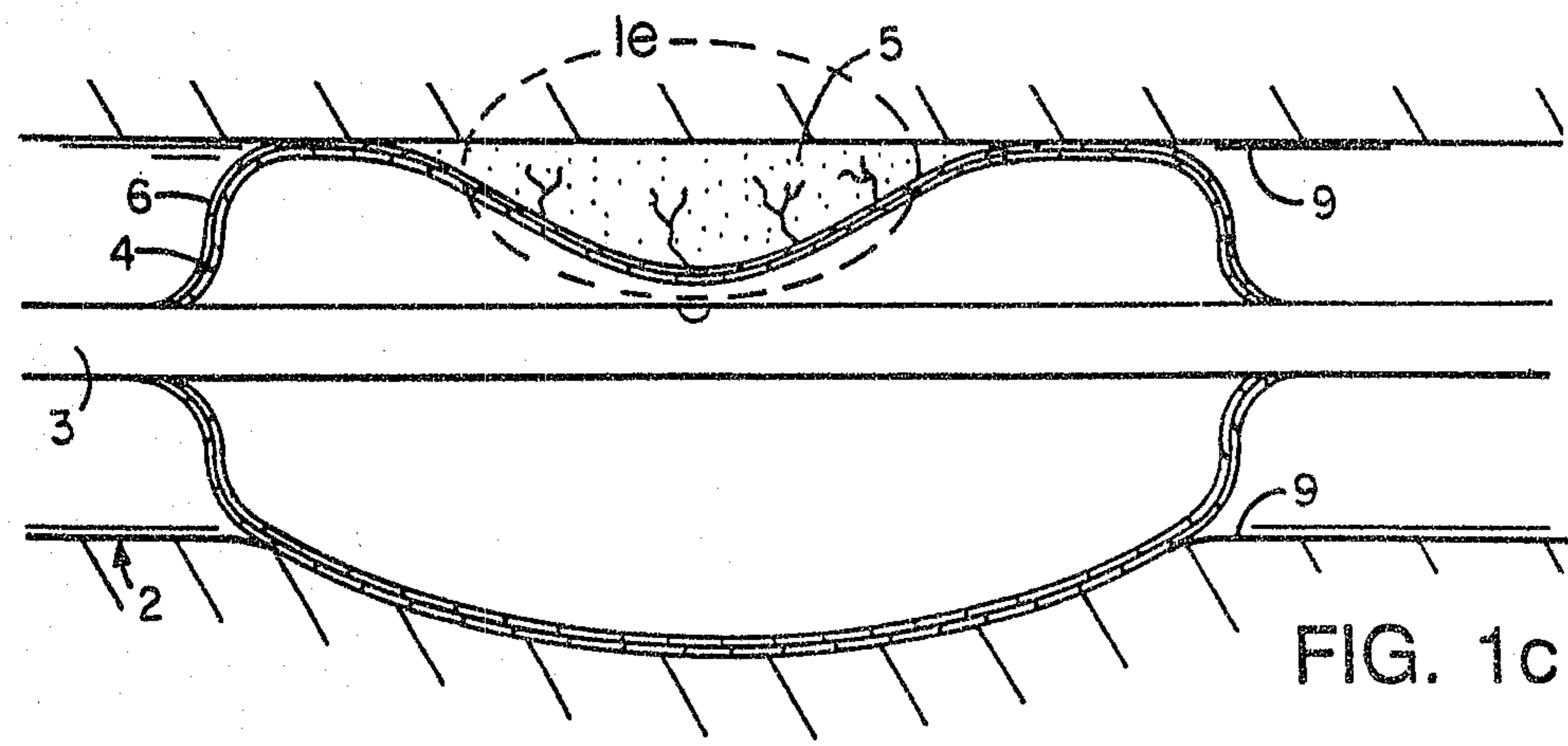

FIG. 1c

SIRSTITITE SHEET

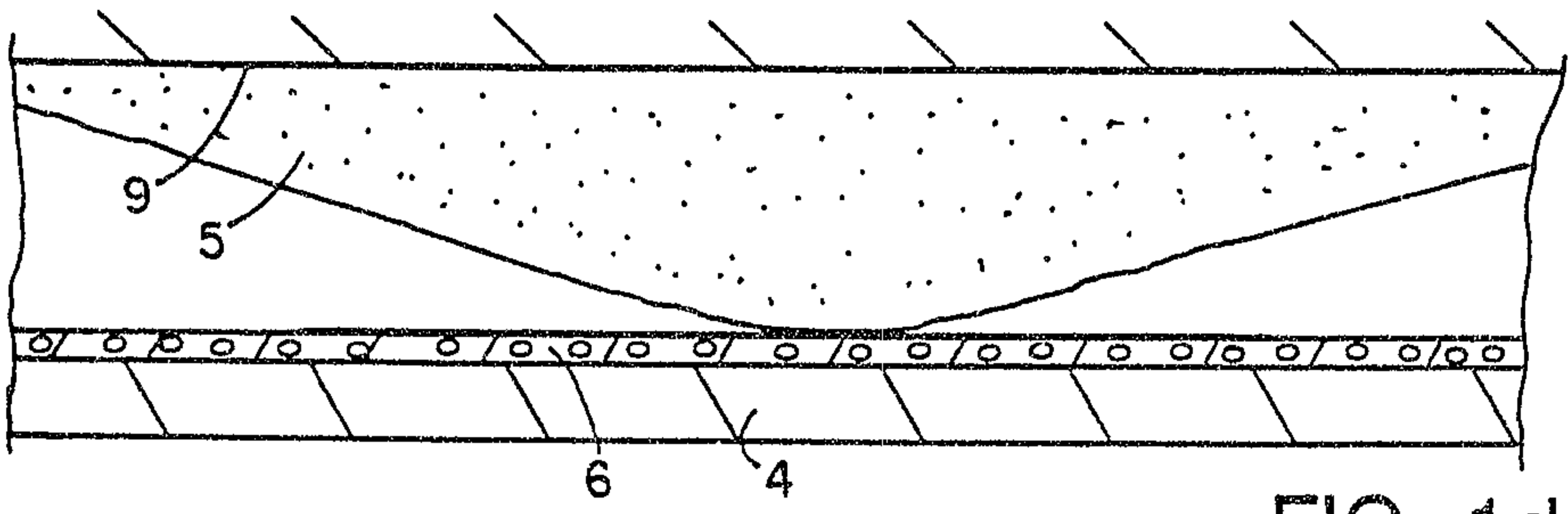

FIG. 1d

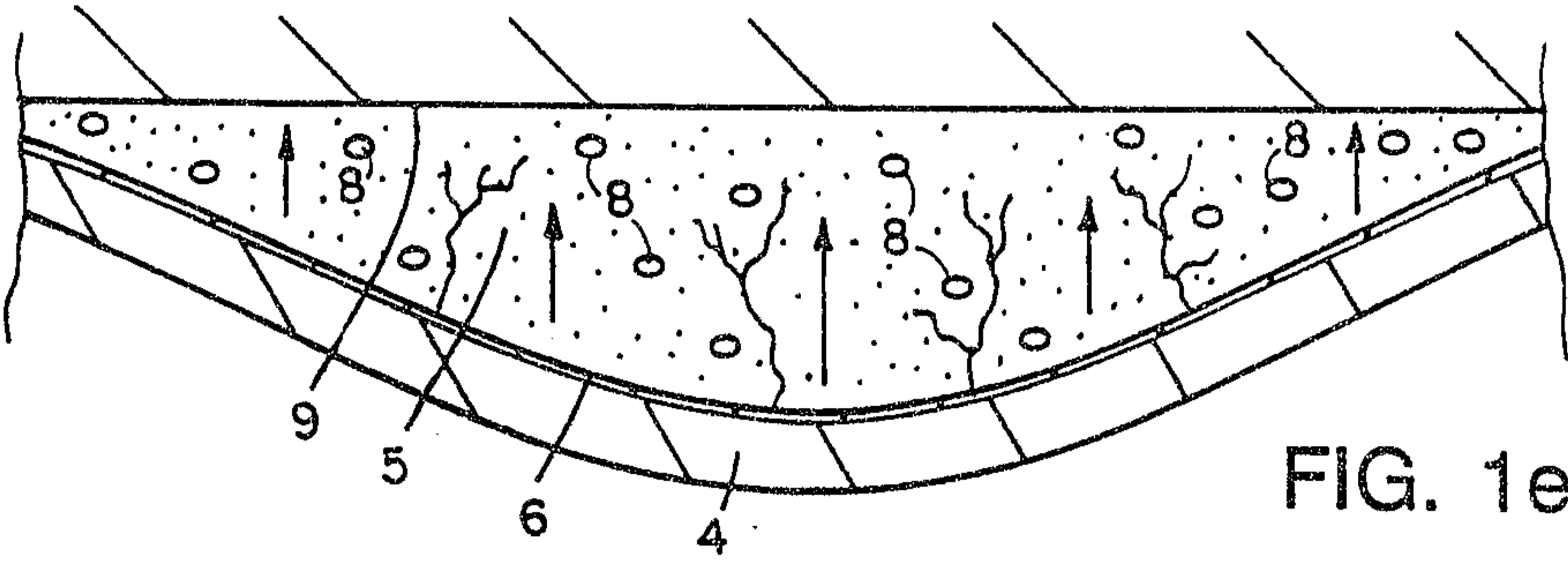

FIG. 1e

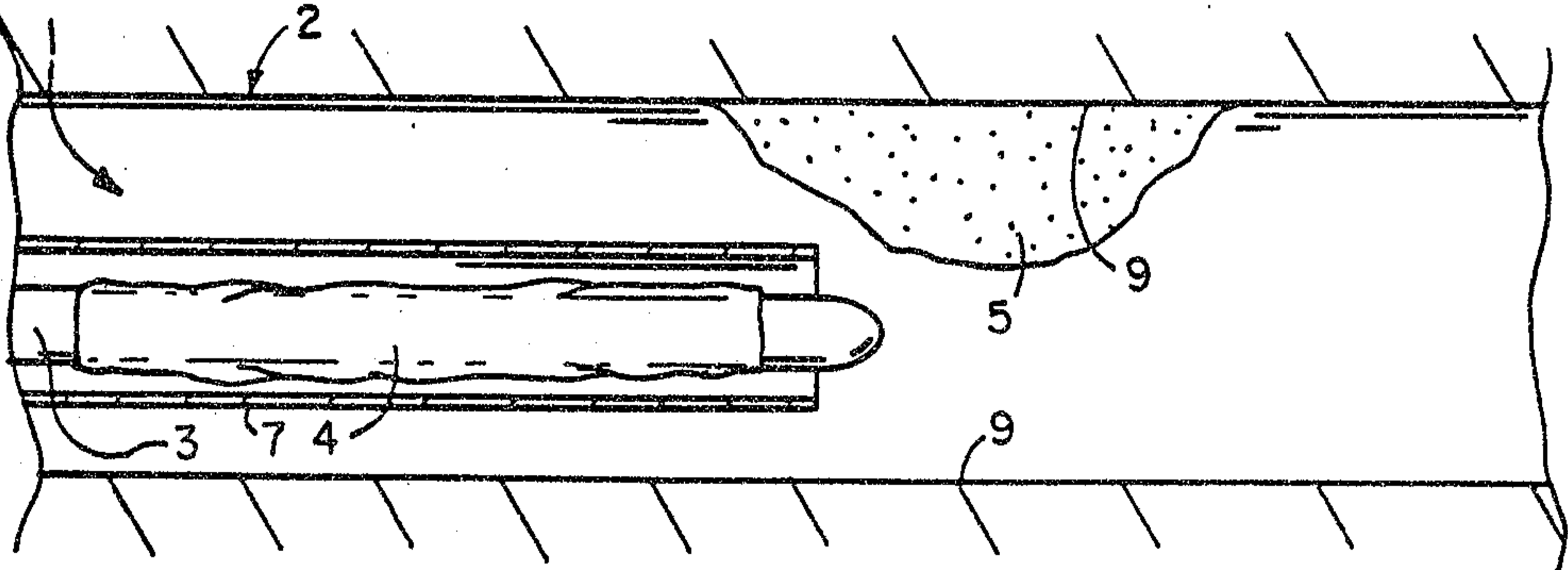

FIG. 2

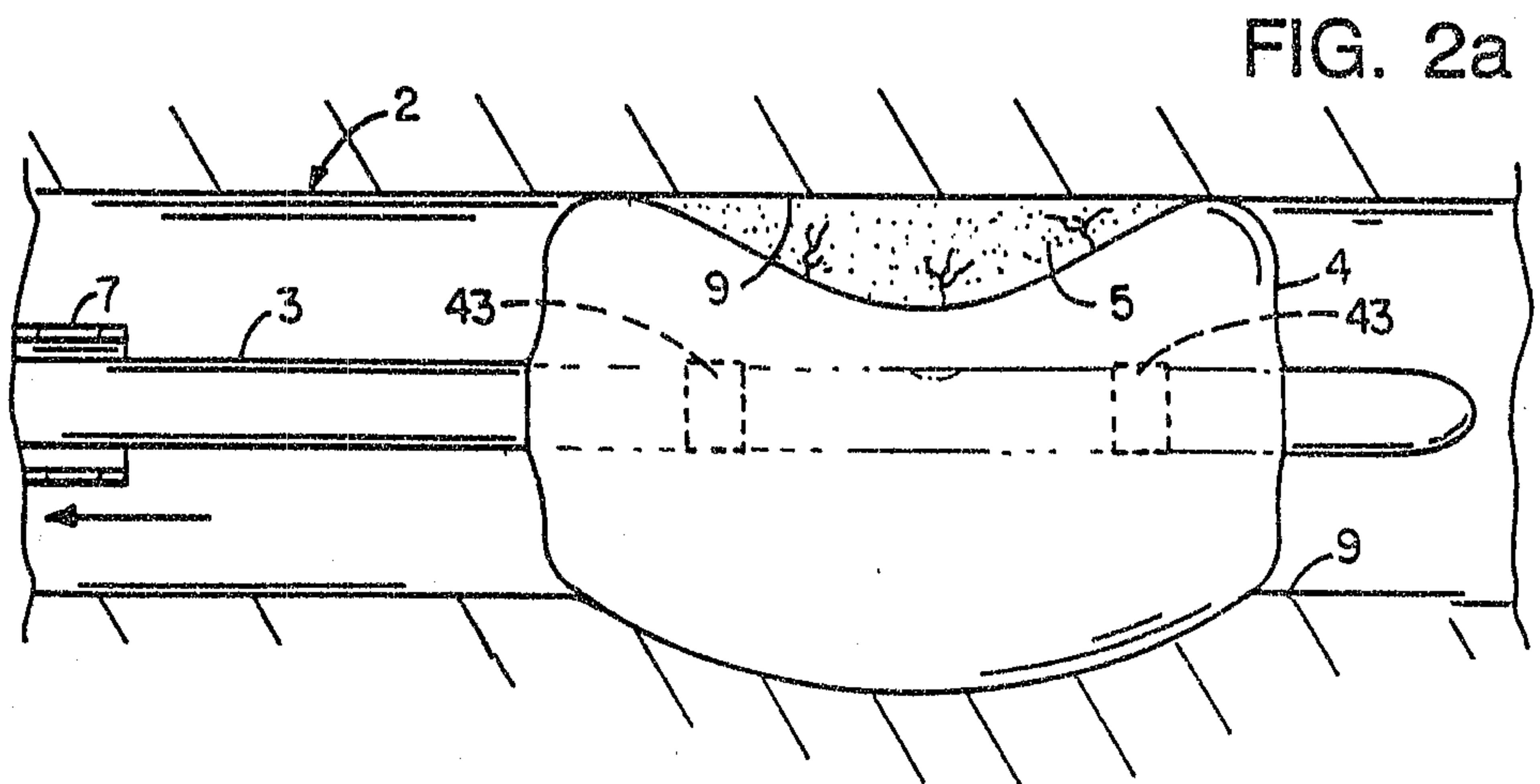

FIG. 2a

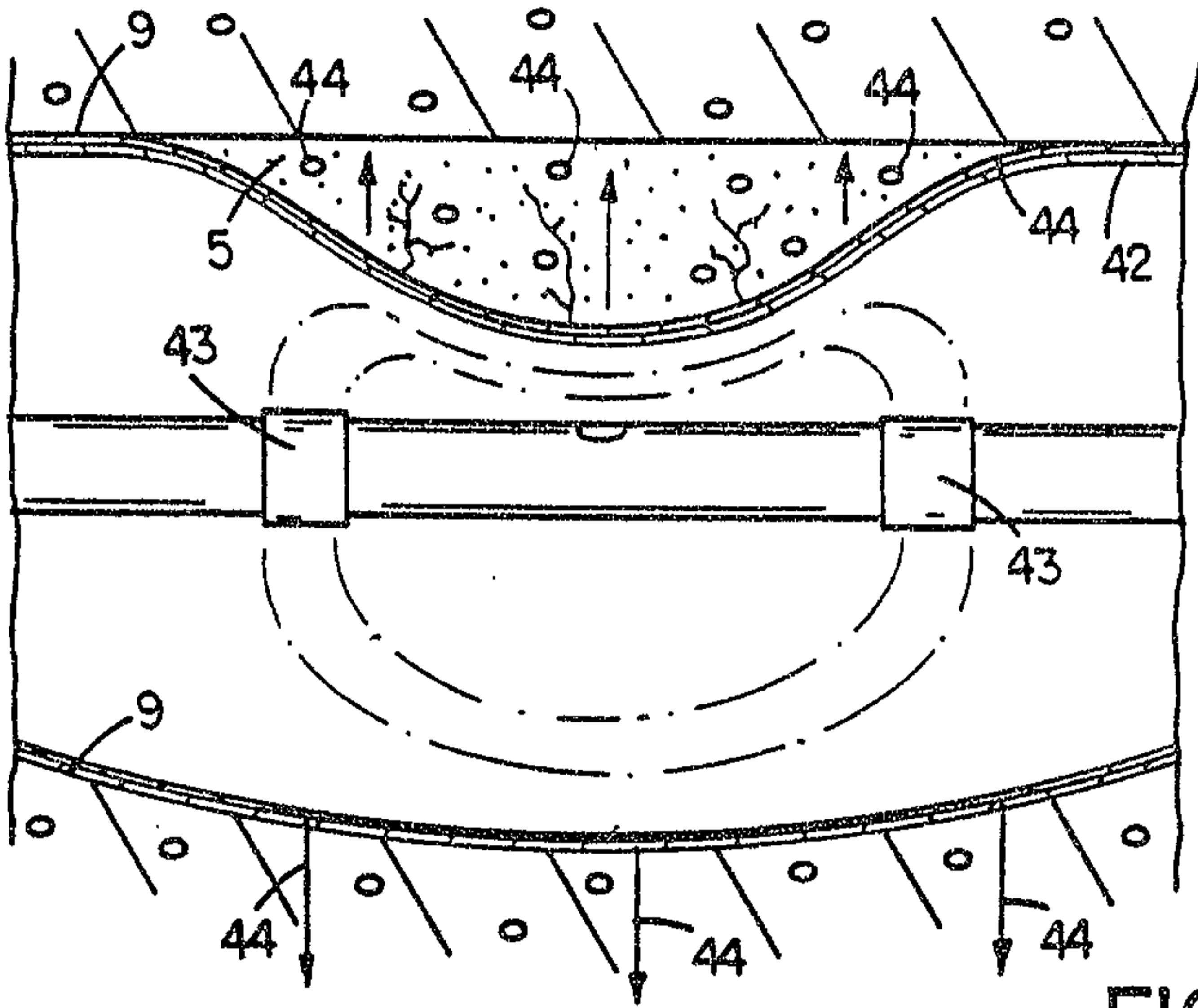

FIG. 3

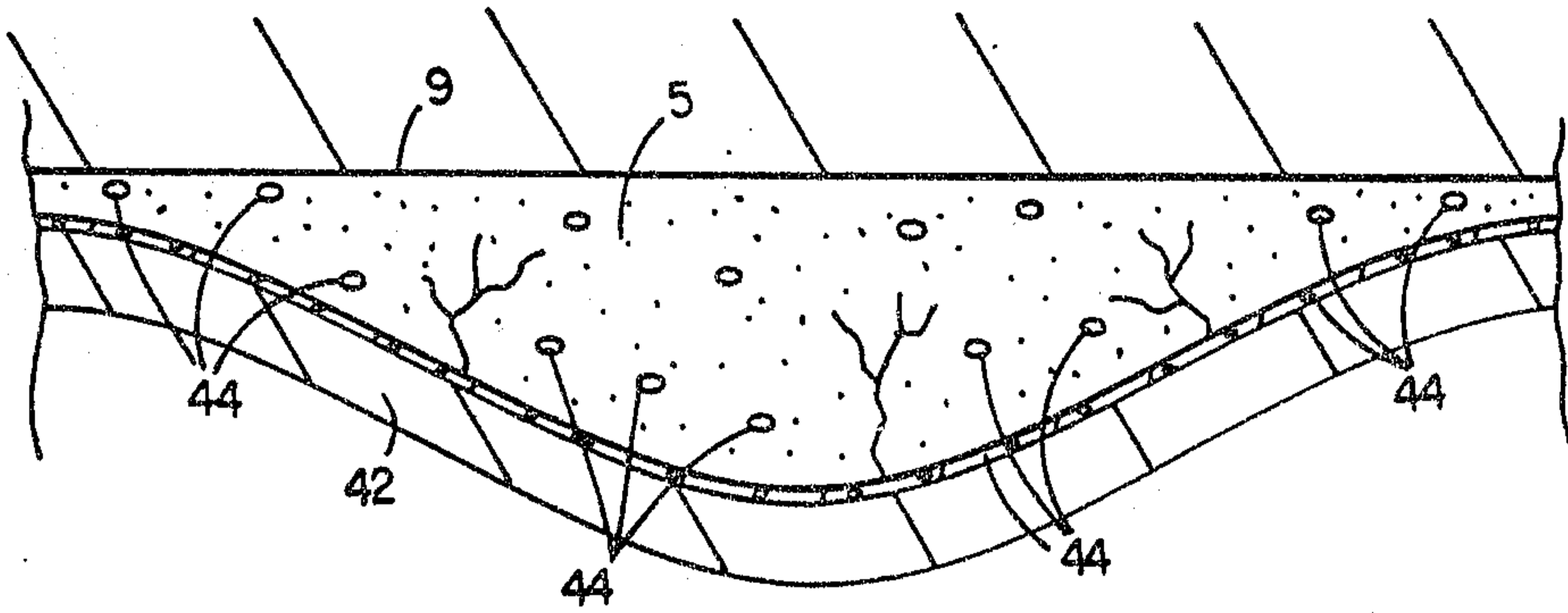

FIG. 3a

4/4

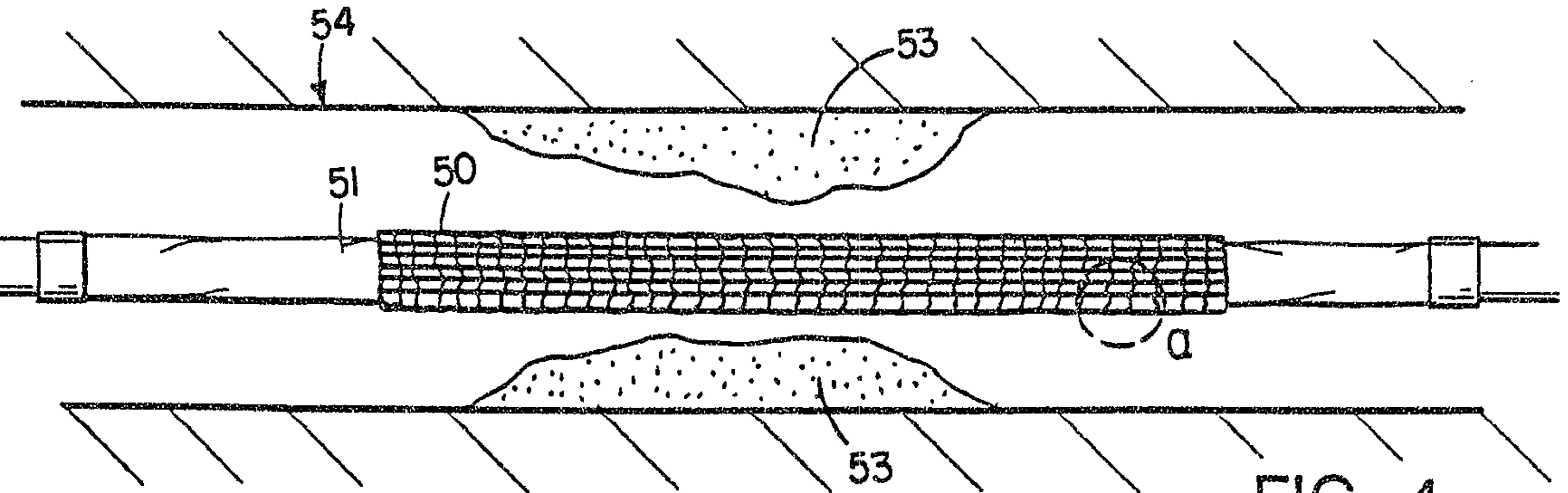

FIG. 4

FIG. 4a

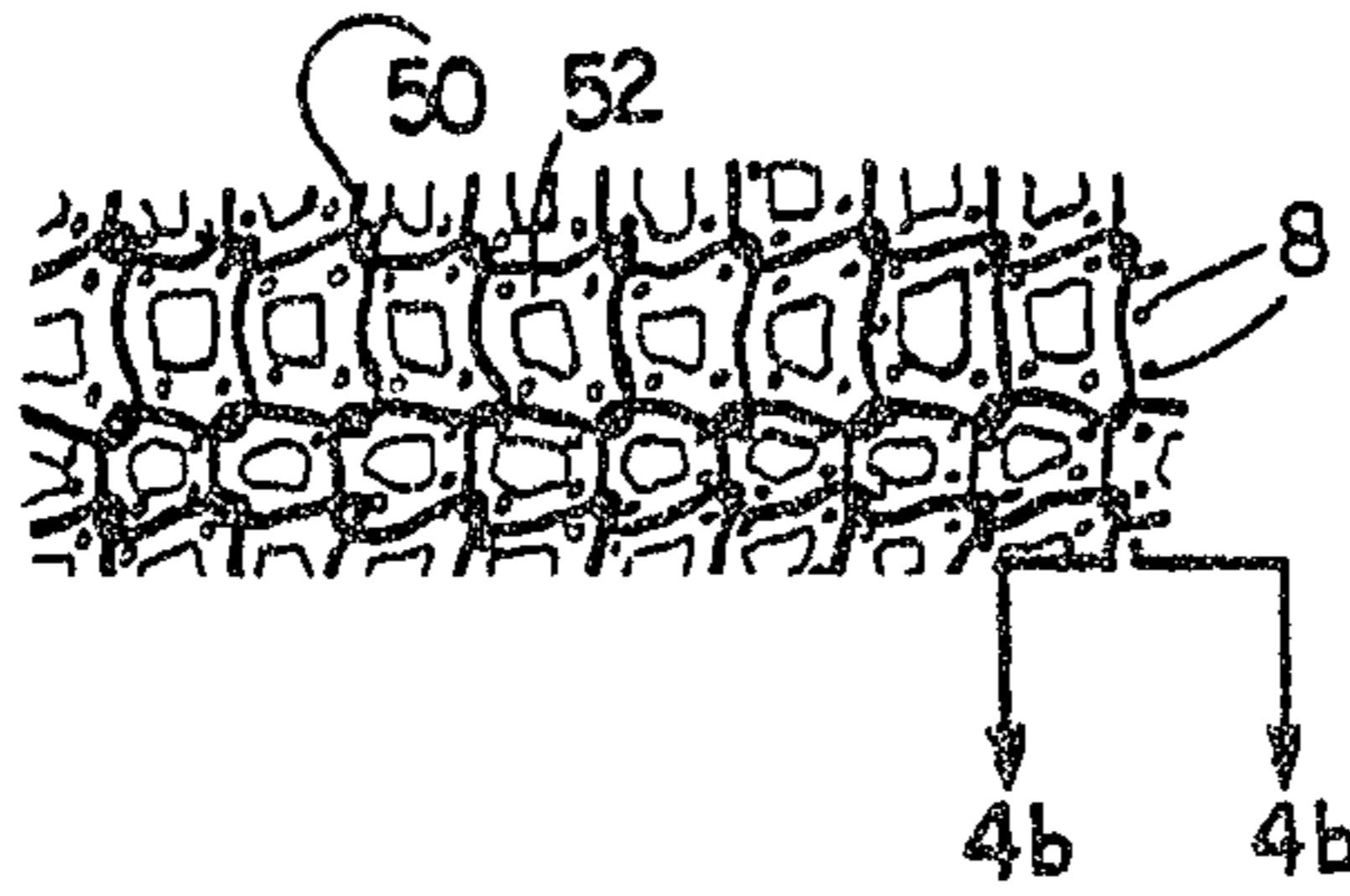

FIG. 4b

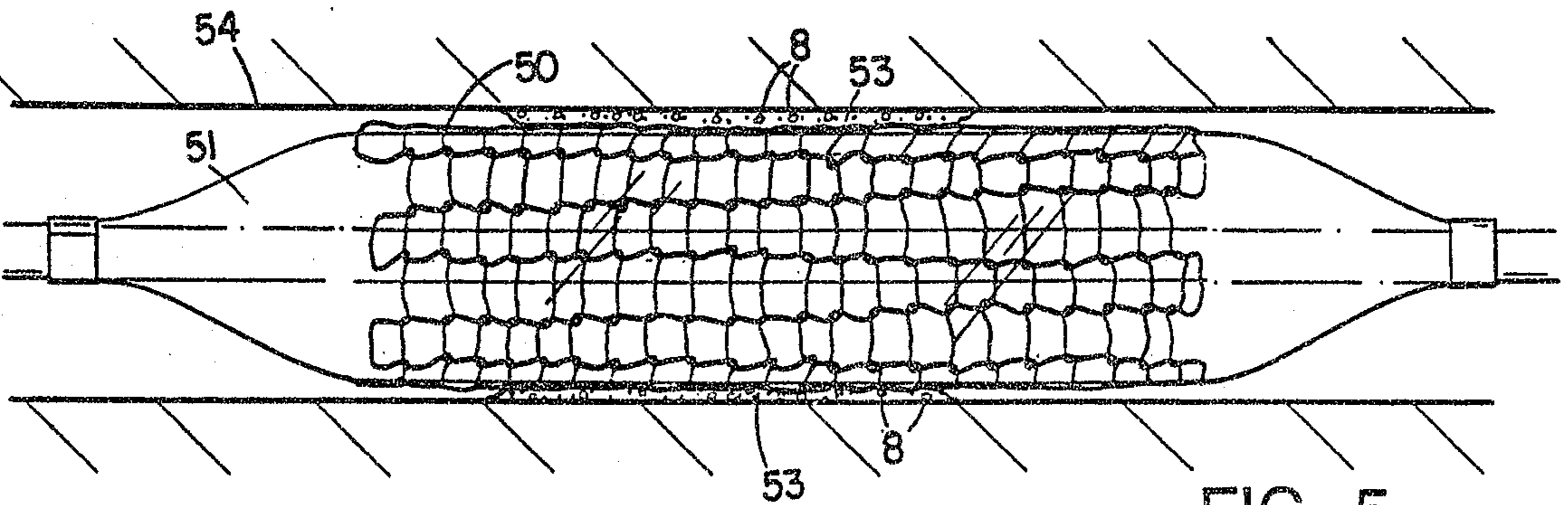

FIG. 5

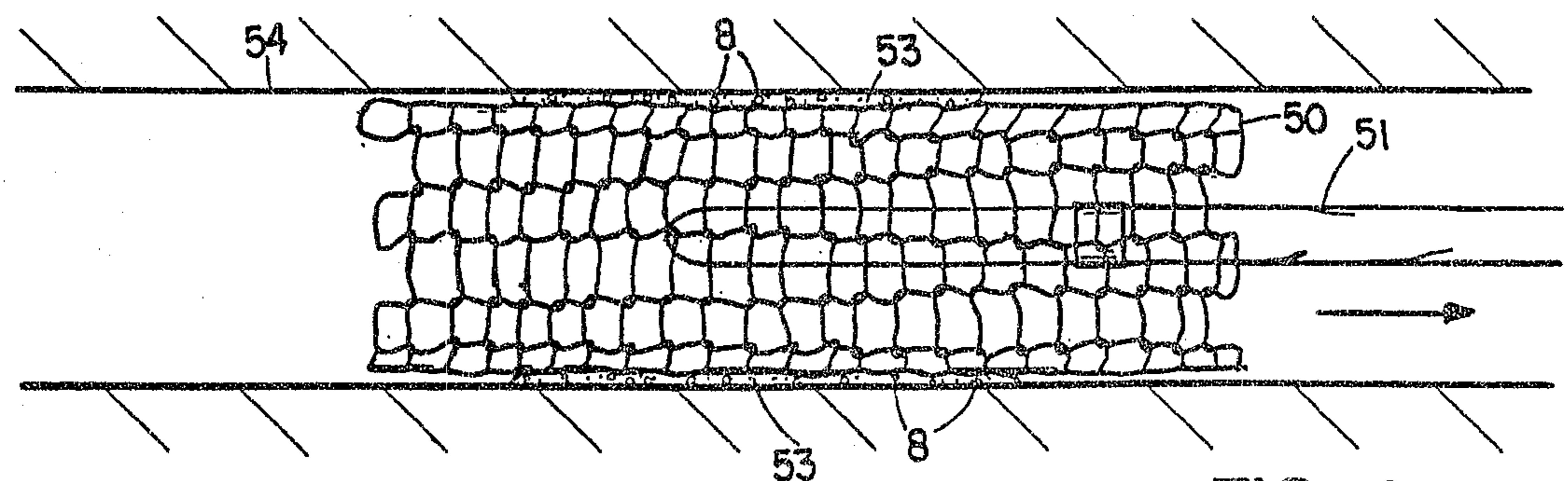

FIG. 6

